

Cryogenic safety of the superconducting ALPI accelerator at INFN-LNL



Ruggero Pengo, INFN-LNL

Outline of the presentation:

- Cryogenic Facilities at INFN-LNL (accelerators and Laboratories)
- Inventory of cryogenic fluids
- Safety criteria :
 - Materials and construction techniques
 - Protection for personnel and equipments
 - Most credible incidents related to cryo fluid discharge
 - Pressure relief valves, forced flow extractors, security plan,...

Cryogenic safety of the superconducting ALPI accelerator at INFN-LNL

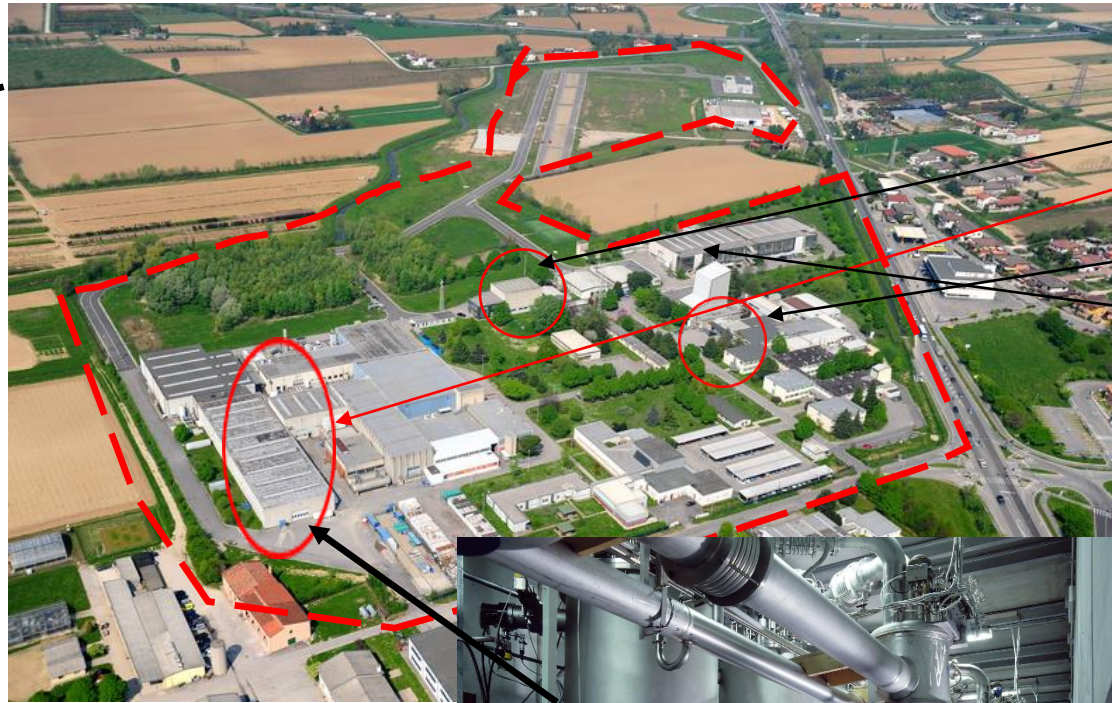

- Cryogenic installations @LNL:
- Gravitational Antenna
 - SC Linear Accelerator
 - Superconductivity Labs
 - Search for Axions



Cryogenic safety of the superconducting ALPI accelerator at INFN-LNL

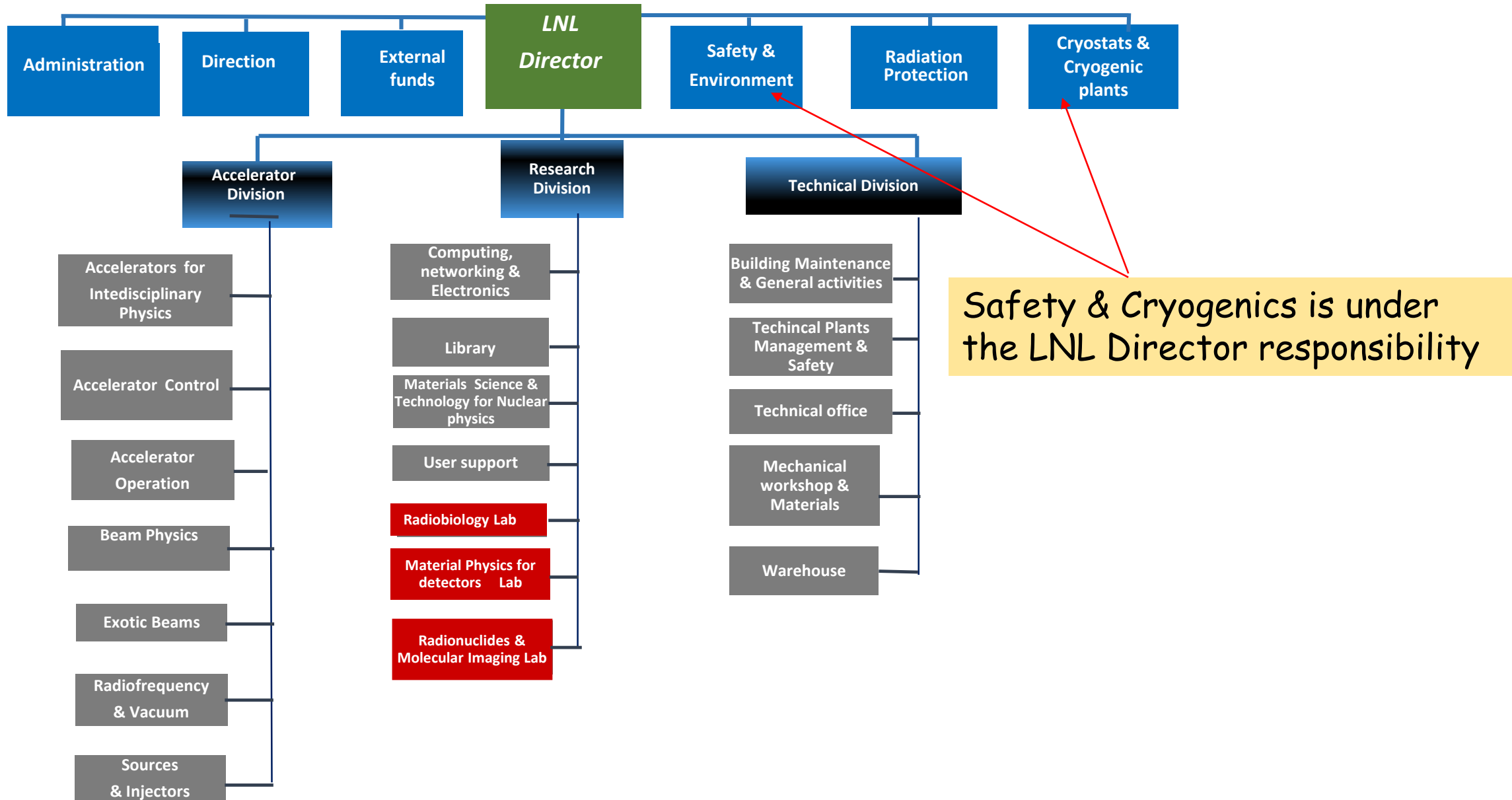

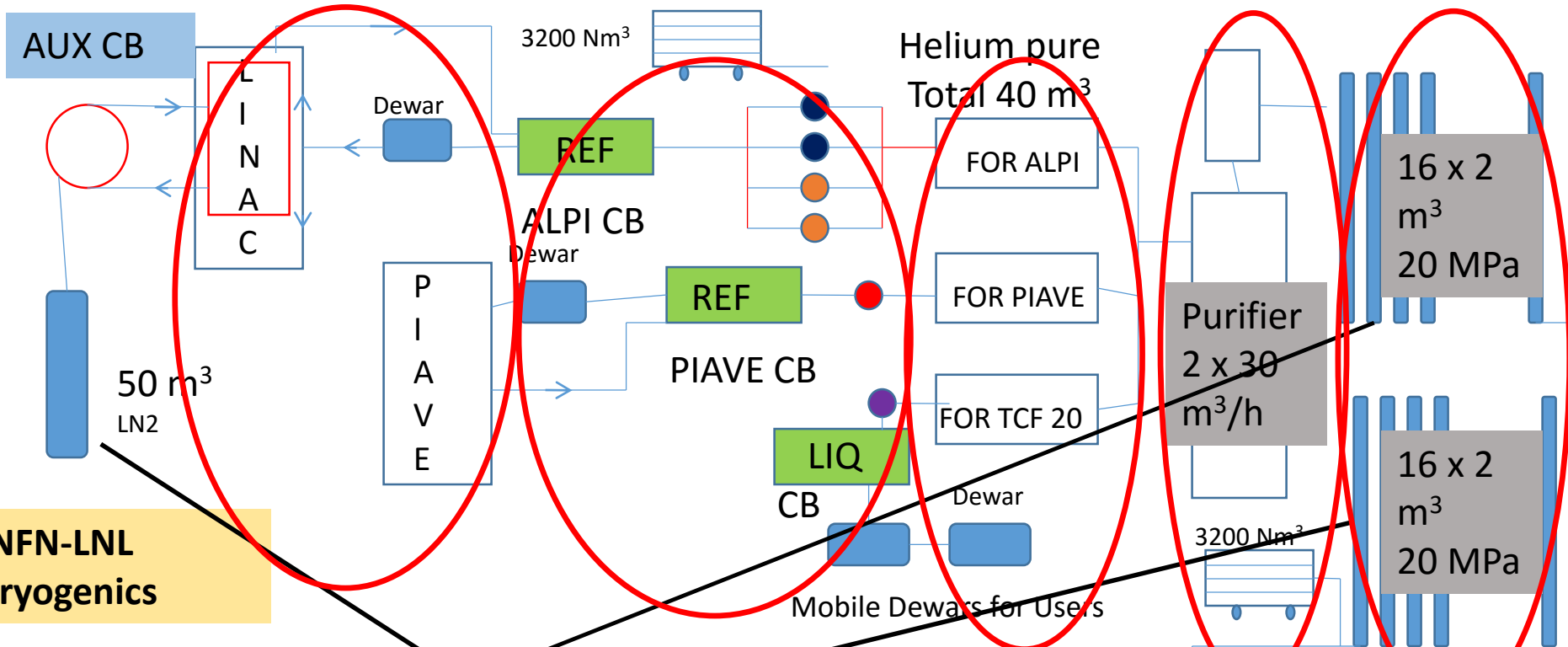

INFN-LNL Cryogenics

LNL TOTAL INVENTORY OF HELIUM IS 2.5 TONS

- CYCLE COMPRESSORS:**
- 65 g/s MYCOM
 - 96 g/s MYCOM
 - 2 x 55 g/s HOWDEN
 - 63 g/s KAESER
 - 33 g/s KAESER

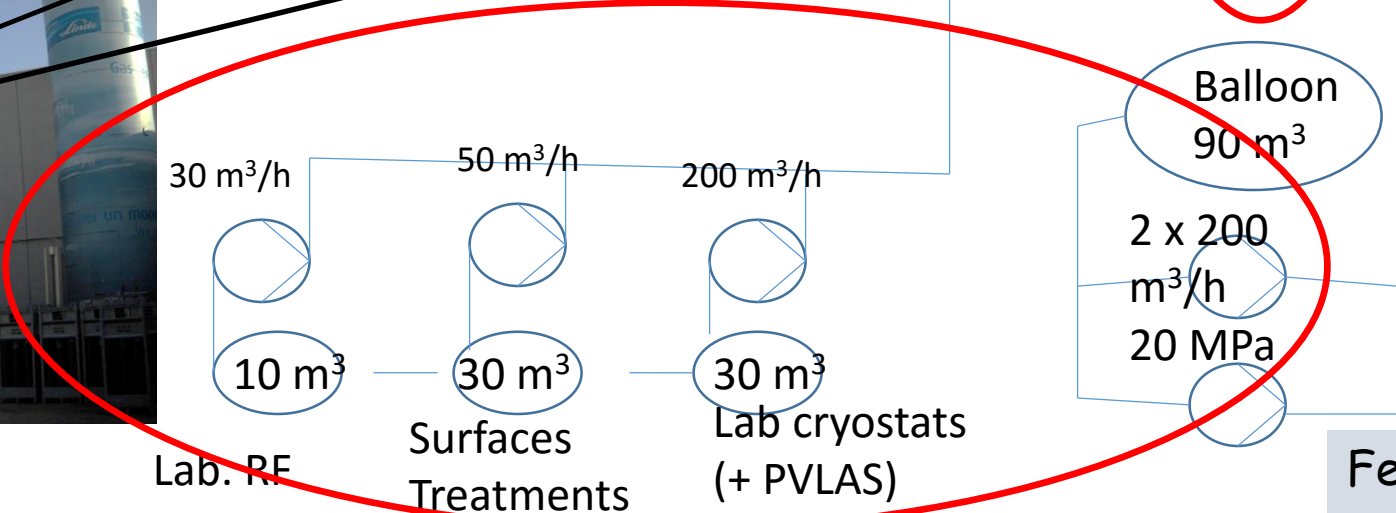

Few hundreds of meters of SS pipes

Cryogenic safety of the superconducting ALPI accelerator at INFN-LNL

- Refrigerators/liquefier at LNL:
 - Airlíquide ALPI Refrigerator
 - Linde TCF 50
 - Linde TCF 20



1200 W @ 4.5 K & 4000 W at 60-80 K,
CP 155 g/s

TCF50: 400 W @ 4.4 K, CP 63 g/s



TCF20: 20 (40) liter/h, CP 33 g/s



Keeping the thermal shields of CR cold, saves time in RF conditioning

Auxiliary CB															
Numbr	Temp	pressure	mass flow	DP	density	efficiency	P	P el	hours	cost	Temp out	Ref power	LN2	cost LN2	at 0.15 E/l
	K	bar	kg/s	bar	kg/m3		W	W	hours	Euro	K	W	l/h	Euro/day	Euro/month
2	80	6	0.1	0.5	3.57	0.6	1399.64	2332.735	1000	699.8205	90	10415	234	844	25308

One month cycle compressor	
kW	Euro
350	37800

@ LNL: 1 l/h LN2 ~ 1 kW.h
Aux CB is more convenient

Pure Gas Helium at 6 bar in a LN2 bath coil Heat Exchanger

Two Barber&Nichols GHe circulators, 100 g/s in series

The AUXILIARY COLD BOX

- is connected to the thermal shield GHe helium circuit of the cryostats
- is located in the accelerator building
- it is connected to a 50,000 Liters LN2 Dewar located outside the building

Save RF conditioning time but also increase the risk of LN2 spilling in the building

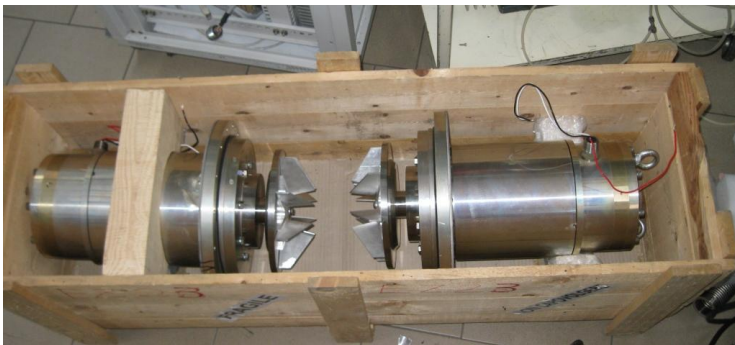

Cryogenic safety of the superconducting ALPI accelerator at INFN-LNL

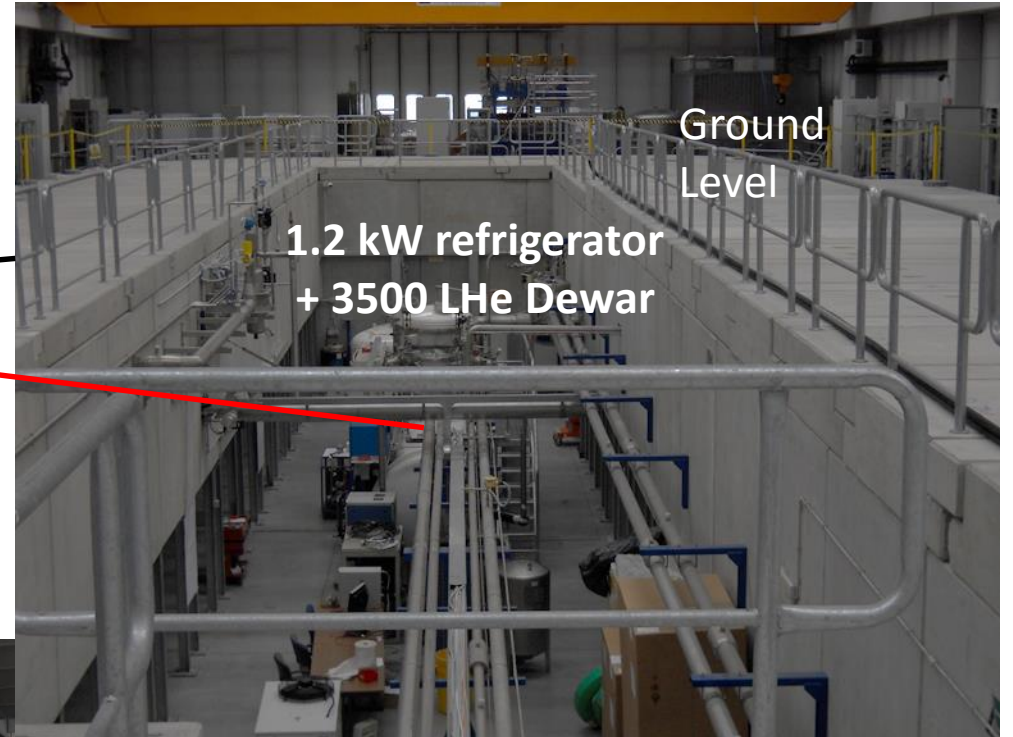
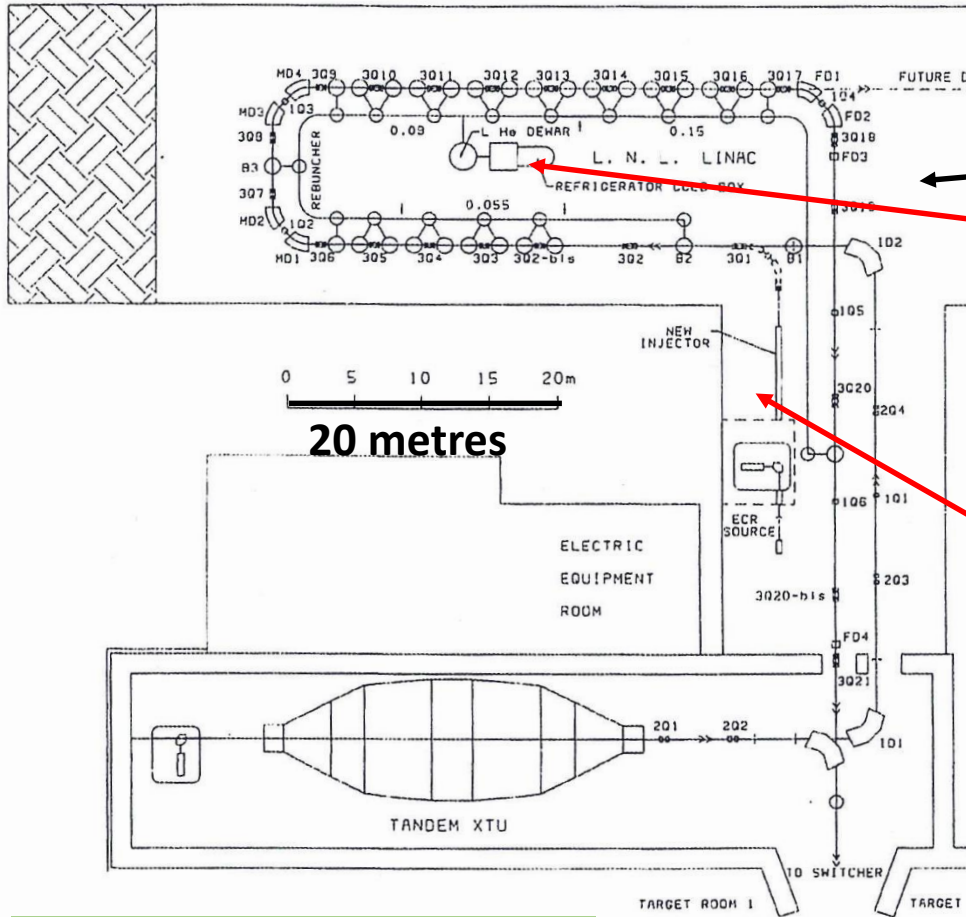

Ground Level

1.2 kW refrigerator + 3500 LHe Dewar



TCF50 + 3500 LHe Dewar

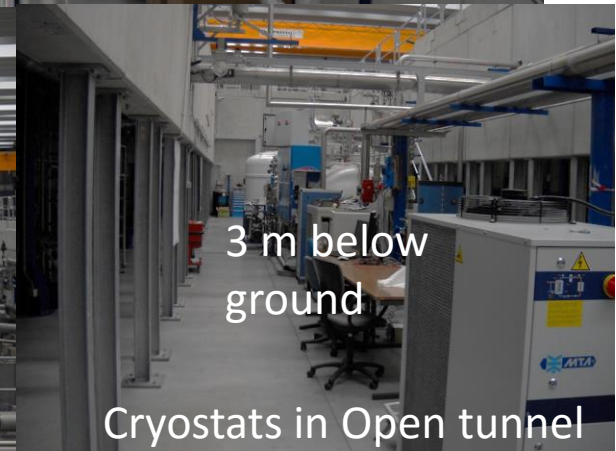

3 m below ground

Cryostats in Open tunnel

TOTAL VOLUME OF THE BUILDING (EMPTY) IS 26,000 m³

Cryogenic safety of the superconducting ALPI accelerator at INFN-LNL



ALPI LINEAR ACCELERATOR:
20 cryostats (all equal) for 74 RF
cavities:

- 3 buncher cryostats for 6 Nb/Cu QWR
- 13 cryostats for 52 Nb/Cu QWR
- 4 cryostat for 16 bulk Nb QWR

**TOTAL MAXIMUM LHE
CONTENT IS 20 X 100 = 2000
LITER**

- Double wall GHe thermal shield.
- Vacuum insulation is the beam vacuum: no MLI permitted (one foil)

Cryogenic safety of the superconducting ALPI accelerator at INFN-LNL

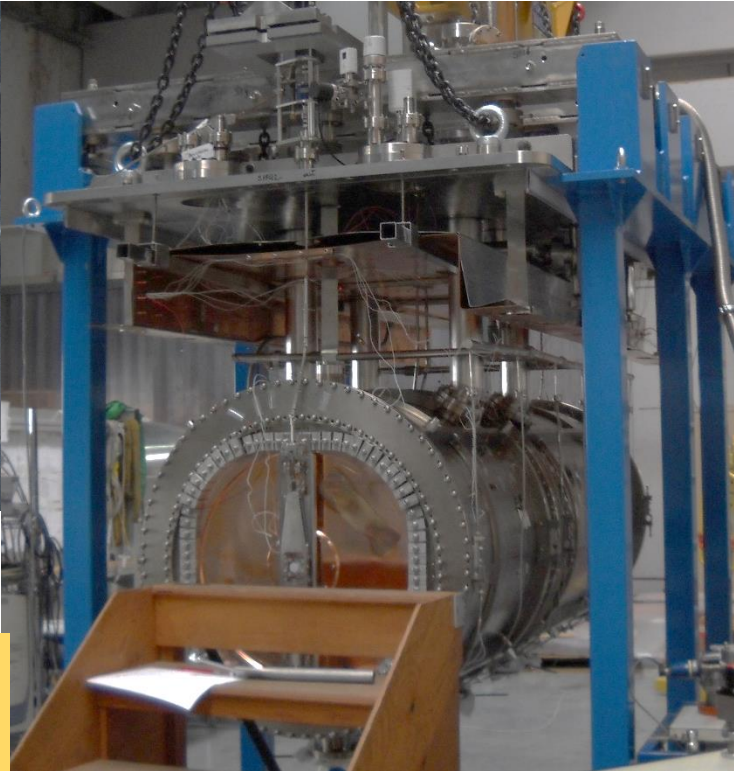

PIAVE Injector to ALPI
Linac:

- 2 Nb Bulk SRFQ in LHe Bath reservoir connected to TCF50
- LN2 thermal shield

TOTAL MAXIMUM LHE
CONTENT IS 200 LHe LITER
& 500 Liters LN2

Cryogenic safety of the superconducting ALPI accelerator at INFN-LNL



LHe Dewar max volume is 3500 liters

TOTAL INVENTORY OF LHE IN ALPI ACCELERATOR BUILDING:

- 2000 LITERS IN THE OPEN TUNNEL CRYOSTATS
- 200 LITERS IN PIAVE INJECTOR CRYOSTAT
- 2 x 2500 LITERS IN THE 3500 L DEWARS/PHASE SEPARATORS

TOTAL INVENTORY OF LN2 IN ALPI ACCELERATOR BUILDING:

- 500 LITERS IN THE THERMAL SHIELD OF PIAVE INJECTOR
- 1500 LITERS IN THE BACK-UP COLD BOX WITH GHE CIRCULATORS

EMPTY VOLUME OF THE BUILDING IS 26,000 m³



1500 liters LN2

Cryogenic safety of the superconducting ALPI accelerator at INFN-LNL

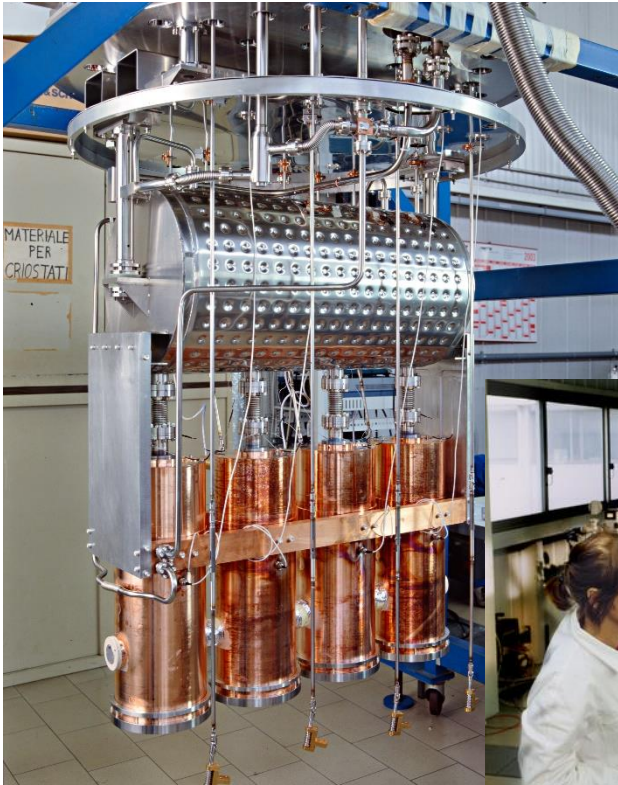

- Thermal conductivity «through the Cu-Cu brazing» was qualified
- Thermal shock at LN2 temperature (Cu-SS)



All SS components inside the cryostat are in 316L

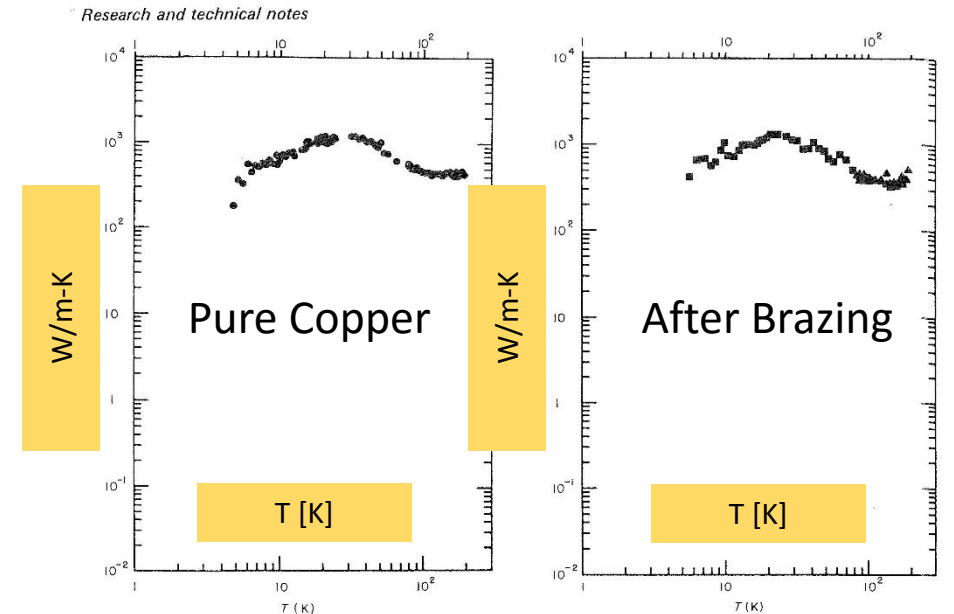

Figure 4 Data collected using SE-Cu sample

Figure 5 Data collected using sample with brazed joint: ■, LHe data; ▲, LN₂ data

R.Pengo et al. , Cryogenics **30** (1990) 74



Sputtered Nb

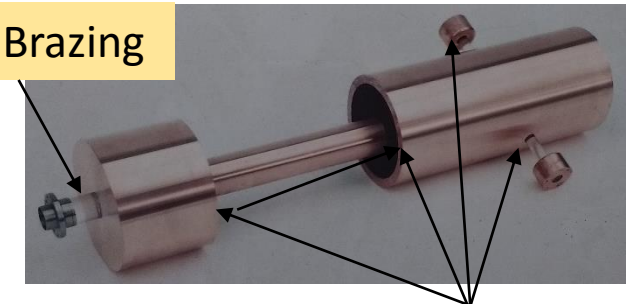

Cu-SS Brazing

Cu-Cu Brazing

Pressure Relief Valves dimensioning (1)

Dimensioning is carried out following the EN 13648-3, EN 4126-1 directives (certified by an external company) and approved by LNL, taking into account that:

- All cryogenic transfer lines, both for Helium and Nitrogen, are in SS and are vacuum insulated (no foam is used)
- In the different scenarios the centering bellows are considered the weakest part (no braded bellows are allowed in the cryostats)

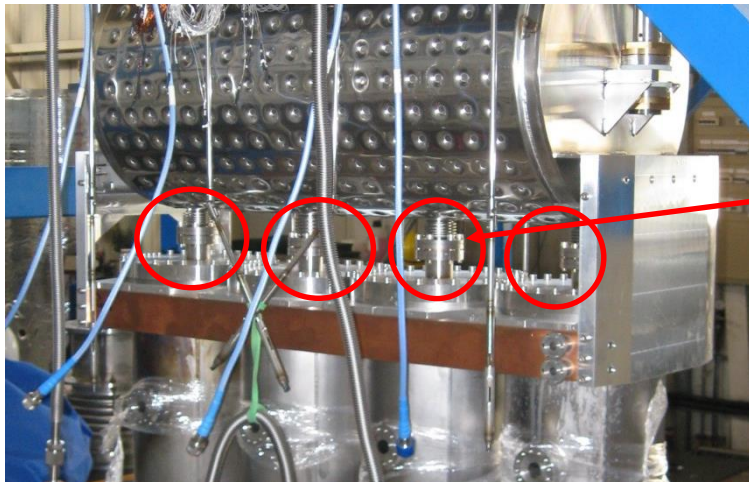

Centering bellows

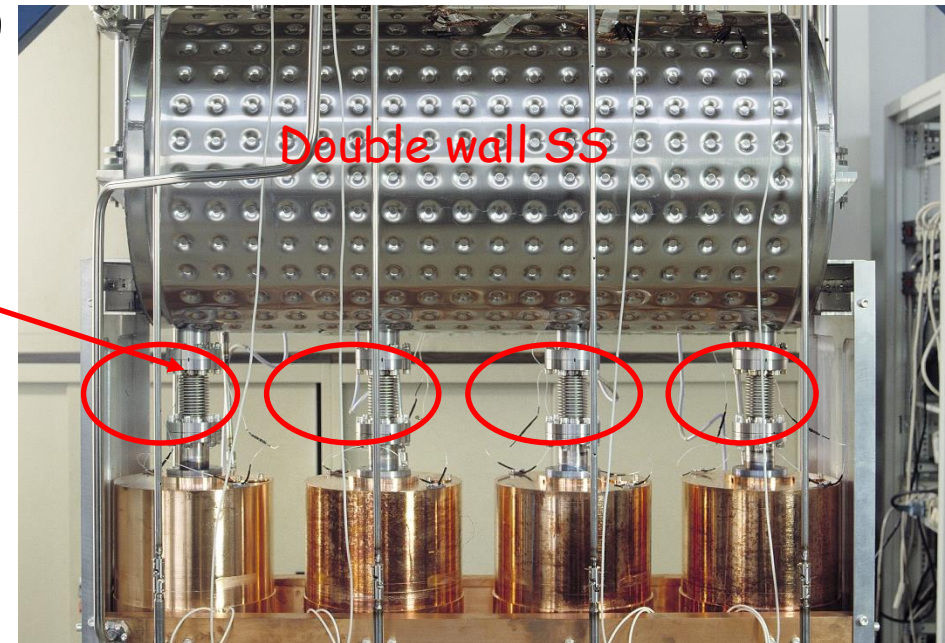

Double wall SS

Pressure Relief Valves dimensioning (1)

Dimensioning is carried out following the EN 13648-3, EN 4126-1 directives (certified by an external company) and approved by LNL, taking into account that:

- There is no MLI, then 38 kW/m² heat load is considered in case on vacuum rupture
- Fire (heat load 70 kW/m²) is not considered as a likely accident
- EM stored energy in the sc cavities is negligible (no quench case as for sc magnets)
- All Pressure Relief Valves discharge in the accelerator building (there are no collecting ducts, no additional pressure drop)
- Opening values for the PRV's for the Nb bulk cavities must be as low as 0.5 barg (1.2 barg for the Cu/Nb).
- Thermal shields operate around 6 bara and PRV's open at 9 bara
- (As an additional safety the top flange is left without nuts: 1 m² for about 10 tons of weight, so a minimum overpressure will lift the top flange discharging the GHe)

Pressure Relief Valves dimensioning (2)

Opening values for the PRV's for the Nb bulk cavities must be as low as 0.5 barg (1.2 barg for the Cu/Nb). Thermal shields operate at 6 bar and PRV's open at 9 bar

Useful tools for the dimensioning of the PRV's are:

- **Edeskuty**, from «Safety in the Handling of Cryogenic Fluids», F.J. Edeskuty and W.F. Stewart, Plenum press 1996
- **SV_Berechnung_E.xls**, Excel file (G.Perinic, CERN) available from Perinic website http://gperinic.web.cern.ch/gperinic/DEFAULT_old.htm (HEPAK)
- **Kryolize**, Excel file (A.Henriques, CERN) available from andre.henriques@cern.ch and/or Technology Transfer Office Technology.Transfer@cern.ch
- **Technology of Liquid Helium**, National Bureau of Standard, 1968

"Most credible incident in terms of cryogenic fluid's discharge that could happen in accelerator tunnels during maintenance phases":

- Opening of the Cryostats (one or more) PRV in the open tunnel
 - The feeding LHe line is closed (NC)
 - The Low pressure return GHe remains open (NO)
 - The Refrigerator might be automatically cut off (depending on the LP)
- Spilling of LN2 in the building
 - Overflow from Auxiliary Cold Box, rupture of cryo connections,...
 - It is detected by the OD detectors in the building
- Rupture of LHe Dewars (e.g. wrong crane operation, very unlikely)
 - It is detected by the OD detectors in the building

Cryogenic safety of the superconducting ALPI accelerator at INFN-LNL

FOUR ODH DETECTORS ARE PLACED IN THE OPEN TUNNEL JUST ABOVE THE HOLES ON THE CONCRETE WHERE THE PASSERELLE IS. THEY TRIGGER:

- THE EVACUATION ALARM
- START THE EXPELLER FANS
- CLOSE THE OUTDOOR VALVES TO THE LN2 DEWAR

Personnel of the cryo group is ON CALL duty 7/7 days & 24H (called by the security guards)

Honeywell | Analytics | Solutions | Industries | Applications | Products

Home > Products > Signalpoint Flammable and Toxic Gas Detector

Industrial Flame and Gas Systems

Signalpoint Flammable and Toxic Gas Detector

The Signalpoint range of flammable, toxic and Oxygen gas detectors offers a low cost solution to indoor gas monitoring.

Features & Benefits

- Flammable, toxic and Oxygen versions available
- ATEX hazardous area approval
- Wall or ceiling mounting

Quick Specs

- Sensor: Polyphenylene Sulphide (PPS), Integral



ACCESS PASSERELLE

Four more ODH detectors are placed at 50 cm from the floor close to the LN2 Containers

Cryogenic safety of the superconducting ALPI accelerator at INFN-LNL

FAN EXTRACTORS OUTSIDE
THE OPEN TUNNEL
-3 IN THE UPPER LEVEL AND
ONE ON THE LOWER LEVEL

THE FLOOR IS ABOUT 3 METER
BELOW GROUND

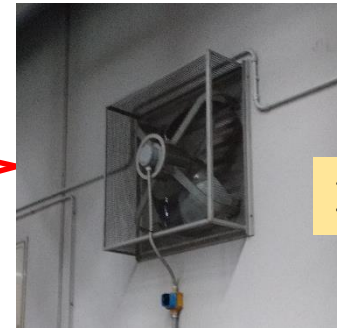

15 000 m³/hour

EMERGENCY EXITS AT
THE GROUND LEVEL

THERE ARE ALSO ELECTRIC
WINDOWS ON THE CEILING
(MANUALLY ACTIVATED)

FAN COILS FOR
HEATING/AIR CONDITIONG
SYSTEM ARE CIRCULATING
AIR FROM OUTSIDE

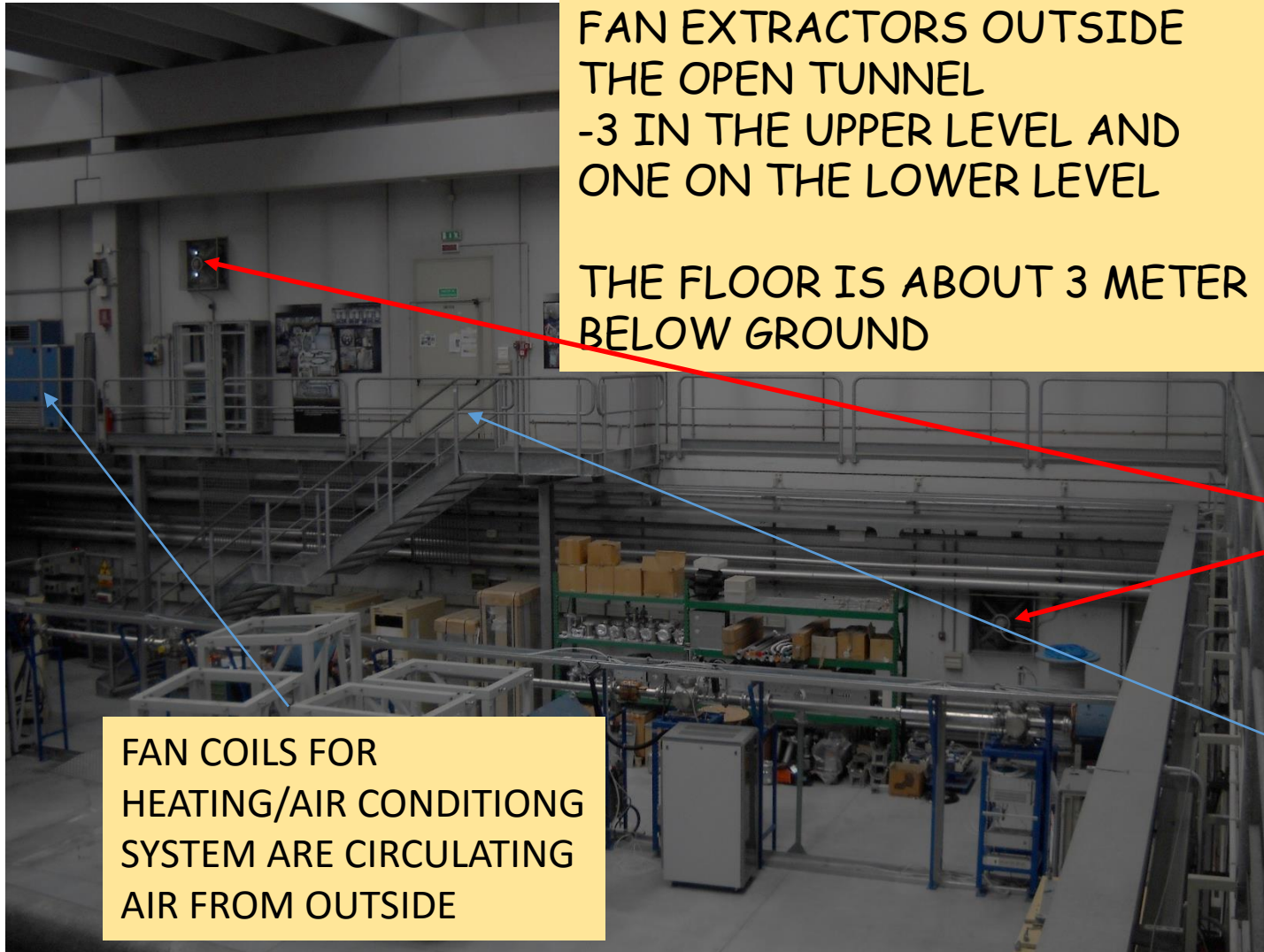

Cryogenic safety of the superconducting ALPI accelerator at INFN-LNL

THE OPEN TUNNEL IS NOT SEALED AT THE TOP



- **THERE ARE HOLES ON THE CONCRETE SLABS (EACH 10 CM DIAMETER)**
- **FOUR FAN EXTRACTORS WILL BE ADDED TO SPEED UP THE RELEASE OF GAS HELIUM AT THE TOP OF THE OPEN-TUNNEL (2000 M3/H)**
- **SAFETY AIR MASK WILL BE MADE AVAILABLE AT BOTH ENDS OF THE PASSERELLE (ACQUIRED BUT NOT YET POSITIONED)**

Cryogenic safety of the superconducting ALPI accelerator at INFN-LNL

http://www.draeger.com/sites/en_uk/Pages/Chemical-Industry/Draeger-Saver-CF.aspx



- SAFETY AIR MASK CHOSEN BY THE SAFETY SERVICE
- TO BE PLACED AT BOTH ENDS OF THE PASSERELLE IN THE OPEN TUNNEL



 Draeger. Technology for Life®

ACCESS POLICY TO THE ALPI ACCELERATOR BUILDING

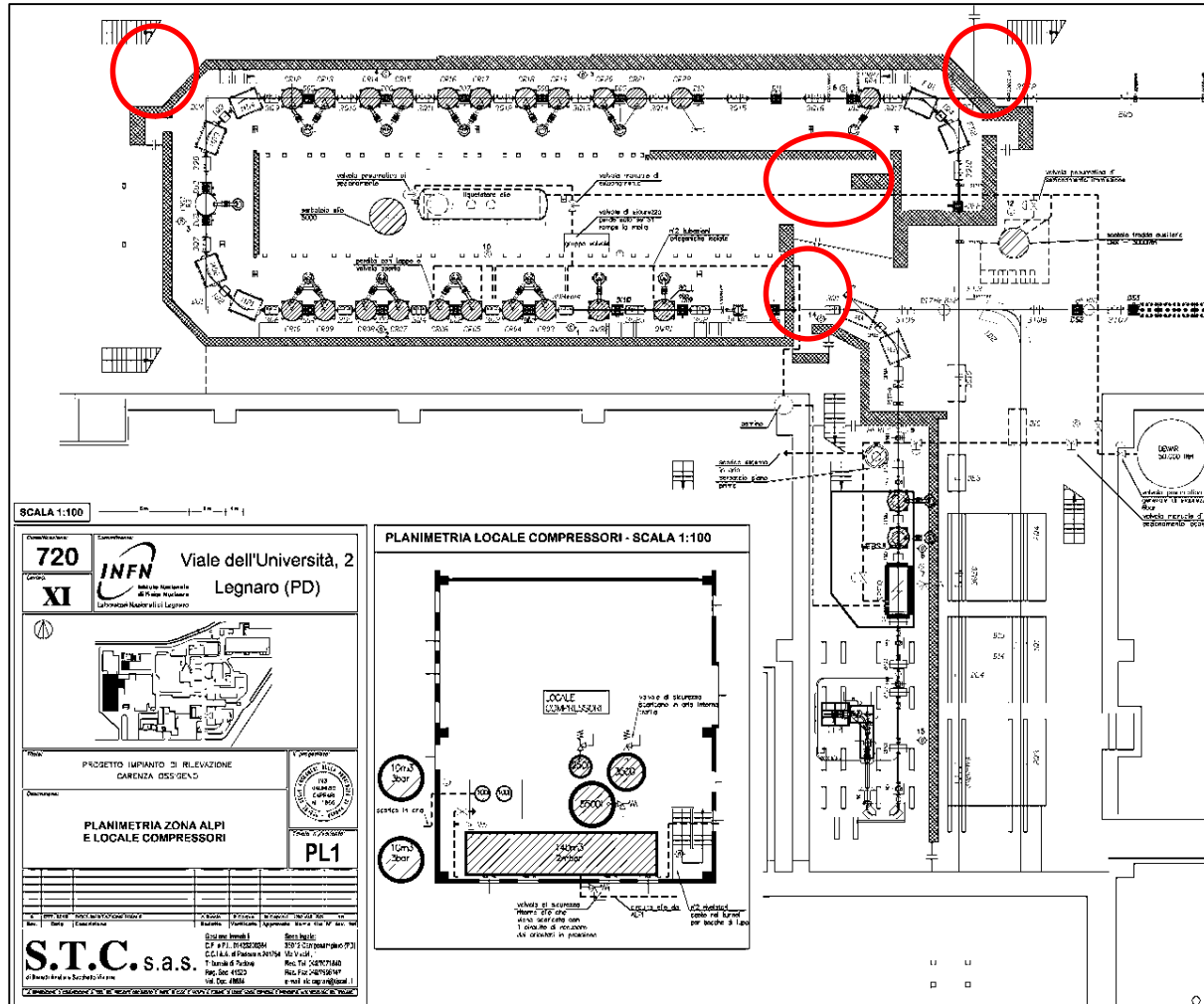

Lower Level:

There are access gates to the open tunnel with interlocks:

- No access with RF ON (with and without the beam)
- No access during RF conditioning of the cavities
- Limited access (e.g. for maintenance) when LHe and/or LN2 in the cryostats. Machine operators give permission. Then:
- «fare la ronda» the gates must be physically acknowledged with a definite sequence

Cryogenic safety of the superconducting ALPI accelerator at INFN-LNL

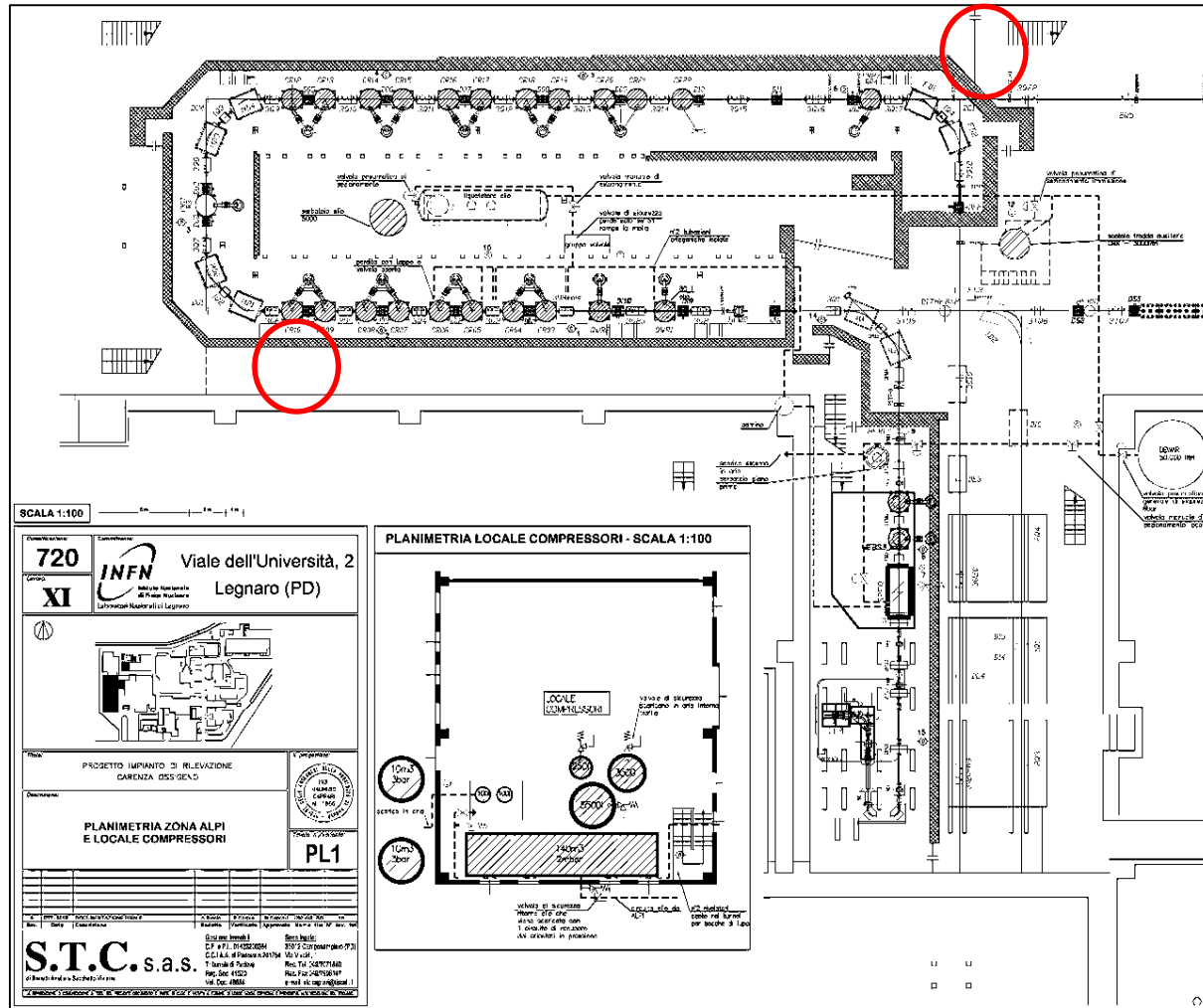

Upper Level:

No access also on the upper level (i.e. ground level) when the beam is ON and during RF conditioning. Access is permitted when cryostats are cold

Cryogenic safety of the superconducting ALPI accelerator at INFN-LNL

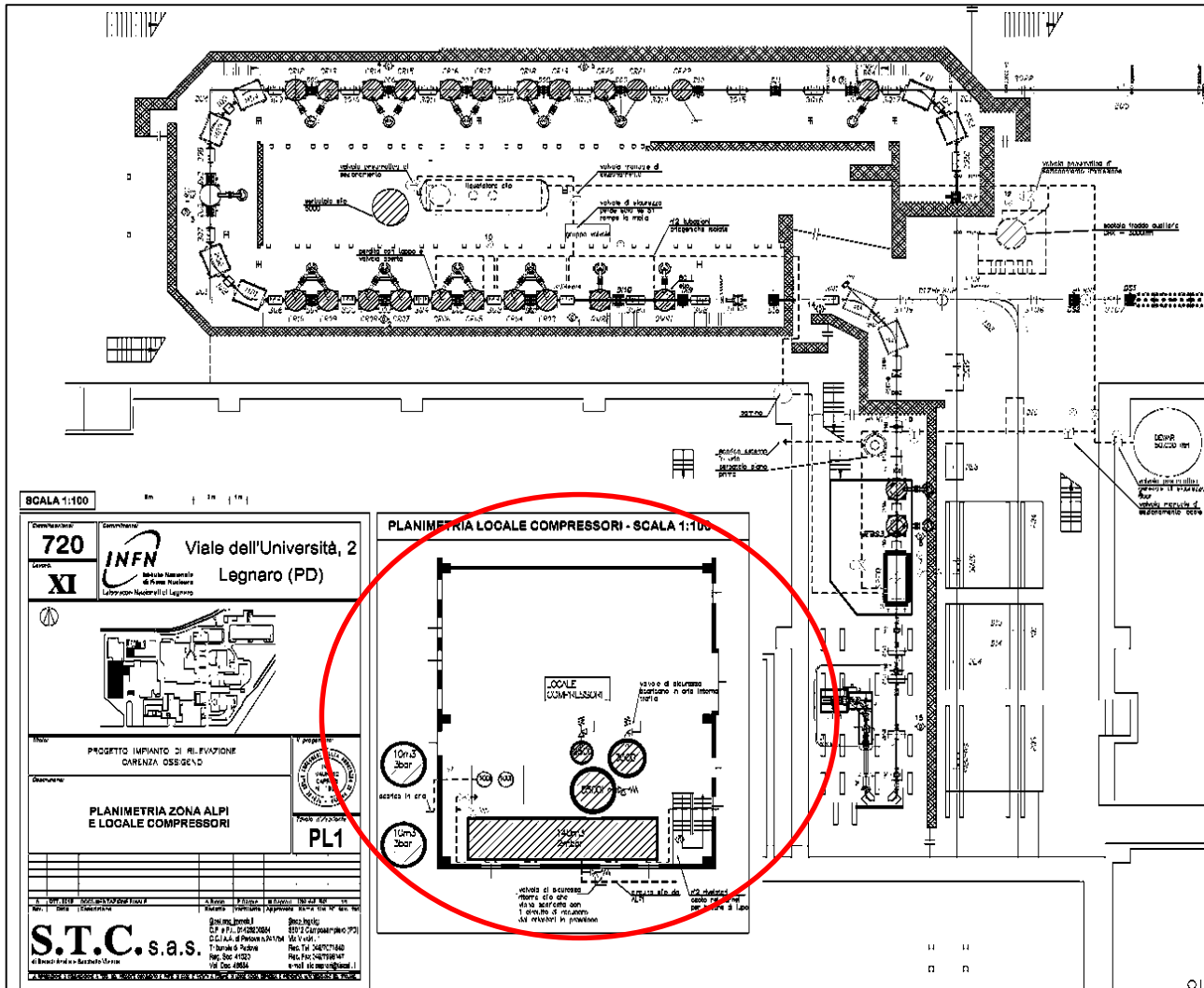

In the cycle compressor building are installed :

- TCF20 liquefier with its KAESER cycle compressor
- 5000 L LHe Dewar connected to TCF20
- 3500 L LHe mobile Dewar (Gravitational antenna)
- 2x 200 m³/h high pressure (200 bar) recovery compressor

The building is connected to the ALPI building by means of an underground tunnel with a grid gate.

Two ODH connected to two extractor fans (floor & ceiling).

Access to the building allowed to the Cryogenic group personnel with a card code.

Conclusions

- The superconducting accelerator is operational since early 90's and no accidents have happened so far.
- Cryogenics at LNL is undergoing a major upgrade/refurbishing (3rd sc turbine, UNICOS-CERN cryo-control system, safety review and its consolidation.)
- All interventions, for the institute policy/necessity, cannot be carried out (unfortunately) through a "Long Shut Down", but has to be implemented during the short "no users" periods (a few months a year)
-it takes a little longer.

Thank you for your attention

Cryogenic safety of the superconducting ALPI accelerator at INFN-LNL

Cryogenic safety of the superconducting ALPI accelerator at INFN-LNL

Cryogenic safety of the superconducting ALPI accelerator at INFN-LNL