



ROOM TEMPERATURE MAGNETS - ANALYTICAL DESIGN EXERCISE

J. Bauche, A. Milanese, J Borburgh, P. Thonet
CERN

CERN Accelerator School, Normal and Superconducting Magnets
St. Pölten, Austria, November 2023

- Guidelines for the analytical design
 - The analytical design of a normal conducting magnet is an iterative process where you need to make educated assumptions of several parameters, that you will confirm/modify as you progress with the calculations.
 - We strongly advise that you perform your calculations on an Excel (or equivalent) spreadsheet or any other software which allows you to modify/iterate the parameters. This spreadsheet will be your tool for your future magnet designs!
 - Think of adding some margin to the initial specification, as to limit the sensitivity of your design to the variability of some parameters (e.g. iron BH curve, geometrical tolerances, etc.).

- The beam optics physicists are designing new beam lines for the energy upgrade of our RIB facility with this layout:

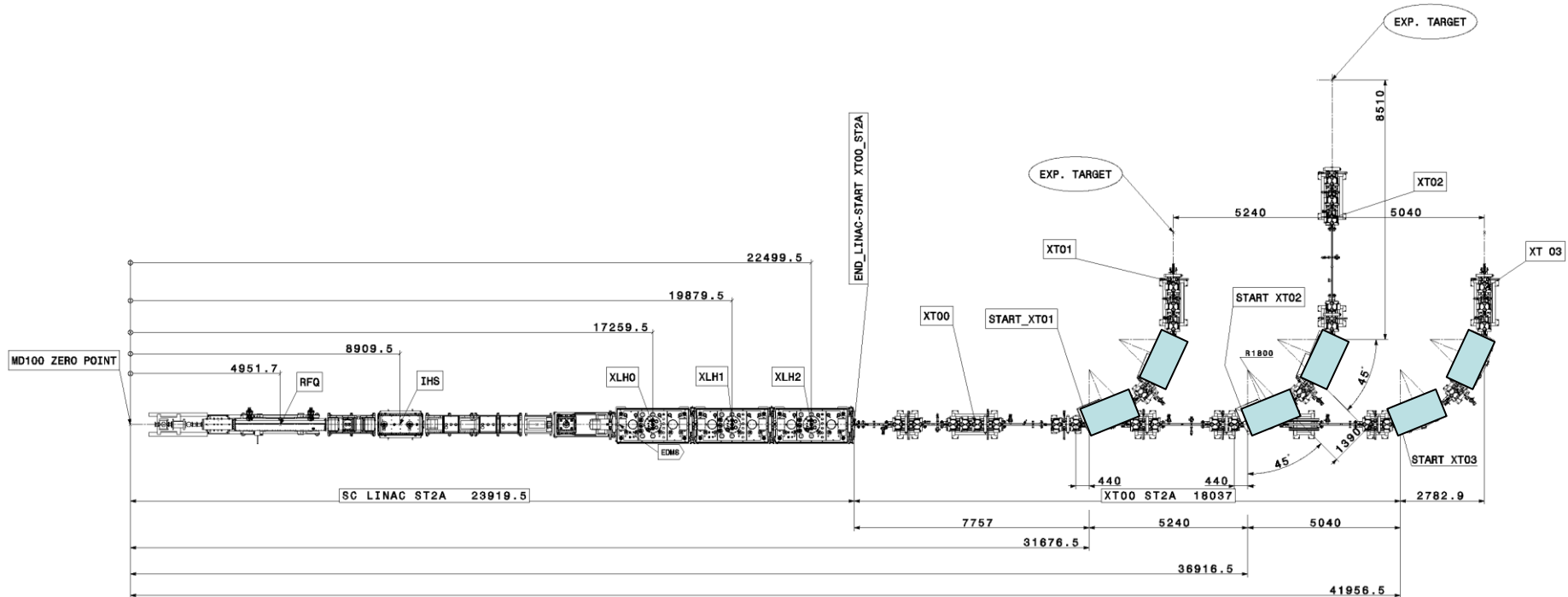

- We are asked to design a dipole magnet which can fit in the available spaces shown with the blue boxes.



Day 1 - exercise: functional specifications



- Three power converters [500 A, 120 V] are available, one for each beamline, as well as powering cabling with 240 mm² cross-section.
- Cooling water at 27°C is available at up to 10 bars of delta P from the network in the building, to which other magnets with copper conductors are already connected.
- A functional specification is provided which summarizes the requirements for the magnet design.

Parameter	Value	Unit
<i>Beam parameters</i>		
Particle type	Ions	
Mass-to-charge ratio range	2:1 to 4.5:1	
Kinetic energy range	3 to 10	MeV/u
<i>Layout parameters</i>		
Magnet topology	Dipole, R-bend	
Bending direction	Horizontal	
Number of magnets per transfer line (powered by same converter)	2	
Bending angle (per magnet)	45	deg
Available physical length along beam line (per magnet, straight)	1700	mm
<i>Magnetic parameters</i>		
Horizontal good field region (GFR-horiz)	± 30	mm
Vertical good field region (GFR-vert)	± 20	mm
Field quality inside GFR (max. field error $\Delta B/B$)	± 5.0E-04	
<i>Vacuum parameters</i>		
Vacuum chamber wall thickness	2	mm
Vacuum chamber insulation thickness	1	mm
Vacuum chamber assembly tolerance	±1.5	mm
<i>Cooling parameters</i>		
Max. water pressure differential available from network	10	bars
Inlet water temperature	27	°C
Cooling circuit compatibility	Copper conductors	
<i>Electrical parameters</i>		
Operation mode	DC	
Max. power converter current	500	A
Max. converter voltage (2 magnets in series)	120	V
Distance from converter to magnets	50	m
Cross-section of available copper powering cabling	240	mm ²

- Exercise 1: field strength

- Compute the maximum and minimum beam rigidities

$$B\rho = \frac{1}{c} \frac{A}{q} \sqrt{E_k^2 + 2E_k E_0}$$

- *Magnetic beam rigidity: $B\rho$ [T.m]*
- *Mass-to-charge ratio: A/q []*
- *Speed of light: $c = 299792458$ [m/s]*
- *Kinetic energy (per nucleon): E_k [eV]*
- *Rest mass energy of nucleon: $E_0 = 931.5 \times 10^6$ [eV]*

Hint: the magnet cross-section is defined by the maximum field strength. You need to add some margin to it, typically 10 to 15%.

- Compute the corresponding field strengths (integrated dipole field)

$$B \cdot L_{mag} = \theta \cdot B\rho$$

- *Integrated dipole field strength: $B \cdot L_{mag}$ [T.m]*
- *Bending angle: θ [radians]*

- Exercise 2: yoke design

- Based on the beam line layout, select the most appropriate yoke geometry (C-shape or H-shape). Justify your choice.
- Compute the maximum iron length of your magnet

Hint: you need to make an assumption on the space taken by the coil windings at the magnet extremities, that you will verify and iterate once you will design your coils

- Define the vertical aperture (air-gap between poles)
- Compute the magnetic length (straight trajectory along magnet axis)

Hint: an R-bend magnet can be straight or curved. In both cases, the effective magnetic length is the one seen by the beam, along its curved trajectory

- Compute the beam bending radius
- Compute the magnetic length (curved trajectory)
- Compute the maximum flux density (B field) in the aperture centre

- The magnet physical length includes the iron length and the coil returns at the extremities

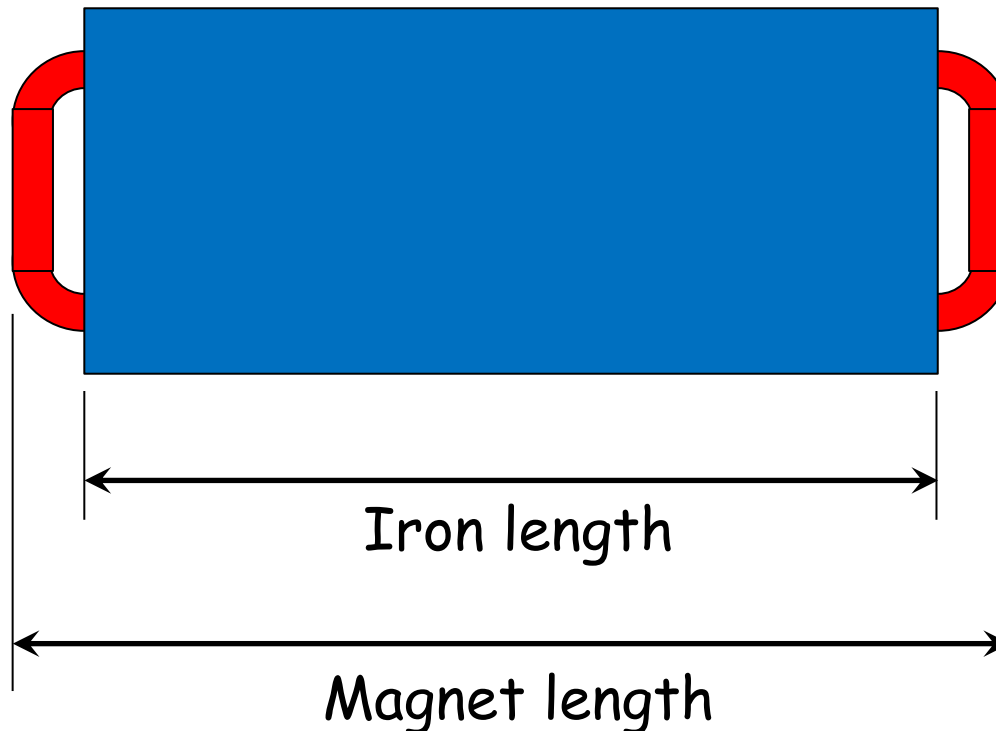

- Magnetic length estimated from the iron length and aperture

$$l_m \cong l_{Fe} + h$$

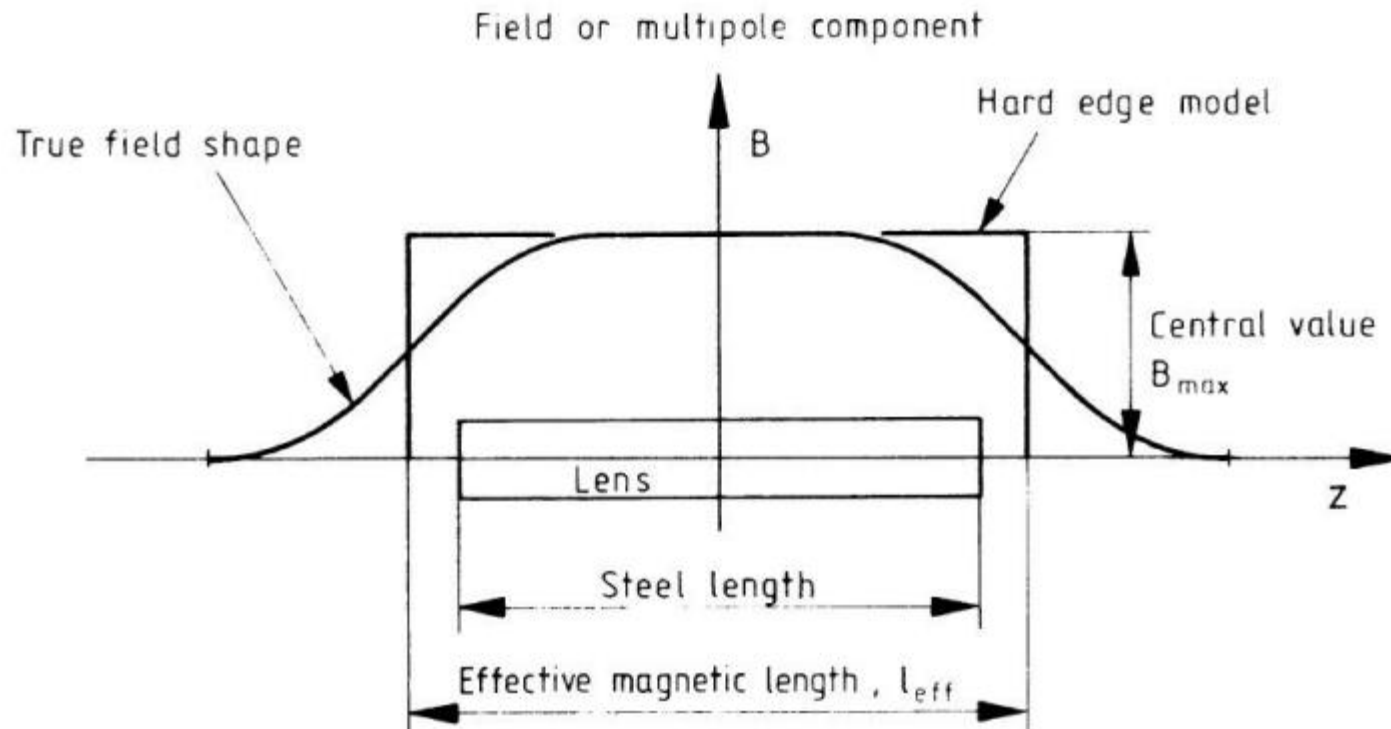

- Bending radius

$$\rho = \frac{L_{\text{mag straight}}}{2 \sin \frac{\theta}{2}}$$

- Magnetic length

$$L_{\text{mag curved}} = \theta \rho$$

- Sagitta

$$S = \rho \left(1 - \cos \frac{\theta}{2} \right)$$

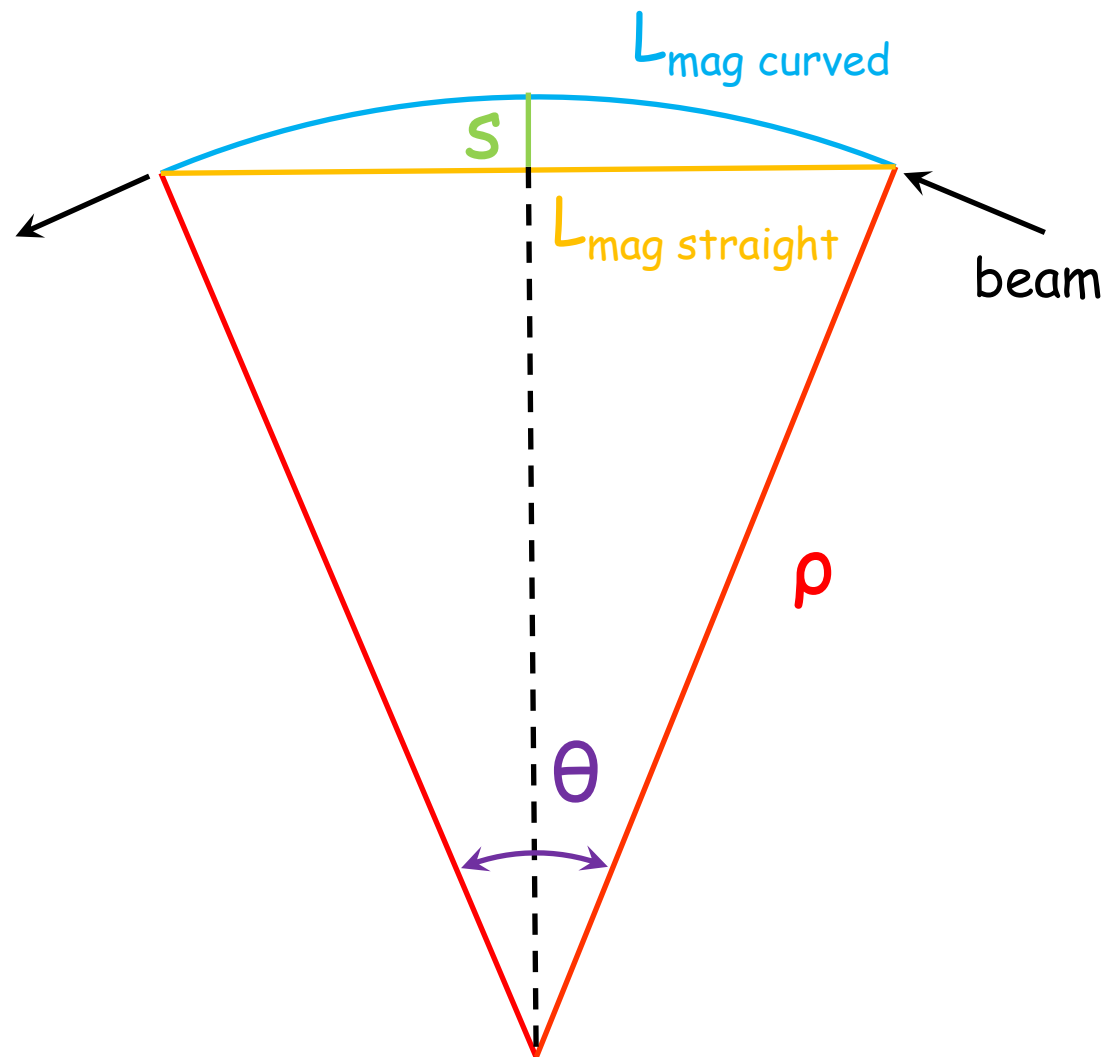

- Exercise 2: yoke design

- Compute the beam sagitta of the curved trajectory
- Compute the pole width for a curved magnet

Hint: several empirical formulas / experimental recipes exist to define the pole width based on the field quality. For this exercise, you can compute them all and chose the one you find the most appropriate. Keep in mind that a larger pole eases the field quality optimization, but increases the magnet size and cost

- Compute the pole width for a straight magnet (incl. beam sagitta)
- Choose between a curved or a straight magnet geometry
- Set the maximum flux density in the iron yoke back-leg

Hint: avoid operating the iron back-leg in saturation

- Compute the yoke back-leg width
- Compute the pole shim area for field optimization (Kashikhin)

- Exercise 3a: coil design – size and geometry

- Set the magnet efficiency

Hint: if you operate below iron saturation this is typically around 98-99%

- Compute the ampere-turns for the maximum field
- Set the maximum powering current

Hint: take a margin of at least 10% w.r.t. the power converter rating

- Compute the corresponding number of turns of the coil windings
- Define a winding architecture with a number of turns close to this calculation, that can be made with an even number of coils with a rectangular cross-section (e.g. 100 turns could be 2 coils of 5 layers with 10 turns per layer)

Hint: rectangular cross-sections with larger base than height work better for a C-shape horizontal dipole. Ideal aspect ratios are typically between 3:2 and 2:1

- Re-compute the maximum powering current and the margin to the power converter rating (iterate if necessary)

- Exercise 3a: coil design – size and geometry

- Set the maximum current density in the conductor active area (i.e. in copper)

Hint: typical (reasonable) current densities are up to ~ 1 A/mm² for air-cooled conductor, ~ 2 to 3 A/mm² for indirectly water-cooled conductor (with heat sink) and ~ 4 to 7 A/mm² for directly water-cooled conductor (hollow conductor)

- Compute the required conductor active area for that current density
- Select a suitable commercially available square conductor dimension

Hint: In typical hollow conductors, the size of the cooling channel represents between 20 and 40% of the total conductor area. You can use this catalogue: <https://www.luvata.com/products/hollow-conductors#square-with-round-hole>

- Compute the maximum current density in the active area of the selected conductor
- Compute the cooling channel area

- Exercise 3a: coil design – size and geometry
 - Compute the space taken by the coil windings at the magnet extremities, and check that it fits with your initial assumption (iterate if necessary)

Hints:

1/ Consider an insulation thickness between conductors of 1 mm and an additional ground insulation around the coil surface of 2 to 3 mm

2/ Consider a minimum bending radius of 3x the conductor width in the windings to limit the deformation of the conductor (cooling channel deformation and keystoneing)

- Compute the approximate total conductor length
- Compute the total volume and mass of conductor

- Exercise 3b: coil design – electrical parameters

- Set the maximum temperature increase you will allow in the coils

Hint: to avoid degradation of the epoxy resin insulation of the coil, the magnet shall not operate beyond 60°C for long periods

- Compute the resistance and maximum dissipated power of one coil

Hint: remember that resistivity varies with temperature

- Compute the resistance and maximum dissipated power of the magnet (neglecting internal connections)

- Compute the maximum resistive voltage in the circuit (2 magnets in series) and check that it fits with the power converter rating

Hint: remember that magnets need to be connected to the power converter

- Compute the magnet inductance

- Compute the circuit inductance (neglecting the inductance of the cables)

- Exercise 3c: coil design – cooling parameters
 - Compute the required total cooling flow per magnet
 - Set the number of (parallel) cooling circuits of the magnet

Hint: Typically, the number of cooling circuits matches the number of coils. In some cases, coils can be split in several cooling circuits of identical length, but this solution is much less practical for manufacturing

- Compute the water velocity in the cooling channel of the conductor

Hint: To avoid erosion on the long term, this shall be kept below 3 m/s

- Compute the required pressure differential and check it fits with the cooling infrastructure parameters (iterate if necessary)
- Compute the Reynolds number

Hint: To ensure efficient cooling, the flow shall be turbulent but not excessively (typically between ~ 3000 and ~ 100000)

- Bonus exercise: magnet cycling

- To allow for energy savings, the beam operation team is considering to operate the magnets in cycled mode, following this cycle:

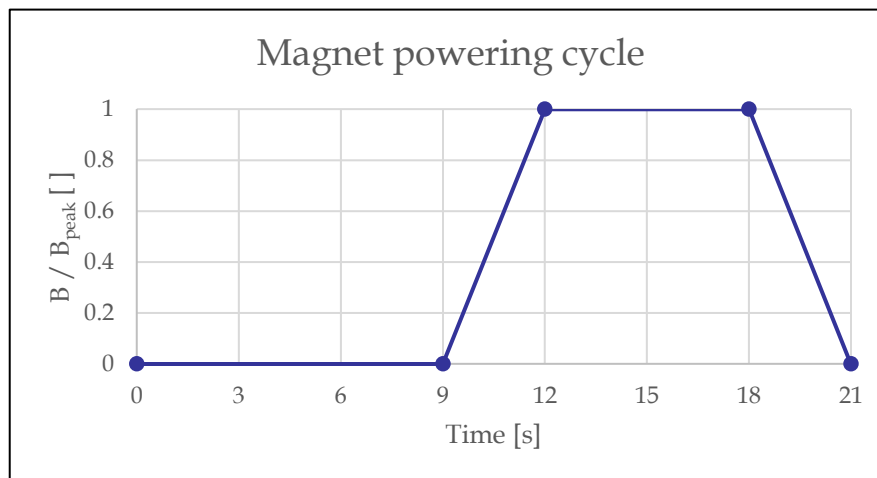

- Could this be feasible with the present converter rating? If not, which mitigation measure could you propose?
- Compute the dissipated power savings that this cycle could allow w.r.t. DC operation at peak field



ROOM TEMPERATURE MAGNETS - NUMERICAL DESIGN EXERCISE

J. Bauche, A. Milanese, J Borburgh, P. Thonet
CERN

CERN Accelerator School, Normal and Superconducting Magnets
St. Pölten, Austria, November 2023

- Guidelines for the numerical design
 - The objective is to evaluate numerically the analytical solution that you have established yesterday.
 - You can refer to the “Introduction to code for practical exercises” given on Wednesday 22/11 morning to get familiar with the use of FEMM.
 - Templates are provided on the EXCEL spreadsheet “RT magnet – TEMPLATES” on the Indico which contains 3 tabs:
 - The “C-SHAPE cross-section - TEMPLATE” helps retrieving the coordinates and corresponding LUA script lines of your yoke and coil geometry from your magnet parameters, with aperture centre in (0,0)
 - The “Field homogeneity on X axis - TEMPLATE” helps plotting the field homogeneity $\Delta B/B_0$ from the FEMM output for the post-processing
 - The “Field harmonics - TEMPLATE” helps plotting the harmonics
 - In these templates, input cells are highlighted in green, where you can copy your FEMM outputs

- Exercise 1: establish the numerical model of your magnet
 - Define the coordinates of your yoke and coil cross-section geometry
 - Create the model in FEMM following the “Walk-through FEMM example” given in the “Introduction to code”:
 - Create a new file and set the main problem parameters
 - (Declare a few variables for parametric analyses)
 - Load or prepare material properties, boundary conditions and circuit elements
 - Define the geometry and save your model
 - Mesh and solve
 - Post-process the model, checking in particular the shape of the flux lines, the flux density in the yoke, and in the aperture centre

Hint: Flux lines shall be perpendicular to the lower boundary of your model (mid-plane) and parallel to the other boundaries. Flux density in the iron shall not exceed 1.6 T, except in small regions around sharp corners. The flux density in the aperture centre shall be close to your analytical calculation.

- Exercise 2: more detailed post-processing
 - Perform a sanity check of your model:
 - Check the amplitude of the fringe field at the background boundaries. Enlarge the background where the amplitude is too high ($< 1\%$ of B_0)
 - Check that the mesh size doesn't affect significantly your results: reduce it by a factor 2 and check that the field quality doesn't change significantly
 - Compute the following quantities:
 - Magnetic stored energy and inductance
 - Lorentz forces on coils and magnetic forces on yoke

Hint: Remember that this is a 2D simulation. The 3D values are extrapolated from the length that you have defined in your model parameters

- Compute the field on the mid-plane and on the GFR boundary and check that the field error dB/B_0 is within specification

Hint: Remember that the field quality shall be achieved over the whole specified dynamic range

- Exercise 3: pole profile optimization
 - If the field quality in the GFR is not within specification, optimize it by modifying the pole profile:
 - Reduce slightly the magnetic gap at the pole extremities by adding “shims”

Hint: The “Kashikhin formula” calculated during the analytical exercise gives an estimation of the shim cross-section area

- If saturation appears at the pole extremities, you can add pole end chamfers to limit the flux concentration

Hint: Excessive saturation at the pole extremities typically result in a significant variability of the field quality over the dynamic range

- Bonus exercise: field harmonics

- Compute the normalized field harmonics at a radius of 20 mm with the script *multipoles_femm.lua*
- Compute the field homogeneity on the mid-plane based on the reconstruction from the harmonics

$$\frac{\Delta B}{B_0} = b_2 \frac{x}{R} + b_3 \left(\frac{x}{R}\right)^2 + b_4 \left(\frac{x}{R}\right)^3 + \dots$$

- dB/B_0 is in units of 10^{-4}
- b_n is in units of 10^{-4} , with n the harmonic number (2 for quad, 3 for sextupole, etc.)
- R is the reference radius for harmonics calculation, in units of distance
- x is the radius at which you compute the dB/B , in units of distance

Units of distance for x and R can be any ([mm] or [m]), but shall be identical for both.