CASE STUDY - TUTORIAL

NUMERICAL DESIGN OF A NORMAL-CONDUCTING, IRON-DOMINATED ELECTRO-MAGNET USING FEMM 4.2¹

Th. Zickler, CERN, 2019

1. INTRODUCTION

Finite Element Method Magnetics (FEMM) written by David Meeker is a finite element package for solving 2D planar and axisymmetric problems in low frequency magnetics and electrostatics. It is powerful and simple and therefore makes an excellent starting point for learning FEA. The program runs under Windows. The program can be obtained via the FEMM home page at <http://www.femm.info/wiki/HomePage>. The package is composed of an interactive shell encompassing graphical pre- and post-processing, a mesh generator, and various solvers. A powerful scripting language, Lua 4.0, is integrated with the program. Lua allows users to create batch runs, describe geometries parametrically, perform optimizations, etc. Lua is also integrated into every edit box in the program so that formulas can be entered instead of numerical values, if desired (detailed information on Lua is available from <http://www.lua.org>). There is no hard limit on problem size - maximum problem size is limited by the amount of available memory.

The purpose of this document is to present a step-by-step tutorial to help the students get "up and running" with FEMM. In this document, the solution for the normal-conducting, iron dominated electro-magnet is considered.

¹ This text is based on the original tutorial written by David Meeker

2. MODEL CONSTRUCTION AND ANALYSIS

This will take you through a step-by-step process to analyze the magnetic field of a classical C-shaped accelerator magnet. The magnet to be analyzed is pictured in Figure 1.

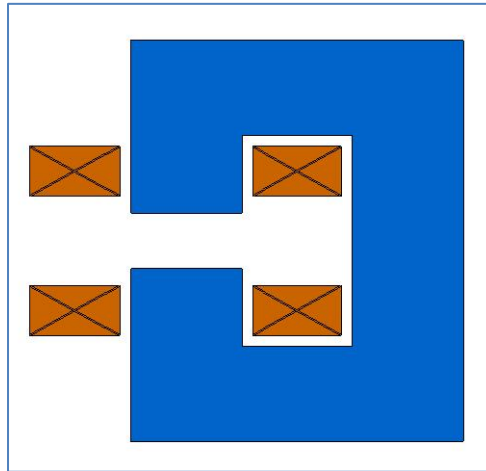

FIGURE 1

The yoke and coil dimensions shall be determined by the students in a first exercise (analytical design) together with the main parameters of the magnet.

Due to the symmetry around the x-axis, one can model only the upper half of the magnet. By convention positive currents flow in the into-the-page direction.

2.1 CREATE A NEW MODEL

Run the FEMM application by selecting `femm 4.2` from the `femm 4.2` section of the Start Menu. The default preferences will bring up a blank window with a minimal menu bar.

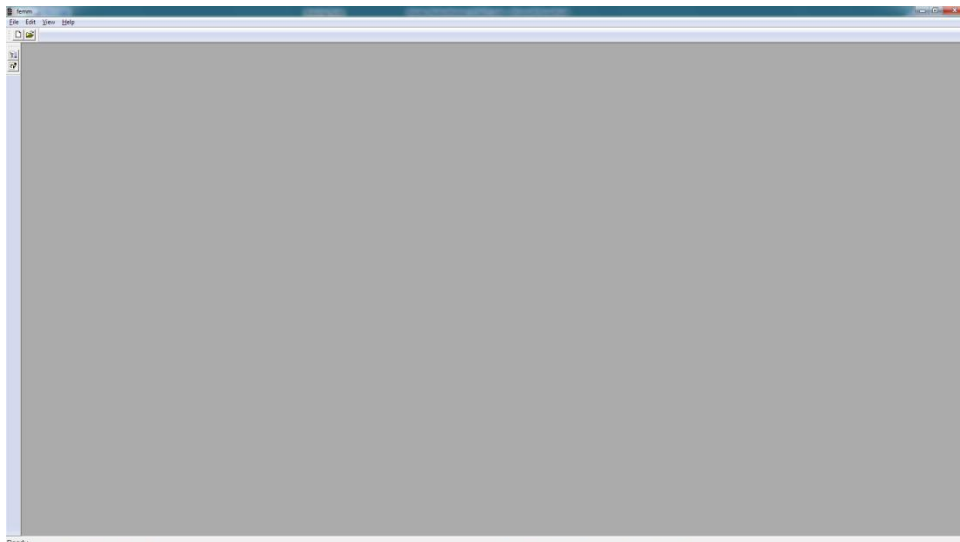

Select `New` from the main menu. A dialog will pop up with a drop list allowing you to select the type of new document to be created. Select the `Magnetics Problem` entry and hit the `OK` button. A new blank magnetics problem will be created, and a number of new toolbar buttons will appear.

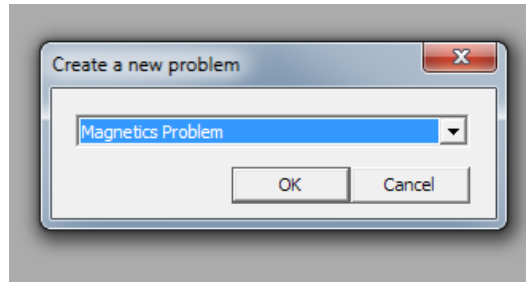

2.2 SET PROBLEM DEFINITION

The first task is to tell the program what sort of problem is to be solved. To do this, select **Problem** from the main menu. The **Problem Definition** dialog will appear. Set **Problem Type** to **Planar**. Make sure that **Length Units** is set to **Millimeters** and that the **Frequency** is set to 0. At this stage, also the length of the model can be entered by using the **Depth** field. When the proper values have been entered, hit the **OK** button.

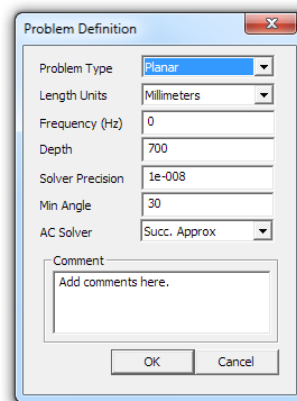

We can adjust the view so that it will contain the entire solution region. Select **View|Keyboard** from the main menu to bring up a dialog that allows you to specify the extents of the visible screen. When ready hit the **OK** button and the screen will then be rescaled to the smallest rectangle that contains the specified region.

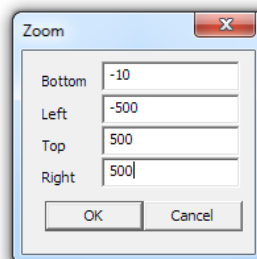

2.3 DRAW BOUNDARIES

The first task is to draw boundaries for the solution region. Fundamentally, finite element solvers mesh and find a solution over a finite region of space that contains the objects of interest. In this case, we will choose our solution region to be a rectangle extending about 2 times the dimension of the magnet yoke in the directions left, right and upwards (Note that the horizontal center line (=x-axis) is the symmetry axis which is already a boundary line for the solution region).

First, node points need to be defined that bound the rectangle. To draw these node points, select the `Operate on nodes` button from the tool bar (this is the farthest button on the left with a small black box). Place the four nodes on the plane either by moving the mouse pointer to the desired location and pressing the left mouse button, or by pressing the <TAB> key and manually entering the point coordinates via a popup dialog.

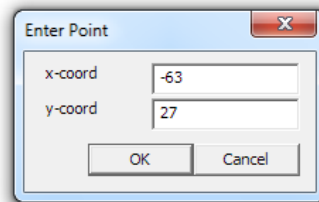

Select the `Operate on segments` toolbar button (second button from the left with a blue line). To select a node to be the endpoint of a line, click near the desired endpoint with the left mouse button. Draw a line by selecting the second node; a line will appear linking the nodes as soon as the second point is selected. Continue in this way with the other points until the rectangle is complete.

Instead of straight line, one can also draw arcs. In this case select the `Operate on arc segments` toolbar button (third button from the left with a blue arc). Draw an arc by selecting two points. After the second point has been selected a dialog will appear asking you for some attributes of the arc. In FEMM, arcs are approximated by a series of small, straight lines. The `Max. segment` specifies the coarseness with which the arc is divided into sections.

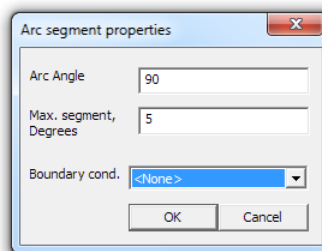

2.4 DRAW COIL AND IRON YOKE

Now, the coils and the iron yoke can be drawn. Switch back to Nodes mode by pressing the `Operate on nodes` toolbar button. For each region, place nodes defining the extents of the region. Select the `Operate on segments` toolbar button so that lines can be drawn connecting the points. By selecting the nodes defining the region in sequence, one obtains lines between each of the nodes. Repeat this operation until all regions are defined.

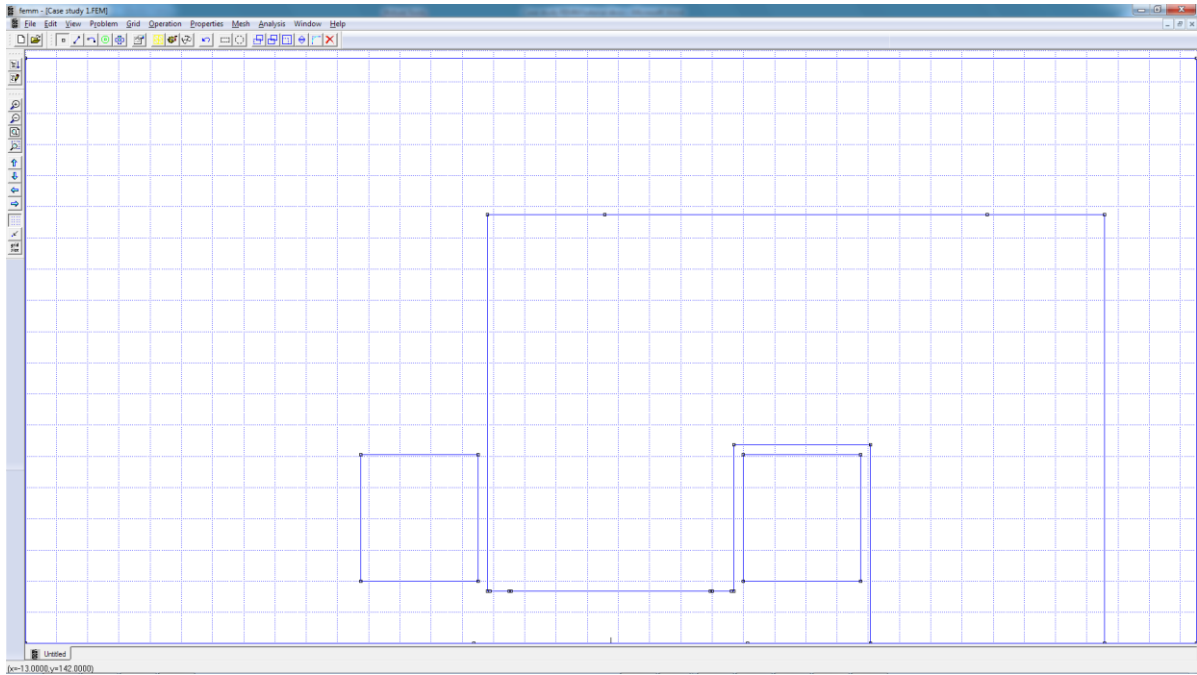

2.5 PLACE BLOCK LABELS

Now click on the Operate on Block Labels toolbar button denoted by concentric green circles. Place a block label in each of the regions (don't forget the air region outside the yoke region). Like node points, block labels can be placed either by a click on the left mouse button, or via the <TAB> dialog. The program uses block labels to associate materials and other properties with various regions in the problem geometry. Next, we will define some material properties, and then we will go back and associate them with particular block labels.

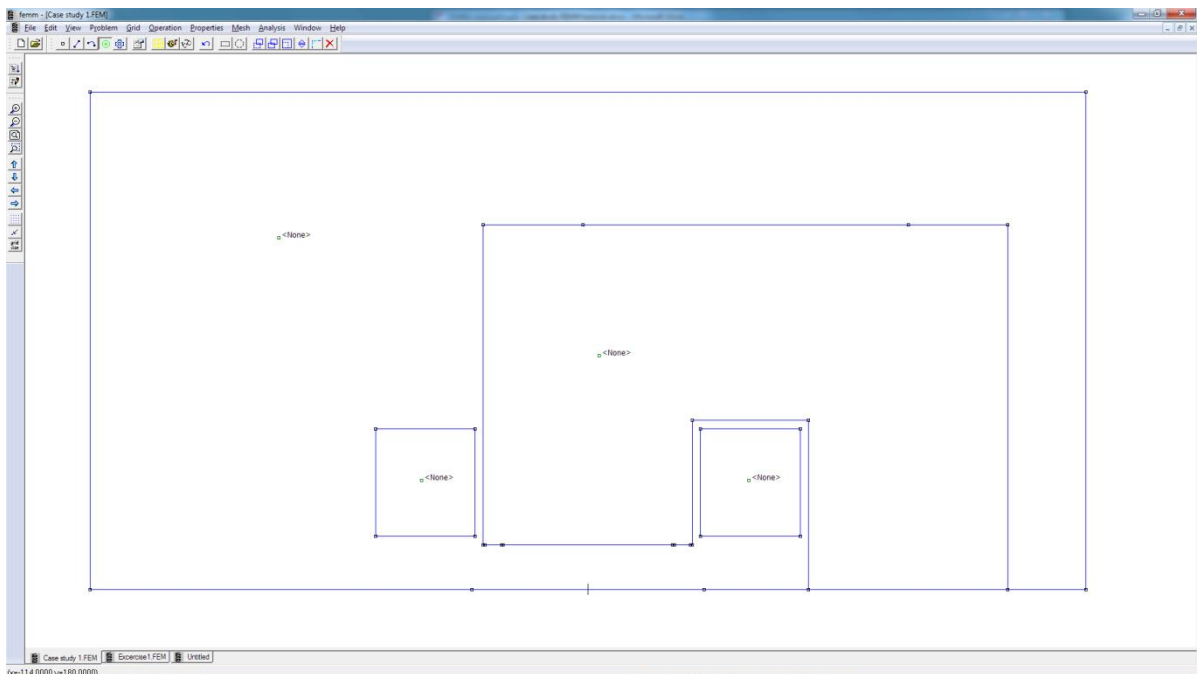

2.6 ADD MATERIALS TO THE MODEL

Select Properties|Materials Library from the main menu. Then drag-and-drop Air from Library Materials to Model Materials to add it to the current model. Go into the Solid Non-Magnetic Conductors folder and drag Copper into Model Materials. As yoke material choose Cold rolled low carbon strip steel in folder Metals Handbook DC Magnetization Curves. Click on OK.

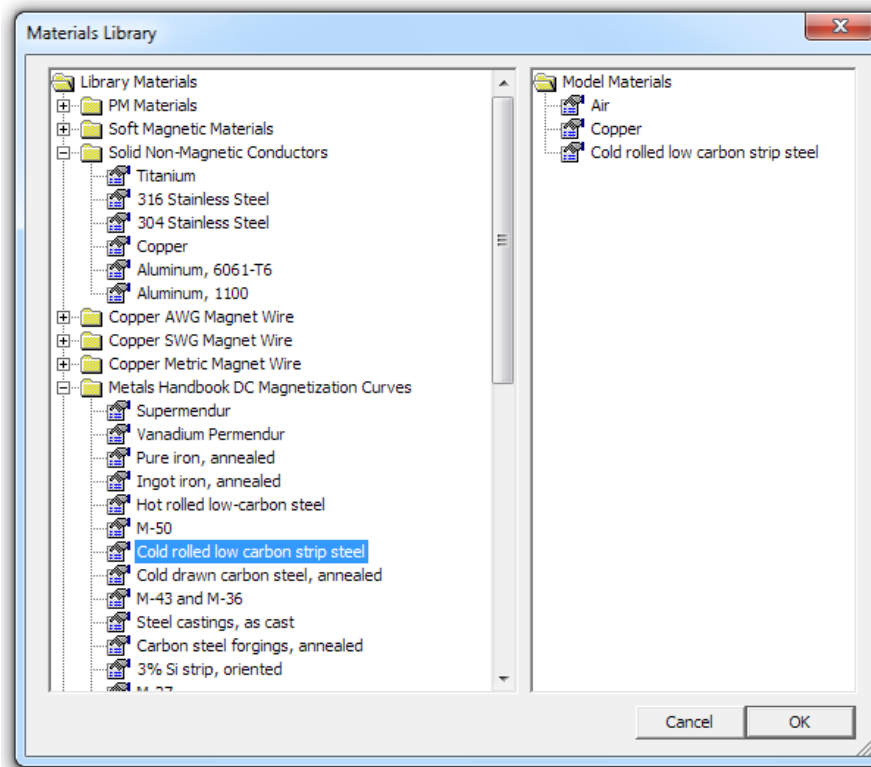

The properties of selected materials are sufficiently defined now. However, if you want to change them you can do this by clicking on Properties|Materials in the main menu and selecting the material to be changed in the pull-down list Property Name. The click on Modify Property. We will change here the properties of the Cold rolled low carbon strip steel.

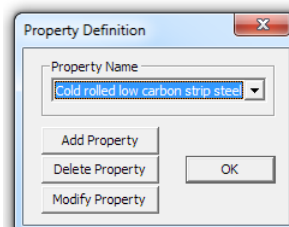

Once the Block Property window is open select Laminated in-plane from the Special Attributes: Lamination & Wire Type section. Set the Lam thickness, mm to 1 and the Lam fill factor to 0.98 to take into account that the yoke will be made of 1 mm thick steel laminations.

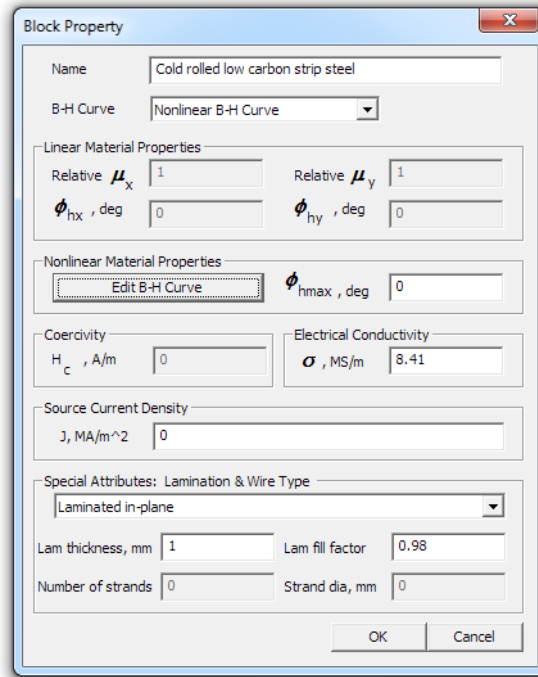

Also the magnetic properties and in particular the B-H data of the steel can be changed here. For entering or modifying Nonlinear Material Properties press the Edit B-H Curve button and the B-H Curve Data dialog box will open.

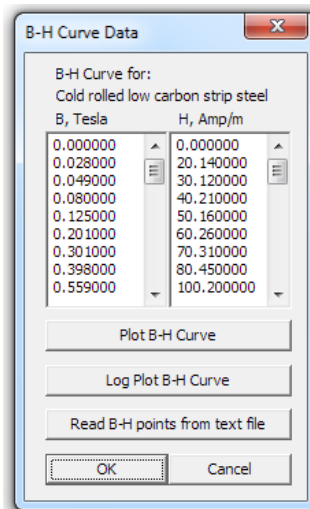

After you are done entering or changing your B-H data points, it is a good idea to view the B-H curve to see that it looks like it is “supposed” to. This is done by pressing the Plot B-H Curve button or the Log Plot B-H Curve button on the B-H data dialog. You should see a B-H curve that looks something like the curve pictured below. The boxes in the plot represent the locations of the entered B-H points, and the line represents a cubic spline derived from the entered data.

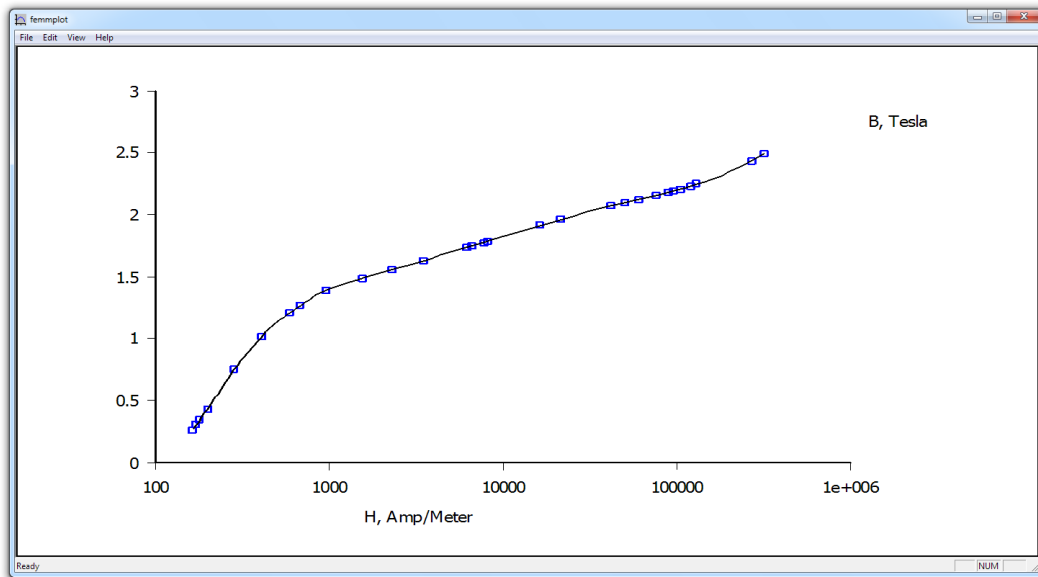

For more information see the manual.

2.7 ADD A "CIRCUIT PROPERTY" FOR THE COIL

Select `Properties | Circuits` from the main menu. On the dialog that appears, push the `Add Property` button to create a new circuit property. Name the circuit by replacing the `New Circuit name` with `Coil`. Specify that the circuit property is to be applied to a wound region by selecting the `Series` radio button. Enter the current value in `Circuit Current`. Click on `OK` for both the `Circuit Property` and `Property Definition` dialogs.

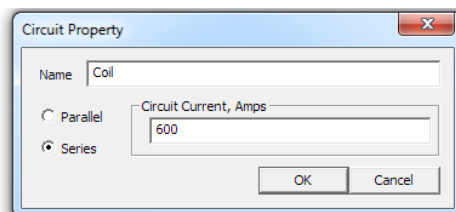

2.8 ASSOCIATE PROPERTIES WITH BLOCK LABELS.

If not already activated, click on the `Operate on Block Labels` toolbar button. Right click on the block label node in the air region outside the coil. The block label will turn red, denoting that it is selected. Press space to open the selected block label (instead of pressing the space bar, one can use the `Open up Properties Dialog` toolbar button). A dialog will pop up containing the properties assigned to the selected label. Set the `Block type` to `Air`. Uncheck the `Let Triangle choose Mesh Size` checkbox and enter a number for the `Mesh size`. The mesh size parameter defines a constraint on the largest possible elements size allowed in the associated section. The mesher attempts to fill the region with nearly equilateral triangles in which the sides are approximately the same length as the specified `Mesh size` parameter. When the “`Let Triangle choose Mesh Size`” box is checked, the mesher is free to pick its own element size, usually resulting in a somewhat coarse mesh. Click on `OK`.

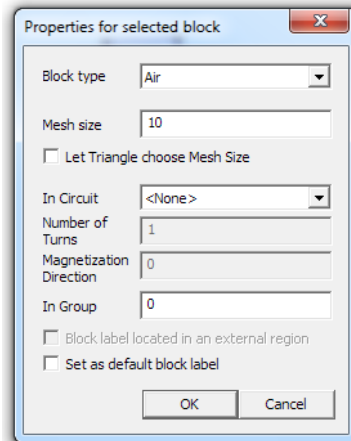

The block label will then be labeled as Air, and a circle will appear about the block label indicating the approximate mesh size in the associated region.

Repeat the same for the block label node inside the first coil region. The Block type for the coils has to be set to Copper. We want to assign currents to flow in this region, so select the Coil circuit from the In Circuit drop list. The Number of turns edit box will become activated if a series-type circuit is selected for the region (e.g. the Coil property that was previously defined). Enter the number of turns for this region, denoting that the region is filled turns wrapped in a counter-clockwise direction (*i.e.* positive turns in the right-hand-screw rule sense). Click on OK.

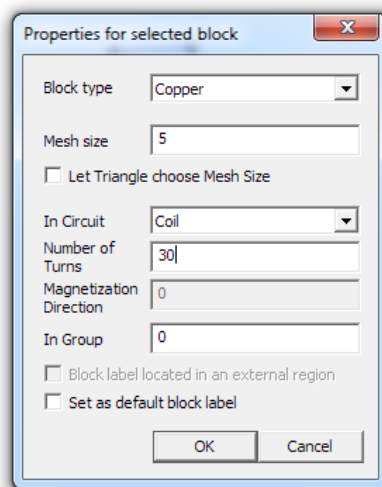

Repeat the same procedure for the second coil region but set the negative sign in front of the number of turns to define that the current direction in this coil is negative. Click on OK.

In the last operation, set the Block type for the yoke region to Cold rolled low carbon strip steel and click on OK.

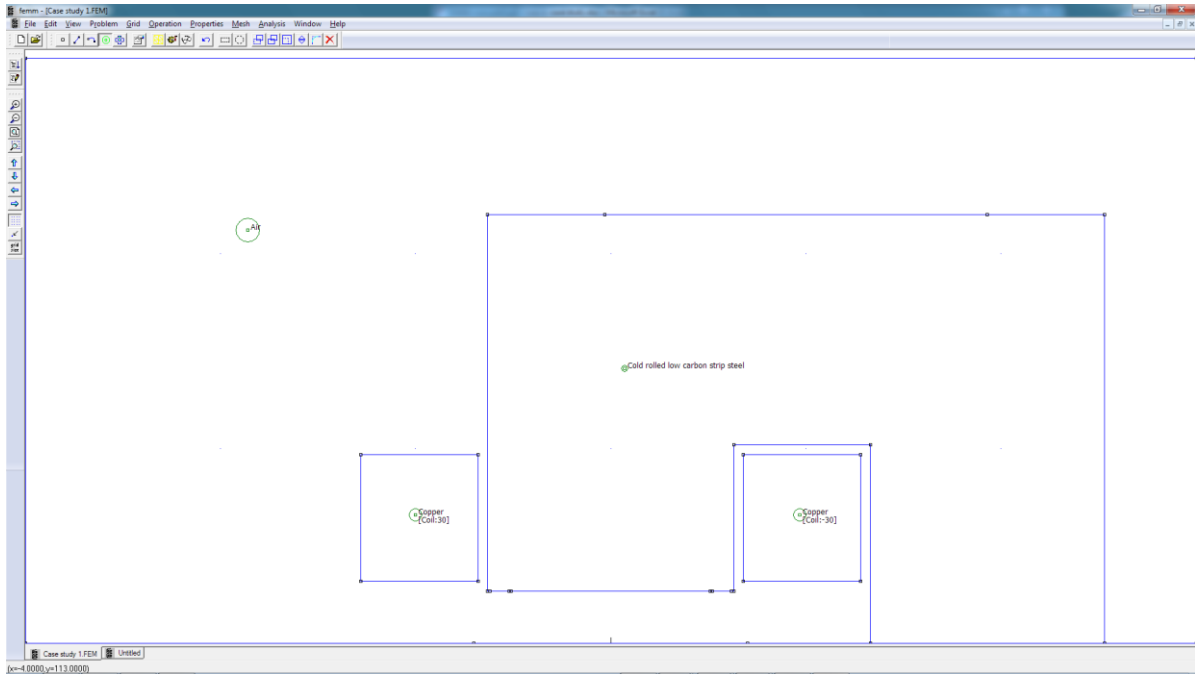

2.9 CREATE BOUNDARY CONDITIONS

Select **Properties | Boundary** from the menu bar, and then click on the **Add Property** button. Replace the name **New Boundary** with **Dirichlet** and select **Prescribed A** as BC Type.

With this type of boundary condition, the vector potential, A , is prescribed along a given boundary. This boundary condition can be used to prescribe the flux passing normal to a boundary, since the normal flux is equal to the tangential derivative of A along the boundary. In our case we leave all parameters at zero. This means that you have just defined a Dirichlet boundary condition with the vector potential equals zero which means zero magnetic flux through the plane. Next you have to assign this condition to a particular part of the model (i.e. the boundary of your background air region).

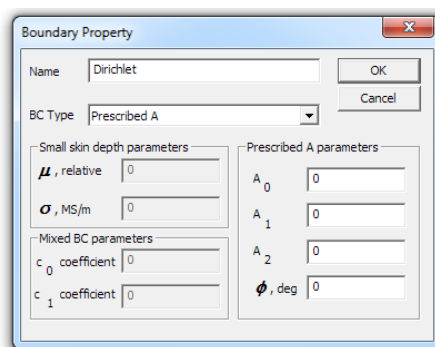

Select **Lines** from the toolbar then right click on the left side of the background region. When it turns red you have selected it. Now press space bar and the **Segment Property** window will appear. From the top drop box change the segment type from **<None>** to **Dirichlet**. The **Segment Property** dialog box allows you also to change the element size along the selected line. After the line properties have been modified click on **OK**. Repeat this process for the right side and the top side of the background region.

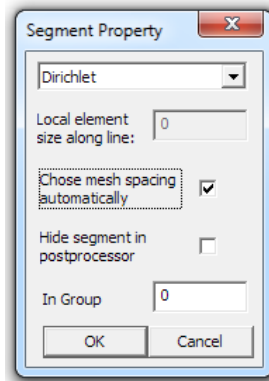

Note that the Neumann boundary condition (normal derivative of vector potential $\partial A/\partial n = 0$) is set automatically since the first-order triangle finite elements give a $\partial A/\partial n = 0$ boundary condition by default. Therefore, no specific boundary condition needs to be set for the symmetry axis (the bottom line of the background region).

2.10 GENERATE MESH AND RUN FEA

Now save the file and click on the toolbar button with yellow mesh. This action generates a triangular mesh for your problem. If the mesh spacing seems to fine or too coarse you can select block labels or line segments and adjust the mesh size defined in the properties of each object. Once the mesh has been generated, click on the “turn the crank” button to analyze your model.

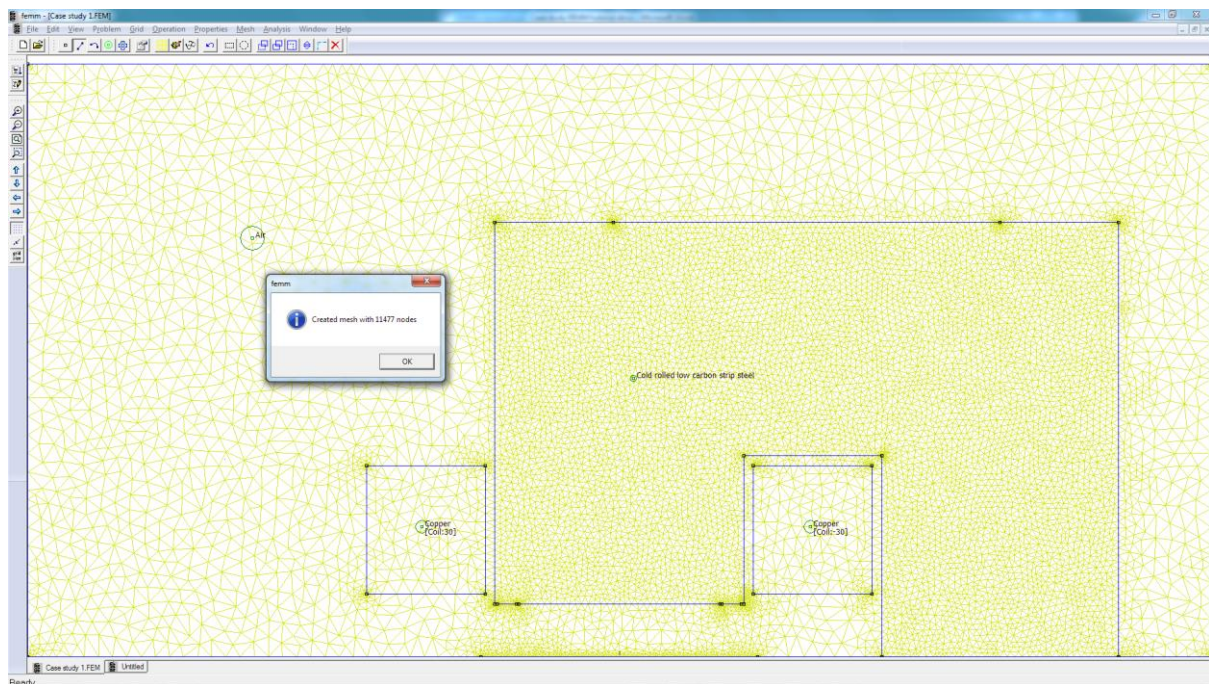

Processing status information will be displayed. If the progress bars do not seem to be moving then you should probably cancel the calculation. This can occur if insufficient boundary conditions have been specified. For this particular problem, the calculations should be completed within a few seconds. There is no confirmation for when the calculations are complete; the status window just disappears when the processing is finished.

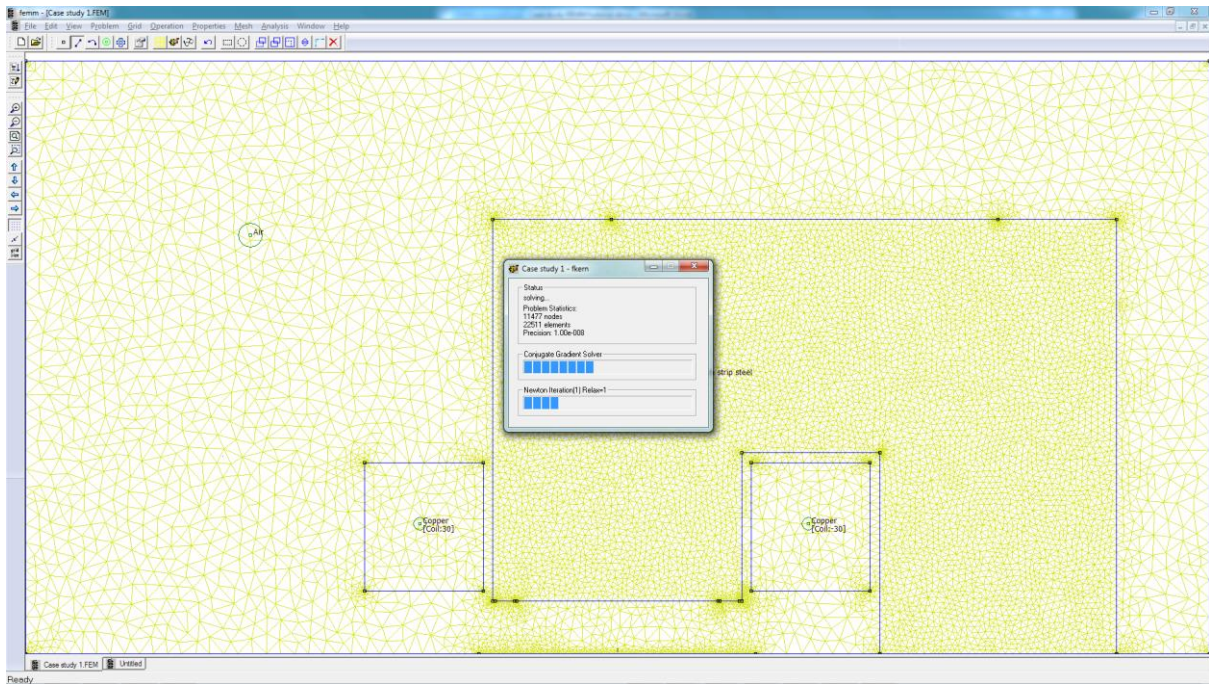

3. ANALYSIS RESULTS

Click on the glasses icon to view the analysis results. A post-processor window will appear. The post-processor window will allow you to extract many different sorts of information from the solution.

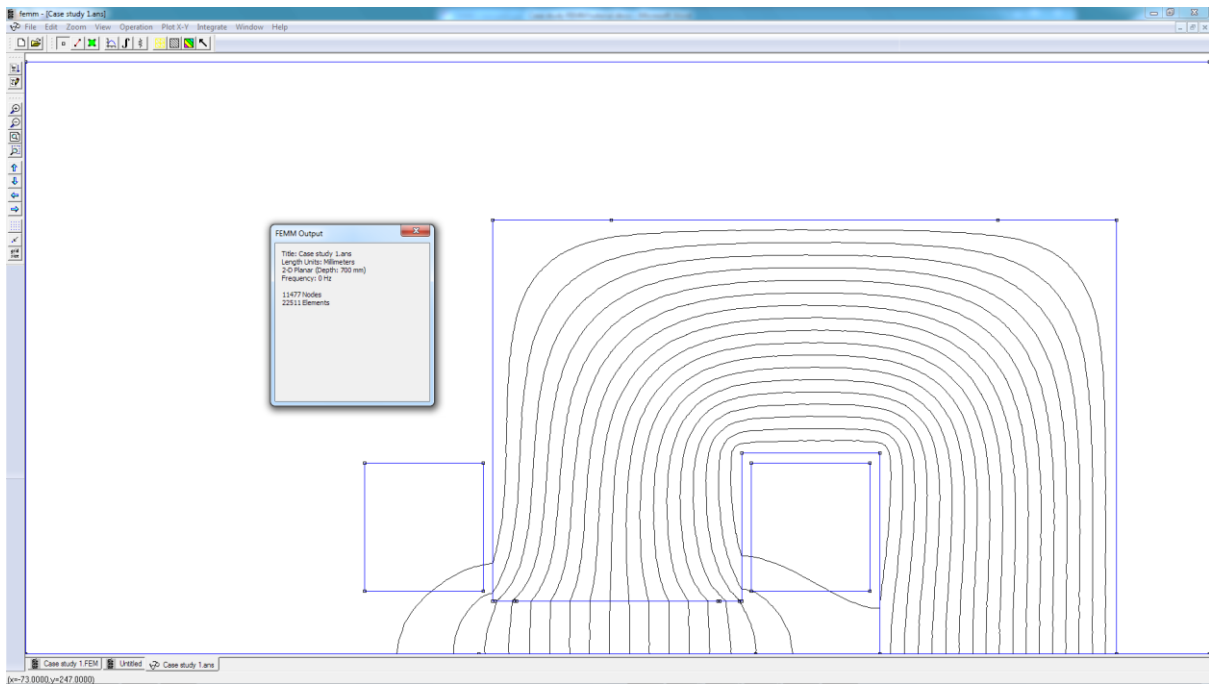

3.1 POINT VALUES

Just like the pre-processor, the post-processor window has a set of different editing modes: Point, Contour, and Area. The choice of mode is specified by the mode toolbar buttons, *i.e.* where the first button corresponds to Point mode, the second to Contour mode, and the third to Area mode. By default, when the program is first installed, the post-processor starts out in Point mode. By clicking on any point with the left mouse button, the various field properties associated with that point are displayed in the floating FEMM Output window. Similar to drawing points in the pre-processor, the location of a point can be precisely specified by pressing the <TAB> button and entering the coordinates of the desired point in the dialog that pops up.

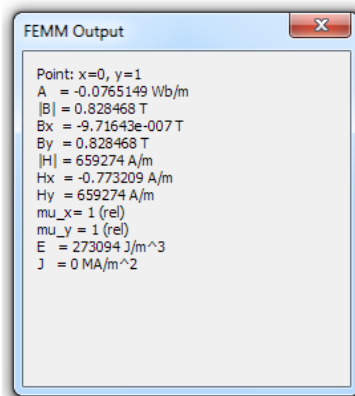

3.2 COIL TERMINAL PROPERTIES

With FEMM, it is straightforward to determine the inductance and resistance of the coil as seen from the coil's terminals. Press the button to display the resulting attributes of each Circuit Property that has been defined.

Since only one half of the magnet has been modelled, the values need to be multiplied by two to get the total magnet resistance and inductance. However, the problem does not take into account the coil heads on both ends of the magnet, so the results will be significantly lower than on a real magnet.

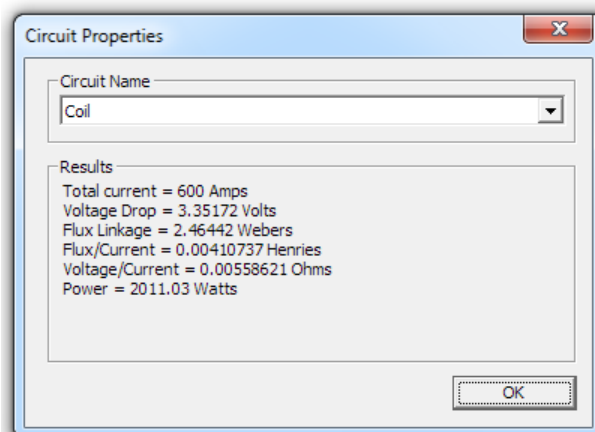

3.3 PLOTTING FIELD VALUES ALONG A CONTOUR

FEMM can also plot values of the field along a user-defined contour. Here, we will plot the flux density along the center line of the yoke. Switch to Contour mode by pressing the Contour Mode toolbar button. You can now define a contour along which flux will be plotted. There are three ways to add points to a contour:

1. *Left Mouse Button Click* adds the nearest input node to the contour;
2. *Right Mouse Button Click* adds the current mouse pointer position to the contour;
3. *<TAB> Key* displays a point entry dialog that allows you to enter in the coordinates of a point to be added to the contour.

Then, press the Plot toolbar button. Hit OK in the X-Y Plot of Field Values pop-up dialog—the default selection is magnitude of flux density. If desired, different types of plot can be selected from the drop list on this dialog.

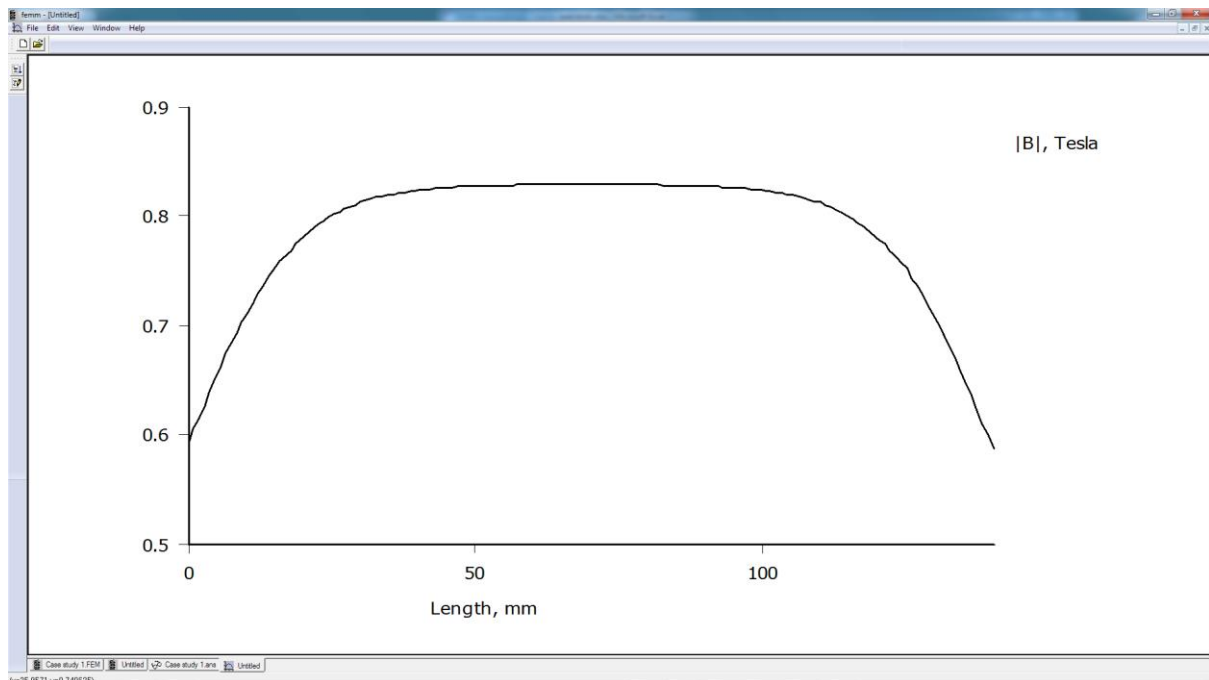
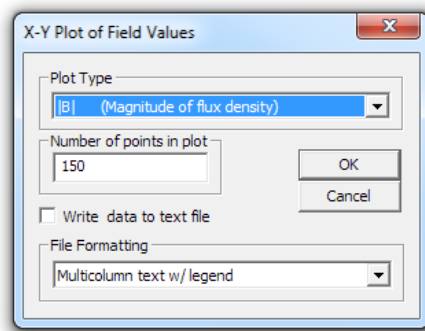

3.4 PLOTTING FLUX DENSITY

By default, when the program is first installed, only a black-and-white graph of flux lines is displayed. Flux density can be plotted as a color density plot, if you so desire. To make a color density plot of flux, click on the purple shaded toolbar button to generate a color flux density plot. When the dialog box comes up, select the Flux density plot radio button and accept the other default values. Click on OK.

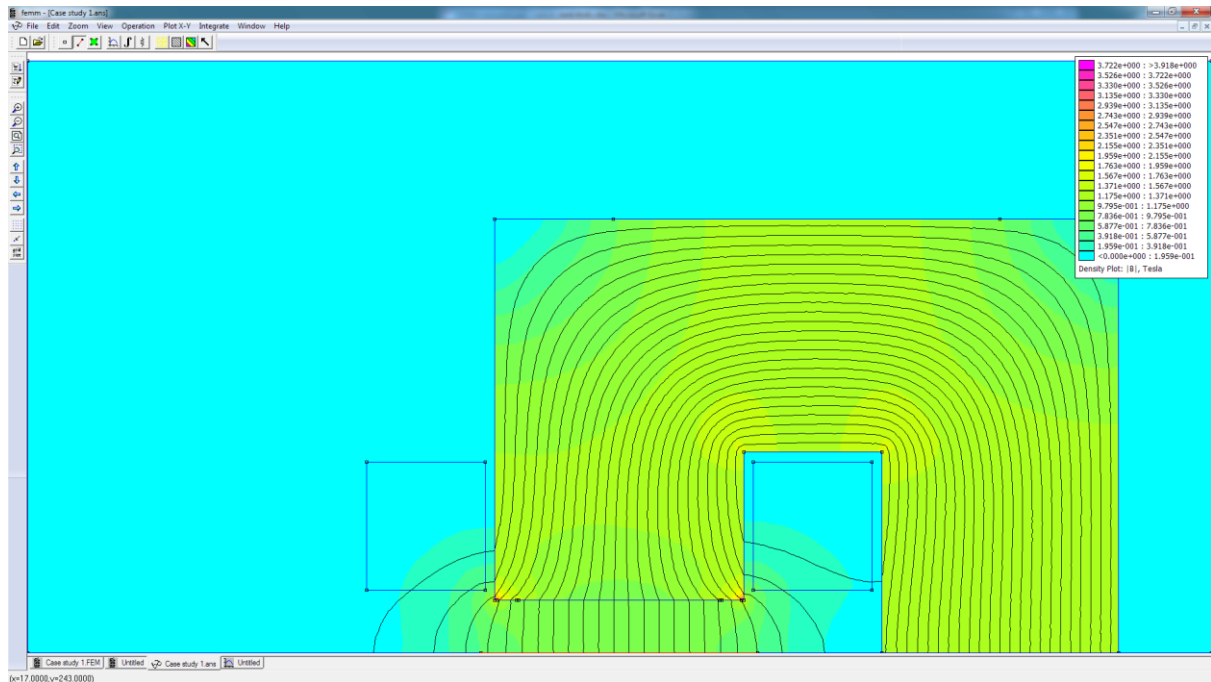
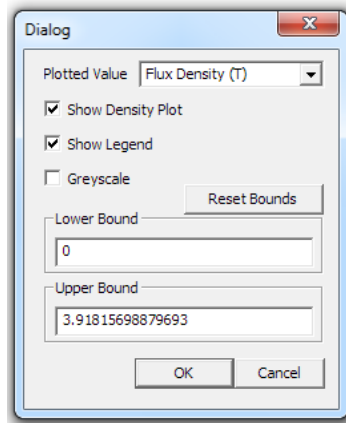

4. CONCLUSIONS

You have now completed your first model of a magnetic problem with FEMM. From this basic introduction, you have been exposed to the following concepts:

- How to draw a model using nodes, segments, arc, and block labels;
- How to add material to your model and how to assign them to regions;
- How to specify the finite element mesh size;
- How to define boundary for your model;
- How to define and apply boundary conditions;
- How to analyse a problem;
- How to inspect local field values;
- How to plot field values along a line;
- How to compute inductance and resistance;
- How to display colour flux density plots.

Hopefully, this tutorial has provided you enough of the basics of FEMM so that you can explore more complicated problems.