

fine-structure constant times the width of the $\Sigma^{*}(1385)$ or $0.26 \text{ MeV}/c^2$ and that the electric form factor of the lead nucleus $F(t)$ equals 1 over the t range of interest [$-t < 10^{-3} (\text{GeV}/c)^2$]. Using the observed branching ratio of 88% for the decay mode $\Sigma^{*}(1385) \rightarrow \Lambda^0 \pi^-$ and a 64% branching ratio for the decay mode $\Lambda^0 \rightarrow p + \pi^-$, we estimate a yield of 53 events whereas we observe at most two events from lead in this t range and in the range of mass values $1.375 \leq m_{\gamma^*} \leq 1.405 \text{ GeV}/c^2$. We regard this absence of events as evidence for U -spin conservation in electromagnetic transitions and place an upper limit on the partial decay width $\Gamma(\Sigma^{*}(1385) \rightarrow \Sigma^- + \gamma) < 0.024 \text{ MeV}/c^2$.

We acknowledge the great assistance provided us by the staff of the Brookhaven National Laboratory and the advice and assistance given to us by the Brookhaven National Laboratory-Fermilab-Yale University hyperon beam group.

*Work supported in part by the National Science Foundation and the U. S. Energy Research and Development Administration.

†Present address: Department of Physics, University of Pennsylvania, Philadelphia, Penn. 19104.

‡Present address: Bell Laboratories, Holmdel, N. J. 07733.

§Present address: Stanford Linear Accelerator Center, Stanford, Calif. 94305.

¹V. Hungerbühler, H. Kraybill, R. Majka, J. N. Marx, P. Némethy, J. Sandweiss, W. Tanenbaum, W. J. Willis, I. J. Winters, M. Atac, S. Ecklund, P. J. Gollon, J. Lach, J. MacLachlan, A. Roberts, R. Stefanski, D. Theriot, and C. L. Wang, Nucl. Instrum. Methods **115**, 221 (1974).

²V. Hungerbühler, R. Majka, J. N. Marx, P. Némethy, J. Sandweiss, W. Tanenbaum, W. J. Willis, M. Atac, S. Ecklund, P. J. Gollon, J. Lach, J. MacLachlan, A. Roberts, S. Stefanski, D. Theriot, C. L. Wang, W. Cleland, E. Engles, Jr., D. I. Lowenstein, N. Scribner, and J. Thompson, Phys. Rev. D **10**, 2051 (1974).

³W. E. Ellis, R. R. Kinsey, T. W. Morris, and R. S. Panvini, Phys. Lett. **32B**, 140 (1970).

⁴See, for example, R. M. Edelstein, R. A. Carrigan, Jr., N. C. Hein, T. J. MacMahon, I. Nadelhaft, E. W. Anderson, E. J. Bleser, G. B. Collins, T. Fujii, J. Menes, and F. Turkot, Phys. Rev. D **5**, 1073 (1972).

⁵M. L. Good and W. D. Walker, Phys. Rev. **120**, 1955 (1960).

⁶Y. Nagashima and J. L. Rosen, University of Rochester Report No. UR-875-295, 1969 (unpublished).

Precision Measurement of the $K^- p \rightarrow \bar{K}^0 n$ Cross Section below $1.1 \text{ GeV}/c^*$

M. Alston-Garnjost, R. W. Kenney, D. L. Pollard, R. R. Ross, and R. D. Tripp
Lawrence Berkeley Laboratory, University of California, Berkeley, California 94720

and

H. Nicholson

Mt. Holyoke College, South Hadley, Massachusetts 01075

and

M. Ferro-Luzzi

CERN, 1211 Geneva 23, Switzerland

(Received 14 March 1977)

We report the results of a precise measurement of the $K^- p \rightarrow \bar{K}^0 n$ cross section between 515 and 1065 MeV/c in steps of 10 MeV/c. The statistical errors are less than 1%, a major improvement in accuracy over previous work. No evidence is found for the new $I=1 \bar{K}N$ resonances at 546 and 602 MeV/c reported recently by Carroll *et al.*

This Letter presents the results of a counter experiment designed to measure with high precision the total cross section for the reaction $K^- p \rightarrow \bar{K}^0 n$ in the momentum region from 515 to 1065 MeV/c. The charge-exchange cross section, being proportional to the sum of the squares of the differences between the $I=1$ and $I=0$ amplitudes

in each partial wave, is generally small and therefore is sensitive to small changes in either of them. Thus a precise measurement of the energy dependence of this cross section is a valuable indicator of resonant structure.

The experiment was performed in the low-energy separated beam¹ at the Brookhaven National

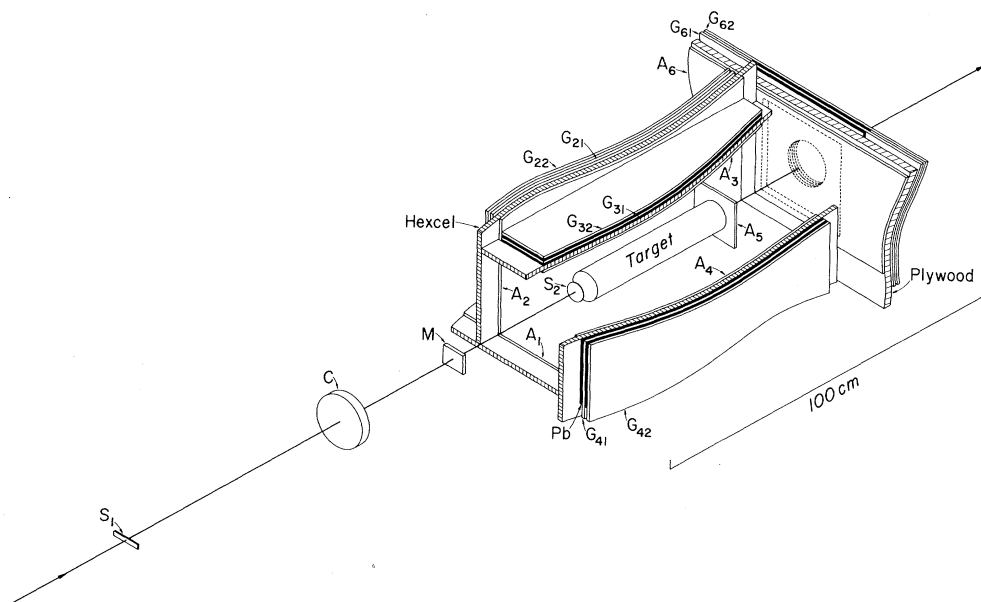

FIG. 1. Isometric projection of the apparatus.

Laboratory alternating-gradient synchrotron (AGS) using the apparatus shown in Fig. 1. The principle of the method is to veto all reactions containing charged particles or γ rays, leaving $K^-p \rightarrow K_L n$ as the only contributor to the counting rate. To achieve this a liquid-hydrogen target² was surrounded by a charged-particle veto box outside of which was a γ detector consisting of two layers of lead-scintillator sandwiches, each containing equal thicknesses (6.35 mm) of lead and scintillator. Care was taken to minimize the amount of material surrounding the target in order to make the apparatus as transparent as possible to K_L and neutrons while retaining sufficient opacity to γ rays to veto with good efficiency the all-neutral final states containing γ rays. For the chosen configuration the single- γ detection efficiency was calculated to be approximately 70%. This was sufficient to reduce corrections for contamination from unwanted neutral states to less than 2% at all momenta, the dominant contribution coming from the two- γ state $K_L n \pi^0$ above 800 MeV/c and the four- γ state $\Lambda \pi^0$ ($\Lambda \rightarrow n \pi^0$) below 800 MeV/c. The correction for K_L or neutrons interacting in the target and veto box was about 25%.

As seen in Fig. 1, the incident beam was defined by scintillation counters S_1 , M , and S_2 , while a Cherenkov counter C rejected pions and muons in the beam. Cherenkov light from these contaminants was collected by total internal re-

flection and used in anticoincidence (\bar{C}_π) while kaon-produced light passed through the radiator and was focused onto photomultipliers placed in coincidence (C_K) for positive identification. Although the π/K ratio in the beam ranged from 10 to 60, the kaons so identified contained fewer than 1% pions. The kaon intensity varied from 20 000 per pulse at the highest momentum to 400 per pulse at the lowest. The signature for a charge-exchange reaction was an incident kaon, $K = S_1 \cdot M \cdot S_2 \cdot \bar{C}_\pi \cdot C_K$, and no signal in any of the A or G counters: $K \cdot \bar{A} \cdot \bar{G}$ (see Fig. 1).

Empty-target rates, typically 12% of the full rates, were measured at each momentum and subtracted. The major contribution to this effect arose from $K^- \rightarrow \mu^- \nu$ decay where the muon had insufficient energy to penetrate to the charged-particle veto counters. To minimize this, counter S_2 was located directly in front of the target in a re-entrant pipe and viewed by means of an air light guide, while veto counter A_5 intercepted the beam immediately beyond the target. Because of the added stopping power of a full target, this contribution from K^- decays is not entirely removed by an empty-target subtraction. The calculated correction for this effect is momentum dependent and becomes as large as 15% at 750 MeV/c.

Corrections to the cross sections were made by means of a Monte Carlo program³ validated by detailed hand calculations. In addition to the four

corrections mentioned above, the only others which had more than a 2% effect on the cross section were (a) the attenuation of the beam in the target due to interaction and decay, a factor of 1.07–1.09, and (b) K_L decays inside the veto box, a factor of 1.03–1.04.

The largest correction and the one subject to the greatest uncertainty is the one mentioned previously which accounted for K_L and neutron interactions in the target and veto box. This requires a knowledge of the absorption cross sections in carbon and lead. For neutrons, these have been measured and can be well-fitted by an optical-model calculation.⁴ For K_L , the nuclear absorption cross section was parametrized as

$$\sigma = 10\pi[R + (\sigma_K/10\pi)^{1/2}]^2 \text{ mb},$$

where $R = 6.41$ fm for Pb and $R = 1.69$ fm for C. The K_L -nucleon cross section (σ_K) was obtained from the measured $K^\pm d$ cross sections above 450 MeV/c^{5,6} and below from analysis of bubble-chamber experiments.⁷ A visibility factor f_v , as introduced by Bricman *et al.*⁸ to represent the fraction of interactions producing a detectable signal in a counter, was assigned to K_L and neutron interactions in lead and scintillator. For K_L interactions in lead and scintillator and for n interactions in scintillator we used $f_v = 1$, while for n interactions in lead we adopted the parametrization of Bricman.^{8,9} The angular distributions for charge exchange required in the Monte Carlo calculation were obtained from a partial-wave analysis based on bubble-chamber experiments. The result is a correction factor nearly independent of momentum varying from 1.24 to 1.26, two-thirds of which comes from the interaction of K_L 's.

The calibration of the beam momentum was established by measuring, at a series of momenta, proton, antiproton, and deuteron times of flight over a 6.25-m path beyond the apparatus and by proton range curves in copper. These sets of measurements agree to within $\pm 0.5\%$ which we regard to be our absolute momentum uncertainty. The momentum resolution of the experiment, coming about equally from momentum spread of the beam and ionization loss in the target, is nearly constant and averages ± 7 MeV/c rms.

The final results for the charge-exchange cross section are listed in Table I and displayed in Fig. 2 as a function of the mean laboratory interaction momentum. The errors shown are statistical only and are smaller than $\pm 1\%$ over most of the energy region. The systematic uncertainty in over-

TABLE I. Cross section for the reaction $K^- p \rightarrow \bar{K}^0 n$ as a function of K^- lab momentum.^a

P_K (MeV/c)	σ (mb)	$\Delta\sigma$ (mb)	P_K (MeV/c)	σ (mb)	$\Delta\sigma$ (mb)
515	4.320	.077	828	4.342	.050
536	4.229	.059	838	4.458	.026
547	4.170	.056	848	4.419	.028
557	4.102	.055	858	4.509	.026
567	4.043	.048	868	4.617	.015
578	3.996	.057	878	4.684	.025
598	3.841	.049	888	4.621	.028
608	3.833	.054	898	4.674	.027
618	3.695	.047	907	4.694	.027
639	3.679	.044	917	4.933	.026
659	3.544	.058	927	5.003	.037
679	3.424	.030	937	5.178	.034
699	3.142	.039	947	5.276	.036
708	3.012	.032	957	5.599	.039
718	2.576	.037	968	5.802	.038
728	2.224	.022	979	6.151	.039
739	2.269	.026	990	6.230	.039
750	2.283	.030	1000	6.454	.042
760	2.741	.034	1011	6.885	.037
770	3.033	.028	1022	7.227	.043
779	3.295	.026	1033	7.604	.048
789	3.638	.030	1044	7.703	.045
799	3.908	.046	1055	7.810	.038
819	4.167	.049	1065	7.535	.043

^aOnly the statistical uncertainty is listed. There is, in addition, an overall systematic uncertainty of $\pm 3\%$.

all normalization, coming primarily from the absorption correction, is estimated to be $\pm 3\%$.

A comparison between the new cross sections and those previously available¹⁰ is displayed in Fig. 2, showing the dramatic improvement in accuracy (almost a factor of 10) made by this experiment. The agreement between our experiment and bubble-chamber data is exceedingly good below 1 GeV/c. Above that, we fall somewhat below most of the bubble-chamber points, but are significantly higher than the counter results of CERN–Université de Paris–Sud.⁸

The deep U-shaped valley apparent in the cross section in the vicinity of $\Lambda\eta$ threshold (725 MeV/c) is now clearly delineated. The cross section falls rapidly as the threshold is approached from below and appears to be nearly constant immedi-

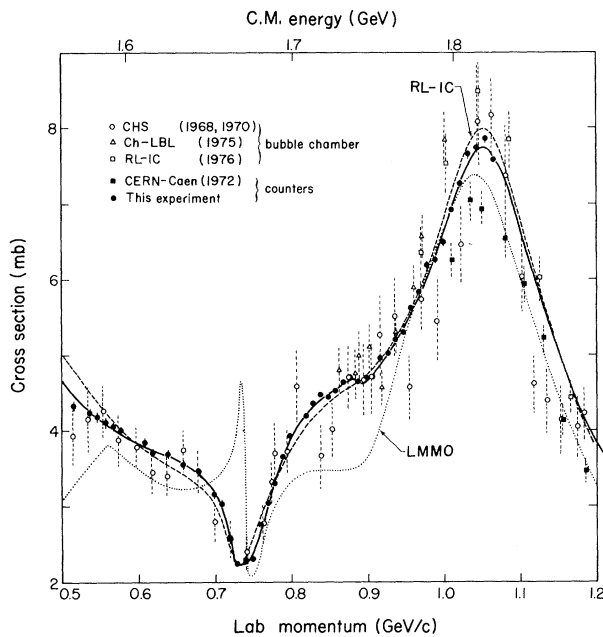

FIG. 2. Cross section for the reaction $K^- p \rightarrow \bar{K}^0 n$ vs lab momentum showing this experiment (closed circles) along with bubble-chamber (open symbols) and other counter results (Ref. 10). The CHS data points have been amended to conform with the current $K_S \rightarrow \pi^+ \pi^-$ branching fraction of 0.687. Our partial-wave fit (Ref. 12) is shown as a solid line while the dotted and dashed curves are predictions from two previous partial-wave analyses (Refs. 13 and 14).

ately above. At higher momenta there is a shoulder more evident than in the bubble-chamber data with a suggestion of a slight dip at $\Sigma^0 \eta$ threshold (888 MeV/c). There is no evidence for structure between 500 and 650 MeV/c where the results of Carroll *et al.*⁶ indicate two significant narrow enhancements in the $I=1$ part of the total cross section. Resonances here would be consistent with our lack of structure if they were in high partial waves (for example, D_{13} as suggested by Litchfield¹¹ for the enhancement at 546 MeV/c).

In the following Letter¹² we present a partial-wave analysis incorporating these as well as other $\bar{K}N$ data in which a satisfactory fit to our results is achieved. Figure 2 shows our fit to the charge-exchange cross section along with predictions from two recent partial-wave analyses,

The solution designated LMMO¹³ is incompatible with our data, while the solution of Gopal *et al.*¹⁴ although generally in reasonable agreement, fails to reproduce the shoulder between 800 and 900 MeV/c.

We are grateful to the Brookhaven AGS staff for their generous assistance and hospitality, to T. Kycia for the loan of the Cherenkov counter, and to T. Mast, J. Nelson, S. Shannon, and D. Neuffer for their assistance in earlier phases of this experiment. We also thank T. Daly, M. Long, and J. Taylor for their technical assistance throughout the experiment. One of us (H.N.) would like to thank the Faculty Grants Committee, the Research Corporation, and the University of Massachusetts Computing Center for financial support.

*This work was done with support from the U. S. Energy Research and Development Administration.

¹A. S. Carroll *et al.*, Brookhaven National Laboratory Experimental, Planning, and Support Technical Notes Nos. 54, 1972 and 64, 1973 (unpublished).

²Length, 40.8 cm; diameter, 8.2 cm; net density, 0.07024 gm/cm³.

³D. L. Pollard, thesis, Lawrence Berkeley Laboratory Report No. 5522, 1976 (unpublished).

⁴V. Franco, Phys. Rev. **140**, B1501 (1965).

⁵A. S. Carroll *et al.*, Phys. Lett. **45B**, 531 (1973).

⁶A. S. Carroll *et al.*, Phys. Rev. Lett. **37**, 806 (1976).

⁷V. Stenger *et al.*, Phys. Rev. **134**, B1111 (1964), and unpublished analysis of data of T. S. Mast *et al.*, Phys. Rev. D **14**, 13 (1976).

⁸C. Bricman *et al.*, Phys. Lett. **29B**, 451 (1969), and **31B**, 148 (1970); C. Bricman, thesis, Université de Paris-Sud Report No. A971, 1972 (unpublished).

⁹This is discussed further in M. Alston-Garnjost *et al.*, Phys. Rev. Lett. **35**, 1685 (1975).

¹⁰CHS: R. Armenteros *et al.*, Nucl. Phys. **B8**, 233 (1968), and **B21**, 15 (1970); Ch-LBL: M. Jones *et al.*, Nucl. Phys. **B90**, 349 (1975); RL-IC: B. Conforto *et al.*, Nucl. Phys. **B105**, 189 (1976); CERN-Caen: C. Bricman *et al.*, Ref. 8.

¹¹P. Litchfield, Phys. Lett. **51B**, 509 (1974).

¹²M. Alston-Garnjost *et al.*, following Letter [Phys. Rev. Lett. **38**, 1007 (1977)].

¹³A. Lea *et al.*, Nucl. Phys. **B56**, 77 (1973).

¹⁴G. Gopal *et al.*, Rutherford Laboratory Report No. RL 75-182, 1976 (unpublished).