



*Large Hadron Collider Project*

**LHC Project Report 910**

## **The Septa for LEIR Extraction and PS Injection**

J. Borburgh, M. Hourican, T. Masson, A. Prost  
CERN, Geneva, Switzerland

### **Abstract**

The Low Energy Ion Ring (LEIR) is part of the CERN LHC injector chain for ions. The LEIR extraction uses a pulsed magnetic septum, clamped around a metallic vacuum chamber. Apart from separating the ultra high vacuum in the LEIR ring from the less good vacuum in the transfer line to the PS this chamber also serves as magnetic screen and retains the septum conductor in place. The PS ion injection septum consists of a pulsed laminated magnet under vacuum, featuring a single-turn water cooled coil and a remote positioning system. The design, the construction and the commissioning of both septa are described.

*Presented at  
EPAC'06, Edinburgh, UK,  
June 26-30, 2006*

CERN,  
CH-1211 Geneva 23,  
Switzerland  
Geneva, June 2006

# THE SEPTA FOR LEIR EXTRACTION AND PS INJECTION

J. Borburgh, M. Hourican, T. Masson, A. Prost, CERN, Geneva, Switzerland

## Abstract

The Low Energy Ion Ring (LEIR) is part of the CERN LHC injector chain for ions. The LEIR extraction uses a pulsed magnetic septum, clamped around a metallic vacuum chamber. Apart from separating the ultra high vacuum in the LEIR ring from the less good vacuum in the transfer line to the PS this chamber also serves as magnetic screen and retains the septum conductor in place. The PS ion injection septum consists of a pulsed laminated magnet under vacuum, featuring a single-turn water cooled coil and a remote positioning system. The design, the construction and the commissioning of both septa are described.

## LEIR EXTRACTION SEPTUM

This chapter describes the results of the testing, the installation and the initial operational experience with this septum during the LEIR commissioning. As described in [1], the LEIR extraction septum consists of a single-turn magnet that is clamped around a stainless steel vacuum chamber. The main magnet parameters are presented in Table 1. The magnet cross section is shown in Fig. 1.

## Test Phase

Since the vacuum chamber designed for the magnet was already installed in the LEIR ring, and under vacuum, it was necessary to test the magnetic performance of the magnet using a test set up. The magnet was equipped with a 1 m long section of identical orbiting beam vacuum chamber which incorporated the magnetic screen, and a 1 m long straight tube in the magnet gap representing the extracted beam vacuum chamber. The magnetic field was verified using measurement coils. The voltage from the measurement coils was registered and by integrating the signal digitally off-line the field was reconstructed. The measurements showed that the nominal integrated gap field was reached at 28.0 kA, yielding a magnetic length of 849 mm for the magnet. Taking into account the precision of the field measurement, these values are coherent with the 3D finite element predictions.

The fringe field, defined as the integrated magnetic field measured at the mid plane of the magnet in the orbiting beam vacuum chamber and expressed as a fraction of the integrated gap field, was also measured. Due to the magnetic properties of the vertical vacuum chamber wall the maximum field reaches 1‰ at 25 mm from the vacuum chamber wall up to 35 mm, before it drops to 0.5‰ at 90 mm. The physics requirement of a fringe field of less than 1‰ close to the septum was hence confirmed. If required for physics, the fringe field can be further reduced by fully shielding the orbiting beam vacuum chamber with a mu-metal screen.

Following completion of the magnetic measurements, the septum was installed in the LEIR ring (see Fig. 2) and

pulsed at its design current. While minor vibrations in the vacuum chamber supports were detected, no fluctuations on the vacuum ( $10^{-11}$  mbar) were observed, which may have indicated mechanical damage to the vacuum chamber.

Table 1: Main parameters of the LEIR extraction septum ER.SMH40

Deflection angle	130	mrad
Integrated magnetic field	0.624	T.m
Integrated fringe field	1	‰
Gap height	48	mm
Magnet length	900	mm
Septum conductor thickness	4.5	mm
Effective septum thickness as seen by the beam	10	mm
Number of turns	1	
Peak design current	28.0	kA
Peak design current density in septum conductor	129	A/mm <sup>2</sup>
RMS current	750	A
Half sine pulse width	≈ 5	ms
Flat top duration	400	μs
Magnet inductance	2.3	μH
Magnet resistance	0.2	mΩ

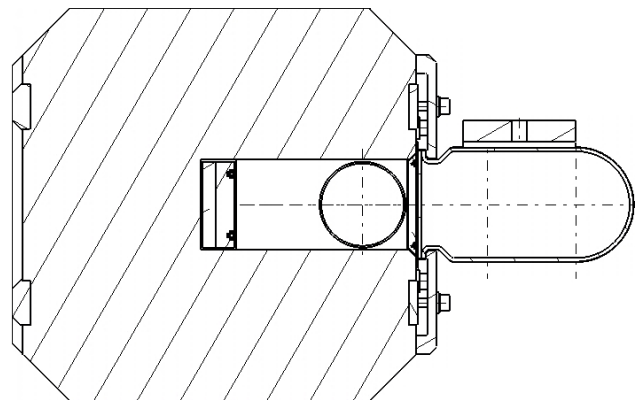

Figure 1: Cross sectional view of the LEIR extraction septum (from downstream). In the magnet gap the circular extraction chamber is visible, on the right the orbiting beam chamber is clamped on to the magnet.



Figure 2: LEIR extraction magnet (blue) installed in the ring.

The vacuum chamber (Fig. 3) which incorporates a NEG coating has shown no signs of deterioration following bake-out and first pulsed operation of the septum.

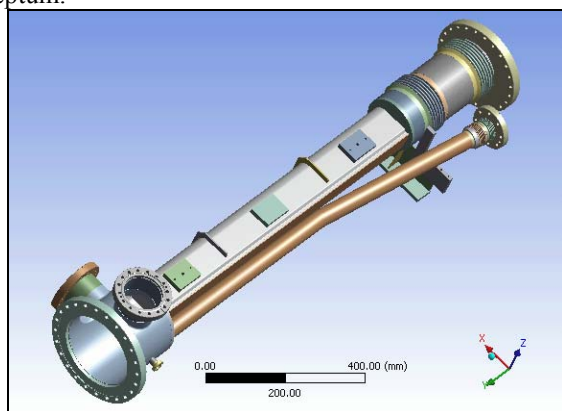

Figure 3: 3D Catia rendering of the vacuum chamber.

### Operational Experience

LEIR started extraction commissioning in April 2006. During this commissioning the dynamic vacuum observed just upstream of the magnet in the orbiting beam vacuum chamber was  $2.7 \times 10^{-11}$  mbar, while the static pressure was a factor of 2 lower.

In the extraction line, just downstream of the magnet the dynamic vacuum recorded was  $1.4 \times 10^{-11}$  mbar and the static pressure was also a factor 2 better. The magnet current used in the extraction septum depended on the machine settings and ranged from 28.5 kA to 29.7 kA. This was somewhat higher than its design current.

After the commissioning of LEIR ended in May, the magnet was dismantled to inspect the wear on the septum conductor insulation. Kapton® insulation and epoxy impregnated glass fibre sheet have been used for the

vertical surfaces, while the insulation between the septum conductor and the yoke was assured by a plasma coating of aluminium oxide on both the conductor and the magnet yoke. A future improvement of the septum conductor insulation consists of using moulded polyimide impregnated glass fibre sleeves to increase the insulation toughness and subsequently its expected lifetime.

### PS ION INJECTION SEPTUM

This chapter describes the design, construction and initial testing of the ion injection septum PI.SMH26. This septum magnet is used to inject the ion beam into the Proton Synchrotron (PS) at the end of the LEIR – PS transfer line.

The magnetic ion injection septum for the PS is of the single-turn, pulsed under-vacuum type. The vacuum tank, the mechanical support structure, the vacuum equipment and the magnet displacement systems, together with their spare, are recovered from the PE.SMH58 device (previously used for electron extraction in the PS ring during the LEP era) to reduce cost. These existing vacuum tanks were modified to contain the magnet and to fit into straight section 26. The magnets were newly designed and constructed. Their design is based on the septa previously developed for the PSB – PS transfer line [2]. The main magnet parameters are presented in table 2.

Table 2: Main parameters of the PS ion injection septum PI.SMH26

Deflection angle	51.5	Mrad
Integrated magnetic field	0.247	T.m
Integrated fringe field	< 1.2	%
Gap height	60.4	Mm
Magnet length	851	Mm
Septum conductor thickness	5	Mm
Number of turns	1	
Peak design current	15.0	kA
Peak design current density in septum conductor	57	A/mm <sup>2</sup>
RMS current	310	A
Half sine pulse width	≈ 3.6	Ms
Magnet inductance	1.7	μH
Magnet resistance	1	mΩ

### Design and Construction

The magnet has been designed with the same physical length as the previous magnet using the same vacuum vessel, making it compatible with the existing remote displacement system and current feedthrough position. Despite the significant increase in cross section of the new magnet compared with the previous magnet it was possible to meet the specified beam acceptance and

remote angular and radial displacements by increasing the flange diameter and openings on the upstream and the downstream side of the vessel. The connection between the coil and the feedthrough has been preserved, eliminating the need for the machining of radioactive components and thereby reducing the overall cost. Experience with the previously built magnets of this type, together with 2D and 3D finite element calculations predicted the magnet's performance, in line with physics requirements [3].

The static magnetic performance of the mechanical geometry was subsequently calculated using a finite element based program called 'FLUX2D' from Cedrat. The calculated 2D gap field uniformity was  $\pm 0.5\%$ . The longitudinal design was determined using the finite element based program 'OPERA3D/TOSCA' from Vector Fields, using a model developed at CERN to simplify the magnet model (see Fig. 4).

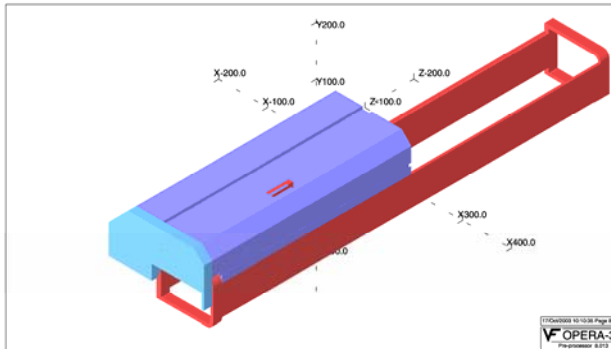

Figure 4: 3D Opera model with simplified coil geometry for the PS ion injection septum.

### Test Phase

Prior to installation, the magnetic performance has been verified. The fringe field is influenced by the eddy currents in the stainless steel reinforcement of the septum conductor. Consequently the fringe field levels are relatively high, i.e. dropping from 1.25 % of the integrated gap field at 5 mm from the septum conductor to 0.9 % at 55 mm. These values are relatively high for an under vacuum septum and are due to eddy currents generated in the stainless steel reinforcement of the septum conductor. The nominal integrated gap field was measured at 14.96 kA.

### Installation

Following the test phase, the magnet was installed in the PS ring (Fig. 5) and pumped under vacuum. The magnet was baked out in the PS, with the magnet at 200 °C for 46 hours. 70 hrs after the bake out was switched off, the vacuum obtained was  $2.4 \times 10^{-8}$  mbar without beam. Several weeks later the vacuum measured in the septum vacuum vessel was  $4.5 \times 10^{-9}$  mbar during the setting up of the PS with protons, but with the septum not pulsing. Until the ion run later this year, the vacuum is will improve further. By using the titanium sublimators pump a vacuum in the  $10^{-10}$  mbar range is expected.

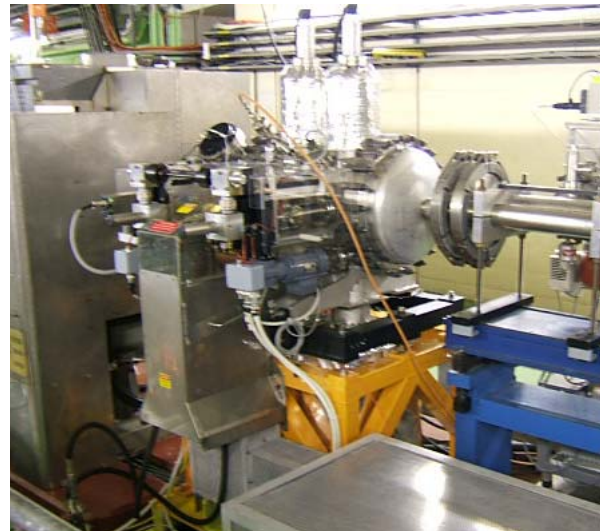

Figure 5: PS ion injection septum PI.SMH26 installed in the ring.

## CONCLUSION

The LEIR extraction septum was installed and operated successfully during the LEIR commissioning phase early in 2006. A spare septum will be constructed during the year. Since the design and construction period of the magnet did not allow for an extended prototype test phase, the spare will incorporate design improvements of the highest stressed components. In particular, the septum conductor insulation will be changed to increase its expected lifetime, while towards the end of 2006 a spare upgraded vacuum chamber will also be constructed with the intention of further increasing its resistance to mechanical stresses.

The PS ion injection septum was constructed, and tested before installation in the PS in February 2006. The reserve septum is still under construction, but is foreseen to be operational before the start of the 2006 PS ion run in autumn.

## ACKNOWLEDGEMENTS

The realisation of these magnets is the collaborative effort of many people from various CERN groups and departments. The authors would like to thank them all for their co-operation.

## REFERENCES

- [1] J. Borburgh, M. Crescenti, M. Hourican, T. Masson, "Design and Construction of the LEIR Extraction Septum", MT19, Genoa, Italy, September 2005.
- [2] J. Borburgh, M. Hourican, M. Thivent, "A New Set of Magnetic Septa in the PS Complex", PAC'99, New York, USA.
- [3] M. Benedikt, P. Collier, V. Mertens, J. Poole, K. Schindl, "LHC Design Report, Volume III, The LHC Injector Chain", CERN-2004-003, Geneva, Switzerland, December 2004, p. 340.