

## 2nd Annual Report

CARE

Coordinated Accelerator Research in Europe

Integrating Activity

implemented as

Integrated Infrastructure Initiative

Contract number: RII3-CT-2003-506395

Project Co-ordinator: Roy ALEKSAN

Project website: <http://care.lal.in2p3.fr/>

Reporting period: from 01/01/2005 to 31/12/2005

Project funded by the European Community  
under the “Structuring the European Research Area” Specific Programme  
Research Infrastructures action

<b>A. ACTIVITY REPORT.....</b>	<b>4</b>
1. PROGRESS REPORT .....	4
1.1 Summary of the activities and major achievements .....	4
1.1.1 Networking Activities.....	4
1.1.2 Joint Research Activities .....	5
1.2 MANAGEMENT ACTIVITY.....	6
1.3 NETWORKING ACTIVITIES (other than Management) .....	7
1.3.1 N1: Electron Linear Accelerator Network (ELAN) .....	7
N1.1 MEETINGS.....	9
N1.2 Publications.....	10
N1.3 Web sites .....	10
N1.4 Activities of ELAN in 2005 .....	10
N1.5 Overall Progress of Work Packages .....	11
N1.6 Significant Achievements.....	12
N1.7 List of all deliverables during the reporting period .....	12
N1.8 List of major meetings organized under ELAN during the reporting period .....	13
1.3.2 N2: Beams in Europe for Neutrino Experiments (BENE) .....	14
N2.1 Meetings.....	15
N2.2 The International Scoping Study.....	17
N2.3 Publications.....	17
N2.4 Web Sites .....	18
N2.5 Activities of BENE in 2005.....	18
N2.6 Overall Progress of Work Packages .....	20
N2.7 Significant Achievements.....	22
N2.8 List of all deliverables during the reporting period .....	22
N2.9 List of major meetings organized under BENE during the reporting period .....	22
1.3.3 N3: High-Energy High-Intensity Hadron Beams (HHH).....	23
N3.1 Overall Network Organisation and Main Activities .....	23
N3.2 Work Package 1: Advancements in Accelerator Magnet Technologies (AMT).....	29
N3.3 Work Package 2: Novel Methods for Accelerator Beam Instrumentation (ABI) .....	32
N3.4 Work Package 3: Accelerator Physics and Synchrotron Design (APD).....	35
N3.5 Significant Achievements.....	39
N3.6 List of all milestones and deliverables (D) during the reporting period .....	39
N3.7 List of major meetings organized under HHH during the reporting period.....	40
1.4 JOINT RESEARCH ACTIVITIES.....	41
1.4.1 JRA1: Superconducting Radio Frequency (SRF).....	41
JRA1.1 Work Package 1: Management and Communication.....	41
JRA1.2 Work Package 2: Improved Standard Cavity Fabrication .....	42
JRA1.3 Work Package 3: Seamless Cavity Production.....	48
JRA1.4 Work Package 4: Thin Film Cavity Production .....	54
JRA1.5 Work Package 5: Surface Preparation.....	66
JRA1.6 Work Package 6: Material Analysis .....	71
JRA1.7 Work Package 7: Couplers.....	77
JRA1.8 Work Package 8: Tuners .....	82
JRA1.9 Work Package 9: Low Level RF (LLRF).....	92
JRA1.10 Work Package 10: Integrated RF tests in a Horizontal Cryostat .....	111
JRA1.11 Work Package 11: Beam Diagnostics.....	113
JRA1.12 Significant Achievements.....	121
JRA1.13 List of all milestones and deliverables (D) during the reporting period .....	122
JRA1.14 List of major meetings organized under SRF during the reporting period .....	124
1.4.2 JRA2: Charge Production with Photo-Injectors (PHIN) .....	125
JRA2.1 Work Package 1: Management and Communication.....	125
JRA2.2 Work Package 2: Charge Production .....	126
JRA2.3 Work Package 3: LASER.....	129
JRA2.4 Work Package 4: RF GUN and Beam Dynamics .....	132
JRA2.5 Significant Achievements.....	137
JRA2.6 List of all milestones and deliverables (D) during the reporting period .....	137
JRA2.7 List of major meetings organized under PHIN during the reporting period .....	137
1.4.3 JRA3: High Intensity Proton Pulsed Injector (HIPPI).....	139
JRA3.1 Work Package 1: Management and Communication.....	139
JRA3.2 Work Package 2: Normal Conducting Accelerating Structures.....	142
JRA3.3 Work Package 3: Superconducting Accelerating Structures .....	154
JRA3.4 Work Package 4: Beam Chopping .....	174
JRA3.5 Work Package 5: Beam Dynamics .....	181
JRA3.6 Significant Achievements.....	186

A. ACTIVITY REPORT

JRA3.7 List of all milestones and deliverables (D) during the reporting period .....	186
JRA3.8 List of major meetings organized under HIPPI during the reporting period .....	187
1.4.4 JRA4: Next European Dipole (NED) .....	188
JRA4.1 Work Package 1: Management and Communication (M&C).....	188
JRA4.2 Work Package 2: Thermal Studies and Quench Protection (TSQP).....	195
JRA4.3 Work Package 3: Conductor Development (CD) .....	199
JRA4.4 Work Package 4: Insulation Development & Implementation (IDI).....	208
JRA4.5 Working Group Magnet Design and Optimisation.....	211
JRA4.6 Significant Achievements.....	214
JRA4.7 List of all milestones and deliverables (D) during the reporting period .....	215
2. LIST OF DELIVERABLES .....	217
3. USE AND DISSEMINATION OF KNOWLEDGE .....	220
ANNEXES .....	223
<b>B. MANAGEMENT REPORT (FINANCIAL INFORMATION).....</b>	<b>225</b>
1. JUSTIFICATION OF THE RESOURCES DEPLOYED.....	225
2. FORMS C - FINANCIAL STATEMENTS.....	259
3. SUMMARY FINANCIAL REPORT.....	306
<b>C. REPORT ON THE DISTRIBUTION OF THE COMMUNITY FINANCIAL CONTRIBUTION. 310</b>	
<b>D. DETAILED IMPLEMENTATION PLAN FOR THE NEXT 18 MONTHS .....</b>	<b>314</b>

## A. ACTIVITY REPORT

### 1. PROGRESS REPORT

#### 1.1 Summary of the activities and major achievements

The CARE project includes three networking activities ELAN, BENE, HHH, and four joint research activities SRF, PHIN, HIPPI and NED. The second year of the project has permitted the following major achievements.

##### 1.1.1 Networking Activities

###### CARE Management Activity

- Edition of the first CARE annual report (April 2005)
- Table of the CARE deliverables posted on the CARE web site (November 2005)
- Organisation of the CARE general meeting CARE05 (CERN-Geneva, November 2005)

###### N1 Electron Linear Accelerator Network (ELAN)

- The organisation of the plenary ELAN meeting at Royal Holloway, London (June) in conjunction with EUROTEV.
- The implication of ELAN in the Global Design Effort (GDE) towards the International Linear Collider ILC. Quantitatively: 4 ELAN conveners belong to the GDE team and 12 workshops related to the GDE were supported by ELAN.
- Approval of the NEST European initiative EUROLEAP coordinated by the ELAN-ANAD work package leader on new techniques of acceleration (December 2005).
- Transfer of knowledge between accelerator experts and the laser/plasma community to design a multi-TeV collider (Paris workshop organized under ELAN)

###### N2 Beams in Europe for Neutrinos Experiment (BENE)

- Organization of the NNN05 (Next Generation of Nucleon Decay and Neutrino Detectors) and Nufact05 International Workshops in Europe.
- Approval of the MERIT high power target and collection experiment at CERN
- Launch of the International Scoping Study on Neutrino Factories & Superbeams.
- The BENE Midterm Interim Scientific Report, contribution to the CERN Council Strategy.

###### N3 High Energy High Intensity Hadron Beams (HHH)

- Two specific CARE-HHH working groups were created in 2005 addressing the issues of the LHC Interaction Regions, and of an upgrade of the GSI and LHC injector complex, aiming at maximizing the integrated luminosity.
- An intense effort was made for the dissemination of information and seven HHH workshops were organized in 2005.
- HHH web repositories for accelerator physics codes and LHC IR upgrade optics solutions were set up.



### 1.1.2 Joint Research Activities

#### JRA1 Superconducting Radio Frequency (SRF)

- The construction of a spinning machine for seamless cavity production is now complete (WP3, INFN-LNL).
- Improved understanding of the “ageing” of electro-polishing mixtures will probably lead to improvements in this important cavity preparation technique. An automated electro-polishing system is now operating at DESY (WP5, CEA and DESY).
- New active tuners have been developed at CEA and INFN-Mi, using piezo-electric cells, which will be ready for tests with cavities early in 2006. The application of a piezo-electric tuner has been demonstrated to reduce Lorentz force de-tuning from 180 Hz to less than 10 Hz on a TTF cavity operating at 20 MV/m (WP8).
- Several advances have been made in Low Level RF development where, to give but one example, optimal controlling routines have been developed to provide RF phase stability of 0.03 degrees and amplitude stability of  $3 \times 10^{-4}$  on a TTF-VUV module (WP9, DESY, TUL and WUT-ISE).
- Both the hardware and software for the beam emittance monitor are now complete ahead of schedule. The monitor has been mounted on the TTF beam-line and is awaiting allocation of beam time for the first tests (WP11, INFN-LNF and INFN-Ro2).

#### JRA2 Charge Production in Photo-Injectors (PHIN)

- CTF3 laser oscillator achieved its specified performances, in particular with respect to amplitude stability and time jitter. This is the first laser in the world with 1.5 GHz pulse rate (CERN).
- Delivery of all the components for the two high power amplifiers of the CTF3 laser (CERN).
- Laser commissioning with DAZZLER pulse shaping. Development of cross correlation diagnostics system for UV square pulse. Laser synchronization with external RF at 0.5ps level (INFN-LNF).
- IR square pulses with space mask (INFN-Mi).
- Delivery of the CTF3 photo injector prototype (CNRS-Orsay).
- Photocathode preparation system assembled and tested. Cathode cooling system delivered and functionality tested (FZR).
- High intensity electron beam from plasma (CNRS-LOA).

#### JRA3 High Intensity Pulsed Proton Injector (HIPPI)

- Definition of an optimized beam dynamics and RF structure layout for a Drift Tube Linac tank from 3 to 10 MeV beam energy. This layout will be used for the construction of a high-power prototype.
- Successful cool-down and tests of superconducting spoke cavities at 700 MHz (FZJ) and 352 MHz (CNRS-Orsay).

#### JRA4 Next European Dipole (NED)

- Manufacturing and reception tests of double-bath, HeII cryostat for heat transfer measurements.
- Detailed computations of thermo-electrical behaviour of NED-like magnets during a quench.
- Assembly of first round of billets for NED conductor production at Alstom/MSA and SMI.

- Identification of a polyimide-sized, glass fiber tape candidate for conventional conductor insulation.
- Iterated design of an 88 mm aperture 15 T dipole magnet (NED Reference Design V2).

## 1.2 MANAGEMENT ACTIVITY

- The CARE Web site has migrated to <http://care.lal.in2p3.fr/> and it has been regularly updated (CNRS-Orsay).
- The official table of the CARE deliverables has been constructed and posted on the CARE Web site at <http://care.lal.in2p3.fr/Deliverables> . This table provides links to the existing deliverables. For the Networking Activities, this table will allow the addition of new deliverables to adapt to the latest developments over the contract period.
- Migration of the CARE Publication Database on a new server for better maintenance <http://www-dapnia.cea.fr/Documentation/Care/index.php> (CEA).
- Release of two intermediate activity reports per activities, available from the CARE web site <http://care.lal.in2p3.fr/Quarterly/NA/> and <http://care.lal.in2p3.fr/Quarterly/JRA/> .
- The following table lists all the management meetings as well as the general annual meeting CARE 05 organised by the management team.

<b>Date</b>	<b>Title/subject of meeting</b>	<b>Location</b>	<b>Number of attendees</b>	<b>Website address</b>
5-6 April 2005	CARE Joint Steering Committee and Dissemination Board	CERN (Geneva)	17	<a href="http://care.lal.in2p3.fr/CAREmeetings/Management/Steering/Schedule/">http://care.lal.in2p3.fr/CAREmeetings/Management/Steering/Schedule/</a>
5-6 Sept. 2005	CARE Joint Steering Committee and Dissemination Board	Paris	12	<a href="http://care.lal.in2p3.fr/CAREmeetings/Management/Steering/Schedule/">http://care.lal.in2p3.fr/CAREmeetings/Management/Steering/Schedule/</a>
23-25 Nov. 2005	General meeting CARE'05	CERN (Geneva)	195	<a href="http://hep-lab.web.cern.ch/HEP-lab/CARE05/JRANA.htm">http://hep-lab.web.cern.ch/HEP-lab/CARE05/JRANA.htm</a>
25 Nov. 2005	CARE Governing Board Meeting	CERN (Geneva))	17	<a href="http://care.lal.in2p3.fr/CAREmeetings/Management/Governing/Schedule/">http://care.lal.in2p3.fr/CAREmeetings/Management/Governing/Schedule/</a>
25 Nov. 2005	CARE Joint Steering Committee and Dissemination Board	CERN (Geneva))	17	<a href="http://care.lal.in2p3.fr/CAREmeetings/Management/Steering/Schedule/">http://care.lal.in2p3.fr/CAREmeetings/Management/Steering/Schedule/</a>

### 1.3 NETWORKING ACTIVITIES (other than Management)

#### 1.3.1 N1: Electron Linear Accelerator Network (ELAN)

ELAN is the CARE network for Electron Linear Accelerators. It comprises 11 countries plus CERN. The list of participants and their implication in the ELAN Work Packages (C: Coordination, X: Participation) is given in the table below. The overall management is done by CNRS-Orsay and CERN.

Number	Participant	WP1 LTECNC	WP2 LTECSC	WP3 BDYN	WP4 INSTR	WP5 ANAD
1	CEA		X	X	X	
3	CNRS	X	X	X	X	C
	CNRS-Orsay		X	X		
	CNRS-CPHT					X
	CNRS-LULI					X
	CNRS-LAPP	X			X	
	CNRS-LOA	X			X	X
	CNRS-LPGP					C
	CNRS-LPCO	X				
6	DESY		C	X	X	
7	FZJ				X	
9	FZR	X	X		X	
10	INFN	X	X		X	
	INFN-LNF	X			X	
	INFN-LNL		X			
	INFN-Mi		X			
	INFN-Na		X			
	INFN-Ro2		X			
11	TEU				X	
12	TUL		X			
13	IPJ		X			
14	WUT-ISE		X			
16	CSIC		X	X		
	CIEMAT		X			
	LEII		X			
17	CERN	C		C	X	
19	PSI				X	
20	CCLRC	X	X	X	X	X
21	ICL			X	X	X
22	UMA			X	C	

## ELAN in 2005

This period has been marked by the start of an international structure, the GDE, aimed at producing a design and cost of the future International Linear Collider ILC. This body comprises 49 members active on all fields relevant to ILC, 21 coming from Europe, most of them belonging to ELAN network. The GDE also intends to coordinate R&D efforts towards this goal. ELAN, whose activities are closely related to these objectives, has therefore supported 12 workshops on key issues for ILC, in particular the London meeting directly organized by ELAN which will be described in more details below.

A two week worldwide workshop, with over 600 participants, was held in Snowmass (Colorado) this summer to identify the key decisions for the design of an ILC. This workshop was prepared, at the European level, by 7 workshops supported by ELAN as shown pictorially below.

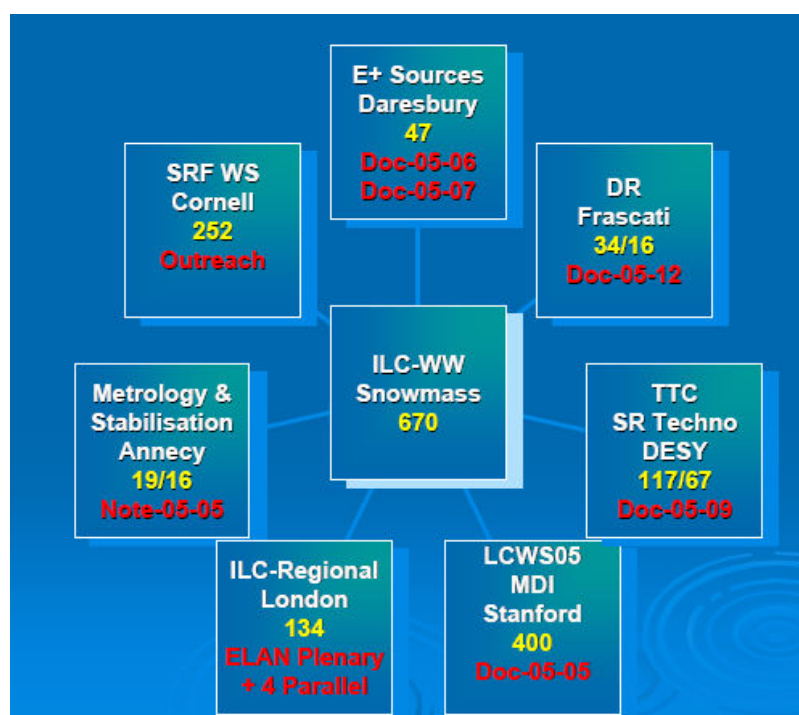


Figure NA1.1: Workshops supported by ELAN in view of the GDE meeting of Snowmass. In yellow are the number of participants (/from ELAN), in red the reference in the CARE-ELAN Document database.

At the end 2005, four new institutes have been associated to CARE via the ELAN Network. They are listed in the table below.

Organisation (name, city, country)	Short name	Associated to
Center for the Advancement of Natural Discoveries using Light Emission, Yerevan, Armenia	CANDLE	CERN
Technion – Israel Institute of Technology, Tel-Aviv, Israel	Technion-IIT	CERN
Stanford Linear Accelerator Center, Stanford, USA	SLAC	CERN
Krakov University of Technology, (Institute of Applied Mechanics), Krakow, Poland	CUT	CERN

## **ELAN Steering Committee**

An ELAN steering committee took place during the CARE annual meeting at CERN. Concerning the activity in 2006, a proposal to support a workshop at CERN on the Compton scheme for positron production was discussed and approved. It was also decided to hold the ELAN mid-term meeting together with EUROTeV mid 2006.

In preparation for the governing board, the ELAN 2005 budget was discussed and it was noticed that contrary to year 2004 several contractors were overspending with respect to provisions. It was recalled that initial plans were that contractors would provide the missing resources when necessary.

Deliverables of ELAN in 2005 were analyzed. It was agreed that for the 3 working packages dealing with ILC matters (SCRF, Beam dynamics and Instrumentation) deliverables tend to coincide with GDE activities which are documented in GDE web pages. It was however agreed that ELAN web pages for these packages should contain commented references to the relevant GDE web pages.

## **N1.1 MEETINGS**

### **The London Meeting**

This meeting was jointly organized with the Design Study EUROTeV. It started with a plenary session organized by ELAN which presented the conclusions from relevant workshops with important ELAN participation. The talks were:

- Issues related to normal conducting linear colliders, by G.Guignard (CERN)
- Recent developments on SRF Techno in view of Snowmass, by L.Lilje (DESY)
- New techniques of acceleration , by B.Cros (CNRS-LOA)
- The Mini-Workshop on **WIGGLER** optimization for **Emittance** control, by M.E. Biagini (INFN-LNF).

ELAN has also organized a session to discuss the involvement of the 3 regions in the GDE:

- ATF2 (Japan) – Overview, by K. Yokoya
- European Issues, by B. Foster
- American Issues, by G. Dugan

There were three parallel sessions on ELAN activities on Beam Dynamics, Instrumentation and Superconducting Radio-Frequency Technology. Two interface sessions took place with EUROTeV, UK-BDIR (the UK initiative on ILC) and WG4 (Beam Delivery System) from the GDE.

### **The workshop on Metrology and Stabilization for Linear Colliders**

This workshop defined the major lines of activities to be pursued: modelling and simulations, development of small sensors and of actuators, contact the designers of the final-focus quadrupoles, link the development to possible tests and develop second-generation positioning devices.

### **The workshop on Wiggler Optimization for Emittance Control**

This workshop treated the wiggler technology and parameters, the existing experimental results, modelling of wiggler fields, applications to ILC and CLIC and beam dynamics studies.

### **The workshop on Positron Sources**

This workshop discussed all possible positron source options to be possibly considered for ILC and CLIC and assessed the R&D issues to be addressed. In this context, a new idea came out to use an autonomous low-energy electron beam with Compton back-scattering on powerful lasers.

### **The High Energy Electron Accelerator Using Plasmas (HEEAUP 2005) Workshop**

A workshop on new techniques of acceleration, HEEAUP 2005, took place in Paris in June 2005. B. Cros, the ELAN-ANAD working group convener, was head of the organizing committee. The goal was to discuss the implementation of ultra-high gradient acceleration techniques using plasmas for the development of high energy particle accelerators. There was also an important participation of accelerator specialists, a natural synergy favored by the ELAN framework.

### **CARE Annual Meeting at CERN**

During this meeting there were 2 parallel sessions. One of them dealt with beam dynamics and instrumentation the other one was on CLIC/CTF activities.

Session on BDYN/INSTR:

- Summary of the Working Group 1 of the 2<sup>nd</sup> ILC Workshop in Snowmass D.Schulte. CERN
- Summary of the Global Group 2 of the 2<sup>nd</sup> ILC Workshop in Snowmass. H.Braun. CERN
- Status of the Beam Delivery System R&D in the UK. P.Burrows UCL, London
- Simulation of Emittance and Luminosity Tuning. P.Eliasson, CERN
- Beam-beam Studies. C.Rimbault CNRS-Orsay

Session on LTECNC:

- Status report on active stabilisation of a linear collider final focus quadrupole mock-up J.Lottin, ESIA
- Progress made about the CLIC accelerating Structures, W.Wuensch, CERN.
- Status of CTF3 and of CTF3 collaboration, G.Geschonke, CERN.
- Recent developments on the damping rings and their wigglers. S.Guiducci, INFN-LNF.
- Summary of the ILC workshops on positron sources, L.Rinolfi, CERN.

### **TTC and CTF Collaboration meetings**

ELAN participants have also been involved in the TESLA Technology Collaboration and the CLIC Test Facility collaboration meetings which are the back-bone of the ELAN activities, both for the ILC preparation and for the development of normal conducting high-gradient linear colliders. These meetings discuss and coordinate the progress, test results and future plans of the existing TTF and CTF infrastructures

### **N1.2 Publications**

The list of ELAN-Documents can be found in the ELAN database:

<http://esgard.lal.in2p3.fr/Project/Activities/Current/Networking/N2/ELAN/Documents/>

### **N1.3 Web sites**

The central ELAN web page <http://care.lal.in2p3.fr/Networking/N2/ELAN/> and the web pages of the 5 work packages have been regularly updated.

### **N1.4 Activities of ELAN in 2005**

#### **Specific contributions on the ILC project**

R&D on cavities, a key issue for the performances and costing of ILC, has been discussed in many workshops encouraged by ELAN. The LTECSC working group has produced the following contribution to the project:

- Summary Talk London (L. Lilje, DESY)  
[https://ilcsupport.desy.de/cdsagenda/askArchive.php?base=agenda&categ=a0522&id=a0522s53t3/transparencies/Summary\\_of\\_SRF\\_WG\\_LL\\_.pdf](https://ilcsupport.desy.de/cdsagenda/askArchive.php?base=agenda&categ=a0522&id=a0522s53t3/transparencies/Summary_of_SRF_WG_LL_.pdf)
- BCD Proposal for Cavity preparation (L. Lilje, DESY)

[http://alcp2005.colorado.edu:8080/alcp2005/program/accelerator/WG5/helen\\_edwards20050821164419.ppt](http://alcp2005.colorado.edu:8080/alcp2005/program/accelerator/WG5/helen_edwards20050821164419.ppt)

[http://alcp2005.colorado.edu:8080/alcp2005/program/accelerator/WG5/helen\\_edwards20050819140512.ppt](http://alcp2005.colorado.edu:8080/alcp2005/program/accelerator/WG5/helen_edwards20050819140512.ppt)

- Highlight talk at the CARE05 annual meeting at CERN (B. Visentin, CEA)

<http://indico.cern.ch/getFile.py/access?contribId=7&sessionId=1&resId=1&materialId=slides&confId=a059>

### Outreach and Tutorials

In several occasions, ELAN has helped in organizing lectures on superconductivity intended for a wide audience. Examples of these are:

- Snowmass SRF Cavity tutorial (L. Lilje, DESY)

[http://alcp2005.colorado.edu:8080/alcp2005/program/ENO/Superconductingcavitiestutorial\\_new.pdf](http://alcp2005.colorado.edu:8080/alcp2005/program/ENO/Superconductingcavitiestutorial_new.pdf)

- SRF Tutorials at the SRF 2005 Workshop (D. Reschke, DESY):

[http://www.lns.cornell.edu/public/SRF2005/talks/sunday/SuP03\\_talk\\_srf2005.pdf](http://www.lns.cornell.edu/public/SRF2005/talks/sunday/SuP03_talk_srf2005.pdf)

### The NEST project EUROLEAP

The ANAD pork package convener has coordinated EUROLEAP, a NEST project meant to achieve a laser-plasma accelerator to test the issues related to the control of the properties of an electron beam accelerated to a GeV in a plasma wave. The EUROLEAP proposal was submitted on April 13, 2005 and approved in January 2006.

### N1.5 Overall Progress of Work Packages

The five following tables highlight the progress of work planned in the year 2005 for each work package by listing the lowest level subtasks of the ELAN detailed implementation plan. No major deviations are reported.

#### Work Package 1: Normal Conducting Linac Technology (LTECNC)

	Title	Original end date	Estimated Status	Revised end date
<b>WP1</b>	<b>Normal Conducting Technology</b>			
1.3	Proceedings CTF3 workshop	Dec. 2005	ELAN-Doc expected	
1.7	Workshop report on topical activity status	Jul. 2005	CARE-Note-05-05	
1.10	Complementing DB and documentation	Sept. 2005	100% Web site	
1.13	Report on status of sources	Jul. 2005	ELAN-Doc-05-19	End of December

#### Work Package 2: Super Conducting Linac Technology (LTECSC)

	Title	Original end date	Estimated Status	Revised end date
<b>WP2</b>	<b>Superconducting Linac Technology</b>			
2.7	TTF Workshop Develop cavity reliability road map	Oct. 2005	ELAN-Doc expected	End of December
2.11	Evaluation of quality control and cleaning methods	Jun 2005	ELAN-Doc-05-09	

#### Work Package 3: Beam Dynamics (BDYN)

	Title	Original end date	Estimated Status	Revised end date
<b>WP3</b>	<b>Beam Dynamics</b>			
3.4	Summary Report	May 2005	ELAN-Doc-05-16	

## Work Package 4: Instrumentation (INSTR)

	Title	Original end date	Estimated Status	Revised end date
<b>WP4</b>	<b>Instrumentation</b>			
4.2	Web site	Jun. 2005	Done	

## Work Package 5: Advanced and Novel Accelerator Development (ANAD)

	Title	Original end date	Estimated Status	Revised end date
<b>WP5</b>	<b>Advanced and Novel Accelerator Development</b>			
5.13	Workshop on Electron Beam focusing	Aug. 2005	Abandoned	
5.15	Meeting	July 2005	ELAN-Doc-05-10	
5.16	RTN Proposal	Sept. 2005	100% ELAN-Doc expected	

**N1.6 Significant Achievements**

- The organisation of the plenary ELAN meeting at Royal Holloway, London (June) in conjunction with EUROTEV.
- The implication of ELAN in the Global Design Effort (GDE) towards the International Linear Collider ILC. Quantitatively: 4 ELAN conveners belong to the GDE team and 12 workshops related to the GDE were supported by ELAN.
- The involvement of ELAN in activities related to normal conducting linear colliders, linac beam dynamics and new initiatives in the acceleration techniques and light sources. Quantitatively: 1 general ELAN meeting and 4 workshops specialized on these items
- The ELAN network work package leader on new technique of acceleration has successfully coordinated the NEST European initiative known as EUROLEAP (approved end of December 2005).
- Transfer of knowledge between accelerator experts and the laser/plasma community to design a multi-TeV collider (Paris workshop organized under ELAN)
- The release of the publication of 20 documents in the ELAN web-base which describes in detail some contributions achieved under ELAN.
- The recurrent participation to the TESLA and CLIC collaborations for what concerns the R&D on Linac technologies.

**N1.7 List of all deliverables during the reporting period**

N°	Deliverable Name	Deliverable Type	Work Package	Lead Contractor	Planned (in months)	Achieved (in months)
1	Work plan and documentation data base	<a href="#">Data base</a>	WP1	CERN	24	22
2	Data base on SRF documents	<a href="#">Data base</a>	WP2	DESY	24	24, 70% final



**N1.8 List of major meetings organized under ELAN during the reporting period**

<b>Date</b>	<b>Title/subject of meeting /workshop</b>	<b>Location</b>	<b>Number of attendees</b>	<b>Website address</b>
8-10 June 2005	International Workshop on High Energy Electron Acceleration Using Plasmas, HEEAUP 2005	Paris (France)	73	<a href="http://polywww.in2p3.fr/actualites/congres/heeaup2005/">http://polywww.in2p3.fr/actualites/congres/heeaup2005/</a>
20-23 June 2005	First ELAN Meeting / ILC European Regional Meeting	London (UK)	134	<a href="http://www.pp.rhul.ac.uk/workshop/">http://www.pp.rhul.ac.uk/workshop/</a>
23-25 Nov. 2005	Second ELAN meeting / CARE05 Annual Meeting	CERN (Switzerland)	195	<a href="http://hep-lab.web.cern.ch/HEP-lab/CARE05/JRANA.htm">http://hep-lab.web.cern.ch/HEP-lab/CARE05/JRANA.htm</a>
29-30 Nov. 2005	CTF3 Collaboration Meeting	CERN (Switzerland)	??	<a href="http://ctf3.home.cern.ch/ctf3/New_collab_meet.htm">http://ctf3.home.cern.ch/ctf3/New_collab_meet.htm</a>
5-7 Dec. 2005	TESLA Technology Collaboration Meeting	Frascati (Italy)	175	<a href="http://www.lnf.infn.it/conference/ilc05/">http://www.lnf.infn.it/conference/ilc05/</a>

### 1.3.2 N2: Beams in Europe for Neutrino Experiments (BENE)

BENE is the CARE network for Beams for European Neutrino Experiments. It comprises 13 countries plus CERN. The table of the participants and their implication in the BENE Work Packages is given in the table below. The overall management is done by INFN-Na. A new Deputy Coordinator is being searched. .

Participant number	Participant	PHYSICS	DRIVER	TARGET	COLLECTOR	NOVEL NEUTRINO BEAMS
<b>1</b>	<b>CEA</b>	X	<b>C</b>	X	X	<b>C</b>
<b>2</b>	<b>UCLN</b>	X				X
<b>3</b>	<b>CNRS</b>	X			<b>C</b>	X
	CNRS-Orsay	X			<b>C</b>	X
	CNRS-LPNHE	X			X	
	CNRS-CENBG	X				
	CNRS-IPNL	X			X	
	CNRS-LPSC					X
	CNRS-IReS	X			X	
<b>4</b>	<b>GSI</b>					X
<b>7</b>	<b>FZJ</b>		X	X		
<b>8</b>	<b>TUM</b>	X				X
<b>10</b>	<b>INFN</b>	<b>C</b>	X	X	X	X
	INFN-LNF	X				X
	INFN-Ba	X				X
	INFN-Ge					X
	INFN-GS	X				
	INFN-LNL	X	X			X
	INFN-Mi	X				X
	INFN-Na	X				X
	INFN-Pa	<b>C</b>				X
	INFN-Pi	X				
	INFN-Tr	X				X
	INFN-Ro3	X				X
	INFN-To	X				
<b>16</b>	<b>CSIC</b>	X				
	UBa	X				
	IFIC	X				
	UAM	X				
<b>17</b>	<b>CERN</b>	X	X	X	X	<b>C</b>
<b>18</b>	<b>UNI-GE</b>	X		X	X	X
<b>19</b>	<b>PSI</b>			X		
<b>20</b>	<b>CCLCR</b>	X	X	<b>C</b>	X	<b>C</b>
	CCLRC-RAL	X	X	<b>C</b>	X	<b>C</b>
<b>21</b>	<b>ICL</b>	X		X		X

The mandate of the BENE Network is to promote clear awareness in our particle physics community of a) the physics interest of superior accelerator neutrino beams (superbeams, betabeams, neutrino factories), b) the promising on-going developments of accelerator technology that will make them possible, c) the opportunities that exist to plan, fund and realize, on a realistic time scale, a much enhanced European accelerator neutrino complex.

During 2005, the BENE Network has:

1) significantly tightened its international role and connection, manifestly essential for any new EU accelerator neutrino complex to be conceivable. We have attracted and welcome in Europe, in two workshops, held in April (NNN05) and in June (NuFact05), the full international community working toward superior accelerator neutrino beams

2) launched the next natural step in our feasibility study and R&D program, a one year International Scoping Study (ISS) on Neutrino Factories and Superbeams, to be completed by August 2006. The study has gained its first momentum at its first working international meeting at CERN Sep 22-24 and is preparing its next meeting in Japan in January. This is a decisive step in the preparation of the Proposal for a complete FP7 Design Study, see below.

3) achieved its Midterm Scientific Report, being published as a CERN Yellow Report, based on the state-of-the-art summaries reports presented at NuFact05 & NNN05. It was presented to CARE05 in November. It is being submitted to the CERN Council Strategy Group and to ECFA. It summarizes the state of advancement of our initiative, reviewing progress and proposing a preliminary road map towards a superior European accelerator neutrino facility to be built in the coming decade.

During 2006, BENE plans will be to strongly push the ISS and assemble the continental collaboration necessary to propose and conduct the FP7 Design Study.

The main appointments in 2006 are the 2<sup>nd</sup> ISS meeting at KEK Jan 23-25, the first BENE week in the UK in conjunction with the 3<sup>rd</sup> ISS meeting Apr 24-29, the NuFact06 Workshop in Irvine where the ISS will give its conclusions and the traditional BENE06 meeting in conjunction with CARE06. An additional shorter BENE meeting may take place at CERN in September.

## N2.1 Meetings

The major events organized or co-organized by BENE in 2005 were:

1) The **1<sup>st</sup> BENE Week Mar 16-18**. This was the regular week of meetings of BENE related work packages, study groups and R&D projects. We had first a parallel meetings of the Target and Collector WP jointly, then a one day plenary session of all accelerator WP together, where the themes of each of them (DRIVER, TARGET, COLLECTOR, MUFROnt, MUEND and BETABEAM) and those specific of the HARP, MICE and MERIT R&D experiments were each covered by a few hours of presentations and discussion. A plenary session was devoted then to discuss the proposal of launching a Scoping Study. After half a day of PHYSICS plenary session, discussion on ISS was resumed and the agenda of BENE in 2005 was finalized.

2) The **NNN05 Workshop on Next Nucleon decay & Neutrino** detector held in Aussois, France, Apr 7-9. This is the 4<sup>th</sup> edition of this international Workshop, organized now in Europe for the second consecutive time with major contributions from the PHYSICS, DRIVER and BETABEAM working groups in BENE. The concept of a large Megaton water detector has emerged independently in the 3 regions, under the name of Hyper-Kamiokande in Japan, of UNO in the USA, MEMPHYS in the Western Alps in Europe, where the Li-Argon option is also well alive. The three designs have much in common, the collaborations have significant overlap and work in very close cooperation, with the aim of realizing commonly one such detector in the region that will offer the best and earliest opportunity. Cooperation ties were further strengthened in Aussois.

3) a pre-meeting in London, May 6-7, of the International Scoping Study. This came after thorough discussion at the BENE Week in March, where it was decided, in particular, that the Study should include both Neutrino Factory and Superbeam. In London, it was decided there that the Study would be organized jointly by the Neutrino Factory and Muon collider collaboration in the US, the Japan Neutrino Factory collaboration and the ECFA/BENE Network for future neutrino beams in Europe, where it would be hosted at CCRLC laboratories by the UK neutrino factory collaboration that has promoted it first. An important contribution from India is also foreseen. The coordinators of these 4 collaborations were given mandate to

make a proposal for the leadership of the Study. The preliminary Study Plan, with three study-groups (Physics, Accelerator and Detectors), was approved.

4) The **NuFact05 International Workshop**, the 7<sup>th</sup> International Workshop on Neutrino Factories & Superbeams, held in Frascati, Jun 21-26. This is the yearly international forum of the above mentioned regional communities and has grown remarkably in importance over the years. We were very proud to host it in Europe for the 3<sup>rd</sup> time and the BENE coordinator chaired the organization. It replaced this year the traditional ECFA/BENE Summer Week, enlarging its scope to a full international review of the status of the field, physics, accelerators, detectors, including betabeams. Its last day was devoted to a final discussion of the ISS that was formally launched there on the morning of June 26. It was decided also that the ISS should last one year and should be concluded at NuFact06 (that will notably change its name to 8<sup>th</sup> International Workshop on Neutrino Factories, Superbeams & Betabeams) to be held in Irvine, Aug 24-30, 2006.

The NuFact Workshop has truly become the yearly meeting of a world-wide collaboration and its importance can also be judged from the satellite events that accompany it.

In 2002, the EU component (not yet known as BENE) first proposed and organized a NuFact International Summer School in the UK. After that first school, we had one in the USA in 2003, one in Japan in 2004 and this year the 4<sup>th</sup> **NuFact05 International Summer School on Neutrino Factories & Superbeams** was organized by BENE in Italy, in the island of Capri from June 11 to June 20. 22 students, mostly but not all from Europe attended it. The aim of the school is to provide young particle physicists with an introduction to both particle and accelerator physics aspects of conventional and novel neutrino beams. The long-term goal of this series is to lay the foundation for a large international group of scientists with the diverse skills essential to secure the future of accelerator neutrino experiments. An essential task indeed, for BENE.

5) The first working meeting at CERN Sep 22-24 of the International Scoping Study (ISS) on Neutrino Factories and Superbeams. It was a good success with over 90 people registering, despite the short notice, with parallel group meetings of the three working groups, accelerator, detector and physics, and joint plenary meetings. A work/wish list was drafted for the outcome of the year's investigations. Details can be found on the transparencies, available from the website, <http://hepunx.rl.ac.uk/uknf/wp4/scoping/>.

6) The 3<sup>rd</sup> **BENE Week Nov 22-25** that was, according to tradition, the BENE05 last meeting of the year, within the CARE05 event, where serious discussions and the assembly of a continental collaboration towards an FP7 Design Study have resumed.

At the WP level, the betabeam WP held a joint meeting BENE/Eurisol meeting at RAL 17-18 January, for the start up of the design study. <http://beta-beam.web.cern.ch/beta-beam/Meetings/RAL05/RAL05-presentations.htm>

Satellite meetings of on-going R&D experiments carried out in world wide collaborations where also held. Among them, most important, the [12<sup>th</sup> and 13<sup>th</sup> Collaboration meeting of MICE](#), the Muon Ionisation Cooling Experiment, respectively June 27-29 in Frascati and Oct 21-24 at RAL and a [Collaboration Meeting](#) of the MERIT Target Test Area Experiment in June at CERN. BENE forces are involved deeply in these international efforts as well as in EMMA (the proto collaboration for electron model of non scaling FFAG), mention participation to FFAG-2005, at Fermilab in April, and FFAG05, at KURRI institute in December in Japan.

In addition, BENE has been present to all major neutrino events in the year. In 2005 we will mention only two most important and representative events, the International Neutrino Workshop WIN05 early in June in Delphi and the EPS HEP Conference late in July in Lisbon,

all attended by a significant BENE delegation with speakers in several sessions and/or panel discussions.

BENE has also made reports at regular ECFA meetings in the year. It also reports periodically to the Chairs of the CERN scientific committees (SPSC, SPC) and to the CERN Directorate.

## **N2.2 The International Scoping Study**

Among the main concern of BENE has always been the promotion of a European Design Study (DS) of a Neutrino Factory & Superbeam complex which we envisage to happen also within the broader international context of a World Design Study (WDS). As next call will only be within FP7, BENE has welcomed the CCLRC proposal of a preliminary Scoping Study as a preparatory step in that direction.

After the meeting in London in May, the coordinator of BENE has participated to discussions with the representatives of the US-MC (S. Geer), NuFact-J (Y. Kuno) and UKNF (K. Peach) collaborations. These resulted in a common proposal for the membership of the ISS Program Committee. Reflecting the Study Plan, after approval at NuFact05, this consists of Yori Nagashima (Physics Group), Mike Zisman (Accelerator Group) Alain Blondel (Detector Group). Overall leader is Peter Dornan.

The first meeting of the ISS at CERN defined in depth the task of the 3 study groups which will be

- Physics: study of the reach of future accelerator neutrino beams. Neutrino factories and superbeams will be compared to each other and to neutrino betabeams.
- Accelerator: study of the crucial issues in the sector: proton drivers, target and collection systems (common to Factories and Superbeams) and ionization cooling, acceleration and storage of muons (specific of Factories).
- Detectors: study of the outstanding issues involved in the realization of neutrino detectors of adequate mass and performance for all the three beam options.

Emphasis will be on the identification of the crucial R&D areas in all sectors above, that the Design Study will have later to tackle in depth. The only subject left out of the ISS will be the accelerator aspects of Betabeam that are already covered by a DS.

BENE is now preparing its contributions to the next meeting of the ISS that NuFact-J will organize at KEK in January.

After the completion of the ISS in August 2006, BENE will proceed to prepare the application for a FP7 DS, presumably for spring 2007. A major aspect of the ISS will be the assembly of a large and solid collaboration of laboratory and university teams supported by all the European agencies willing to contribute funds and human resources to the DS. These teams will apply together for EC co-financing of the DS. A first discussion took place at the BENE05 meeting in November.

## **N2.3 Publications**

An overview of BENE documents and publications can be found in:

<http://bene.web.cern.ch/bene/publications/>.

From there one can link to the documents created by each work package. They are structured in the same way as it is proposed for the general CARE publication policy, i.e. CARE Note, Report, Conf, Pub or Document.

Regular update of the database of publications by the work package convenors and the BENE deputy coordinator has been somewhat hindered by the resignation of E.Gschwendtner, unable to continue as deputy. It will now be resuming in earnest.

## N2.4 Web Sites

The BENE Main Web Page has been improved and refurbished at <http://bene.web.cern.ch/bene/>. It displays the general plan of BENE activities for about 1 year ahead. Basic information is kept up to date. BENE federates several pre-existing working groups and relies on their several pre-existing Web sites:

<http://muonstoragerings.web.cern.ch/muonstoragerings/Welcome.html>

<http://nfwg.home.cern.ch/nfwg/nufactwg/nufactwg.html>

<http://beta-beam.web.cern.ch/beta-beam/>

The process of re-organization into a unitary site, in tune with the BENE federative process, continues. In each BENE WP Web page, the fraction of the material relevant to the scope of WP is being reorganized in a coherent set of links.

A Mailing List of members, [bene@cern.ch](mailto:bene@cern.ch), is operational. In addition there exist mailing lists of each work packages. ([hep-mgt-betabeam@cern.ch](mailto:hep-mgt-betabeam@cern.ch), [hep-mgt-bene-collector@cern.ch](mailto:hep-mgt-bene-collector@cern.ch), [hep-mgt-bene-drivers@cern.ch](mailto:hep-mgt-bene-drivers@cern.ch), [hep-mgt-bene-muend@cern.ch](mailto:hep-mgt-bene-muend@cern.ch), [hep-mgt-bene-mufront@cern.ch](mailto:hep-mgt-bene-mufront@cern.ch), [hep-mgt-bene-physics@cern.ch](mailto:hep-mgt-bene-physics@cern.ch), [hep-mgt-bene-target@cern.ch](mailto:hep-mgt-bene-target@cern.ch) ). Other lists of more loosely connected colleagues are also maintained.

## N2.5 Activities of BENE in 2005

BENE's further acceleration of initiative in 2005 is driven by the work of its Steering Committee that has created the necessary networking tools for this and organized the main meetings and the other events. Regular phone-conferences are the main tool of coordination in the interval between meetings.

The BENE SG tried first to tackle the cancellation of further FP6 calls for DS by preparing an application for a Neutrino I3 that would associate to BENE a few indispensable JRA's. Although much work went into it, we failed to match the very tight application deadline. Luckily, discussion and preparation of the ISS started immediately after and greatly benefited of this effort.

The following text and five tables highlight the progress of work planned for the year 2005 for each work package by listing the lowest level subtasks of the BENE detailed implementation plan. No major deviations are reported, with one notable exception in the driver sector (see below).

All WPs had regular phone-meetings over the year.

**WP1 (PHYSICS)** progressed greatly in completing the present round of preliminary assessments of the physics reach of the different beam and detector options. This is best documented in the material of the NuFact05 Workshop and in the Physics chapter of the Midterm Report. As stated above, both a Neutrino Factory with a large magnetic detector and a Betabeam/Superbeam aiming at a very large non magnetic detector emerge as powerful tools for definitive neutrino oscillation studies. The comparison of these and other emerging options is far from being concluded and a systematic and coherent re-visitation will be the task of the Design Study.

**WP2 (DRIVER)** has continued its comparative study of M-Watt proton driver designs. In particular, it stimulated the new CDR, in preparation at CERN, of a SC proton linac (SPL) of higher energy (3.5 GeV). It is also looking carefully at the Fermilab option of a still higher energy linac (8 GeV). It was less effective, so far, in stimulating more systematic studies of the Rapid Cycling Synchrotron option, where only slower efforts are being deployed by European (and non- European) labs and funding agencies. Finally, it is starting looking into the exciting recent idea of using Fixed Field Alternating Gradient (FFAG) machines also as

MWatt p-drivers. It is also clear that the CERN PAF and POFPA task forces will bring this debate out to a much larger forum (and longer time scale). The discussion and comparison of these options is thus being enlarged in consultations with other communities of potential users of the proton driver. The WP will closely follow the works of CERN PAF task force as the choice of the appropriate proton driver is a corner stone of the future of particle physics in Europe.

Two topics of interest of this WP, namely:

- the prospects for intense H- sources and high power injectors
- the HIPPI results on fast choppers and accelerating structure

are closely followed by the WP and will continue to be in the second part of BENE.

**WP3 (TARGET)** has progressed in the comparative studies of different target options: Mercury jets or solid metal. Its major achievement was the approval, in April 2005, of an experiment testing exactly the response of the most likely super-beam and neutrino factory target (liquid mercury jet) and collection system (solenoid) to the energy deposition density typical of the single proton shot produced by a future multi M-Watt driver. The proposal was approved, under the name of MERIT, to run in the n-TOF line at the CERN PS in 2007, funded and manned by an international collaboration with large US and Japanese contributions.

The problem of shock in solid tantalum is being investigated by the UK group at RAL. The construction of the experiment in the UK to measure mechanical thermal shock characteristics (to evaluate the constitutive equations) of tantalum at high temperatures has been completed. A high current pulse has been passed through a thin tantalum wire to obtain the desired energy density. The motion of the wire will be studied using a VISAR. Modelling studies of the thermal shock in tantalum at 2300 K are also well under way with the use of the commercial package LS-DYNA. It has been suggested that by having a large number of beam micro-pulses in the 1-2  $\mu$ s long macro-pulse (at 50 Hz) the thermal shock will be much reduced. The modelling shows this to be true.

One of the responsibilities of BENE is to decide which of the options is best suited to the neutrino factory. Until the tests are completed it will not be possible to rule out either as unsuitable. However, there is a good chance that both will be found to be acceptable solutions, in which case other criteria, such as safety, may be deciding issues.

Regular meetings of the target group have been held in conjunction with the ENG meetings. The second High Power Target Workshop was held in Oak Ridge in October 2005. Members of BENE are involved with the organisation of these workshops. The target website has been established at RAL - <http://hepunx.rl.ac.uk/uknf/wp3/>.

**WP4 (COLLECTOR)** has known some fluctuations. Pre BENE work had produced an initial design of a collection system based on a magnetic horn, a horn prototype optimized for a Neutrino Factory, and a series of feasibility tests. The BENE WP was centred on IN2P3-Orsay laboratory that did a redesign to fulfil the super-beam requirements. After this, however, LAL had unfortunately to decline its commitment to BENE WP4 and to provide the CNGS horns. This has now been reorganized with the help of the CERN team that has inherited the CNGS task and the one of preserving the brilliant European tradition and know-how (S. Van der Meer) in the sector. Recently however a new IN2P3 laboratory (Strasbourg) has been able to resurrect the IN2P3 effort in collaboration with CERN and has taken up the leadership of the WP. ISS goals in this sector have been now defined and steady progress is again under way especially concerning the simulation of relevant effects and comparison with existing devices.

**WP5 (NOVEL NEUTRINO BEAMS)** main achievements of the 3 subgroups are:

- a) **WP5a (MUFRONT)**: progress on the design of the Front End of a neutrino factory. First indication of the range 6-10 GeV as the ideal proton driver energy for a neutrino factory, once all successive muon manipulations are also taken into account. Final approval of the MICE (Muon Ionization Cooling Experiment) at RAL in March. The MICE experiment is scheduled to start data-taking on April 1, 2007.
- b) **WP5b (MUEND)**: progress on the design of the acceleration stages of a neutrino factory. Progress in the direction of non-scaling FFAG and their use in full FFAG or combined FFAG/RAL acceleration schemes. The WP team is at the heart of the proposal of EMMA, an innovative electron model of non-scaling FFAG which a world collaboration hopes to build in Daresbury.
- c) **WP5c (BETABEAM)**: the WP keeps BENE informed and aware of the progress of the Beta-beam task in the EURISOL Design Study started on Feb.1 2005 that is systematically revisiting all aspects of the beta-beam chain. New ideas are also emerging: higher energy beta-beams are definitely very interesting; so are monochromatic beta-beams based on rare isotopes (Dysprosium) that undergo electron capture rather than beta decay. Though present studies are based on reutilization of existing CERN accelerators, the BETABEAM team is now also considering a green field study, in connection to the ISS and in view of the fairest possible comparison with neutrino factories performances. A special role is emerging for a first very low energy beta-beam (10-50 MeV neutrinos). This is likely to be the first beta-beam that will come into existence, providing an indispensable proof of principle demonstration and quite relevant physics results in the area of neutrino-nucleus cross-sections of astrophysical interest.

## N2.6 Overall Progress of Work Packages

The five following tables highlight the progress of work planned in the year 2005 for each work package by listing the lowest level subtasks of the BENE detailed implementation plan. No major deviations are reported.

### Work Package 1: PHYSICS

	Title	Original begin date (Annex 1)	Original end date (Annex1)	Estimated Status	Revised end date
<b>WP1</b>	<b>PHYSICS</b>				
1.1	Improvement of the WP Web Site	Jan. 2005	Mar 2005	95%	Continuously improving
1.2	WP Spring Meeting	Mar 2005	Mar 2005	100 %	
1.3	Assess physics analysis, motivate ISS	Jan 2005	Jun 2005	100%	Presented at Nufact05
1.4	WP Summer Meeting	Jun 2005	Jun 2005	100 %	Coincided this year with NuFact05
1.5	WP Fall Meeting	Nov 2005	Nov 2005	100 %	
1.6	Physics section of Interim Report	Jun 2005	Nov 2005	100 %	



## Work Package 2: DRIVER

	Title	Original begin date (Annex 1)	Original end date (Annex1)	Estimated Status	Revised end date
<b>WP2</b>	<b>DRIVER</b>				
2.1	Improvement of the WP Web Site	Jan 2005	Mar. 2005	95%	Continuously improving
2.2	Finalize criteria of SPL vs RCS comparison	Jan 2005	Mar. 2005	20% It is going to take longer!!	Larger picture emerging, CERN committee being set up
2.3	Identify R&D beyond HIPPI, motivate ISS	Jan 2005	Mar. 2005	100 %	Presented at Nufact05, ISS launched
2.4	WP Spring Meeting	Mar 2005	Mar 2005	100 %	
2.5	WP Summer Meeting	Jun 2005	Jun 2005	100 %	Coincided this year with NuFact05
2.6	WP Fall Meeting	Nov 2005	Nov 2005	100 %	
2.7	Driver section of Interim Report	Jun 2005	Nov 2005	100 %	

## Work Package 3: TARGET

	Title	Original begin date (Annex 1)	Original end date (Annex1)	Estimated Status	Revised end date
<b>WP3</b>	<b>TARGET</b>				
3.1	Improvement of the WP Web Site	Jan 2005	Mar. 2005	95%	Continuously improving
3.2	Summarize hi power target status, motivate ISS and other R&D	Jan 2005	Mar. 2005	100 %	Presented at Nufact05, ISS launched
3.3	WP Spring Meeting	Mar 2005	Mar 2005	100 %	
3.4	WP Summer Meeting	Jun 2005	Jun 2005	100 %	Coincided this year with NuFact05
3.5	WP Fall Meeting	Nov 2005	Nov 2005	100 %	
3.6	Target section of Interim Report	Jun 2005	Nov 2005	100 %	

## Work Package 4: COLLECTOR

	Title	Original begin date (Annex 1)	Original end date (Annex1)	Estimated Status	Revised end date
<b>WP4</b>	<b>COLLECTOR</b>				
4.1	Improvement of the WP Web Site	Jan 2005	Mar. 2005	95%	Continuously improving
4.2	Summarize collector progress, motivate ISS and other R&D	Jan 2005	Mar. 2005	100 %	Presented at Nufact05, ISS launched
4.3	WP Spring Meeting	Mar 2005	Mar 2005	100 %	
4.4	WP Summer Meeting	Jun 2005	Jun 2005	100 %	Coincided this year with NuFact05
4.5	WP Fall Meeting	Nov 2005	Nov 2005	100 %	
4.6	Collector section of Interim Report	Jun 2005	Nov 2005	100 %	

## Work Package 5: NOVEL NEUTRINO BEAMS

	Title	Original begin date (Annex 1)	Original end date (Annex1)	Estimated Status	Revised end date
<b>WP5</b>	<b>NOVEL NEUTRINO BEAMS</b>				
5.1	Improvement of the WP Web Site for the three areas of interest of the WP	Jan 2005	Mar. 2005	95%	Continuously improving
5.2	Review of existing designs for NuFact and Betabeams, motivate ISS	Jan 2005	Mar. 2005	100 %	Presented at Nufact05, ISS launched
5.3	WP Spring Meeting	Mar 2005	Mar 2005	100 %	
5.4	WP Summer Meeting	Jun 2005	Jun 2005	100 %	Coincided this year with NuFact05
5.5	WP Fall Meeting	Nov 2005	Nov 2005	100 %	
5.6	Novel beam sections of Interim Report	Jun 2005	Nov 2005	100 %	

## N2.7 Significant Achievements

- Start up of the beta-beam design study as part of the EURISOL DS
- Organization of the NNN05 and Nufact05 International Workshops in Europe.
- Approval of the MICE muon ionisation cooling experiment at RAL
- Approval of the MERIT high power target and collection experiment at CERN
- Launch of the International Scoping Study on Neutrino Factories & Super-beams.
- BENE Midterm Interim Scientific Report, contribution to the CERN Council Strategy process

## N2.8 List of all deliverables during the reporting period

N°	Deliverable Name	Workpackage	Lead Contractor(s)	Planned (in months)	Achieved (in months)
1	Proceedings of Nufact05 International Workshop	All WPs	INFN-Na	24	27 (sent to Publisher)
2	Launch of International Scoping Study on Neutrino Factories and Superbeams	All WPs	CCLRC, ICL, INFN-Na, Uni-Ge	18	18
3	Completion of Interim (Midterm) Scientific Report	All WPs	INFN-Na,	23	25
4	Annual report of the BENE network	All WPs	INFN-Na,	24	25

## N2.9 List of major meetings organized under BENE during the reporting period

Date	Title/subject	Location	Number of participants	Web Site Address
Mar 16-18 2005	BENE Week	CERN	70	<a href="http://nuspp.in2p3.fr/Bene/BENEWeekMarch05">http://nuspp.in2p3.fr/Bene/BENEWeekMarch05</a>
Apr 7-9 2005	NNN05 Workshop	Aussois, France	110	<a href="http://nnn05.in2p3.fr/">http://nnn05.in2p3.fr/</a>
6-7 May 2005	ISS preparation meeting	London	50	<a href="http://www.imperial.ac.uk/research/hep/events/nufact_meet.htm">http://www.imperial.ac.uk/research/hep/events/nufact_meet.htm</a>
12-20 Jun 2005	4th NuFact05 Summer School	Capri, Italy	22 students & 10 lecturers	<a href="http://nufact05school.na.infn.it/">http://nufact05school.na.infn.it/</a>
21-26 Jun 2005	7th NuFact05 Workshop	Frascati, Italy	190	<a href="http://www.lnf.infn.it/conference/2005/nufact05/">http://www.lnf.infn.it/conference/2005/nufact05/</a>
21-23 Sep 2005	1 <sup>st</sup> ISS general meeting	CERN	90	<a href="http://dpnc.unige.ch/users/blondel/ISSatCERN.htm">http://dpnc.unige.ch/users/blondel/ISSatCERN.htm</a>
Nov 22-25 2005	BENE05 Week at CARE05	CERN	60	<a href="http://nuspp.in2p3.fr/Bene/BENEWeekNov05">http://nuspp.in2p3.fr/Bene/BENEWeekNov05</a>

### 1.3.3 N3: High-Energy High-Intensity Hadron Beams (HHH)

HHH is the CARE network for High Energy High Intensity Hadron Beams. It comprises 8 countries plus CERN. The list of participants and their implication in the HHH Work Packages (C: Coordination, X: Participation) is given in the table below. The overall management is done by CERN.

Number	Participant	WP1 AMT	WP2 ABI	WP3 APD
1	CEA	X		
4	GSI	X	X	X
6	DESY		C	X
10	INFN	X		X
	INFN-Ge	X		
	INFN-LNF			X
	INFN-Mi	X		
	INFN-Na			X
	INFN-Sal			X
11	TEU	X		
15	WUT	X		
16	CSIC			X
	CIEMAT	X		
	LEII			X
17	CERN	C	C	C
19	PSI		X	
20	CCLRC	X		

In 2005 the networking activity of CARE-HHH was essentially focussed on the upgrade of the FAIR project at GSI and of the LHC accelerator complex at CERN. There was excellent progress on networking initiatives and technical aspects, in particular pulsed SC magnets, connections with Fusion (ITER) and US-LARP, magnet quench limits and LHC IR design, magnets for booster ring, beam instrumentation, and structured list of beam intensity limits.

#### N3.1 Overall Network Organisation and Main Activities

##### Overall Progress of the Activity

The overall progress of the HHH activity is described in the following Gantt chart which specifies the involvement of each contractor in the work packages and tasks.

A. ACTIVITY REPORT

ID	Task Name	2005	2006
		Qtr 3   Qtr 4   Qtr 1   Qtr 2   Qtr 3   Qtr 4	Qtr 1   Qtr 2   Qtr 3   Qtr 4
1	<b>N3: HHH Networking Activities</b>		
2	<b>All Work Packages</b>		
3	<b>Network coordination, dissemination, and outreach</b>		
4	<u>MS: Joint HHH/NED meeting at CARE04</u>		
5	General HHH meeting at CERN including non-EU partners		
6	<b>ID: HHH Annual Report 2004</b>		
7	Reinforce connections between Labs and Universities in all WPs		
8	Revisit priorities for all WP, improve HHH web site		
9	<u>MS: Annual HHH meeting</u>		
10	<b>ID: HHH Annual Report 2005</b>		
11	<b>WP1 Accelerator Magnet Technology (AMT)</b>		
12	<b>ID: Interim report on AMT activities and reporting at the general CARE meeting</b>		
13	<u>MS: General AMT meeting</u>		
14	Coordinate conductor development and tests		
15	<u>MS: AMT topical meeting on Insulation and Impregnation Techniques</u>		
16	<b>ID: Proceedings of the 1st AMT topical workshop on Accelerator Magnet Superconductors</b>		
17	<b>ID: Report on AMT organization and conductor development roadmap</b>		
18	Development of Web based database for SC Cables and Magnets		
19	<u>MS: Specific meeting on database</u>		
20	<b>ID: First report on Web based database</b>		
21	Codes and models for design, stability and protection studies for AMT1 and AMT4		
22	<u>MS: AMT mini-workshop on Beam Generated Heat and Magnet Quench Level</u>		
23	<b>ID: Proceedings of AMT mini-workshop on Beam Generated Heat and Magnet Quench Level</b>		
24	<u>MS: establish a catalog of existing codes for design, stability, and protection studies</u>		
25	<b>ID: Interim report on AMT activities and reporting at the general CARE meeting</b>		
26	Catalog and comparison of different IR options (AMT4)		
27	<u>MS: AMT workshop on Contact Tooling</u>		
28	Studies of fast pulsed SC magnets for Super-SPS		
29	Review of developments in the US and for ITER on conductors and magnet technology relevant for AMT1-2		
30	Comparative studies of alternatives using low field magnets for AMT2 and AMT3		
31	Determination of scaling law for magnet and cryogenic cost for AMT5		
32	<u>MS: Preliminary report on scaling law for magnet and cryogenic cost (roadmap)</u>		

A. ACTIVITY REPORT

ID	Task Name	2005	2006
		Qtr 3 Qtr 4 Qtr 1 Qtr 2 Qtr 3 Qtr 4	Qtr 1 Qtr 2 Qtr 3 Qtr 4
33	<b>WP2 Accelerator Beam Instrumentation (ABI)</b>		
34	<b>ID: Interim report on ABI activities and reporting at the general CARE meeting</b>		
35	<u>MS: 2nd ABI topical workshop on Beam Intensity and Lifetime measurements</u>		
36	<b>ID: Proceedings of the 2004 ABI topical workshops</b>		
37	Contribution to US-LARP activities/events and possible synergy with HHH WP1-WP3		
38	Study of tune control and remote diagnosis after identification of its limiting issues		
39	<u>MS: 3rd ABI topical workshop on Tune Control and remote diagnosis</u>		
40	<b>ID: Proceedings of the 3rd ABI topical workshop</b>		
41	<b>ID: Interim report on ABI activities and reporting at the general CARE meeting</b>		
42	Definition of possible new milestones		
43	<u>MS: 4th ABI topical workshop</u>		
44	<b>WP3 Accelerator Physics and Synchrotron Design (APD)</b>		
45	Further development of the APD Web Site with structured information flow		
46	<b>ID: Interim report on APD activities and reporting at the general CARE meeting</b>		
47	<u>MS: 1st APD topical workshop on Fast Synchrotrons and IR design HHH-2004</u>		
48	<u>MS: General APD meeting</u>		
49	<b>ID: Proceedings of the 1st APD topical workshop</b>		
50	Systematic comparison of alternative synchrotron and IR designs		
51	Determination of beam dynamics studies and experiments to validate different options (APD1-2, APD6-7)		
52	<u>MS: APD mini-workshop on Crystal Collimation</u>		
53	Studies relevant for APD3, APD4 and APD5, contribution to US-LARP events		
54	Identification of beam intensity limitations and determination of roadmap for Synchrotron and ID designs		
55	<u>MS: 2nd APD topical workshop on Fast Synchrotrons and IR design</u>		
56	<b>ID: Proceedings of the 2nd APD topical workshop</b>		
57	Establish a structured catalog of existing simulation codes for APD1-APD7		
58	Collect and document benchmarked codes		
59	<b>ID: Creation of a first web based code repository</b>		
60	<b>ID: Interim report on APD activities and reporting at the general CARE meeting</b>		
61	Definition of possible new milestones		
62	Definition of optics design options for IR layout and booster synchrotrons		
63	Assessment of impedance budget for booster synchrotrons		
64	<b>ID: First structured list of intensity limits for booster synchrotrons and LHC</b>		

Coordinators: F. Ruggiero and W. Scandale (CERN)

Goals/keywords:

- Roadmap for the upgrade of the European accelerator infrastructure (LHC and GSI accelerator complex)
  - luminosity and energy upgrade for the LHC
  - pulsed SC high intensity synchrotrons for the GSI and LHC complex
  - R&D and experimental studies at existing hadron accelerators
  - select and develop technologies providing viable design options
- Coordinate activities and foster future collaborations
  - integrate the effort of major laboratories
  - integrate the effort of small labs and universities
  - assemble a community capable of sustaining the technical realisation and scientific exploitation of these facilities
- Dissemination and outreach
  - create an information network, publish and document results
  - set up a web based beam dynamics code repository and a database for SC cable and magnets
  - discuss improvements for existing hadron beam facilities in Europe

Network web site: <http://care-hhh.web.cern.ch/care-hhh/>

- From there, the web pages of each Work Package, to be considered as an integral part of the HHH web site itself, can be easily accessed.

**Networking aspects:** Two specific working groups were created: the first addressing issues such as accelerator physics and machine-detector interface aspects related to the upgrade of the LHC Interaction Regions, the second investigating an appropriate R&D programme for AC superconducting magnets in view of the upgrade of the LHC injector complex and of FAIR at GSI.

**Deliverables:** A preliminary version of the web repository for accelerator physics codes was made available in the frame of WP3 (APD). Instead the work on the database for superconducting cable and magnets in the frame of WP1 (AMT) has been further delayed owing to serious difficulties in recruiting an appropriate fellow (two potential candidates have found a better position and withdrawn their application). A doctoral student has been finally selected and will start working on the AMT database in January 2006.

**Events:** A total of seven workshops were organized in 2005, three in the frame of WP1 (AMT), one in the frame of WP2 (ABI), and three in the frame of WP3 (APD). The participation was in general large and extended to several Institutions contributing to HHH. In many cases the participation was extended to representatives of the European Industry.

**Dissemination and outreach:** An intense effort was made for dissemination of information: several talks were given mostly by the HHH coordinators to illustrate the HHH activity in European laboratories and Universities or in workshops organized by other Institutions. Fifteen new publications, including four workshop proceedings, were issued in 2005 and are stored in the CARE database. Finally, the HHH web site was finalized and contains pages specific to each work-package and links to the HHH events and activities.

**Exchanges and educational aspects:** Two US accelerator specialists were hosted by CERN with the support of HHH in the frame of WP1 (AMT). Two junior scientists active in HHH issues were hosted and supported, one by CERN in the frame of WP1 (AMT), the other by the University of Sannio, Benevento, Italy in the frame of WP3 (APD). A master degree student was active at CERN on issues covered by WP1 (AMT). A master degree and a doctoral student just hired at CERN will investigate issues related to APD (D0 dipole) and AMT



database, respectively. Two doctoral students have been working at CERN in the frame of WP3 (APD) on LHC IR design aspects (dipole-first) and long-range beam-beam compensation, respectively, and a Summer Student has contributed to the setting-up of a dynamic accelerator-physics code web repository.

### Chronology of HHH networking initiatives:

- 3 February 2005 (dissemination): A seminar summarising the outcomes of the HHH-2004 workshop was organised at CERN, in the frame of the regular AB department seminars. The talk, with title *LHC Upgraded Taking Shape - Highlights of HHH-2004: "Beam Dynamics in Future Hadron Colliders and Rapidly Cycling Synchrotrons"*, was jointly presented by W. Scandale and F. Zimmermann to an audience of more than 50 experts. Part I: [http://care-hhh.web.cern.ch/care-hhh/Seminars/05-02-03hhh2004\\_WS.pdf](http://care-hhh.web.cern.ch/care-hhh/Seminars/05-02-03hhh2004_WS.pdf)  
Part II: [http://care-hhh.web.cern.ch/care-hhh/Seminars/hhh-2004\\_FZ.pdf](http://care-hhh.web.cern.ch/care-hhh/Seminars/hhh-2004_FZ.pdf).
- 2 March 2005 (coordination): CARE-HHH coordination meeting at CERN to review the HHH Network strategy, the sequence of future HHH events and the distribution of the P&M resources between the HHH working packages. <http://care-hhh.web.cern.ch/care-hhh/Meetings/CAREHHHcoordinationmeeting02032005.txt>. The main issues treated were:
  - Review of alternative options
  - Review of realistic milestones and project phases
  - Discussion on possible time-table for the LHC Luminosity Upgrade as requested by the CERN management.
 One of the outcomes of the meeting was the identification of a few tentative milestones for future LHC machine studies, listed here:
  - 2005/2006: installation and test of a beam-beam long range compensation system at RHIC to be validated with colliding beams
  - 2006/2007: new experiment for crystal collimation at the CERN-SPS
  - 2006: installation and test of Crab cavities at KEKB to validate higher beam-beam limit and higher luminosity with large crossing angles
  - 2007: if KEKB test successful, installation and test of Crab cavities in a hadron machine to validate low RF noise and emittance preservation.
- 30/03–2/04/2005 (dissemination): invited talk by W. Scandale at the workshop IFAE-05 in Catania (Italy) about *LHC Status and Possible Upgrade*. The meeting was organized by the INFN and attended by about 100 physicists (see web site <http://cms.ct.infn.it/ifae/>).
- 5–6 April 2005 (coordination): CARE steering committee held at CERN: F. Ruggiero presented the [status of CARE-HHH](#).
- 6–8 April 2005 (coordination): US-LARP Collaboration Meeting in Port Jefferson, USA (see web site [http://www.agrshichome.bnl.gov/LARP/050406\\_danfords/](http://www.agrshichome.bnl.gov/LARP/050406_danfords/)), attended by H. Schmickler. The main topic of discussion was the ‘Technical and resource loaded plans for FY06 and FY07’.
- 7–8 April 2005 (dissemination): invited talk by F. Ruggiero on [LHC Upgrade, R&D and Impact on LHC detectors](#) at the mini-workshop on *Future High Energy Accelerators*, CPPM, Marseille, France. Web site:

<http://maretude.in2p3.fr/cdsagenda/fullAgenda.php?ida=a0523>.

- 16–20 May 2005 (dissemination): contributions to the PAC 2005 conference in Knoxville, Tennessee, USA (web site <http://www.sns.gov/pac05/>). Submitted papers related to HHH: R. Ostojic, N. Catalan Lasheras, G. Kirby, and S. Russenschuck, *Low- $\beta$  Quadrupole Designs for the LHC Luminosity Upgrade*, [CARE-Conf-05-005-HHH](#)  
P. McIntyre and A. Sattarov, *On the Feasibility of a Tripler Upgrade for LHC*, [CARE-Conf-05-004-HHH](#) and *Killing the electron cloud effect in the LHC arcs*, [CARE-Conf-05-007-HHH](#)  
P. McIntyre, A. Sattarov, and J.-P. Koutchouk, *Towards an optimization of the LHC intersection region using new magnet technology*, [CARE-Conf-05-006-HHH](#)  
G. Arduini, V. Baglin, J.M. Jimenez, F. Ruggiero, D. Schulte, and F. Zimmermann, *Electron Cloud Measurements in the SPS in 2004*, [CARE-Conf-05-021-HHH](#).
- o 28/5–1/6/2005 (dissemination): invited contribution to the HIF 2005 workshop organized by the INFN (web site <http://www.pi.infn.it/hif/>). W. Scandale presented a talk on [High Intensity Injector Chain for the LHC](#).
- June 2005 (coordination): the two HHH coordinators became members of the “Proton Accelerators for the Future” working group newly created at CERN.
- 5 July 2005 (dissemination): invited contribution to the XXII International Lepton-Photon Symposium in Uppsala, Sweden (web site <http://lp2005.tsl.uu.se/~lp2005/>). F. Zimmermann presented a talk on [R&D for Future Accelerators](#).
- July 2005 (dissemination): written contribution to the HIP05 proceedings by W. Scandale on [Possible scenarios for the LHC upgrade](#).
- 18–20 July 2005 (dissemination): contribution to the ATLAS Tracker Upgrade Workshop in Genova with more than 100 participants (see web-site: <http://atu-2005.ge.infn.it/>). F. Ruggiero gave a presentation on [LHC machine upgrade plans](#).
- o 28/9–01/10/2005 (dissemination): contribution to the 8<sup>th</sup> ICFA Seminar on *Future Perspectives in High Energy Physics*, Kyungpook National University, Daegu, Korea, with about 170 participants (see web site: <http://chep.knu.ac.kr/ICFA-Seminar/>). F. Ruggiero presented the plans for the [LHC Luminosity Upgrade](#).
- o 5–6 October 2005 (coordination): US-LARP Collaboration Meeting at FNAL, attended by F. Ruggiero. About 35 participants (see web site <http://larp.fnal.gov/Oct05Collaboration/>).
- o 24 October 2005 (coordination): HHH coordination meeting at CERN in view of the annual meeting CARE05.
- o 23–25 November 2005 (all Work Packages): contribution to the [CARE05](#) annual meeting. Several HHH parallel sessions, two ‘highlights talks’ and a summary talk:



- J.-P. Koutchouk, [Recent Results on Insertion Design for the LHC Luminosity Upgrade](#), HHH highlight talk
- L. Bottura, [Recent activities/results on pulsed SC magnet for the CERN and GSI accelerator complex](#), HHH highlight talk
- F. Ruggiero, [CARE-HHH Networking Activity in 2005](#), HHH summary talk.

Preliminary conclusions discussed at CARE05 for the LHC Luminosity Upgrade are that: (i) we do need a back-up or intermediate IR upgrade option based on NbTi magnets whose luminosity reach needs to be assessed, (ii) a vigorous R&D programme on Nb<sub>3</sub>Sn magnets should start at CERN, complementary to the US-LARP programme, to reach a peak LHC luminosity of  $10^{35} \text{ cm}^{-2} \text{ s}^{-1}$  after 2015, (iii) a vigorous R&D programme on pulsed superconducting magnets should be pursued within CARE-HHH leading to an upgrade of the GSI and LHC injector complex thus allowing to maximize the integrated luminosity, and (iv) alternative LHC IR layouts need to be rated in terms of technological and operational risks/advantages, in view of defining an LHC Upgrade baseline design possibly already by the end of 2006.

### **N3.2 Work Package 1: Advancements in Accelerator Magnet Technologies (AMT)**

Coordinator: L. Rossi (CERN), deputy: L. Bottura (CERN).

Keywords: stability and quench limit of LHC insertion magnets,  
pulsed magnets for LHC and GSI accelerator complex upgrade,  
magnets for booster ring,  
high field magnet design,  
optimisation of the overall cost.

CARE-HHH-AMT web site: <http://amt.web.cern.ch/amt/>.

During 2005 there was good progress on conductor development, codes and models for design, stability and protection studies, comparison of different IR options and scaling laws, as well as some preliminary work on the database for SC cable and magnets. A report on *AMT organization and Conductor Development Roadmap* (Intermediate Delivery) was presented at the HHH-AMT general meeting held at CERN on 11-12 November 2004, see [http://amt.web.cern.ch/amt/events/meetings/CERN\\_Nov\\_2004/meeting\\_CERN\\_nov2004.htm](http://amt.web.cern.ch/amt/events/meetings/CERN_Nov_2004/meeting_CERN_nov2004.htm)

There was also excellent progress on the study of fast-pulsed SC magnets (GSI FAIR project and Super-SPS) and low-field magnets for a booster ring in the LHC tunnel. Strong synergy was established with HHH-APD (LHC IR design and high energy injectors), HHH-ABI (machine protection), fusion magnet technology, and US-LARP.

An AMT workshop on Contact Tooling was delayed to 2006 (in a joint workshop on Accelerator Magnet Design and Optimization, 'WAMDO', to be organized in Archamps, France, 3–7 April 2006) and replaced by the 'ECOMAG-05' workshop on *SC Pulsed Magnets for Accelerators*.

#### **Chronology of HHH-AMT events and initiatives:**

- 17–18 February 2005: A meeting held at CERN on the design and the prototyping of a fast-ramping superconducting pulsed dipole. The attendance was of 20 experts from CERN, INFN, GSI and CEA. The discussion covered the following items:
  - Possible dipole specifications either for the construction of SIS 300 at GSI or for the upgrade of the SPS at CERN
  - Investigation on the possibility to develop a common prototyping program

- Possible wire and cable specifications
- Creation of a working group, named PMWG, for the follow up of the future R & D, see the web <http://pmwg.web.cern.ch/PMWG/>.
- 3–4 March 2005: A CARE-HHH-AMT workshop was organized at CERN on *Beam-Generated Heat Deposition and Quench Levels*. 80 specialists from CERN, INFN, CEA, IFJ-Krakow, GSI, DESY, FNAL, University of Geneva and from SIEMENS attended it. [http://amt.web.cern.ch/amt/events/workshops/beam\\_heat\\_2005/announcement.htm](http://amt.web.cern.ch/amt/events/workshops/beam_heat_2005/announcement.htm).

The main topics were:

- Study of the stability margin for the SC focusing triplet at the ultimate luminosity level
- Validation of the SC quadrupole design for the LHC luminosity upgrade
- Thermal transfer and superconducting stability
- Thermal models and their validation through experiments
- Comparison of codes for the simulation of thermal effects
- Experience on quench level from LHC magnet operation and test at CERN, and from beam and magnet operation at other laboratories in the world.

The main outcomes, very useful also for LHC commissioning, were:

- magnet stability and heat deposition code benchmarking
- generated concrete work on tables for quench limits for all LHC magnets.
- March–April 2005: Visit at CERN of P. McIntyre (University of Huston, Texas, USA) as HHH-AMT consultant for about four weeks. The main outcomes of the collaboration were:
  - 18/03/2005: seminar at CERN on [\*Super Dipoles for Super Colliders\*](#), to an audience of 35 specialists
  - 21&30/03/2005: discussions at CERN on (i) advanced SC magnet technology and design, (ii) radiation resistant dipole to be used in dipole-first IR design (iii) chromaticity correction for quadrupole-first IR design, (iv) LHC energy tripler using hybrid SC magnets, (v) possible counter-measures against electron cloud (see also <http://care-hhh.web.cern.ch/care-hhh/meetings.htm>)
  - 04/04/2005 seminar at CERN [\*Optimizing IR design for the LHC luminosity upgrade\*](#)
  - 14/04/2005 seminar at CERN [\*On the Feasibility of a Tripler Upgrade for LHC\*](#)
  - 15/04/2005 seminar at CERN [\*Novel Method to Avoid Electron Cloud Limitations in the LHC\*](#)
  - 18&20/04/2005 seminars in CEA-Saclay and Dipartimento di Fisica, Milano on *LHC Energy Tripler*.

- 22–23 March 2005: CARE-HHH-AMT Topical Meeting at CERN on *Insulation and Impregnation Techniques*. About 30 specialists from CERN, LBLN, INFN, University of Twente, GSI, University of Texas, KEK, CEA, CIEMAT, MIT, NSCL, CCLRC and Industry (ANSALDO, ANSALDO, Fraivillig Fraivillig Technologies, Composite Technology Development) were present.

Web site: <http://at-hhh-amt.web.cern.ch/AT-HHH-AMT/>.

The main topics were:

- SC conductor insulation;
- Insulation of metallic parts;
- Insulation of inter-layers;
- Resin composition;
- Radiation resistance;
- Fibre filling and sizing;
- Heat transfer properties (synergy with Insulation Work Package in NED).

Main outcome: it is difficult to identify a single material with all the required mechanical properties. The best candidate is a ‘polymide spray’.

- April 2005: Submission of the following NEST proposals:
  - ‘ECOMAG’ for the Fast SC pulsed magnet for GSI and LHC injector upgrade: CERN (Scandale), GSI (Moritz), INFN (Volpini, Fabbricatore), CEA/Saclay (Rifflet);
  - ‘Electron model of FFAg’, CERN (marginally) involved for LHC accelerator complex upgrade: UK(CCLRC-Lancaster-Liverpool-Oxford)-CERN-CEA/Saclay
  - ‘Eurodip’, a possible extension of NED: CERN-CEA/Saclay-CIEM;
- 19–20 May 2005: second meeting of the Pulsed Magnet Working Group, 19 participants, (see minutes at <http://pmwg.web.cern.ch/PMWG/2nd%20meeting.htm>).

The main goals were:

- to define an inventory of resources (tooling and personnel) which may become available,
- to review the present activity and identify possible synergies within presently available resources,
- to discuss the organization of the CARE-HHH-AMT workshop in Frascati.
- June 2005: A. Devred took part in the DOE review of LARP at FNAL. There was also a ‘Chats’ meeting at Twente Univ. organized by A. Nijhuis, with one HHH day devoted to a discussion of quench phenomena in superconducting magnets.
- 28/9–14/10/2005: Visit of H. Piekarczyk (Fermilab, Illinois, USA) at CERN as HHH-AMT consultant for about two weeks. The main outcomes of the collaboration were:
  - proposal of the integration of a pipetron-like injector in the LHC tunnel in collaboration with G. De Rijk (CERN);
  - 10/10/2005: seminar at CERN on ‘Pipetron Technology’;
  - 13/10/2005: discussions at CERN on the possibility to use a pipetron-like injector for LHC, to be installed in the LHC tunnel providing protons of up to 1.5 TeV/c momentum.
- 26–28 October 2005: CARE-HHH-AMT Workshop ‘ECOMAG05’ on *SC Pulsed Magnets for Accelerators*, Frascati (Italy), 70 participants from CERN, INFN ENEA, GSI, CEA, EPFL, JINR, MIT, CIEMAT, KEK, IHEP, EFDA, Bochvar Institute of Inorganic Materials, University of Twente, Ohio State University and from 6 European Industries acting on SC magnets or SC materials (Alstom, Accell, NBB, Bruker BioSpin, Ouctokumpu, Ansaldo). Strong synergy with HHH-APD.

Web site <http://ecomag-05.web.cern.ch/ecomag-05/>.

Topics:

- define a set of agreed parameters for the development of SC magnets ranging from low field, continuously pulsed (typically 2 T peak, 4 T/s, 100 mm aperture,  $10^8$  cycles) to medium field, high-duty cycle magnets for storage and booster rings (typically 6 T peak, 1 T/s, 80 mm aperture,  $10^6$  cycles),
- translate the requirements into specifications for performance of strand, cable, magnet and auxiliaries,
- define the R&D required to achieve the above specifications and produce a tentative road-map for a procurement and prototyping activity.

The main goal is to achieve *common magnet parameters for CERN and GSI*.

- 11 November 2005: Debriefing of the outcome of the workshop ECOMAG05, aiming at:
  - Synthesis of the discussions of the ECOMAG05

- Identification of a possible roadmap for the R&D on AC superconducting magnets at CERN and GSI
- Proposal for common developments and technical solutions
- 30 participants.

### Overall Progress of Work Package 1

The following table highlights the progress of work planned in the year 2005 for work package WP1 by listing the lowest level subtasks of the HHH detailed implementation plan.

Title	Original begin date	Original end date	Estimated Status	Revised end date
<b>WP1 : Advancements in Accelerator Magnet Technologies (AMT)</b>				
MS: AMT topical meeting on Insulation and Impregnation Techniques	T1-2005	T1-2005	100 %	On time: T1-2005
MS: AMT workshop on Beam Generated heat and Magnet Quench Level	T1-2005	T1-2005	100 %	On time: T1-2005
Web-based database for SC cable and magnets	T3-2004	T4-2006	10 %	Delayed to T4-2007
MS: specific meeting on database	T2-2005	T2-2005	0 %	Delayed to T4-2005
ID: first report on web based database	T2-2005	T2-2005	0 %	Delayed to T4-2005
Catalogue of numerical codes for AMT1 and AMT4	T1-2004	T4-2005	20 %	Delayed to T4-2006
Comparison of codes for AMT1 and AMT4	T1-2004	T2-2004	20 %	Delayed to T4-2005
Identifications of main limiting issues	T2-2004	T4-2004	20 %	Delayed to T2-2005
ID: Proceedings of the first topical workshop on superconductors	T1-2005	T1-2005	100 %	On time: T1-2005
ID: report on AMT organization and conductor development	T1-2005	T1-2005	80 %	Delayed to T3-2005
Comparative studies of alternatives using low field magnets for AMT2 and AMT3	T3-2004	T4-2004	30 %	Delayed to T3-2005
Identification of general issues relevant for magnet design for AMT5	T3-2004	T4-2004	10 %	Delayed to T4-2005
Review of the development in US and for ITER on conductors and magnet technology relevant for AMT1 and AMT2	T1-2005	T1-2005	90 %	Delayed to T3-2005
Comparative studies for alternatives using low field magnets for AMT2 and AMT3	T4-2004	T2-2005	20 %	Delayed to T4-2005
Determination of scaling law for magnets and cryogenic cost for AMT5	T4-2004	T2-2005	20 %	Delayed to T3-2005
MS: preliminary report on scaling law for magnets and cryogenic cost for AMT5	T2-2006	T2-2006	20%	Delayed to T4-2006

### N3.3 Work Package 2: Novel Methods for Accelerator Beam Instrumentation (ABI)

Coordinator: H. Schmickler (CERN), deputy: K. Wittenburg (DESY).

Keywords: tools and diagnostic systems for luminosity,  
 wire for beam-beam compensation,  
 advanced transverse beam diagnostics,  
 feedback loops for orbit, chromaticity and coupling,  
 advanced beam halo diagnostics,

remote diagnostics and maintenance of instrumentation.

CARE-HHH-ABI web site: [http://adweb.desy.de/mdi/ABI\\_new.html](http://adweb.desy.de/mdi/ABI_new.html).

The active collaboration and coordination on Beam Instrumentation issues has been continued with the US-LARP programme. H. Schmickler and other CERN colleagues have attended a US-LARP collaboration meeting at [Port Jefferson](#) (6–8 April 2005) and several video-conferences. Another active collaboration has been established between ABI and AMT. K. Wittenburg has attended the AMT Workshop on [Beam-generated heat deposition and quench levels in LHC magnets](#) held at CERN, 3–4 March 2005. As a spin-off, a DESY-CERN collaboration in machine protection issues has been established: (i) a fast detection circuit for magnet power supply failures was developed for DESY and transferred to CERN. (ii) some LHC beam loss monitor are installed in HERA and tests are ongoing to check their system properties.

A spin-off from the first CARE-HHH-ABI workshop on [Trajectory and Beam position measurements using digital techniques](#) has been established in the form of a common EU-FP6 design study work between CERN, GSI, TU Darmstadt, FZ Jülich and the company I-Tech on digital beam position measurements.

### Chronology of HHH-ABI events and initiatives:

- April 2005: the Proceedings of the 1<sup>st</sup> CARE-N3-ABI networking meeting (held in Aumühle, 22–23/06/2004) on *Trajectory and Beam position measurements using digital techniques*, have been published as [CARE-Conf-04-024-HHH](#). The Proceedings of the 2<sup>nd</sup> CARE-HHH-ABI networking meeting (held in Lyon, 1–2/12/2004) on *DC current transformers and beam-lifetime evaluations* have the reference [CARE-Conf-04-023-HHH](#). The experience from the major three European laboratories working with hadron beams (DESY, GSI, CERN) and experience from SNS and BNL in the US (RHIC machine) were considered. The experience was complemented by two participants from an industrial company. As a first spin-off from this workshop, the lifetime measurement and indicator for the long lifetimes at the DESY storage rings were substantially improved in 2005.
- 6–8 June 2005: During the [DIPAC2005](#) conference an ABI coordination meeting between DESY, GSI and CERN had taken place to review and redefine the future CARE-HHH-ABI activities. Three major results were the outcome of the review: (1) The financial situation for the ABI activities will allow only one workshop per year. That implies a related change of the ‘*deliverables for ABI*’. (2) ABI should proceed with their concept of small workshops with its very dedicated and specialized topics. These events should not be and are not in concurrence with more general instrumentation workshops like DIPAC or BIW. The previous ABI workshops were very successful not only in the sense of creating networking activities, but also in creating real solutions for present problems. (3) The general scope of ABI will remain unchanged. However, a change of some ABI activities were necessary to keep the workshop topics close to present problems. A new tentative list of ABI activities was generated during this meeting and is reported at the end of the section.
- o 6–7 December 2005: CARE-HHH-ABI Workshop on *Remote diagnostics and maintenance of beam instrumentation devices*, Hirschberg (close to Heidelberg, Germany), attended by about 20 invited contributors associated to CARE. Web site: <http://adweb.desy.de/mdi/CARE/Hirschberg/ABI-Hirschberg.htm>  
The focus of HHH-ABI includes improving LHC commissioning and operation, in addition to GSI and LHC Upgrade, and the associated need for remote diagnostics and maintenance for beam instrumentation provided by CERN partners such as US-LARP.  
Workshop Goals:

- i. define realistic objectives for the operation and diagnostics of future hadron accelerators (including LHC at FNAL),
- ii. discuss in detail related technology issues and controls infrastructure,
- iii. propose HHH-ABI tasks and milestones for the coming 18 months:
  - 1<sup>st</sup> half day: The Global Accelerator Network-Multipurpose Virtual Laboratory initiative and others
  - 2<sup>nd</sup> half day: Virtual Instrumentation Integration – principles and examples
  - 3<sup>rd</sup> half day: Definition of work packages from the diagnostics view point.
- It is planned to have a CARE-HHH-ABI workshop in 2006 on *Luminosity Measurements* very close to the American Beam Instrumentation Workshop ‘BIW06’, May 1–4, 2006.

### **Detailed description of activities to be coordinated within the HHH-ABI Work Package**

#### **ABI1: Studying tools and diagnostic systems for luminosity monitoring and steering**

- i. Identify new solutions for successful Luminosity steering
- ii. Procedures for (automated) beam finding and centring without significant beam blow-up, losses and background in the Experiments
- iii. What is the best physics process to detect as measure of luminosity?

#### **ABI2: Studies on the applicability of a wire compensation for long range beam-beam interactions**

This activity is covered by a US-LARP collaboration, therefore no dedicated ABI workshop is planned. An active ABI contribution to the LARP collaboration is foreseen.

- i. Design and specification of the wire and the required diagnostics system in the machine (positioning of wire, wire shapes, tolerances etc.).
- ii. Comparison to other solutions (electron lens); what meets best the functional specifications?
- iii. Test in machine studies such a system in existing proton storage rings, discussion of results

#### **ABI3. Studies on advanced transverse beam diagnostics**

- i. Continuous tune tracking: What is the best process to use? Improvements on low excitation Phase locked loop systems (multi-carrier PLLs...)
- ii. Fast, non-destructive chromaticity measurements: Based on tune tracking and periodic modulation of beam momentum? Modulation frequency above or below the synchrotron tune? Based on the measurement of the phase shift of the betatron motion of the beam head- and tail particles?
- iii. Fast, non-destructive coupling measurements: Development of algorithms to extract coupling information from turn by turn beam position monitor readings
- iv. Fast, non destructive profile measurement: Development of high precision profile monitors for high intense hadron beams.
- v. Test some of the above proposals in prototype installations in existing hadron machines.

#### **ABI4. Implementation of fast feedback loops for orbit, coupling and chromaticity control**

- i. Test in machine studies such a system in existing proton storage rings.
- ii. Suggest improvement to long-term stability of sensors
- iii. Test and implementation of fast digital readout electronics for BPMs (1<sup>st</sup> ABI workshop in Aumühle)

#### **ABI5: Studies on advanced beam halo diagnostics**

Participation on Halo03 workshop, an ABI workshop is foreseen for a latter time.



- i. Profile Monitors for direct measurement of the beam halo with good transverse resolution. The technological challenge will be a dynamic range of typically six orders of magnitude for the profile monitors.
- ii. Halo Interceptive monitors and related mathematical models to deduce halo distribution
- iii. Test some of the above proposals in prototype installations in existing hadron machines.

#### **ABI6: Studies leading to remote diagnostics and maintenance of instrumentation devices**

A workshop dedicated to that topic should be held in the near future (see Hirschberg 2005)

- i. Prepare controls infrastructure (network permissions...) to be able to diagnose and/or change settings of instrumentation devices in other laboratories.
- ii. Create « political » acceptance for such installations.
- iii. Requirements of diagnostic tools for global accelerator network (GAN)

#### **ABI7: Studying tools for diagnostic systems for high intense pre-accelerators; preservation of emittance in the accelerator chain**

- i. Identify hardware solutions for instrumentation in a radiation hard environment.
- ii. Identify hardware requirements for transversal beam diagnostics.
- iii. Identify hardware requirements for longitudinal beam diagnostics.
- iv. Measurement of space charge effects on the beam as well as on the instrument.

#### **ABI8: Requirements of diagnostic tools for machine protection systems (MPS)**

- i. Studying the precision on AC and DC beam current monitors for beam lifetime analyses and fast machine protection. ✓(2nd ABI workshop in Lyon)
- ii. Requirements on beam loss monitor systems for machine and quench protection (joint with AMT) ✓(AMT Workshop)
- iii. Identifying diagnostic instruments and systems which can be used as reliable MPS transducer.
- iv. Test some of the above proposals in prototype installations in existing hadron machines. ✓(LHC BLM installation in HERA)

### **Overall Progress of Work Package 2**

The following table highlights the progress of work planned in the year 2005 for work package WP2 by listing the lowest level subtasks of the HHH detailed implementation plan.

Title	Original begin date	Original end date	Estimated Status	Revised end date
<b>WP2: Novel Methods for Accelerator Beam Instrumentation (ABI)</b>				
ID: proceedings of the first ABI topical workshop	T1-2005	T1-2006	100 %	On time: T1-2005
ID: proceedings of the second ABI workshop	T2-2005	T3-2005	100 %	On time: T2-2005

### **N3.4 Work Package 3: Accelerator Physics and Synchrotron Design (APD)**

Coordinator: F. Ruggiero (CERN), deputy: F. Zimmermann (CERN).

Keywords: interaction Region design for LHC luminosity upgrade,  
 optics design for booster synchrotrons,  
 impedance calculations,  
 structured list of intensity limits,  
 electron cloud effects, beam measurements,  
 advanced theoretical studies on halo formation and loss mechanisms.

Web site: <http://care-hhh.web.cern.ch/care-hhh/CARE-HHH-APD/CARE-HHH-APD.html>.

During 2005 there was good progress on the comparison of alternative LHC IR designs, synchrotron design, beam dynamics studies and tests to validate different options. Electron

cloud and crystal collimation tests have been performed at FNAL, while electron cloud and long range beam-beam compensation tests initially planned at RHIC will be delayed to September 2006, after severe budget cuts at BNL. Contacts have been established with KEK, Cornell and LBNL regarding a possible design for LHC crab cavities to be tested at RHIC. There was significant progress also on code benchmarking and development of a web code repository. HHH-APD results in 2005 include:

- Excellent progress toward a structured list of beam intensity limits
- Initial work on optics solutions, RF upgrade paths, collimation and machine protection for pulsed SC synchrotrons
- Strong synergy with HHH-AMT (LHC IR design and High Energy Injectors) and US-LARP. Some synergy with MW Proton Driver studies.
- A CARE-HHH-APD workshop *Towards a Roadmap for the Upgrade of the LHC and GSI Accelerator Complex* is foreseen in the second half of 2006.

### Chronology of HHH-APD events and initiatives:

14 January 2005: Meeting at CERN between Accelerator Experts and representatives of ATLAS and CMS Physicists to discuss LHC Luminosity Upgrade issues, with 7 participants (see <http://care-hhh.web.cern.ch/care-hhh/Meetings/LHCUG20050114.txt>).

The discussion covered the following topics:

- Possible scenarios for the reduction of  $\beta^*$
- Possible scenarios to increase the number of bunches and discussion on the expected consequences for the experimental apparatus and on cost effectiveness aspects
- Possible scenarios to compensate long range beam-beam, with a specific discussion on the idea of using a split-wall chamber to shield the AC long range beam-beam in the common pipe close to the LHC Interaction Points
- Proposal of a common investigation of the interaction debris in an upgraded version of the inner triplet quadrupoles, using Monte-Carlo simulation programs.

To deal with the follow-up of the treated items a stable working group and forum of discussion, called LUMIUP, with periodic meetings, has been created.

- January 2005: A CERN Doctoral Student from Univ. Rome, R. De Maria, has started working on optics aspects of the LHC IR upgrade (dipole-first option) under the supervision of O. Brüning.
- 7–8 March 2005: the CARE-HHH-APD mini-workshop ‘CC-2005’ on *Crystal Collimation in Hadron Colliders* was organized at CERN.

Web site: <http://care-hhh.web.cern.ch/CARE%2DHHH/CrystalCollimation/>.

About 80 specialists from CERN, INFN, PNPI, IHEP, FNAL, LBNL, University of Aarhus, Helsinki Institute of Physics and University of Texas attended it.

The main topics were:

- Review of the beam cleaning requirements
- Review of crystal extraction experiments in circular accelerators
- Experience with crystals at the various colliders
- Crystal production, technologies and experimental procedures
- Crystal simulation
- Discussion on a proposal of a new experiment of crystal extraction and collimation at the CERN-SPS.

Main outcomes:

- Negative results at RHIC may depend on crystal quality.
- New SPS experiment has been proposed (and financed by INFN).



- Meanwhile excellent crystal collimation results have been observed at the Tevatron.
- 2<sup>nd</sup> CARE-HHH-APD mini-workshop on *Crystal Channeling* in December 2005.
- April 2005: the proceedings of the workshop HHH-2004 have been completed and made available for publication as CARE and (in June 2005) as CERN Yellow Report, see: [http://care-hhh.web.cern.ch/CARE-HHH/HHH-2004/Proceedings/proceedings\\_hhh2004.htm](http://care-hhh.web.cern.ch/CARE-HHH/HHH-2004/Proceedings/proceedings_hhh2004.htm).
- April 2005: a paper written by W. Scandale and F. Zimmermann, summarising the outcome of the HHH-2004 workshop, was published in the April 2005 issue of the CERN-Courier, see <http://cerncourier.com/main/article/45/3/29>. A key outcome is the elimination of the ‘superbunch’ scheme for the LHC upgrade, in which each proton beam is concentrated into only one or a few long bunches. This option would pose unsolvable problems for the detectors, the beam dump and the collimator system.
- April 2005: A CERN Doctoral Student from Univ. Vienna, U. Dorda, has started performing simulation studies of long-range beam-beam compensation for the LHC luminosity upgrade under the supervision of F. Zimmermann.
- April 2005: Preliminary discussions with M. Klein (DESY) and J. Dainton (Un. Liverpool) about “QCD-explorer”: colliding  $\sim 1$  TeV proton (or ion) beam from Tevatron or Super-SPS with 20-75 GeV electron beam from ILC or CLIC (first stage).
- 13 April 2005: second meeting ‘LUMIUP’ on LHC luminosity upgrade with ATLAS and CMS physicists (8 participants). Items discussed: possible IR upgrade scenarios and implementation, identification of a team to estimate high luminosity effects of interaction debris on the superconducting triplets.
- June 2005: publication of the proceedings of the workshop HHH-2004. See <http://cdsweb.cern.ch/search.py?recid=813387&ln=en>.
- July–August 2005: A CERN Summer Student from Univ. Belfort (R. Basset) collaborated with F. Zimmermann to develop web pages for CARE-HHH and in particular a dynamic accelerator-physics web-based code repository.
- 8 July 2005: Contribution to the 61<sup>th</sup> meeting of the LHC collimation working group (see minutes at [http://lhc-collimation.web.cern.ch/lhc-collimation/files/minutes\\_2005-07-08.pdf](http://lhc-collimation.web.cern.ch/lhc-collimation/files/minutes_2005-07-08.pdf)). W. Scandale presented a possible scenario to investigate crystal collimation in the SPS in view of the LHC intensity upgrade (see transparencies at [http://lhc-collimation.web.cern.ch/lhc-collimation/files/WScandale\\_1\\_2005-07-08.pdf](http://lhc-collimation.web.cern.ch/lhc-collimation/files/WScandale_1_2005-07-08.pdf)).
- July 2005: Completion of the proceedings of the workshop CC-2005, [http://care-hhh.web.cern.ch/CARE%2DHHH/CrystalCollimation/Proceedings/proceedings\\_cc2005.htm](http://care-hhh.web.cern.ch/CARE%2DHHH/CrystalCollimation/Proceedings/proceedings_cc2005.htm).
- July 2005: Creation of the web page for the CARE-HHH-APD work-package. <http://care-hhh.web.cern.ch/care-hhh/CARE-HHH-APD/CARE-HHH-APD.html>.
- July 2005: Preliminary version of the web based code repository included in the CARE-HHH-APD work-packages. Web site: [http://care-hhh.web.cern.ch/care-hhh/simulation\\_codes\\_catalogue\\_and\\_repository.htm](http://care-hhh.web.cern.ch/care-hhh/simulation_codes_catalogue_and_repository.htm)
- 31/08–3/09/2005: CARE-HHH-APD Workshop ‘LHC-LUMI-05’ on *Scenarios for the LHC luminosity upgrade*, Arcidosso (Italy), web site: <http://care-hhh.web.cern.ch/CARE-HHH/LUMI-05/>. About 40 participants attended the meeting. Strong synergy with US-LARP mini-workshop ‘IR-2005’ and CARE-HHH-AMT workshop ‘ECOMAG05’. The main topics were:
  - Optical designs and luminosity performance for alternative IR layouts: dipole-first vs

- quadrupole-first (Nb-Ti or Ni<sub>3</sub>Sn) vs ironless magnet at very low  $\beta^*$
- Beam-beam compensation schemes and machine-experiment interface (reduced  $\ell^*$ )
- Machine and magnet parameters for new high energy injectors (Super-SPS) needed to increase integrated LHC luminosity.

Main outcomes:

- Three IR layout options identified (HHH web repository with optics solutions set up):
    - 1) dipole-first based on Nb<sub>3</sub>Sn technology with  $\ell^* = 19$  m
    - 2) quadrupole-first layout based on Nb<sub>3</sub>Sn technology  $\ell^* = 19$  m
    - 3) low-gradient quadrupole-first layout based on NbTi technology
  - Early beam separation by a “D0” dipole located a few metres away from the IP
  - RF systems and bunch spacing
  - Proposal of a new Super-PS.
- 19–22 September 2005: visit of T. Demma (Univ. of Sannio, Benevento, Italy) at CERN in the CARE-HHH framework, to launch a collaboration on LHC beam dynamics and in particular analytic map techniques derived from simulation results and allowing a fast evaluation of the electron cloud build-up, successfully applied to the study of different bunch patterns in RHIC.
  - 3–4 October 2005: US-LARP mini-Workshop on *LHC IR upgrade*, FNAL, attended by 3 CERN scientists associated to CARE. Web site: <http://larp.fnal.gov/IR2005/>.  
Topics:
    - Heat deposition and magnet quench limits,
    - TAS/TAN integration and follow-up of HHH-2004 workshop
    - Feasibility of large crossing angles and CRAB cavities in hadron storage rings
    - Beam-beam compensation schemes.
 Contacts were also established with KEK, Cornell and LBNL regarding a possible design for LHC crab cavities.
  - October 2005: Two newly recruited CERN staff members, G. Rumolo and R. Tomàs, have started working at 50% of their time on optics aspects and collective effects in the LHC injector complex within the HHH framework.
  - 10 November 2005: LHC Seminar given by F. Ruggiero and W. Scandale at CERN, attended by some 120 scientists, to summarize the outcome of the LHC-LUMI-05 workshop on *Scenarios for the LHC Luminosity Upgrade* (see announcement at <http://agenda.cern.ch/fullAgenda.php?id=a057227>)
    - F. Ruggiero, *Interaction Region Upgrade*,
    - W. Scandale, *LHC Injector Complex Upgrade*.
  - 8–9 December 2005: 2<sup>nd</sup> CARE-HHH-APD mini-Workshop on *Crystal Channeling and Collimation in Hadron Storage Rings*, CERN, Geneva, Switzerland, 10 participants, web site: <http://care-crystalchanneling.web.cern.ch/care-crystalchanneling/>  
Topics:
    - Review of crystal collimation data from several colliders, including recent results at the Tevatron, new materials and techniques for channeling of relativistic particles
    - Detectors for the INTAS experimental program and observation of particle beam reflection from bent atomic planes
    - Proposal to study proton small-angle scattering by oriented crystals on a CERN SPS extracted beam. Possible follow-up at a co-organized International Conference on *Charged and Neutral Particles Channeling Phenomena* in July 2007 at Frascati.

### Overall Progress of Work Package 3

The following table highlights the progress of work planned in the year 2004 for work package WP3 by listing the lowest level subtasks of the HHH detailed implementation plan.

Title	Original begin date	Original end date	Estimated Status	Revised end date
<b>WP3: Accelerator Physics and Synchrotron Design (APD)</b>				
Comparison of alternative synchrotron and IR design (now including systematic rating)	T1-2004	T2-2004	75 %	Delayed to T3-2006
ID: proceedings of the first APD workshop	T2-2005	T2-2005	100 %	On time: T2-2005
MS: second topical APD workshop	T3-2005	T3-2005	100 %	On time: T3-2005
ID: First structured list of intensity limits for booster synchrotrons and LHC	T2-2006	T2-2006	50%	Delayed: T3-2006

### N3.5 Significant Achievements

- Two specific [CARE-HHH](#) working groups were created in 2005: the first addressing issues such as accelerator physics and machine-detector interface aspects related to the upgrade of the LHC Interaction Regions, the second investigating an appropriate R&D programme for AC super-conducting magnets in view of an upgrade of the GSI and LHC injector complex, possibly with common magnet parameters, thus allowing to maximize the integrated luminosity.
- An intense effort was made for the dissemination of information and seven HHH workshops were organized in 2005, addressing magnet quench limits and LHC IR design, pulsed super-conducting magnets, connections with Fusion (ITER) and US-LARP, remote diagnostics and maintenance of beam instrumentation devices, as well as crystal collimation. Milestones were defined for future experimental studies to validate LHC luminosity upgrade scenarios.
- Several IR layout options were identified for the LHC luminosity upgrade, including a quadrupole-first layout based on Nb<sub>3</sub>Sn technology, a low-gradient dipole-first layout based on NbTi technology, an early beam separation scheme based on a “D0” dipole located a few metres away from the IP, and a flat beam option compatible with nominal LHC hardware. Alternative layouts, bunch spacings, beam-beam compensation and luminosity enhancement schemes are being rated in terms of technological and operational risks/advantages, in view of defining an LHC Upgrade baseline design possibly already by the end of 2006.
- HHH web repositories for [accelerator physics codes](#) and [LHC IR upgrade optics solutions](#) were set up. Possible optics, RF and collimation systems for an upgrade of the LHC injectors were investigated, including a new Super-PS and a 1 TeV Super-SPS.

### N3.6 List of all milestones and deliverables (D) during the reporting period

Work package	Title	Status	Planned (in months)	Achieved (in months)
WP1-AMT				
15	MS: AMT topical meeting on Insulation	100 %	15	15
16	ID: proceedings if the first AMT topical workshop on superconductors	100 %	15	15
17	ID: report on AMT organization and conductor development	80 %	12	18
19	MS: AMT topical meeting on Beam loss	100 %	15	15

	induced thermal effects			
W3-APD				
D	Code Web site database	100 %	24	18
48	MS: proceedings of the first topical APD workshop	100 %	18	18

NOTE: The development of the web-based database for SC cables and magnets has been slowed down. The main reasons of the delay are that the budget to hire a dedicated fellow was not yet available in T2-2005; later on, it turned out to be non-trivial to recruit an adequate candidate.

### N3.7 List of major meetings organized under HHH during the reporting period

Date	Title/subject of meeting workshop	Location	Number of attendees	Website address
14 Jan	1 <sup>st</sup> LUMIUP meeting	CERN (CH)	7	<a href="http://care-hhh.web.cern.ch/care-hhh/Meetings/LHCUG20050114.txt">http://care-hhh.web.cern.ch/care-hhh/Meetings/LHCUG20050114.txt</a>
2 Mar	CARE-HHH coordination meeting	CERN (CH)	5	<a href="http://care-hhh.web.cern.ch/care-hhh/Meetings/CAREHHHcoordinationmeeting02032005.txt">http://care-hhh.web.cern.ch/care-hhh/Meetings/CAREHHHcoordinationmeeting02032005.txt</a>
3–4 Mar	2 <sup>nd</sup> HHH-AMT workshop	CERN (CH)	80	<a href="http://amt.web.cern.ch/amt/events/workshops/beam_heat_2005/announcement.htm">http://amt.web.cern.ch/amt/events/workshops/beam_heat_2005/announcement.htm</a>
7–8 Mar	2 <sup>nd</sup> HHH-APD mini-workshop	CERN (CH)	About 80	<a href="http://care-hhh.web.cern.ch/CARE%2DHHH/CrystalCollimation/">http://care-hhh.web.cern.ch/CARE%2DHHH/CrystalCollimation/</a>
22-23 Mar	3 <sup>rd</sup> HHH-AMT workshop	CERN (CH)	32	<a href="http://at-hhh-amt.web.cern.ch/AT-HHH-AMT/">http://at-hhh-amt.web.cern.ch/AT-HHH-AMT/</a>
13 Apr	2 <sup>nd</sup> LUMIUP meeting	CERN (CH)	8	
29 Jul	HIP 2005	Elba Island (I)	80	<a href="http://care-hhh.web.cern.ch/CARE-HHH/LUMI-05/Organization/Arcidosso/LiteratureForLumi05.html">http://care-hhh.web.cern.ch/CARE-HHH/LUMI-05/Organization/Arcidosso/LiteratureForLumi05.html</a>
31 Aug–3 Sep	LHC-LUMI-05	Arcidosso (I)	40	<a href="http://care-hhh.web.cern.ch/CARE-HHH/LUMI-05/">http://care-hhh.web.cern.ch/CARE-HHH/LUMI-05/</a>
24 Oct	HHH coordination meeting	CERN (CH)	4	<a href="http://care-hhh.web.cern.ch/CARE-HHH/Meetings/CAREHHHcoordinationmeeting24102005.txt">http://care-hhh.web.cern.ch/CARE-HHH/Meetings/CAREHHHcoordinationmeeting24102005.txt</a>
26–28 Oct	ECOMAG 05	Frascati (I)	70	<a href="http://ecomag-05.web.cern.ch/ecomag-05/">http://ecomag-05.web.cern.ch/ecomag-05/</a>
6–7 Dec	HHH-ABI workshop	Hirschberg (DE)	About 20	<a href="http://adweb.desy.de/mdi/CARE/Hirschberg/ABI-Hirschberg.htm">http://adweb.desy.de/mdi/CARE/Hirschberg/ABI-Hirschberg.htm</a>
8–9 Dec	HHH-APD mini-workshop	CERN (CH)	10	<a href="http://care-crystalchanneling.web.cern.ch/care-crystalchanneling/">http://care-crystalchanneling.web.cern.ch/care-crystalchanneling/</a>

## 1.4 JOINT RESEARCH ACTIVITIES

### 1.4.1 JRA1: Superconducting Radio Frequency (SRF)

The list of participants and their implication in the SRF Work Packages (C: Coordination, X: Participation) is given in the table below. The overall management is done by DESY and CNRS-Orsay.

Number	Participant	WP1 M&C	WP2 ISCF	WP3 SCP	WP4 TFCP	WP5 SP	WP6 MA	WP7 COUP	WP8 TUN	WP9 LLRF	WP10 CIT	WP11 BD	Person- months
1	CEA					X			X		C	X	143.2
3	CNRS	C						C	X		X		164
	CNRS-IPNO								X				24
	CNRS-LAL	C						C	X		X		140
6	DESY	C	X	C		C	X			C			212 (36)
10	INFN		C	X	X	X	C		X			C	128.5 (73.7)
	INFN-LNF											C	32.3 (9,5)
	INFN-LNL		X	X		X	C						36.2 (24,2)
	INFN-Mi		C						X				30 (16)
	INFN-Ro2				X								30 (24)
12	TUL								C	X			72 (36)
13	IPJ		X		C								83 (12)
14	WUT-ISE									X			31.9 (22.3)
19	PSI									X			14

The aim of the JRA on Superconducting RF Technology is to improve the quality and performance of the superconducting test accelerator TTF (Tesla Test Facility), a unique test facility to explore operating conditions of a high gradient superconducting accelerator, at DESY. This installation combines an RF electron gun, 5 superconducting accelerating units, beam diagnostics and undulators for FEL operation.

The ultimate objectives of this research activity are: to increase the accelerating gradient from 25 to 35 MV/m; to increase the quality factor from  $5 \times 10^9$  to  $2 \times 10^{10}$ ; to improve the reliability, operating performance and availability of the superconducting accelerating system; to achieve a cost reduction of the SRF cavities and their associated components.

There continues to be a strong connection between the R&D activities in JRA-SRF and the European X-FEL and International Linear Collider projects. It seems likely that many of the results of the work from SRF will have a major impact on both these projects.

#### JRA1.1 Work Package 1: Management and Communication

##### JRA1.1.1 Use and Dissemination of knowledge

Communication is an important aspect of the JRA-SRF, both between participating institutes as well as with external institutes who share our interest in high gradient, low loss superconducting cavities. Contributions from JRA-SRF members were given to several conferences and meetings, the major ones being as follows:

- The 12<sup>th</sup> International Workshop on RF Superconductivity (Ithaca, NY)
- The SPIE International Conference on Optics and Opto-electronics (Warsaw).
- The 2005 United States Particle Accelerator Conference (Tennessee).
- The 2nd ILC (International Linear Collider) meeting (Snowmass),

Papers and talks were also presented at TESLA Technology Collaboration meetings in this reporting year as well as at the annual CARE meeting held at CERN in November. The impressive progress made in Work-Packages 8 (Tuners) and 9 (Low-level RF) earned the WP leaders the opportunity to give *highlight* talks at this meeting. The presentations can be found on the meeting WEB site.

### **JRA1.1.2 Meetings**

#### **SPIE Conference**

The SPIE conference, held in Warsaw, is particularly worth noting as an entire session was devoted by the organizers to CARE issues and several CARE-SRF participants were asked to make invited presentations within this session.

#### **Annual SRF Meeting**

In addition to the above conferences and meetings, the SRF JRA held their dedicated annual meeting at the INFN Legnaro laboratory. This meeting included an entire review of all work-packages and tasks therein. It was the opportunity for the external scientific advisory committee to review the program of work. Their findings can be found later within this report. What was clear from the Legnaro meeting is that, despite some delay in certain milestones / deliverables, the project has made enormous progress in the last twelve months. The technical summaries to be found in later sections bear witness to this.

### **JRA1.2 Work Package 2: Improved Standard Cavity Fabrication**

#### **JRA1.2.1 Reliability analysis**

The activity relative to the reliability is progressing with some delays, primarily due to the time consuming phase of information retrieval and analysis. Correlations between the cavity performance degradation, from the vertical test to the string behavior in the cryomodule, with the number of problems encountered during the assembly procedure have been highlighted. This indicates that a reduction in the number of problems during the cryomodule assembly would produce a reduction of this effect.

#### **JRA1.2.2 Improved component design**

An analysis of main ancillaries of SRF cavities has been done to highlight possible critical points in achieving both better performance and higher reliability for future large accelerator facilities such as the ILC (International Linear Collider). In February 2005, the milestone 2.2.1.3 was met with the delivery of the document “*Summary report on the status of art on ancillaries on the experience of various laboratories involved in SC RF*” (CARE-Note-2005-003-SRF).

Among the main ancillaries of a SRF cavity, cold flange connections play a crucial role and an improvement of their reliability is required for the future SRF accelerator structures where several thousand cold flanges will be used. Therefore, the reliability of the seal, the reduction of costs of flanges and seals, the decrease of seal assembly and tightening time, the shortening of the junction dimensions and the increase of the machine filling factor are key points.

A critical analysis of the TESLA beamline connection flanges at room and at cryogenic temperature, with dedicated experimental measurements and the development of a model for FEM analysis has been performed this year. Result obtained so far give information on their behavior, on the leak tightening limit etc. The main result, after the experimental validation of the model, is the possibility to study the joint behavior changing the compression force, the groove and seal geometry, the gasket material, etc. The milestone 2.2.1.14, -Final report for new components-, can be considered fulfilled with the delivery of the CARE Note “Final Reports for new components: Cold Flanges” (October 25, 2005).

A description of the activities performed for the analysis of the TESLA beam line flange behavior is presented.

During the flange assembly, the torque of the bolts and nuts produces the load on the sealing gasket. The force applied on the seal depends on the friction coefficients between bolts, nuts and washers. In order to decouple the applied load from the friction coefficient, we mount, in a controlled way, the seal onto a material testing machine (Instron, maximum load 200 kN) measuring the leak rate and the mechanical properties of the gasket. Two different aluminium alloys have been used for the gaskets: Al5754 (also called AlMg3) and Al6060. The alloy compositions have been verified by ICP spectrophotometry.

Some pictures and a sketch of the measurement set up are shown in Figure JRA1.2.1.

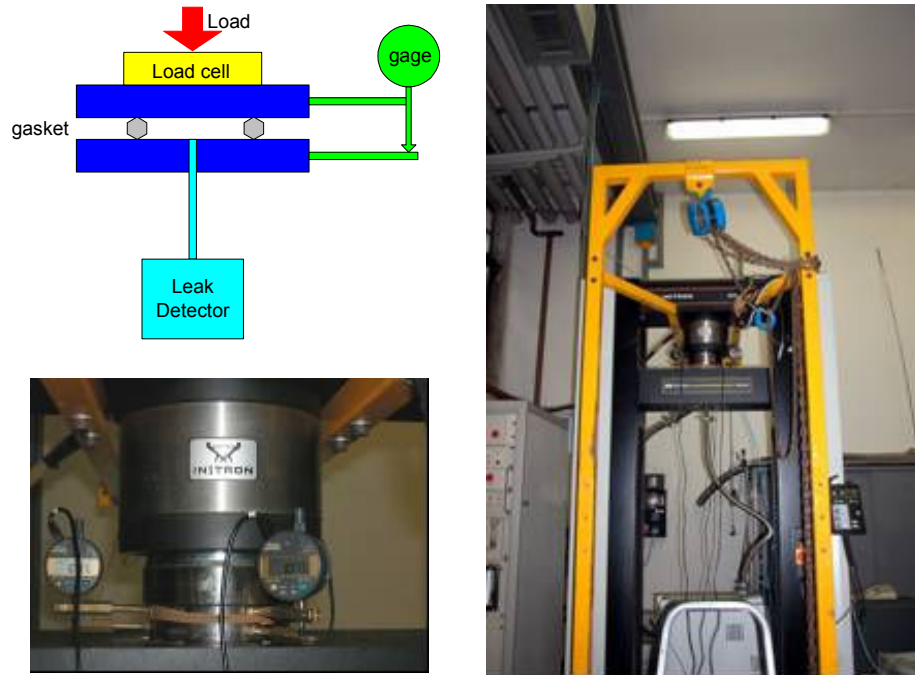


Figure JRA1.2.1: Sketch and pictures of the apparatus used for compression and leak tests of TTF flanges and gaskets (maximum load 200 kN). The leak detector is connected to the bottom flange.

The mechanical properties of the gasket are summarized in the displacement vs. load graphs shown in Figure JRA1.2.2. Due to the different material, G18 and G20 (Al5754) gaskets show, for the same load, larger compression.

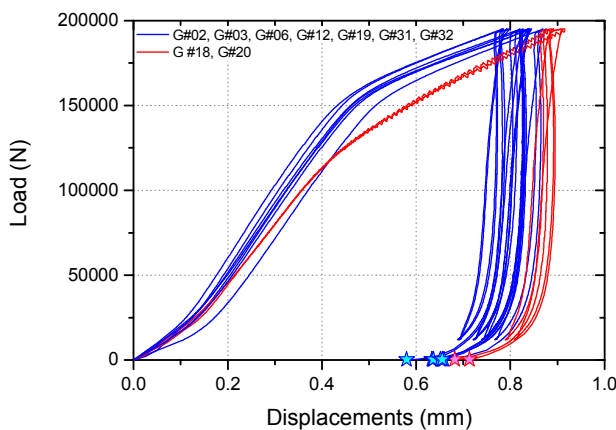


Figure JRA1.2.2: Comparison of different seals during the load test

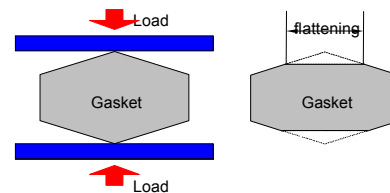


Figure JRA1.2.3: Gasket flattening



Usually the linear force and the pressure applied to the seal are the parameters that have to be carefully investigated to characterize the quality of a seal. For this purpose, we perform a series of tests to evaluate the gasket flattening (see Figure JRA1.2.3) as a function of the applied load. Using these data we calculate the pressure applied to the gasket.

Figure JRA1.2.4 shows typical data for the two aluminium alloys considered. The gasket flattening increases linearly with the load and hence the pressure stays constant. At about 30 kN, the tightness of the seal is generated (the pressure on the seal is about 560 MPa).

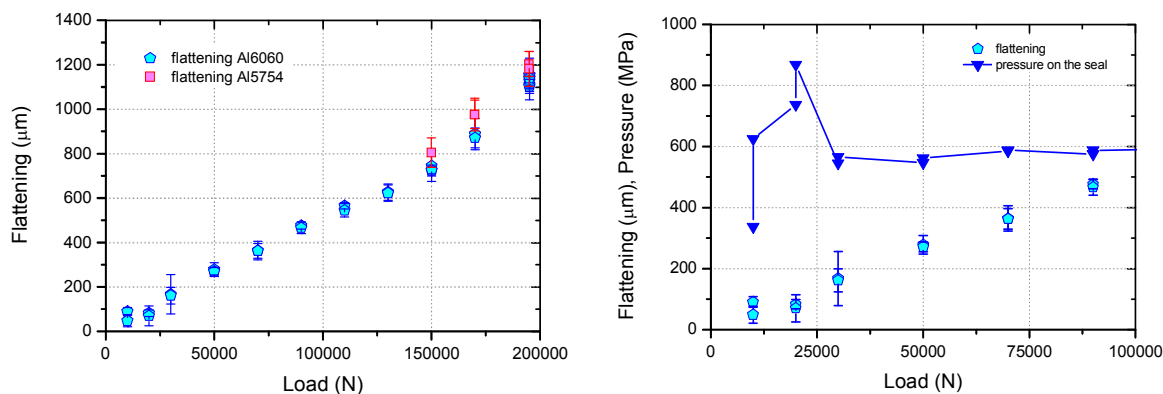


Figure JRA1.2.4: Gasket flattening and pressure on the seal.

During compression measurements, leak tests have been performed in order to study the generation of the seal and the behavior of the leak rate vs. the load applied to the flanges. The leak test starts right at the beginning of the seal generation, and, in these conditions, the leak rate is quite high: this produces, in some measurements, a strong He background signal, whose subtraction reflects some uncertainty in the leak test. As an example the leak behavior during a compression test is shown (gasket G #03 - Al6060) in Figure JRA1.2.5.

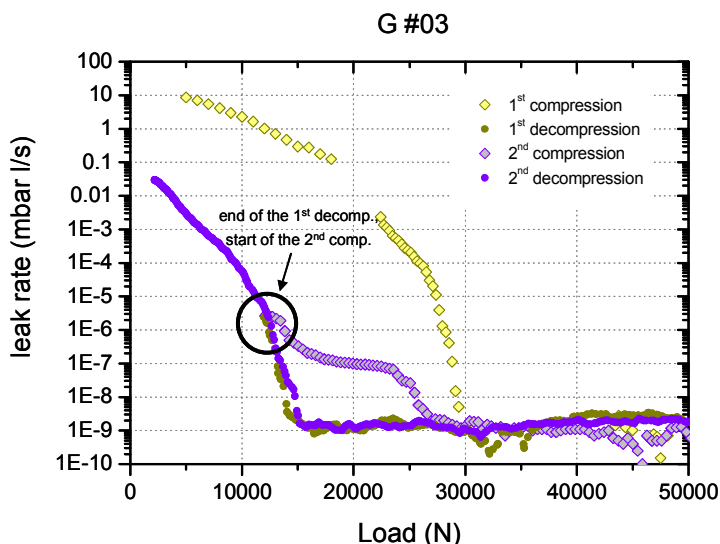


Figure JRA1.2.5: leak rate measurement during compression and decompression test.

The results obtained using the mechanical test machine, have been used to predict the behavior of the seal (flange/gasket system) under standard operation, where bolts and nuts are used. Figure JRA1.2.6 shows the experimental setup for these measurements.





Figure JRA1.2.6: Bolt tightening with torque meter and liquid nitrogen temperature leak test.

By comparing the measurement of the permanent squashing produced during the Instron tests with the one obtained from the manual tightening of the flange, we were able to obtain the torque-compression - force relation and therefore the friction coefficient between the stainless steel bolts and CuNiSi nuts in our particular conditions (see Figure JRA1.2.7).

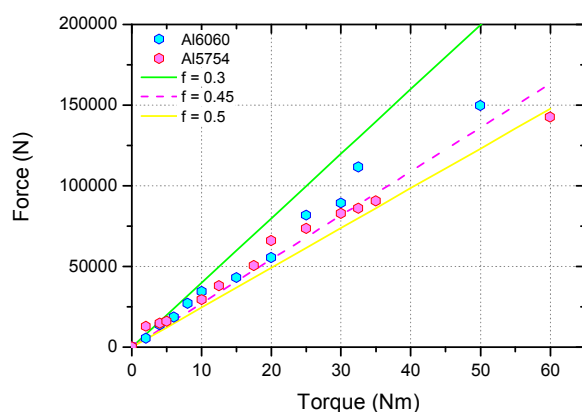


Figure JRA1.2.7: experimental relation between torque and compression force.

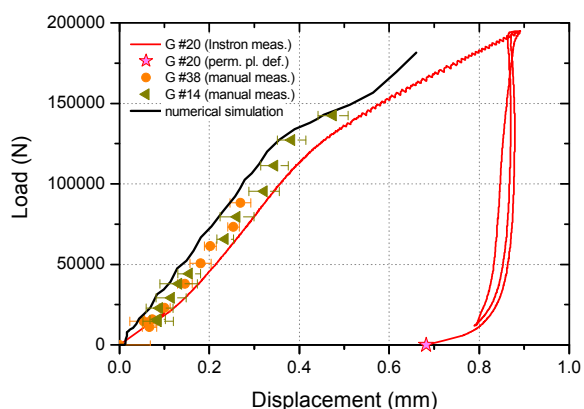


Figure JRA1.2.8: Comparison between the numerical model results and the experimental data.

The test results allowed us to validate a finite element model of the connection (see Figure JRA1.2.8). This can be used for future study and optimization of a new seal geometry and material.

### JRA1.2.3 EB welding

The UHV-Motor has been delivered and tested for UHV-capability. The rate of desorption after 100 h pumping is  $5 \cdot 10^{-6}$  mbar-l/s. We judge the residual gas analysis as good. The construction for the mechanical conversion is in the final phase.

In the first stage of expansion the y-drive will be operated by hand. The integration in the PLC will be the next step.

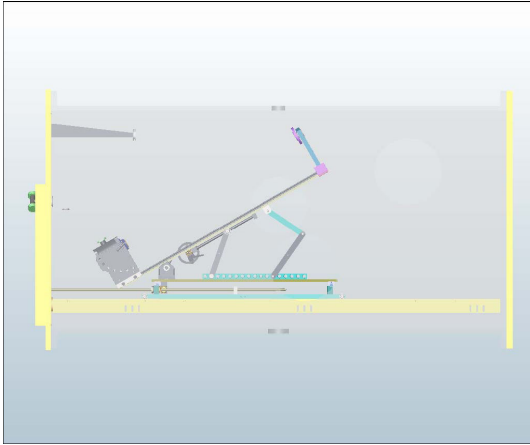


Figure JRA1.2.9: Tilt fixture for 45°-seams

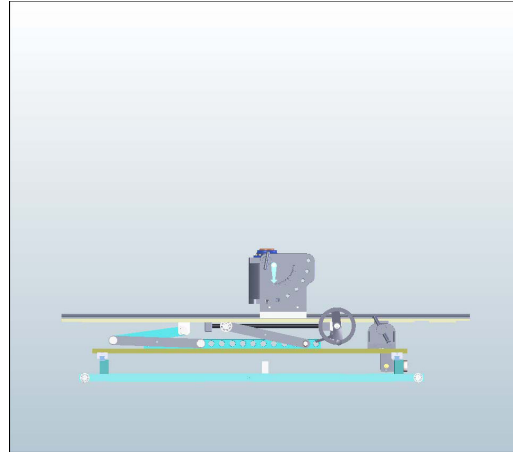


Figure JRA1.2.10: Carousel operation for front seams

### JRA1.2.4 Overall Progress of Work Package 2

The following table highlights the progress of work planned in the year 2005 for the Work Package WP2 by listing the lowest level subtasks of the SRF detailed implementation plan.

N°	Task Name	MS, Deliverable	Contractor	% aschlo	2005				2006	
					1.Q05	2.Q05	3.Q05	4.Q05	1.Q06	2.Q06
<b>2</b>	<b>WP 2 IMPROVED STANDARD CAVITY FABRICATION</b>			<b>35%</b>						
<b>2.1</b>	<b>Reliability Analysis</b>		<b>DESY</b>	<b>62%</b>						
2.1.1	Review of data bank cavity fabrication		DESY	100%						
2.1.2	Review of data bank cavity treatment		DESY	100%						
2.1.3	Review of data bank cavity VT performance		DESY	100%						
2.1.4	Review of data bank string assembly		DESY	100%						
2.1.5	Review of data bank string performance		DESY	27%						
2.1.6	Establish correlations		DESY	10%						
2.1.7	<b>Final report on reliability issue</b>	<b>Final Report</b>	DESY	0%						
<b>2.2</b>	<b>Improved component design</b>			<b>32%</b>						
<b>2.2.1</b>	<b>Documentation retrieving</b>		<b>INFM-Mi</b>	<b>51%</b>						
2.2.1.1	Start up meetings		INFM-Mi	100%						
2.2.1.2	Access and study of Jlab, DESY, LLAN, KEK experience		INFM-Mi	100%						
2.2.1.3	<b>Summary report on the status of the art on ancillaries</b>	<b>Summary Report</b>	INFM-Mi	100%						
2.2.1.4	Sealing material and shape design		INFM-Mi	100%						
2.2.1.5	Flange preliminary design		INFM-Mi	100%						
2.2.1.6	Material and geometric compatibility		INFM-Mi	100%						
2.2.1.7	Final assembly design		INFM-Mi	50%						
2.2.1.8	End plate preliminary design		INFM-Mi	50%						
2.2.1.9	<b>Report about new design for components</b>	<b>Design Report</b>	INFM-Mi	100%						
2.2.1.10	Stiffness optimization		INFM-Mi	40%						
2.2.1.11	Manufacturing procedure analysis		INFM-Mi	30%						
2.2.1.12	Final assembly design		INFM-Mi	20%						
2.2.1.13	Other ancillaries design		INFM-Mi	6%						
2.2.1.14	<b>Final Report for new components</b>	<b>Report</b>	INFM-Mi	40%						
<b>2.2.2</b>	<b>Review of criticality in welding procedures</b>		<b>INFM-Mi</b>	<b>9%</b>						
2.2.2.1	Review of available parameters on vendor welding machine		INFM-Mi	13%						
2.2.2.2	Definition of prototype requirements for tests		INFM-Mi	10%						
2.2.2.3	Welding test on specimens		INFM-Mi	0%						
2.2.2.4	Analysis of the results		INFM-Mi	0%						
2.2.2.5	<b>Report about welding parameters</b>	<b>Report</b>	INFM-Mi	0%						
<b>2.2.3</b>	<b>Finalize new component design</b>		<b>INFM-Mi</b>	<b>0%</b>						
2.2.3.1	Do drawings		INFM-Mi	0%						
2.2.3.2	<b>New components design finished</b>	<b>Design report</b>	INFM-Mi	0%						
<b>2.2.4</b>	<b>Finalize new cavity design</b>		<b>INFM-Mi</b>	<b>0%</b>						
2.2.4.1	Make drawings		INFM-Mi	0%						
2.2.4.2	<b>New cavity design finished</b>	<b>Design report</b>	INFM-Mi	0%						
<b>2.2.5</b>	<b>Fabrication of new cavity</b>		<b>INFM-Mi</b>	<b>0%</b>						
2.2.5.1	Fabrication		INFM-Mi	0%						
2.2.5.2	<b>New cavity finished</b>	<b>Cavity Prototype</b>	INFM-Mi	0%						
<b>2.3</b>	<b>EB welding</b>		<b>DESY</b>	<b>38%</b>						
<b>2.3.1</b>	<b>Design tooling</b>		<b>DESY</b>	<b>100%</b>						
2.3.1.1	Tools for flange welding		DESY	100%						
2.3.1.2	Tools for pipe welding		DESY	100%						
2.3.1.3	Tools for stiffening rings		DESY	100%						
2.3.1.4	Tools for single cell welding		DESY	100%						
2.3.1.5	Tools for 9-cells		DESY	100%						
2.3.1.6	<b>Tools design finished</b>	<b>Design report</b>	DESY	100%						
<b>2.3.2</b>	<b>Tools production</b>		<b>DESY</b>	<b>74%</b>						
2.3.2.1	Tools for flange welding		DESY	100%						
2.3.2.2	Tools for pipe welding		DESY	100%						
2.3.2.3	Tools for stiffening rings		DESY	100%						
2.3.2.4	Tools for single cell welding		DESY	100%						
2.3.2.5	Tools for 9-cells		DESY	20%						
2.3.2.6	<b>Tools fabrication finished</b>	<b>Tools Ready</b>	DESY	15%						
<b>2.3.3</b>	<b>Welding</b>		<b>DESY</b>	<b>19%</b>						
2.3.3.1	Commissioning welding machine		DESY	100%						
2.3.3.2	Test welding		DESY	85%						
2.3.3.3	<b>Start production welding of components</b>	<b>Commissioning</b>	DESY	10%						
2.3.3.4	Single cell welding		DESY	10%						
2.3.3.5	Multicell welding		DESY	3%						
2.3.3.6	<b>Welding of prototypes of components finished</b>	<b>Prototype</b>	DESY	5%						

### JRA1.3 Work Package 3: Seamless Cavity Production

#### JRA1.3.1: Seamless cavities by spinning

The spinning machine is finished and is working perfectly. The new set of rollers still need to be done, but as the material used for rollers is very expensive, they will be fabricated after the end of the machine commissioning. This will allow us to do some modifications to them on the basis of the acquired experience.

The new machine is equipped with a more powerful hydraulic station, in order to achieve higher values of pressure between the lathe tailstock and headstock. This enables us to get a higher wall thickness at the cavity iris. Indeed, for long time, a thin wall at the cavity iris has represented a problem for seamless fabrication.

Since the machine is more powerful, all the spinning parameters must be changed. Higher values of the pressure applied to the rollers, and higher compression pressure along the axis of the cavity require a lower number of spinning steps. Indeed, through the standard procedure developed before, we improved the plastic deformation process increasing the number of spinning steps. However, the higher the number of spinning steps, the more the material hardens, increasing the risk of fracture propagations. The evaluation of spinning parameters is a long procedure and much attention must be paid to the preparation of samples.

The support system and turning mechanism, while swaging the cavity, is working but it is only temporary, since we are evaluating the possibility of using different rollers with a cavity-roller contact area that is much higher than the standard one. Of course, this will dramatically change the spinning parameters.

In short, the milestone of a drawing spinning machine was already reached some time ago; the milestone of having the spinning machine ready is almost achieved apart from the commissioning, as the assembly of the machine is already finished but is still requires modifications. The evaluation of spinning parameters has only started and this will be the longest operation of task 3.1.



Figure JRA1.3.1: Phase of the double turret necking process during the spinning parameter definition action.

### JRA1.3.2: Seamless cavity production by hydroforming

The tube necking machine was successfully constructed according to schedule. A photograph and a schematic are shown in Fig.JRA1.3.2 and Fig.JRA1.3.3.

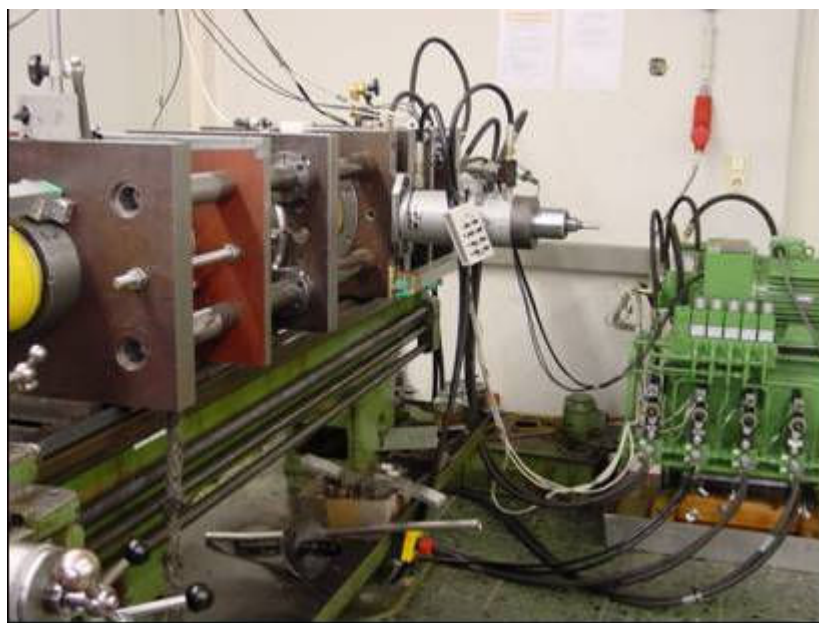


Figure JRA1.3.2: View of the tube necking machine

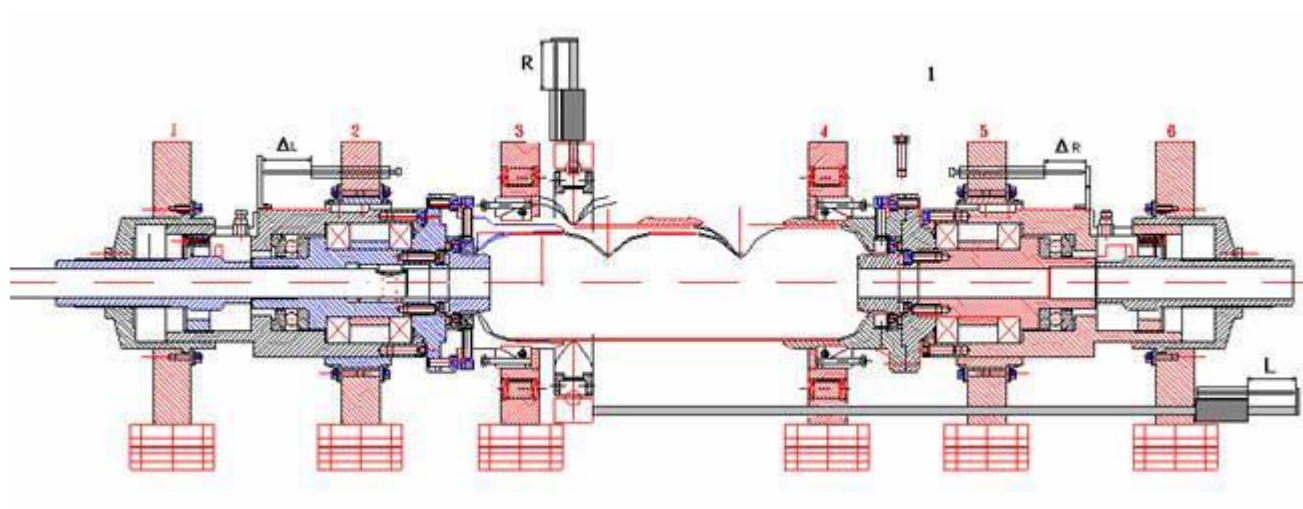


Figure JRA1.3.3. Schematic of the tube necking machine (cross section)

The machine is foreseen for necking of Nb and NbCu tubes with internal diameters (ID) of 130 and 150 mm. The diameter should be reduced to 75.6 or 83.6 mm.

The machine consists of seven transversally oriented plates. Several hydraulic cylinders are fixed on the plates:

- Left and right cylinder for the application of axial pressure. Cylinder parameters: diameter 150 mm, stroke 125 mm, pressure 200 bar
- Cylinder for movement of the central plate. Cylinder parameters: diameter 100 mm, stroke 600 mm, pressure 200 bar
- Cylinder for movement of the instrument. Cylinder parameters: diameter 100 mm, stroke 45 mm, pressure 200 bar



The plates are connected to each other using four bars of diameter 50 mm. The bars are fixed on end plates. All cylinders are equipped with position and pressure sensors.

The necking machine is fixed to the lathe. The tube rotation is caused by the lathe mechanism. The machine is PC controlled. Two options for the software have been developed for the two types of tube necking (see Appendix 1 and 2):

Option 1: Necking of the tube end to diameter of 75.6 or 83.6 mm (Software Neckend)

Option 2: Necking of the tube middle (iris) to diameter of 75.6 mm (software Neckiris)

The first experiments have shown that the machine functions correctly. The necking of the Cu tubes both at the tube end and at the tube middle (iris) was successfully implemented (see figure JRA1.3.4). The optimization of the necking parameters is going on.



Figure JRA1.3.4: Necking at the tube end and tube middle implemented by necking machine.



Figure JRA1.3.5: View of the hydroforming machine

In the frame of the task 3.2 the hydroforming machine was provided with new moulds for fabrication of multi cells and also with a water hydraulic system for the internal pressure in

the tube and with an oil hydraulic system for the cylinder movements. The developed computer control system for the hydroforming allows the hydraulic expansion in stepwise as well as in continuous regime. A view of the machine can be seen in Fig. JRA1.3.5. The construction of the hydroforming machine is finished and first tests for commissioning of the machine are ongoing.

The multi cell seamless cavities are planned to be fabricated starting from both the tubes with inside diameters of ID=130 mm and ID=150 mm.

The main principles for the production of seamless niobium tubes from hydroforming are developed in co-operation with scientific institutes and industrial companies.



Figure JRA1.3.6 Seamless niobium tubes for cavity fabrication by hydroforming

The seamless tubes are built starting from the thick sheet having already a rather small and uniform grain structure. Tubes are produced by combination of spinning and flow forming (Fig. JRA1.3.6). This combination allows one to improve the surface and significantly reduce wall thickness variations. Flow forming was done in the forward direction (Fig. JRA1.3). This method permits the production of tubes with wall thickness tolerances of  $\pm 0.15$  mm, which should be sufficient for subsequent hydroforming.

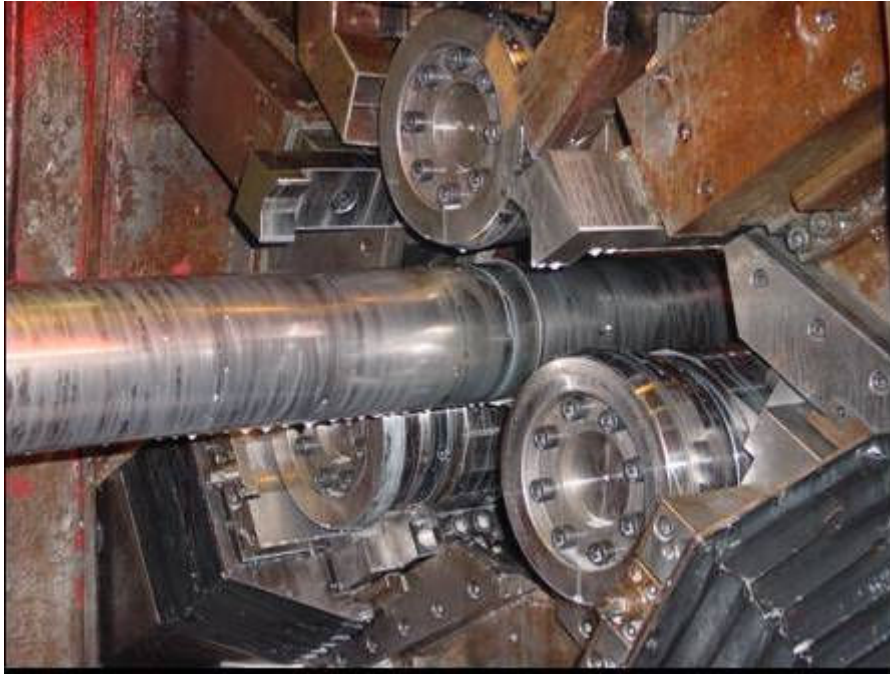


Figure JRA1.3.7: Flow forming of the seamless niobium tubes



### JRA1.3.3 Overall Progress of Work Package 3

The following table highlights the progress of work planned in the year 2005 for the Work Package WP3 by listing the lowest level subtasks of the SRF detailed implementation plan.

N°	Task Name	MS, Deliverable	Contractor	% aschlo	2005				2006	
					1.Q05	2.Q05	3.Q05	4.Q05	1.Q06	2.Q06
<b>3</b>	<b>WP3 SEAMLESS CAVITY PRODUCTION</b>			<b>64%</b>						
<b>3.1</b>	<b>Seamless by spinning</b>		<b>INFN-LNL</b>	<b>41%</b>						
<b>3.1.1</b>	<b>Design spinning machine</b>		<b>INFN-LNL</b>	<b>100%</b>						
3.1.1.1	Drawings of the matrices		INFN-LNL	100%						
3.1.1.2	Drawings of the support system		INFN-LNL	100%						
3.1.1.3	<b>Drawings of spinning machine finished</b>	<b>Design repor</b>	INFN-LNL	100%						
<b>3.1.2</b>	<b>Fabrication of spinning machine</b>		<b>INFN-LNL</b>	<b>76%</b>						
3.1.2.1	Fabrication of machine parts		INFN-LNL	100%						
3.1.2.2	Software for the machine		INFN-LNL	100%						
3.1.2.3	Assembly of machine		INFN-LNL	50%						
3.1.2.4	Commissioning of the machine		INFN-LNL	10%						
3.1.2.5	<b>Spinning machine ready</b>	<b>Commissionin</b>	INFN-LNL	10%						
<b>3.1.3</b>	<b>Evaluation of spinning parameters</b>		<b>INFN-LNL</b>	<b>31%</b>						
3.1.3.1	Drawings of the support system and turning mechanism		INFN-LNL	10%						
3.1.3.2	Drawings of the necking mechanism		INFN-LNL	40%						
3.1.3.3	Fabrication of the tube necking machine		INFN-LNL	40%						
3.1.3.4	Commissioning of the machine		INFN-LNL	10%						
3.1.3.5	<b>Spinning parameters defined</b>	<b>Design Repor</b>	INFN-LNL	20%						
<b>3.1.4</b>	<b>Spinning of 1-cell cavities</b>		<b>INFN-LNL</b>	<b>0%</b>						
3.1.4.1	Material and fabrication of bulk Nb test tubes		INFN-LNL	0%						
3.1.4.2	Material and fabrication of bimetallic NiCu test tubes		INFN-LNL	0%						
3.1.4.3	<b>1-cell spinning parameters defined</b>		INFN-LNL	0%						
<b>3.1.5</b>	<b>Extension of spinning apparatus to multicells</b>		<b>INFN-LNL</b>	<b>0%</b>						
3.1.5.1	Computer simulation of the necking		INFN-LNL	0%						
3.1.5.2	<b>Start of Multi-cell spinning</b>	<b>Start spinning</b>	INFN-LNL	10%						
<b>3.1.6</b>	<b>Spinning of multi-cell cavities</b>		<b>INFN-LNL</b>	<b>0%</b>						
3.1.6.1	Computer simulation of the spinning		INFN-LNL	0%						
3.1.6.2	Spinning of bulk Nb 9-cell cavities		INFN-LNL	0%						
3.1.6.3	<b>Parameters of multi-cell spinning defined</b>	<b>Design repor</b>	INFN-LNL	0%						
<b>3.1.7</b>	<b>Series production of multi-cell cavities</b>		<b>INFN-LNL</b>	<b>0%</b>						
3.1.7.1	Spinning		INFN-LNL	0%						
3.1.7.2	<b>Multi-cell cavities finished</b>	<b>Final Report, Cavity</b>	INFN-LNL	0%						
<b>3.2</b>	<b>Seamless by hydroforming</b>		<b>DESY</b>	<b>75%</b>						
<b>3.2.1</b>	<b>Design hydro forming machine</b>		<b>DESY</b>	<b>100%</b>						
3.2.1.1	Drawings of the matrices		DESY	100%						
3.2.1.2	Drawings of the support system		DESY	100%						
3.2.1.3	<b>Drawings matrix &amp; support finished</b>	<b>Design repor</b>	DESY	100%						
<b>3.2.2</b>	<b>Construction of hydro forming machine</b>		<b>DESY</b>	<b>100%</b>						
3.2.2.1	Hydraulic for machine		DESY	100%						
3.2.2.2	Software for the machine		DESY	100%						
3.2.2.3	Machine fabrication		DESY	100%						
3.2.2.4	Commissioning of the machine		DESY	100%						
3.2.2.5	<b>Hydro forming machine ready</b>	<b>Commissionin</b>	DESY	100%						
<b>3.2.3</b>	<b>Construction of tube necking machine</b>		<b>DESY</b>	<b>100%</b>						
3.2.3.1	Drawings of the support system and turning mechanism		DESY	100%						
3.2.3.2	Drawings of the necking mechanism		DESY	100%						
3.2.3.3	Fabrication of the tube necking machine		DESY	100%						
3.2.3.4	Software for the tube necking machine		DESY	100%						
3.2.3.5	<b>Construction tube necking machine finished</b>	<b>Design repor</b>	DESY	100%						
<b>3.2.4</b>	<b>Development of seamless tubes for 9-cell cavities</b>		<b>DESY</b>	<b>100%</b>						
3.2.4.1	Material and fabrication of bulk Nb test tubes		DESY	100%						
3.2.4.2	Material and fabrication of bimetallic NiCu test tubes		DESY	100%						
3.2.4.3	<b>Seamless tubes ready</b>	<b>Design repor</b>	DESY	100%						
<b>3.2.5</b>	<b>Development of tube necking</b>		<b>DESY</b>	<b>32%</b>						
3.2.5.1	Computer simulation of the necking		DESY	60%						
3.2.5.2	Experiments on tube necking at iris		DESY	0%						
3.2.5.3	<b>Tube necking machine operational</b>	<b>Commissionin</b>	DESY	0%						
<b>3.2.6</b>	<b>Hydro forming of seamless cavities</b>		<b>DESY</b>	<b>24%</b>						
3.2.6.1	Computer simulation of the hydro forming		DESY	40%						
3.2.6.2	Hydro forming of bulk Nb 9-cell cavities		DESY	0%						
3.2.6.3	<b>Hydro formed 9-cell cavities ready</b>	<b>Cavity Prototypi</b>	DESY	0%						

## JRA1.4 Work Package 4: Thin Film Cavity Production

### JRA1.4.1 Linear arc cathode coating

Task WP4.1 is focused on the development of an UHV arc system with the linear (cylindrical) cathode configuration. The principal scheme of the cavity coating by means of the linear (cylindrical) arc discharge and the modified linear-arc facility, which was put into operation in 2004, is presented in Fig.JRA1.4.1.

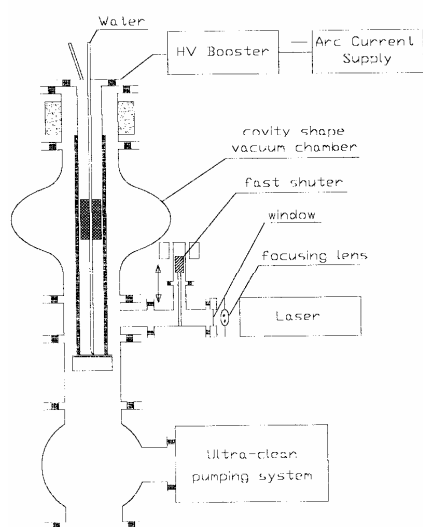


Figure JRA1.4.1: Scheme of the linear-arc UHV system and modified facility at IPJ (Swierk).

In 2005 studies of the arc-current reduction and stabilization were performed with the use of a stainless-steel chamber of shape and dimensions similar to an original single TESLA RF-cell. That chamber was equipped with two main flanges, which are used as connections to the UHV pumping stand (at the bottom) and a magnet driving system (at the top); and four side-on (radial) diagnostic ports distributed symmetrically in the central symmetry plane of the cell, where the distance between the cathode and the wall of the cell is the largest.

Since the cleanliness of deposition processes plays a crucial role during the formation of thin superconducting niobium layers, in order to achieve high-quality superconducting films particular attention was paid to the initial vacuum conditions. The residual gas pressure, and particularly the partial pressures of water, nitrogen, oxygen, CO<sub>2</sub>, hydro-carbons etc., were reduced by the construction and operation of the linear-arc facility according to the requirements of UHV technology. The vacuum pumping stand was constructed as a completely oil-free system and the whole facility was equipped with appropriate heaters and supply units for baking. Due to the baking it was possible to achieve a final pressure of  $1.5 \times 10^{-10}$  mbar, and to reduce the amount of impurities, as shown in Fig.JRA1.4.2.

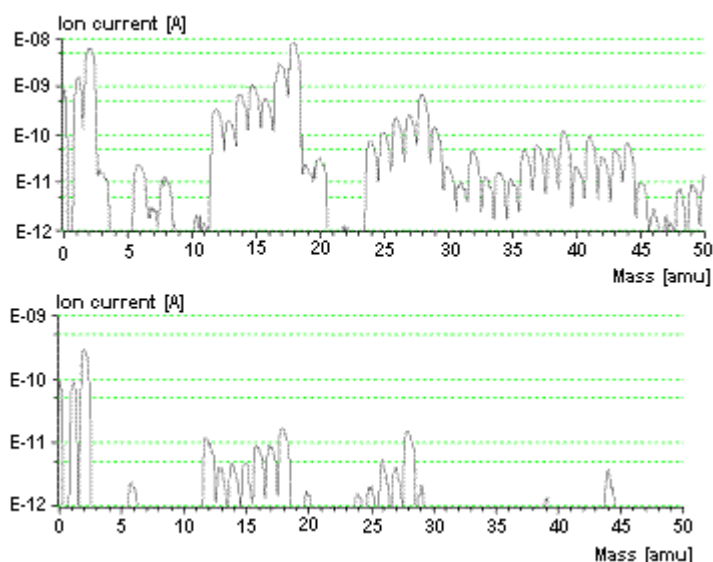


Figure JRA1.4.2: Typical RGA mass-spectra recorded within the linear-arc facility, as recorded before and after 24-hour baking at 150 °C.

Studies of the current reduction and stabilization have been performed by means of a new power supply unit and a special solid-magnet system, which was placed inside the cathode tube in order to drive the arc discharge along the cathode surface. These studies are complete (according to the updated schedule), and stable discharges can be produced at a current reduced to about 70 A. Measurements performed with the ion-current collector, placed at a distance corresponding to the cell wall, have shown that, for the investigated operational conditions, the ion-current density amounts to 50-80 mA/cm<sup>2</sup>.

The optimization of the powering system was performed and the apparatus for single cell coating was put into operation in July 2005. The parameters of this power-supply are as follows: maximum current  $I_{\max} = 350$  A, booster voltage  $V_b = 200$  V, PC control, and DC or pulsed-operation. A general view of a new DC/pulse supply unit is presented in Fig.JRA1.4.3.



Figure JRA1.4.3: new DC/pulse power-supply for the linear-arc facility.

In order to make the linear-arc facility operational for single-cavity coating, two TESLA-type cavities made of pure copper have been prepared by means of EB welding. They have been equipped with standard flanges and installed at the modified UHV linear-arc facility, as shown in Fig.JRA1.4.4.

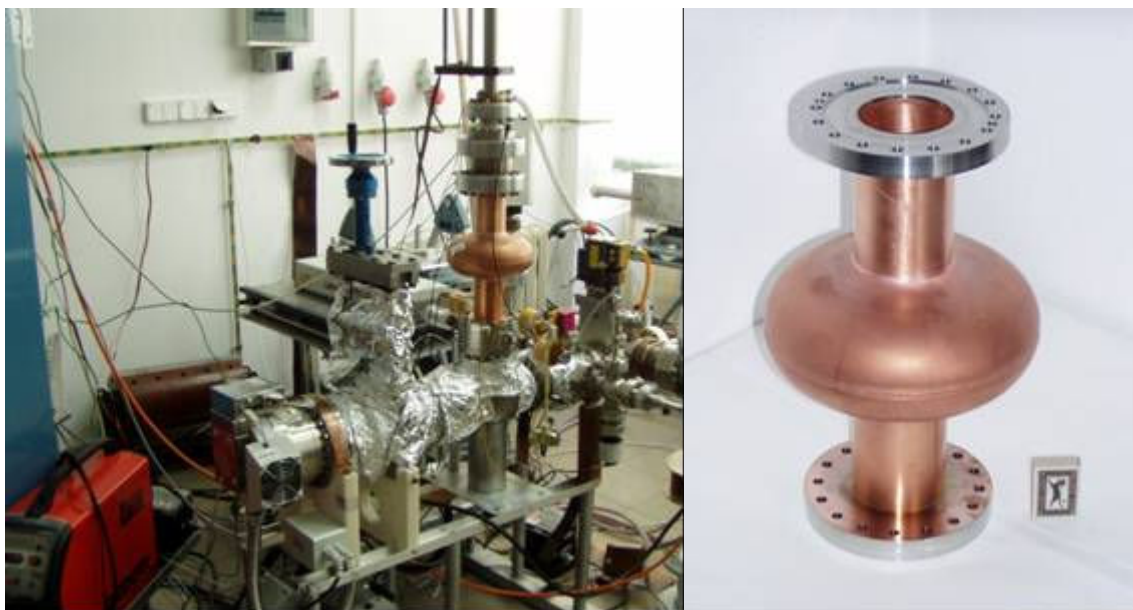


Figure JRA1.4.4: Single copper-cavity with end flanges and the modified UHV linear-arc system during laboratory tests of the single-cavity coating.

The temporal behavior of the discharge current in the UHV linear-arc facility without magnetic filtering was studied. The maximum arc current amounted to about 100 A, and the period of the cathode-spot motion (around the cylindrical cathode) was found to be 20 ms. Oscillogrammes of the arc current were recorded, as shown in Fig.JRA1.4.5.

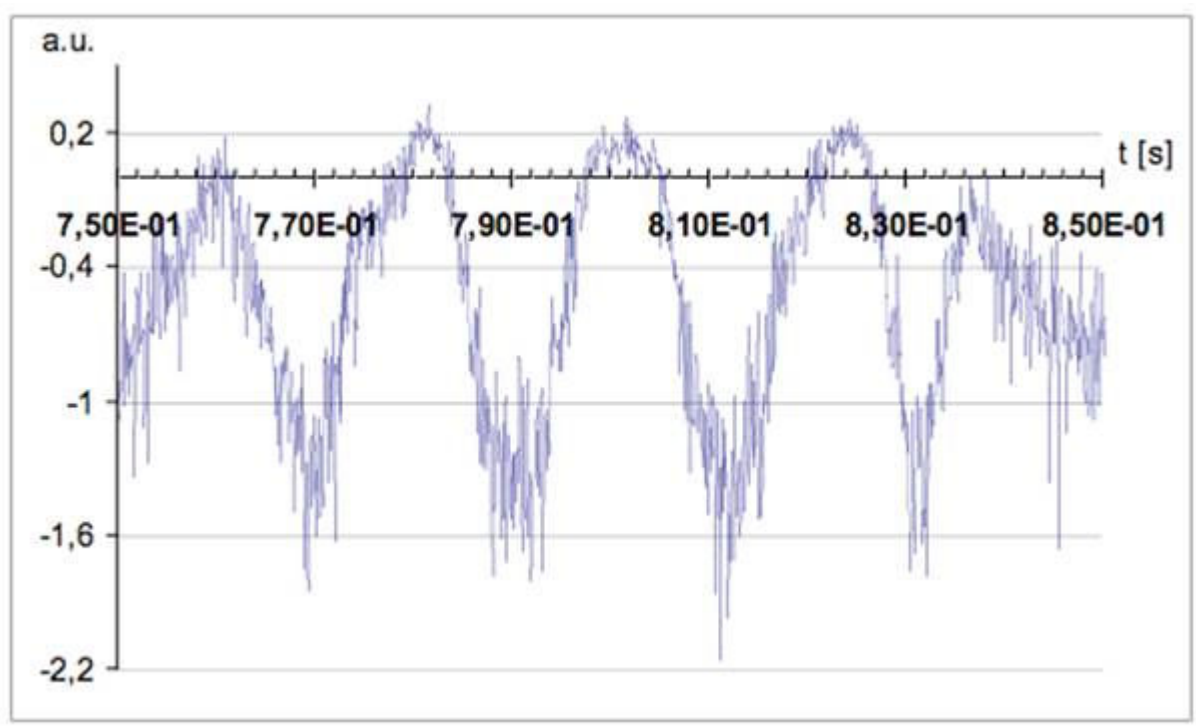


Fig.JRA1.4.5: Waveforms of the discharge current, as recorded during laboratory tests of the UHV linear-arc facility.

In order to perform coating of single cells a special arc-driving system, equipped with a miniature permanent magnet, was designed and manufactured at IPJ. A magnetic field, which is produced by the permanent magnet placed inside the niobium cathode tube, can stabilize the arc discharge and focus it on the cathode surface near the magnet position. The construction facilitates the controlled motion of the arc discharge along the z-axis and the coating of the

inner surface of an RF-cavity more uniformly. A general view of the top part of the magnet drive system is shown in Fig.JRA1.4.6.



Figure JRA1.4.6: Top part of the magnet-drive system used in the modified UHV linear arc facility.

Using the equipment described above, the single cell copper-cavities (taken from a TESLA test-bed) have been coated without micro-droplet filtering. After the coating, these cavities were cut along the symmetry axis in order to perform an analysis of the inner surfaces. A general view of the cut cavity is shown in Fig.JRA1.4.7.



Figure JRA1.4.7: Two parts of the coated single-cell, which was cut in order to perform an analysis of the inner surfaces.

Several samples were cut out of the Nb-coated surface and an analysis of their surfaces was performed by means of SEM, as shown in Fig.JRA1.4.8.



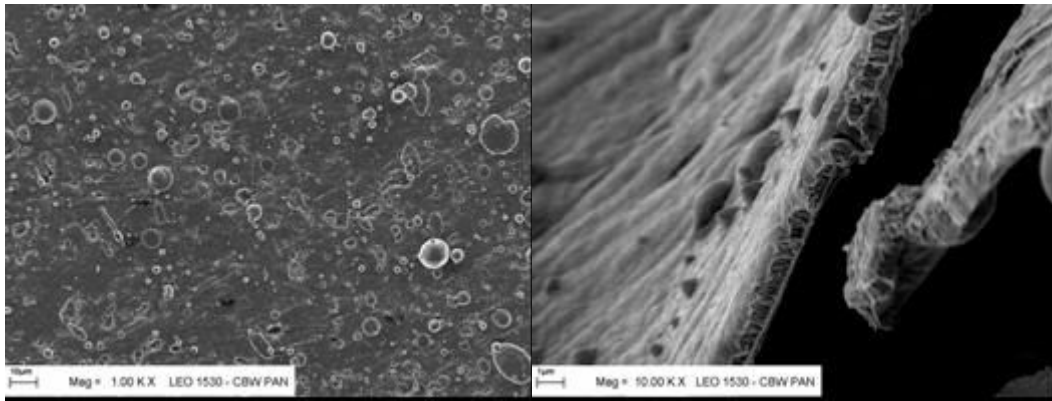


Figure JRA1.4.8: SEM pictures showing a relatively large population of the deposited micro-droplets (left), and the edge and thickness of the deposited niobium layer (right).

For comparison, several samples of pure sapphire were also coated within the UHV linear-arc facility under similar experimental conditions, and they were analyzed with the same SEM, as shown in Fig.JRA1.4.9.

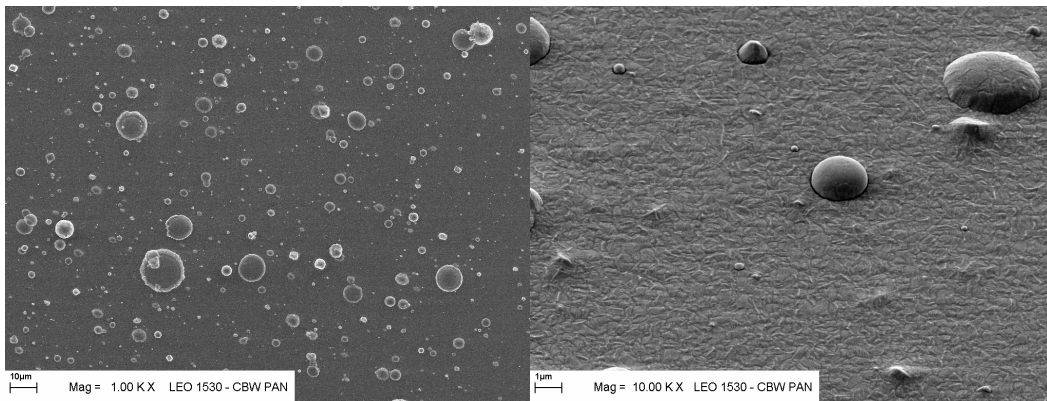


Figure JRA1.4.9: SEM pictures showing the population of the deposited micro-droplets (left), as well as the structure of the niobium layer and shapes of the micro-droplets (right).

An analysis of the micro-droplets deposited upon the sapphire samples was performed within the frame of the IPJ-Tor Vergata University collaboration, and some results are presented in Fig.JRA1.4.10.

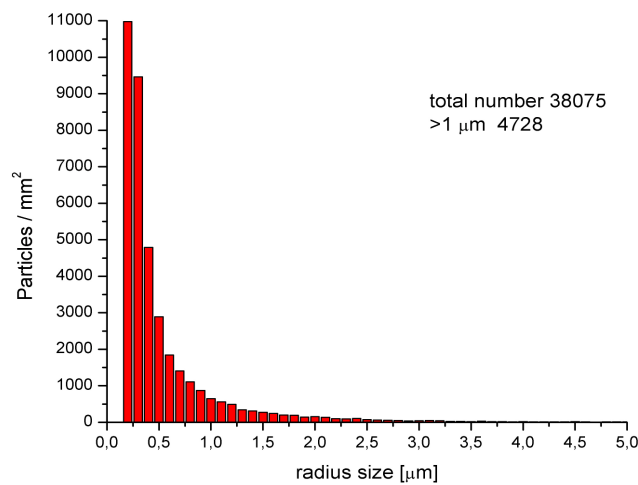


Figure JRA1.4.10. Histograms of the micro-droplet population, as measured upon the sapphire sample coated within the UHV linear-arc facility.

In order to reduce the number of micro-droplets within the linear-arc facility, a special cylindrical magnetic filter was designed and constructed. It consisted of a set of thin copper

tubes distributed symmetrically around the cylindrical surface and joined at the ends by special connectors. This construction enables an appropriate magnetizing-current and cooling-water flow to be realized. Since the cylindrical magnetic filter is a new concept, it requires extensive theoretical studies and experimental tests. Model computations of the magnetic field distribution have been performed for different configurations. An example is shown in Fig.JRA1.4.11.

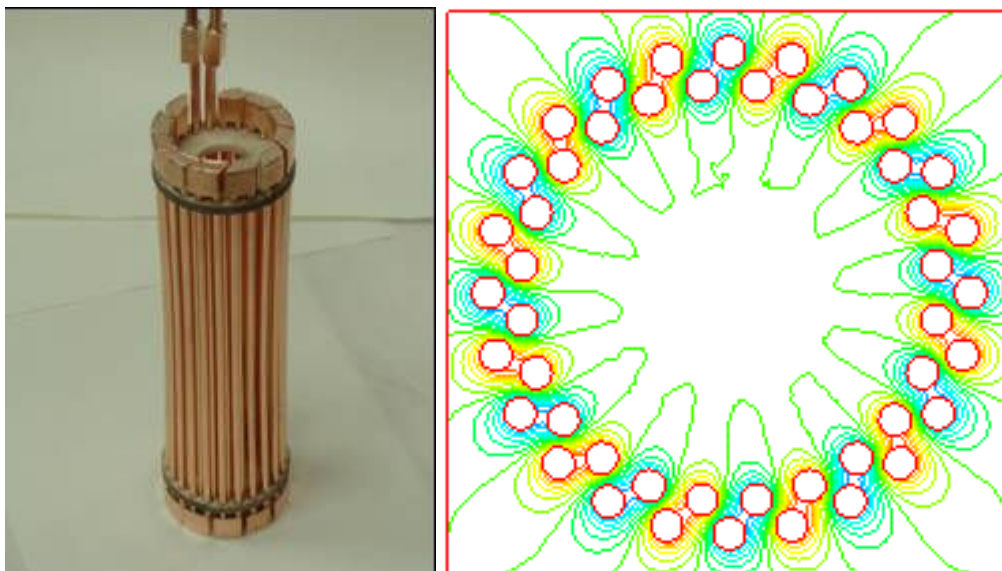


Figure JRA1.4.11: General view of the cylindrical magnetic filter and the corresponding distribution of magnetic field lines in the horizontal cross-section.

Preliminary tests of the cylindrical magnetic filter have been performed within an auxiliary experimental stand. The vacuum tightness, cooling efficiency and resistance of the filter to arc discharges, were investigated. It was demonstrated that the prototype cylindrical filter can be used under the required experimental conditions, as shown in Fig.JRA1.4.12.



Figure JRA1.4.12: Picture of the cylindrical magnetic filter and an additional anode after the exploitation tests.

The ion current density, as measured by means of the ion collector placed at a distance of 7.4 cm from the filter surface, amounted to 10 mA/cm<sup>2</sup> only. It means that the application of the cylindrical filter requires further studies in order to solve all construction problems (the design, the selection of materials, manufacturing technique, etc.) as well as some operational problems (the ignition of arc, the resistance of the system, etc...) .



Further tests of the single-cavity coating (even without any filtering) should be performed with original cavities, which should be delivered from the partner laboratories (e.g. DESY or INFN-Legnaro) as early as possible.

#### JRA1.4.2 Planar-Arc Cathode Coating

Task WP4.2 is focused on the development of an UHV cathodic arc-system in the planar cathode configuration. The principle scheme of a planar arc discharge system for coating of samples and a photograph of the actual, un-filtered system presently in operation, are shown in Fig.JRA1.4.13.

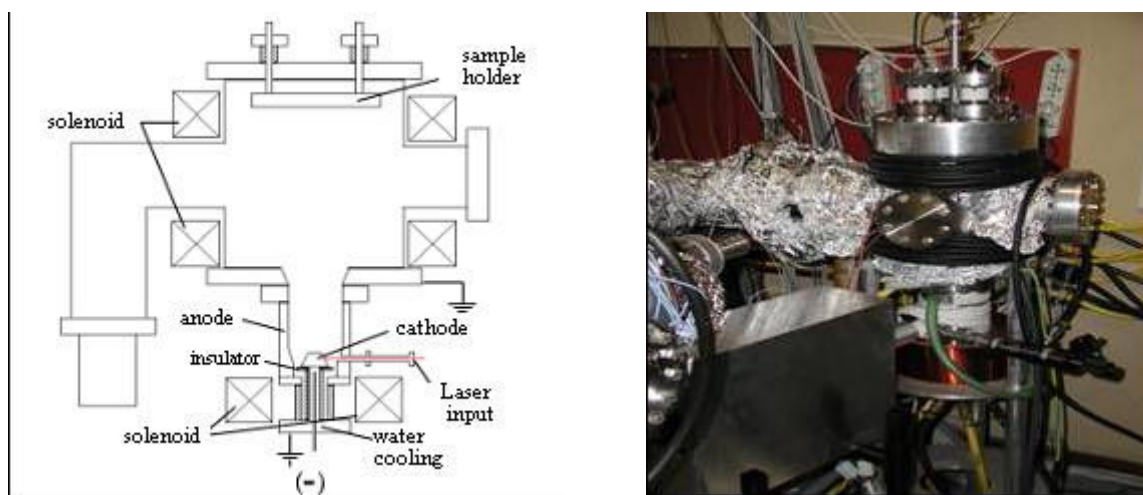


Figure JRA1.4.13: Scheme of the linear-arc UHV system and modified facility in Rome.

The present non-filtered system is equipped with coils to focus the plasma ion stream and with a new laser for triggering the arc discharge. A second planar-arc facility, equipped with an ion energy analyzer (on loan from CERN) and a magnetic macro-particle filter of the Aksenov type (L-type), is shown in Fig.JRA1.4.14.

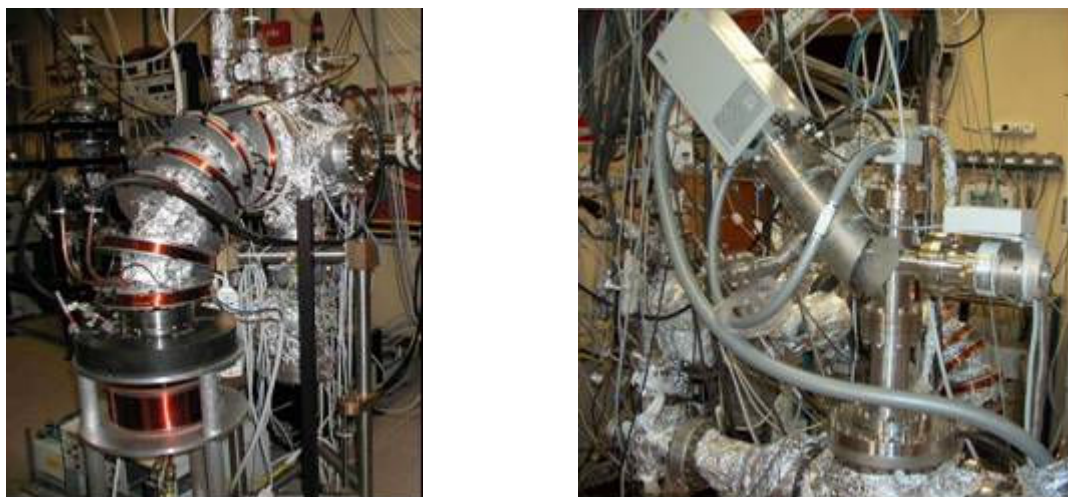


Figure JRA1.4.14: Ion energy analyzer (left) and the magnetic filter (right), as installed upon the second planar-arc facility, which was put in operation in 2005.

In 2005 an important task was the upgrading of the magnetic filter, with the aim of improving both the particle rejection and the deposition rate, by improving the spatial distribution of magnetic field lines. Different T-type filters have been designed at IPJ and

constructed both in Rome and in Swierk. Examples of the magnetic field distribution computations performed in Swierk are presented in Fig.JRA1.4.15.

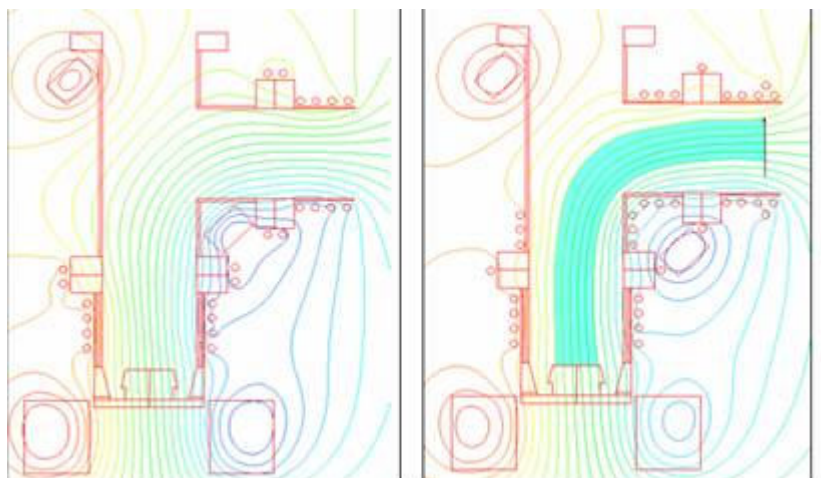


Figure JRA1.4.15: Distributions of magnetic field lines within the filter channel depend strongly on the configuration of coils and values of magnetizing currents.

Based on the model computations, a new magnetic filter of the T-type has been designed and is being fabricated. It is better cooled, so as to tolerate higher arc-currents, and its magnetic field configuration should allow for better plasma transport and therefore for a higher deposition rate and an improved uniformity of the deposited layers. The filter shape should also lead to improved macro-particle (micro-droplet) rejection.

A planar, un-filtered system version was also designed, fabricated and put into operation in 2005, to study deposition on a cavity-shaped substrate. It is presently used to study the problems on such a substrate, in particular how to obtain, inside it, a uniform thickness film. The system's stainless-steel vacuum chamber consists of two separable parts, whose shape is close to that of a TESLA-type cavity half cell, equipped with a set of sample holders located at different positions, as shown in Fig.JRA1.4.16.



Figure JRA1.4.16: View of the unfiltered planar-arc facility for the single-cell deposition (left) and a picture of the inner surface of the upper half-cell with sample holders (right).

Fig.JRA1.4.17 shows, as an example, the measured ion currents on samples as a function of their position on the chamber surface, for different magnetic field configurations.

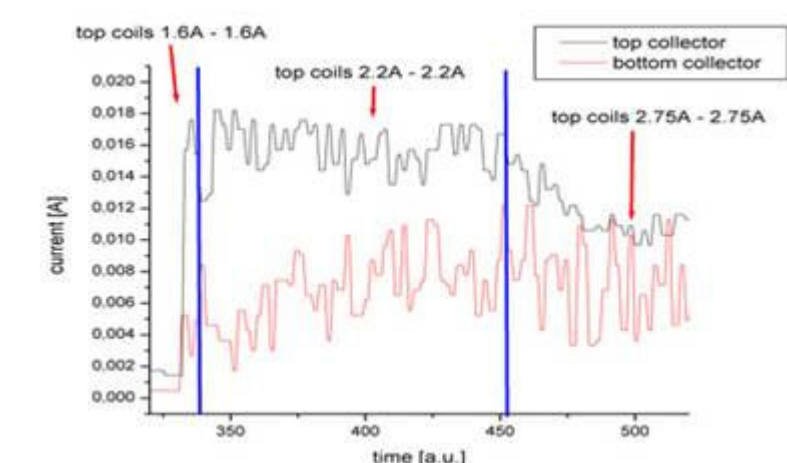


Figure JRA1.4.17. Changes of the ion current measured for different collectors and magnetic fields.

In order to improve the operation of all planar arc devices new automatic control systems were implemented: a laser control panel, shown in Fig.JRA1.4.18,

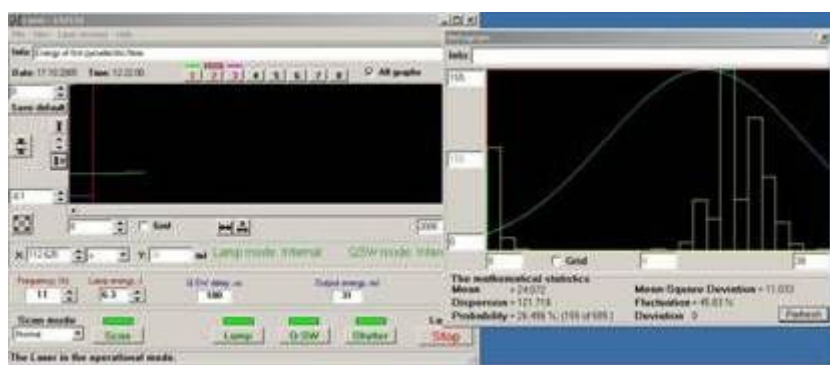


Figure JRA1.4.18: Laser control-panel.

and computer-controlled arc ignition electronics allowing automatic recovery after extinction, as shown in Fig.JRA1.4.19.



Figure JRA1.4.19: Example of arc current values recorded during operation showing automatic arc recovery.

According to the updated program of task 4.2 on sample characterization, samples coated under different conditions were studied. The subtask concerning the characterization of Nb-coated sapphire samples from the UHV planar-arc facility was performed by measuring their residual resistivity ratio (RRR), critical temperature ( $T_c$ ) and critical current ( $J_c$ ) using an inductive method. The RRR values of Nb films on sapphire samples kept close to room temperature, typically ranged from 20 to 50, as reported in a paper published in *Superconducting Science and Technology* **18** (2005).

Typical measured critical temperatures and critical current densities of early UHV arc deposited Nb film samples are shown in Fig.JRA1.4.20.

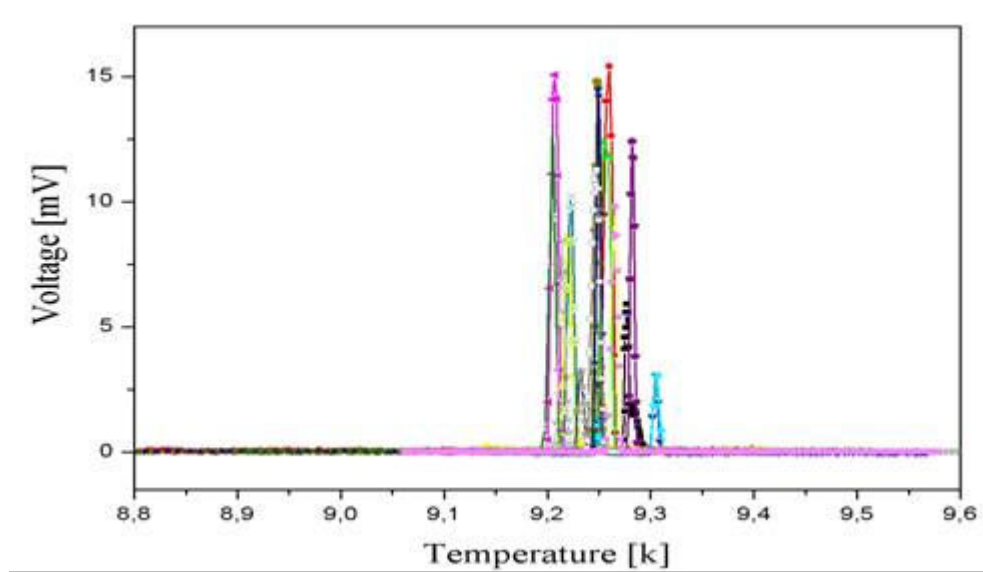


Figure JRA1.4.20:  $T_c$  measurements on various samples

The measured  $T_c$  values, close to those of bulk Nb, were an indication that stresses in the film are relatively low while the narrow transition widths ( $<0.02$  K) suggested that the deposited Nb-films are uniform and clean.

A summary report on the quality of UHV planar-arc Nb coating (the 2005 milestone) was prepared and delivered together with the CARE/JRA1 Quarter Report 2/2005. According to this report the critical temperature ( $T_c$ ), transition width ( $\Delta T_c$ ) and surface current density ( $J_c$ ) values of our best film samples are close to those of bulk Nb, i.e.  $T_c = (9.26 \pm 0.03)$  K,  $\Delta T_c \approx 0.02$  K and  $J_c = 3 \times 10^7$  A/cm<sup>2</sup>. An example is shown in Fig.JRA1.4.21.

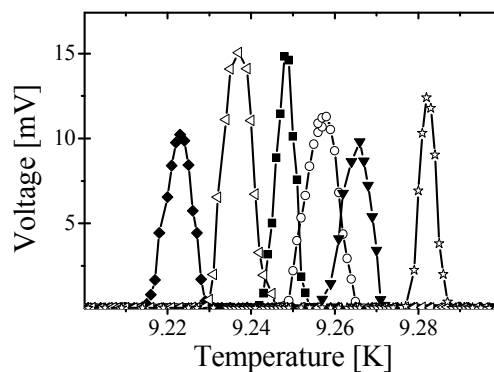


Figure JRA1.4.21: Measurement of the critical temperature  $T_c$  of the Nb-coated sample

The structure of Nb films was also analyzed using X-ray diffraction, atomic force microscopy and SEM. The lattice parameter resulting from X-ray diffraction spectra, collected using Cu-K radiation with filtered  $K_\beta$  line in the  $\theta$ - $2\theta$  configuration, ranged from 0.3306 to 0.3318 nm (close to 0.3306 nm of the bulk Nb), which again is an indication of low stresses. Atomic Force Microscopy pictures of films on copper showed an average Nb grain size of about 200 nm, and a film roughness comparable to that of the Cu substrate. The roughness of films deposited on sapphire substrates was instead much smaller. In some cases the growth of columnar structures of about 1.5  $\mu$ m in height, e.g. at the bottom and walls of micro-craters left by larger micro-droplets, was observed (see Annex 1 to CARE/JRA1 Quarter Report 2/2005). The most important result was the demonstration that the UHV-arc Nb-coated



samples show the same type of behavior as bulk Nb, and that the Nb-layers obtained with magnetic filtering appear to be the best ones.

Detailed 3D-profilometry on unfiltered and filtered Nb films samples deposited on sapphire substrates are being performed in the framework of a collaboration with Jefferson Laboratory, USA to study the efficiency of our present magnetic filter. A very first result is shown in Fig. JRA1.4.22: while on the unfiltered sample one finds  $\approx 10$  large signals, clearly to be attributed to Nb droplets, over the explored area, on the filtered sample only a few very small signals – to be better classified - are seen.

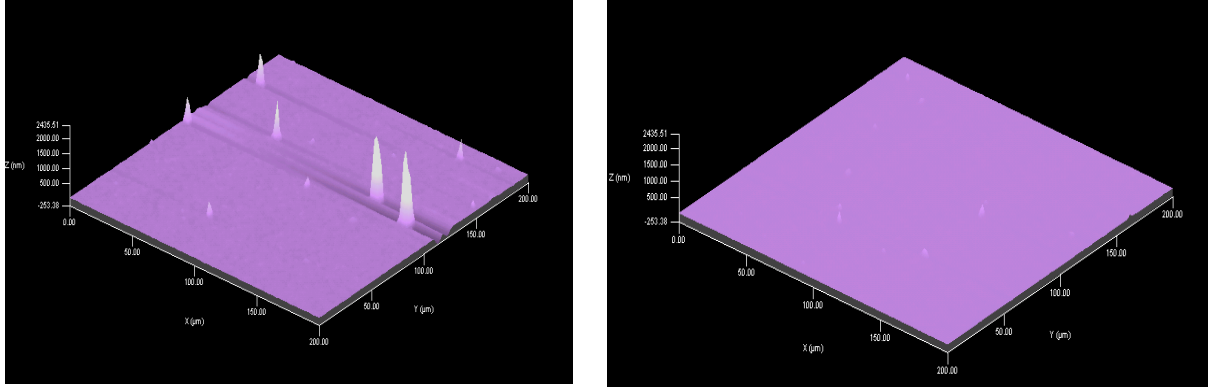


Figure JRA1.4.22: Profile-diagrams of unfiltered- and filters-samples of the 200  $\mu\text{m}$  x 200  $\mu\text{m}$  size (courtesy of A. Wu, Jefferson Lab).

Low field RF measurements were also performed on (small) sapphire coated samples by our collaborators at INFN-Napoli. The film RF surface impedance  $Z_s(T, H)$  was measured as a function of temperature, using the 22 GHz resonant Cu cavity shown in Fig.JRA1.4.23.

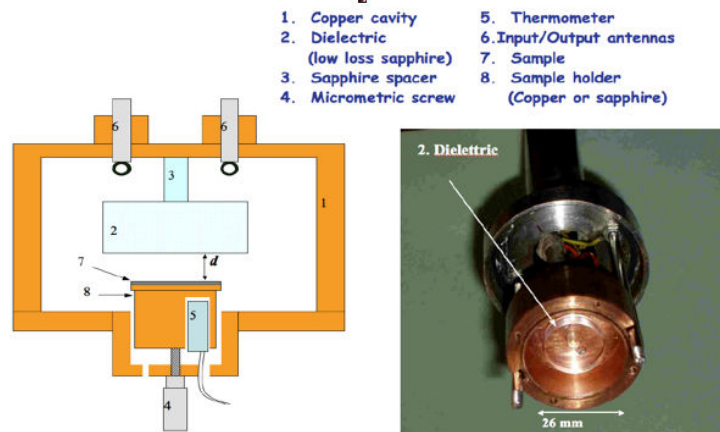


Figure JRA1.4.23: Schematic drawing of the system and view of the (opened-up) cavity used for low-field RF measurements at INFN-Napoli .

Results (Fig.JRA1.4.24) show that, within the explored parameter range, the filtered film behaves like the bulk Nb reference sample to within the experimental errors.

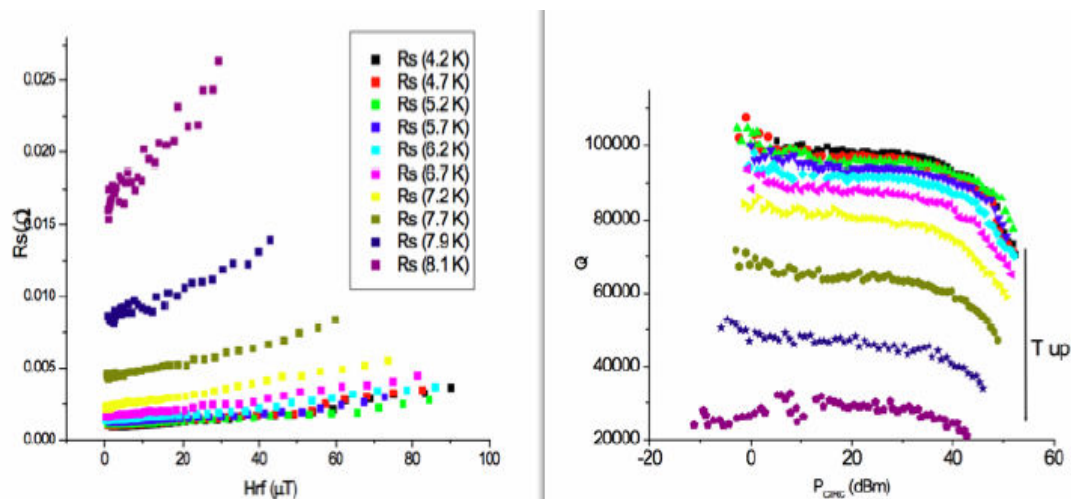


Figure JRA1.4.24: Residual resistance and Q values of the investigated samples as a function of temperature.

The subtask concerning the characterization of Nb films on copper was performed through collaboration with researchers at Cornell University, USA, who carried out high field measurements on our (large) samples (Fig. JRA1.4.25). The first high-field RF measurements of filtered Nb-coated, large Cu-samples were performed at 6 GHz, and the results were reported by A. Romanenko and H. Padamsee at SRF-2005. The quality factor (Q) of the best sample, which sustained a magnetic field value of 300 Oe, possibly limited by the host cavity quench, was comparable, within the errors, to the present limit value ( $\approx 3 \times 10^8$ ) of the host cavity.

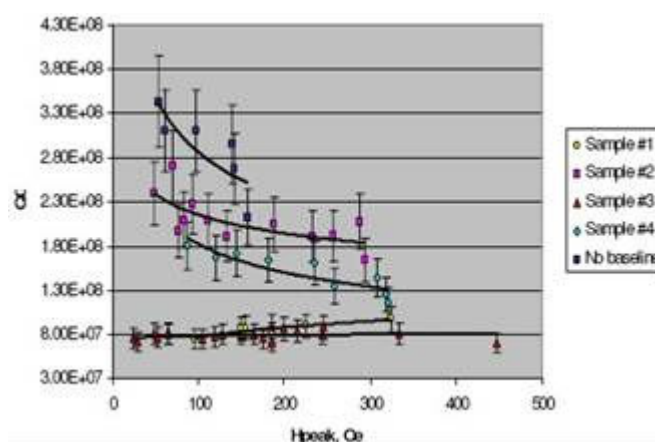


Figure JRA1.4.25: One of the  $\approx 10$  cm diameter Nb coated Cu samples measured in Cornell (left) and measurements of the  $Q_0$  versus  $H_{\text{peak}}$  of four such samples.

As regards studies of other HTC superconducting coatings, the UHV-arc apparatus to study the production of NbN films, equipped with a system to finely control the gas flow rate into the arc chamber, has been assembled. Commissioning has been started but is being delayed because of problems with arc stability as a function of the gas pressure, which need further investigation.

#### JRA1.4.3 Overall Progress of Work Package 4

The following table highlights the progress of work planned in the year 2005 for the Work Package WP4 by listing the lowest level subtasks of the SRF detailed implementation plan.

A. ACTIVITY REPORT

N°	Task Name	MS, Deliverable	Contractor	%	2005				2006	
					1.Q05	2.Q05	3.Q05	4.Q05	1.Q06	2.Q06
<b>4</b>	<b>WP4 THIN FILM CAVITY PRODUCTION</b>			<b>55%</b>						
<b>4.1</b>	<b>Linear-arc cathode coating</b>		<b>IPJ</b>	<b>56%</b>						
<b>4.1.1</b>	<b>Installation &amp; commissioning of coating apparatus</b>		<b>IPJ</b>	<b>73%</b>						
4.1.1.1	Modification of a prototype facility for single cells		IPJ	100%						
4.1.1.2	Optimization of a triggering system		IPJ	100%						
4.1.1.3	<b>Prototype facility ready</b>	<b>Commissionin</b>	IPJ	100%						
4.1.1.4	Study of arc current reduction and stabilization		IPJ	100%						
4.1.1.5	Optimization of powering system		IPJ	100%						
4.1.1.6	<b>Coating apparatus operational</b>	<b>Apparatus read</b>	IPJ	100%						
4.1.1.7	<b>Coating single cells</b>		<b>IPJ</b>	<b>59%</b>						
4.1.1.7.1	Coating of single cells w without micro droplet filtering		IPJ	70%						
4.1.1.7.2	Design and construction of a micro droplet filter sys		IPJ	70%						
4.1.1.7.3	<b>Droplet filter ready</b>	<b>Hardware read</b>	IPJ	25%						
4.1.1.7.4	Coating of single cell w ith micro droplet filtering		IPJ	0%						
<b>4.1.2</b>	<b>Coating multi-cell</b>		<b>IPJ</b>	<b>0%</b>						
4.1.2.1	Design and commissioning		IPJ	0%						
4.1.2.2	First multicell coating		IPJ	0%						
<b>4.2</b>	<b>Planar-arc cathode coating</b>		<b>INFN-Ro2</b>	<b>53%</b>						
<b>4.2.1</b>	<b>Modification of a planar-arc &amp; trigger system</b>		<b>INFN-Ro2</b>	<b>100%</b>						
4.2.1.1	Modification		INFN-Ro2	100%						
4.2.1.2	Optimization of the laser triggering system		INFN-Ro2	100%						
4.2.1.3	<b>Planar arc system fully tested</b>	<b>Status Repor</b>	INFN-Ro2	100%						
<b>4.2.2</b>	<b>Routine Operation of planar arc system</b>		<b>INFN-Ro2</b>	<b>92%</b>						
4.2.2.1	Characterization of samples coated at different conditions		INFN-Ro2	95%						
4.2.2.2	Characterization of Nb-coated sapphire samples		INFN-Ro2	90%						
4.2.2.3	Characterization of Nb-coated copper samples		INFN-Ro2	90%						
4.2.2.4	<b>Summary report on quality of planar arc coating</b>	<b>Status Report</b>	INFN-Ro2	100%						
<b>4.2.3</b>	<b>Studies of other HTC superconducting coating</b>		<b>INFN-Ro2</b>	<b>25%</b>						
4.2.3.1	Study of superconducting properties		INFN-Ro2	25%						
4.2.3.2	<b>Report on quality of superconducting properties</b>	<b>Final Report</b>	INFN-Ro2	0%						

## JRA1.5 Work Package 5: Surface Preparation

### JRA1.5.1 Electropolishing (EP) on single cells

#### JRA1.5.1.1 EP on Samples

Work on samples has allowed us to identify the key role of fluorine ion concentration in the ageing of the EP solution, as well as in the prevention of the production of solid sulphur. We have been able to quantify the ageing of the polishing solution and to identify conditions for safer use. Attempts to enhance the HF concentration showed that even if this produces a longer lifetime and less sulphur production, unfortunately this approach will not be applicable to cavities due to its Cathode-Anode distance sensitivity. Several tracks are now explored like enhancing F- content via a salt instead of fluoric acid, or changing the viscosing agent. As lifetime and pollution of the EP solution is certainly a key issue toward a gain of reproducibility, we shall pursue this program.

#### JRA1.5.1.2 Single cell cavities: completed

The cavities have been delivered and have been tested (standard RF measurement).

#### JRA1.5.1.3 Build EP chemistry for single cell cavities

Construction of lab hoods has been completed, and acquisition system has been studied and developed. Security authorizations have been obtained and commissioning is underway (still test with water). First cavity treatment is expected for the beginning of next year.





Figure JRA1.5.1: EP set-up for single cells

All the results from the last two years will be gathered in a global report (namely Deliverable n°8, 2004), which will be produced at the beginning of next year.

#### **JRA1.5.2 Electropolishing (EP) on multi-cells**

The EP set up is running continuously. First information on ageing of system components is available. Due to this information some re-design is necessary and shifts the expected end dates of task 5.2.

Data on acid ageing are available now and a system for online control and to replenish the acid by adding HF acid automatically is under development. This part of the WP is complete. The parameters for continuous runs are fixed and quality control is established. Some modifications and additional quality control steps are needed due to new results showing up during the last 100 h of operation. This will lead to an extension of the work on bath ageing. The software for electrode optimization is ordered and installed on a DESY computer. Training of personal is in progress and parameters for input data of the software are ordered. A laser roughness instrument is under installation at the University of Wuppertal. This system looks to be the relevant one for the measurements. The roughness measurement system will be tested on samples. Industrialization of the EP will be made in parallel to the study of industrialization of the electro-polishing funded under the XFEL preparation investigations.

#### *Remarks*

For the realization of an industrial prototype of the electro-polishing system, the time foreseen under this work package is insufficient to build up and operate such a system.

#### *Discussion needed:*

At present no relevant data are available for salt mixtures. The information from sub-task 5.1.1.3 gives a variation in the existing EP bath mixture. One needs to discuss by whom, and under which activity, the test of this mixture will be done. Presently the single cell infrastructure is not available. On the other hand industrial companies should have the capability to change the mixture in use for the single cell test program at DESY.

### **JRA1.5.3 Automated EP**

The automated EP System has been tested on copper and given satisfaction. The program has been written in LabView and has been installed onto PLC Field point. This has the big advantage of not losing the control of the working point during the locking procedure around the minimum of the EP bath differential conductivity. That was indeed the main problem we faced during our preliminary attempts of dynamic control of the EP differential conductivity by a simple PC, due to the fact that standard PCs often interrupt the process just while refreshing so that the dynamic control is often lost. The operation on niobium is more critical, not only from the data processing point of view, due to the presence of plateau oscillations, but also from the security aspect. Therefore, the application of the automated EP to the niobium is in progress. The EP design control architecture is finished and the software has already been tested successfully. While testing, however, we decided to improve the algorithm by trying to insert the possibility of self-recognition of the minima by the program. Moreover, we decided to add a few more buttons to work manually, semi-automatically and totally automatically. This last possibility is very complex; therefore, reaching this milestone requires further investigation.

As far as the new electrolytes are concerned, we have found alternative recipes based on oxalic and boric acids instead of sulphuric acid. Hydrofluoric acid is still present; we are evaluating the possibility to work without it, which means that the milestones are not complete and that they will be finished by December.

### **JRA1.5.4 Dry-ice cleaning**

During the commissioning of the system, the efficiency of the heater unit was identified, surprisingly, to be insufficient. The heater unit will prevent strong cooling of the cavity during the dry-ice treatment. After some preliminary tests on niobium material, a bid for a new, high efficiency, infra red heater unit is on hand and the order is under preparation. In addition the complex control system is further delayed. The main reason is man-power problems caused by unexpected repair and maintenance work for the HERA accelerator at DESY. The gas alarm system for the personal interlock system is ordered.

## JRA1.5.5 Overall Progress of Work Package 5

The following table highlights the progress of work planned in the year 2005 for the Work Package WP5 by listing the lowest level subtasks of the SRF detailed implementation plan.

N°	Task Name	MS, Deliverable	Contractor	% aschlo	2005				2006	
					1.Q05	2.Q05	3.Q05	4.Q05	1.Q06	2.Q06
<b>5</b>	<b>WP5 SURFACE PREPARATION</b>			<b>32%</b>						
<b>5.1</b>	<b>EP on single cells</b>		<b>CEA</b>	<b>40%</b>						
<b>5.1.1</b>	<b>EP on samples</b>		<b>CEA</b>	<b>58%</b>						
5.1.1.1	Establishing method of surface characterization		CEA	100%						
5.1.1.2	Surface characterization fixed	Design Report	CEA	100%						
5.1.1.3	Series of EP with samples for surface investigations		CEA	50%						
5.1.1.4	Best EP parameters	Final Report	CEA	0%						
<b>5.1.2</b>	<b>Single cell cavities</b>		<b>CEA</b>	<b>100%</b>						
5.1.2.1	Order Nb and fabricate 3 cavities		CEA	100%						
5.1.2.2	3 cavities fabricated	Cavities read	CEA	100%						
<b>5.1.3</b>	<b>Build EP chemistry for single cells</b>		<b>CEA</b>	<b>43%</b>						
5.1.3.1	Design of EP set-up		CEA	90%						
5.1.3.2	Fabrication of EP set-up		CEA	95%						
5.1.3.3	Commissioning of EP set-up		CEA	0%						
5.1.3.4	First operation of EP set-up	Commissionin	CEA	0%						
<b>5.1.4</b>	<b>Operation of single cell EP</b>		<b>CEA</b>	<b>0%</b>						
5.1.4.1	Continuous single cell operation		CEA	0%						
5.1.4.2	Define working parameters for single cells	Design Report	CEA	0%						
<b>5.1.5</b>	<b>Continuous operation, search for best parameters</b>		<b>CEA</b>	<b>0%</b>						
5.1.5.1	Parametrising EP procedure		CEA	0%						
5.1.5.2	EP parameters fixed	Final Report	CEA	0%						
<b>5.2</b>	<b>EP on multi-cells</b>		<b>DESY</b>	<b>35%</b>						
<b>5.2.1</b>	<b>Transfer of parameters from 1 cell to multi cell equipment</b>		<b>DESY</b>	<b>66%</b>						
<b>5.2.1.1</b>	<b>Finish EP setup nine-cells at DESY</b>		<b>DESY</b>	<b>92%</b>						
5.2.1.1.1	Improved gas cleaning system		DESY	100%						
5.2.1.1.2	Design for hot water rinsing		DESY	90%						
5.2.1.1.3	Proof-of-Principle experiment hot water rinsi	Status Report	DESY	0%						
<b>5.2.1.2</b>	<b>Optimize electrode shape</b>		<b>DESY</b>	<b>45%</b>						
5.2.1.2.1	Develop computer model/ Evaluate software		DESY	100%						
5.2.1.2.2	Design improved electrode		DESY	0%						
5.2.1.2.3	Electrode design fixed	Design report	DESY	0%						
<b>5.2.1.3</b>	<b>Fix process parameters/ Quality control</b>		<b>DESY</b>	<b>49%</b>						
5.2.1.3.1	Setup chemical lab		DESY	100%						
5.2.1.3.2	Bath aging		DESY	70%						
5.2.1.3.3	Bath mixture		DESY	50%						
5.2.1.3.4	Alternative (salt) mixtures		DESY	0%						
5.2.1.3.5	Process parameters fixed	Final Report	DESY	1%						
<b>5.2.2</b>	<b>Laser roughness</b>		<b>DESY</b>	<b>6%</b>						
5.2.2.1	Evaluate existing systems		DESY	20%						
5.2.2.2	Specify laser system		DESY	0%						
5.2.2.3	Built laser system		DESY	0%						
5.2.2.4	Roughness measurement finished	Equipment read	DESY	0%						
<b>5.2.3</b>	<b>Oxipolishing as final chemical cleaning</b>		<b>DESY</b>	<b>38%</b>						
5.2.3.1	Laboratory studies		DESY	30%						
5.2.3.2	Design of OP system		DESY	70%						
5.2.3.3	Setup one-cell system		DESY	77%						
5.2.3.4	Proof-of-Principle experiment Oxipolishing	Status Report	DESY	0%						
5.2.3.5	Design OP for nine-cells		DESY	30%						
5.2.3.6	Build OP for 9-cells		DESY	0%						
5.2.3.7	OP for 9-cells ready	Commissionin	DESY	0%						
5.2.3.8	Study op with 9-cell cavities		DESY	0%						
5.2.3.9	Evaluate experiments	Status Rtepor	DESY	0%						
<b>5.2.4</b>	<b>Transfer Electropolishing technology to industry</b>		<b>DESY</b>	<b>4%</b>						
5.2.4.1	Qualify industry with one-cells		DESY	10%						
5.2.4.2	Industrial design study on setup for multi-cells		DESY	10%						
5.2.4.3	Report on industrial design	Report	DESY	0%						
5.2.4.4	Fabricate EP multi-cell industrial prototype		DESY	0%						
5.2.4.5	Commission EP multi-cell industrial prototype		DESY	0%						
5.2.4.6	EP multi-cell industrial prototype ready	Commissionin	DESY	0%						
5.2.4.7	Operate EP multi-cell industrial prototype		DESY	0%						
5.2.4.8	Final report on industrial EP	Final Report	DESY	0%						

A. ACTIVITY REPORT

N°	Task Name	MS, Deliverable	Contractor	% as scheduled	2005				2006	
					1.Q05	2.Q05	3.Q05	4.Q05	1.Q06	2.Q06
<b>5.3</b>	<b>Automated EP (AEP)</b>		<b>INFN-LNL</b>	<b>38%</b>						
<b>5.3.1</b>	<b>Prototype EP installation</b>		<b>INFN-LNL</b>	<b>99%</b>						
5.3.1.1	Design installation		INFN-LNL	100%						
5.3.1.2	Fabricate/ order components		INFN-LNL	100%						
5.3.1.3	Assemble EP installation		INFN-LNL	100%						
5.3.1.4	<b>First operation of automated EP</b>	<b>Commissionin</b>	INFN-LNL	0%	08.02.					
<b>5.3.2</b>	<b>EP computer control</b>		<b>INFN-LNL</b>	<b>95%</b>						
5.3.2.1	Design control architecture		INFN-LNL	100%						
5.3.2.2	Developed software		INFN-LNL	100%						
5.3.2.3	Test of software		INFN-LNL	80%						
5.3.2.4	<b>Software ready</b>	<b>Status Repor</b>	INFN-LNL	80%	21.02.					
<b>5.3.3</b>	<b>Operation of AEP prototype</b>		<b>INFN-LNL</b>	<b>30%</b>						
5.3.3.1	Correlate surface finish/ conductance		INFN-LNL	30%						
5.3.3.2	Determine optimum conductance		INFN-LNL	80%						
5.3.3.3	Optimize automated operation		INFN-LNL	0%						
5.3.3.4	Design report on AEP		INFN-LNL	0%						
5.3.3.5	<b>Automated EP is defined</b>	<b>Final Report</b>	INFN-LNL	0%	13.02.					
<b>5.3.4</b>	<b>Alternative electrolytes</b>		<b>INFN-LNL</b>	<b>13%</b>						
5.3.4.1	Review of EP chemistry		INFN-LNL	50%						
5.3.4.2	<b>Proposal for alternative electrolytes</b>	<b>Report</b>	INFN-LNL	50%	24.05.					
5.3.4.3	Experiments with alternative electrolytes		INFN-LNL	0%						
5.3.4.4	<b>Conclude experimental results</b>	<b>Status Repor</b>	INFN-LNL	0%						
<b>5.3.5</b>	<b>Define best AEP</b>		<b>INFN-LNL</b>	<b>0%</b>						
5.3.5.1	Compare standard/new electrolyte method		INFN-LNL	0%						
5.3.5.2	Modify AEP installation for best electrolyte		INFN-LNL	0%						
5.3.5.3	Operate modified AEP		INFN-LNL	0%						
5.3.5.4	Design report on best AEP		INFN-LNL	0%						
5.3.5.5	<b>Conclude on best electrolyte</b>	<b>Final Report</b>	INFN-LNL	0%						
<b>5.4</b>	<b>Dry ice cleaning</b>		<b>DESY</b>	<b>12%</b>						
<b>5.4.1</b>	<b>Installation of full system for 1-3 cell cavities</b>		<b>DESY</b>	<b>83%</b>						
5.4.1.1	Installation of CO2 piping		DESY	100%						
5.4.1.2	Installation of motion system		DESY	100%						
5.4.1.3	Installation of control system		DESY	80%						
5.4.1.4	Commissioning		DESY	40%						
5.4.1.5	<b>Installation finished</b>	<b>Commissionin</b>	DESY	40%	11.04.					
<b>5.4.2</b>	<b>Optimization of cleaning parameters</b>		<b>DESY</b>	<b>0%</b>						
5.4.2.1	Sample cleaning		DESY	0%						
5.4.2.2	1-cell cavity cleaning		DESY	0%						
5.4.2.3	Fix best cleaning parameters		DESY	0%						
5.4.2.4	<b>Cleaning parameters fixed</b>	<b>Final Report</b>	DESY	0%	06.10.					
<b>5.4.3</b>	<b>VT 9-cell cleaning apparatus</b>		<b>DESY</b>	<b>0%</b>						
5.4.3.1	Design 9-cell apparatus VT		DESY	0%						
5.4.3.2	Fabricated 9-cell apparatus		DESY	0%						
5.4.3.3	Installation of 9-cell apparatus		DESY	0%						
5.4.3.4	Commissioning of 9-cell apparatus		DESY	0%						
5.4.3.5	<b>VT Cleaning installation finished</b>	<b>Commissionin</b>	DESY	0%	07.03.					
<b>5.4.4</b>	<b>VT Cleaning of 9-cell cavities</b>		<b>DESY</b>	<b>0%</b>						
5.4.4.1	Continuous cleaning		DESY	0%						
5.4.4.2	<b>Evaluation of experimental results</b>	<b>Final repor</b>	DESY	0%						
<b>5.4.5</b>	<b>Design &amp; construction of H 9-cell cleaning apparatus</b>		<b>DESY</b>	<b>0%</b>						
5.4.5.1	Design 9-cell apparatus VT		DESY	0%						
5.4.5.2	Fabricated 9-cell apparatus		DESY	0%						
5.4.5.3	Installation of 9-cell apparatus		DESY	0%						
5.4.5.4	Commissioning of 9-cell apparatus		DESY	0%						
5.4.5.5	<b>Start H 9-cell cleaning</b>	<b>Commissionin</b>	DESY	0%						
<b>5.4.6</b>	<b>Cleaning of horizontal nine-cell cavity</b>		<b>DESY</b>	<b>0%</b>						
5.4.6.1	Continuous cleaning		DESY	0%						
5.4.6.2	<b>Evaluation of experimental results</b>	<b>Final repor</b>	DESY	0%						

## JRA1.6 Work Package 6: Material Analysis

### JRA1.6.1 Development of SQUID based equipment for detection of defects in Nb

The construction of the system for non-destructive inspection of niobium sheets, based on a SQUID sensor, is finished.

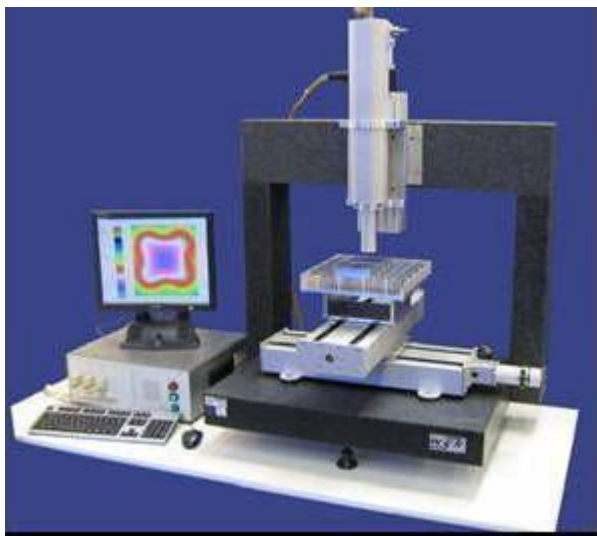


Figure JRA1.6.1: View of a SQUID scanner for Nb sheets

Fig.JRA1.6.1 shows the main components of the SQUID scanner. The scanner is based on a xyz table with ca. 300mm x 300mm travel area. The SQUID sensor is electronically controlled by a flux modulation and control loop, in order to keep the magnetic flux through the SQUID constant. The compensation current is controlled by the flux measurement. Different filters are implemented into the lock-in amplifier to improve the Signal/Noise ratio. The system works in a non-shielded environment.

The first testing of functionality was done at the end of June 2005. A specially prepared test sample was used in measurements. Eleven tantalum spheres with diameters of about 0.1 mm were embedded into a 30 x 30 cm<sup>2</sup> niobium sheet by electron-beam melting of the surface. First test results can be seen in Fig.JRA1.6.2.

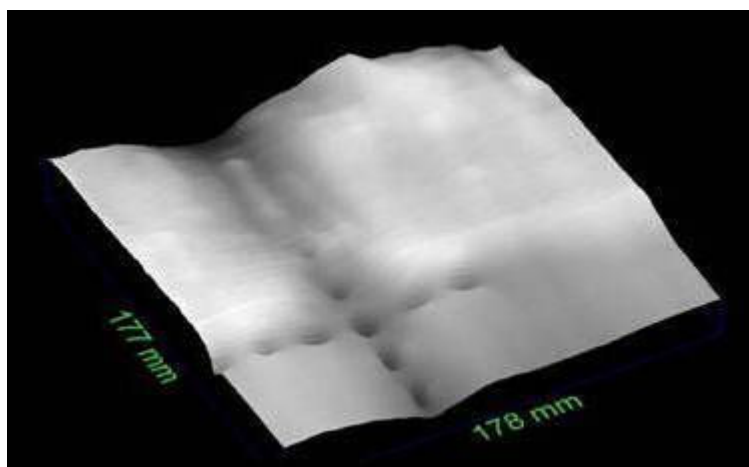


Figure JRA1.6.2: Three-dimensional distribution of the eddy-current field above the niobium test sample

The eddy-current frequency was 6 kHz. Nine of the eleven embedded Ta inclusions are clearly detected. The system is in position to detect defects in niobium. Further optimization of the system set up is in progress.

### JRA1.6.2 Flux gate magnetometry

The flux gate scanning apparatus has been designed and built, so that it can perform:

- i) A tomography of the electrolytic cell, in order to configure the effect of cathode geometry on electropolishing,
- ii) the distinction of Niobium with different RRR by relative measurements of conductivity by detecting the eddy current decay.

Referring to tomography of the electrolytic cells, we have fabricated a few elementary rectangular cells for the calibration procedure and several shaped electrolytic cells having the possibility to test different cathode shapes.

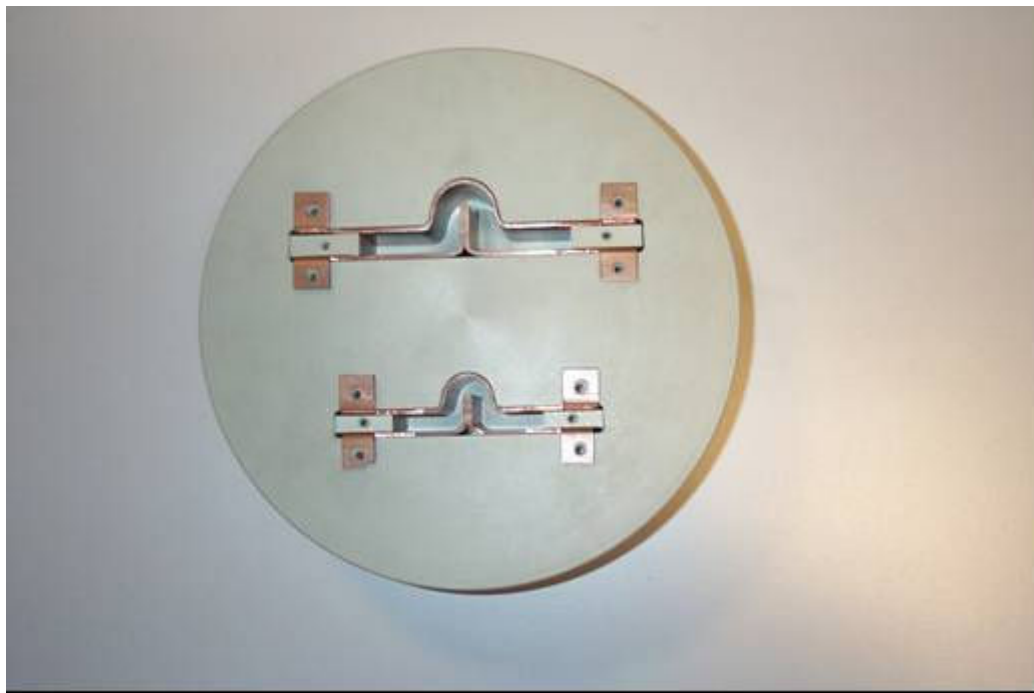


Figure JRA1.6.3: Cavity shaped electrolytic cells with a cathode totally entering into the cell.

Due to the large dimensions (around 5-6 mm diameter) of the flux gate, the quality of the tomography done up to now is not excellent. Thus we have bought fluxgates of reduced dimensions, which are at the moment under test. Meanwhile, we are ready to test the inversion program that extracts the current distribution from the magnetic field by inverting the three-dimensional Biot –Savart law.

Referring to the problem of detecting the defects on Niobium slabs, we have also designed the experiment to monitor two different kind of defected samples:

- Physical defects like surface scratches and foreign particle embedded onto Niobium
- Samples with degraded RRR to distinguish from samples with RRR 300.



Figure JRA1.6.4: The scanning flux gate apparatus.

### JRA1.6.3 DC field emission scanning

The automated field emission scanning measurements (FESM), programmed in LabVIEW, were successfully started at the beginning of 2005 at the University of Wuppertal. Two Nb samples electropolished (EP) at Saclay (SEP1&2) were systematically scanned at surface electric fields of 40-120 MV/m before and after high pressure rinsing (HPR) at DESY. Both EP samples showed an onset of FE at surface fields around 40 MV/m and emitter number densities up to 30/cm<sup>2</sup> at 120 MV/m. After HPR, the FE of SEP2 was clearly improved, i.e. the onset field increased to 60 MV/m and the emitter number density reduced to 14/cm<sup>2</sup> at 120 MV/m (Fig.JRA1.6.5).



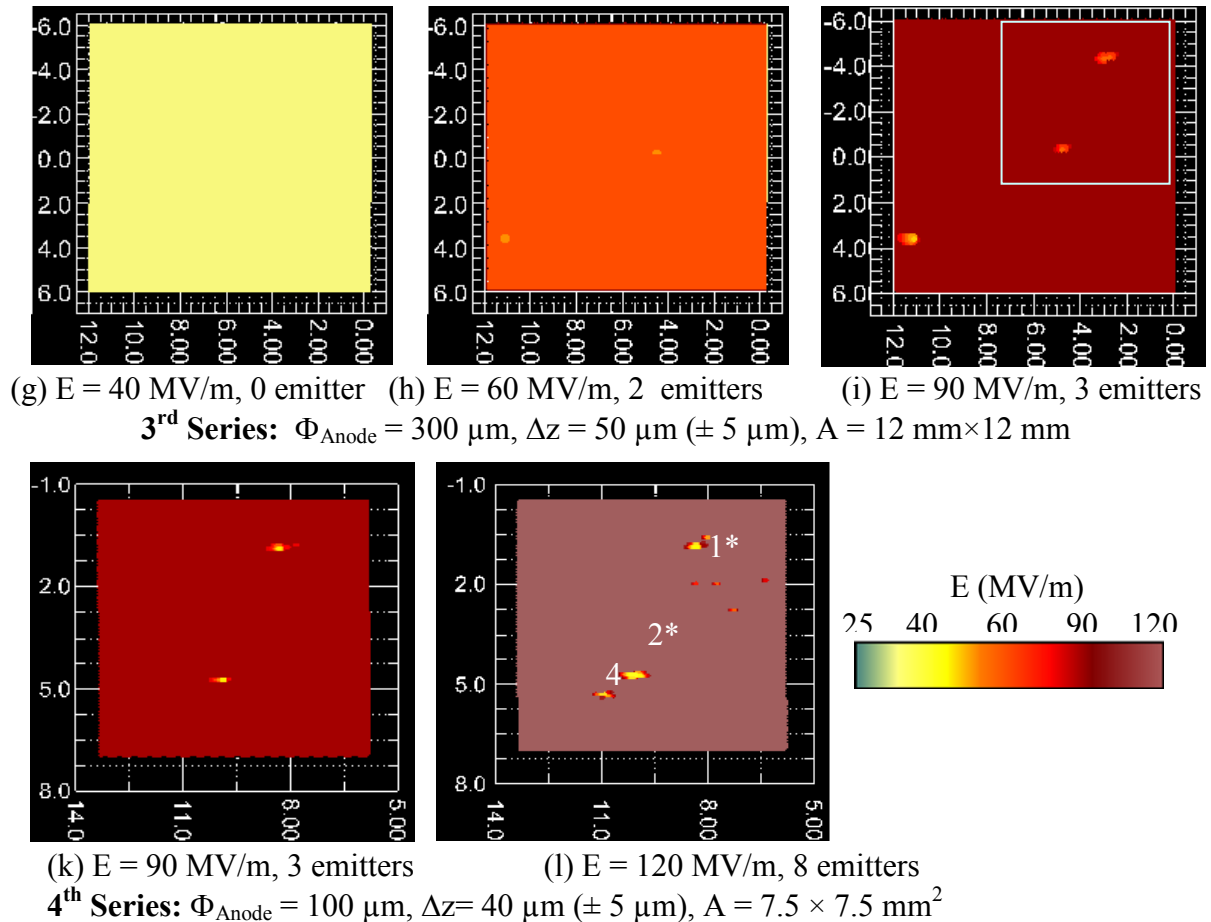
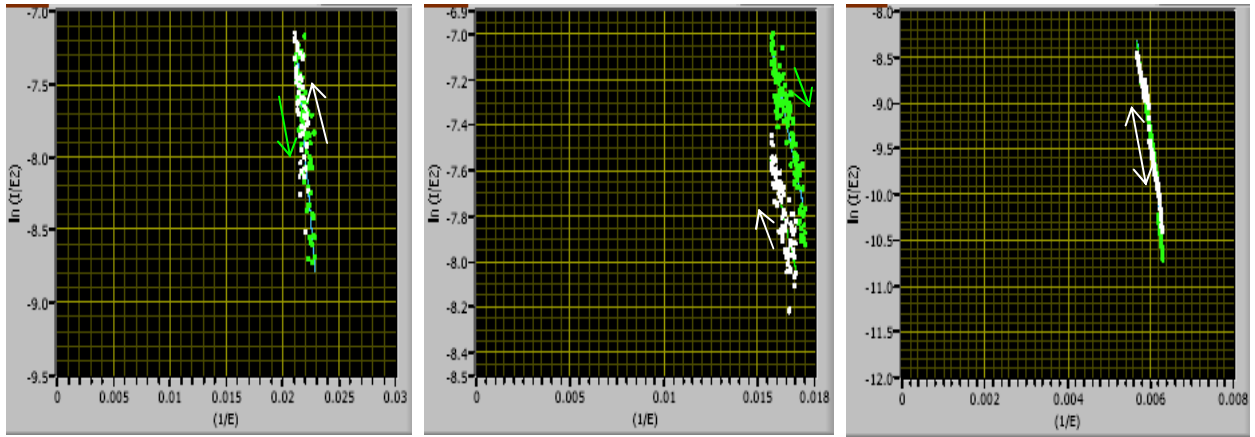


Figure JRA1.6.5: Regulated voltage maps of EP-Nb sample SEP2 after HPR at various field levels showing the onset field of emitters (color bar). The maps k and l correspond to the marked area in map i.

In order to learn more about the nature of these emitters, local measurements with the FESM (Fig.JRA1.6.6) and surface analysis with SEM and EDX (Fig.JRA1.6.3) were performed on some strong emitters. The I-V curves showed nearly stable Fowler-Nordheim (FN) behavior with local field enhancement factors between 17 and 231 which are typical for particulates and surface irregularities. High resolution SEM and EDX measurements revealed three types of emitters: a thin conductive object with sub-micron protrusions, a scratch-like surface defect and a crystalline particle with S, Cl and K content.



#1* $E_{on}(1\text{ nA}) = 68.7\text{ MV/m}$	#3* $E_{on}(1\text{ nA}) = 48.5\text{ MV/m}$	#4 $E_{on}(1\text{ nA}) = 76.9\text{ MV/m}$
$\beta_{\uparrow} = 75.1, S_1 = 1.6 \times 10^{-15}\text{ m}^2$	$\beta_{\uparrow} = 166.6, S_1 = 1.6 \times 10^{-20}\text{ m}^2$	$\beta_{\uparrow} = 19.3, S_1 = 1 \times 10^{-13}\text{ m}^2$
$\beta_{\downarrow} = 64.6, S_2 = 2.4 \times 10^{-13}\text{ m}^2$	$\beta_{\downarrow} = 147.6, S_2 = 7.2 \times 10^{-20}\text{ m}^2$	$\beta_{\downarrow} = 17.9, S_2 = 5 \times 10^{-13}\text{ m}^2$

Figure JRA1.6.6: I-V curves and FN parameters of single emitters # 1, 3 and 4 as marked in Fig.JRA1.1(l).

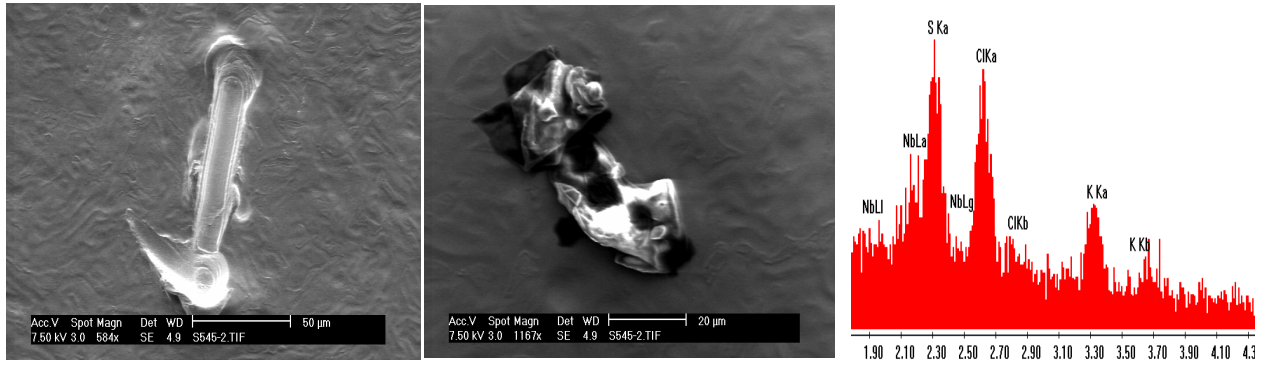


Figure JRA1.6.3: SEM images of emitter #3\* (left) and #4\* (middle). The EDX spectrum of emitter #4\* shows S, Cl, K contents (right).

These results have been summarized in the mile-stone report (6.3.1.7), presented as a poster contribution at the International Workshop on RF Superconductivity at Cornell University in July 2005 and submitted to the workshop proceedings.

As the next step, the dry ice cleaning (DIC) of these two Nb samples was performed at DESY. The most recent scans on SEP2 have shown no emitters up to fields of about 90 MV/m, i.e. much reduced FE after DIC as compared to HPR, but they have to be confirmed with sample SEP1.

A series of new high-purity Nb (RRR=300) samples of 28 mm diameter has been fabricated at DESY which provides improved mechanical strength for assembly inside 9-cell cavities for the regular quality control of the standard EP and HPR processes at DESY. FESM investigations of these samples will start in January 2006.

### JRA1.6.4 Overall Progress of Work Package 6

The following table highlights the progress of work planned in the year 2005 for the Work Package WP6 by listing the lowest level subtasks of the SRF detailed implementation plan.

N°	Task Name	MS, Deliverable	Contractor	% aschlo	2005				2006	
					1.Q05	2.Q05	3.Q05	4.Q05	1.Q06	2.Q06
<b>6</b>	<b>WP6 MATERIAL ANALYSIS</b>			<b>31%</b>						
<b>6.1</b>	<b>SQUID scanning</b>		<b>DESY</b>	<b>64%</b>						
<b>6.1.1</b>	<b>Produce calibration defects</b>		<b>DESY</b>	<b>100%</b>						
6.1.1.1	Production of surface defects		DESY	100%						
6.1.1.2	Production of bulk defects		DESY	100%						
6.1.1.3	Calibration defects finished	Status Repor	DESY	100%						
<b>6.1.2</b>	<b>Design components of Squid scanner</b>		<b>DESY</b>	<b>100%</b>						
6.1.2.1	Design of the scanning table and support		DESY	100%						
6.1.2.2	Design of the SQUID cooling system		DESY	100%						
6.1.2.3	Design Scanner finished	Design repor	DESY	100%						
<b>6.1.3</b>	<b>Construction of scanning apparatus</b>		<b>DESY</b>	<b>100%</b>						
6.1.3.1	Fabrication of the SQUID		DESY	100%						
6.1.3.2	Fabrication and purchase of components for SQUID apparatus		DESY	100%						
6.1.3.3	Softw are for the SQUID scanner		DESY	100%						
6.1.3.4	Commissioning and calibration of scanning apparatus		DESY	100%						
6.1.3.5	Scanning apparatus operational	Commissionin	DESY	100%						
<b>6.1.4</b>	<b>Scanning of sheets with artificial defects</b>		<b>DESY</b>	<b>8%</b>						
6.1.4.1	Scanning of sheets with artificial surface defects		DESY	10%						
6.1.4.2	Scanning of sheets with artificial bulk defects		DESY	10%						
6.1.4.3	Development of algorithm for material defects classification		DESY	0%						
6.1.4.4	Classification of defects finished	Status Repor	DESY	0%						
<b>6.1.5</b>	<b>Scanning of production sheets</b>		<b>DESY</b>	<b>0%</b>						
6.1.5.1	Scanning of sheets of different producers		DESY	0%						
6.1.5.2	Identification of defects by (EDX, SURFA etc.)		DESY	0%						
6.1.5.3	Conclusive comparison with eddy current data		DESY	0%						
6.1.5.4	Final report on SQUID scanning	Final Report	DESY	0%						
<b>6.2</b>	<b>Flux gate magnetometry</b>		<b>INFN-LNL</b>	<b>40%</b>						
<b>6.2.1</b>	<b>Produce calibration defects</b>		<b>INFN-LNL</b>	<b>41%</b>						
6.2.1.1	Production of surface defects		INFN-LNL	100%						
6.2.1.2	Production of bulk defects		INFN-LNL	0%						
6.2.1.3	Calibration defects finished	Status Repor	INFN-LNL	63%						
<b>6.2.2</b>	<b>Design components of flux gate head</b>		<b>INFN-LNL</b>	<b>100%</b>						
6.2.2.1	Design electronics		INFN-LNL	100%						
6.2.2.2	Design of flux gate head		INFN-LNL	100%						
6.2.2.3	Design of operations softw are		INFN-LNL	100%						
6.2.2.4	Design flux gate head finished	Design repor	INFN-LNL	100%						
<b>6.2.3</b>	<b>Fabrication of flux gate detector</b>		<b>INFN-LNL</b>	<b>63%</b>						
6.2.3.1	Fabrication of flux gate head		INFN-LNL	90%						
6.2.3.2	Fabrication of mechanics		INFN-LNL	60%						
6.2.3.3	Implementation of softw are		INFN-LNL	60%						
6.2.3.4	Commissioning of flux gate detector		INFN-LNL	30%						
6.2.3.5	Calibration of flux gate detector		INFN-LNL	60%						
6.2.3.6	Flux gate detector operational	Design report, sta operator	INFN-LNL	58%						
<b>6.2.4</b>	<b>Commissioning of flux gate detector</b>		<b>INFN-LNL</b>	<b>0%</b>						
6.2.4.1	Operational tests tests		INFN-LNL	0%						
6.2.4.2	Evaluation of test results		INFN-LNL	0%						
6.2.4.3	Flux gate scanner commissioned	Status Repor	INFN-LNL	0%						
<b>6.2.5</b>	<b>Operation of flux gate detector</b>		<b>INFN-LNL</b>	<b>0%</b>						
6.2.5.1	Regular operation		INFN-LNL	0%						
6.2.5.2	Report of operation		INFN-LNL	0%						
6.2.5.3	Conclusion of flux gate scanning operation	Status Repor	INFN-LNL	0%						
<b>6.2.6</b>	<b>Comparison with SQUID scanner</b>		<b>INFN-LNL</b>	<b>0%</b>						
6.2.6.1	Compare measurements		INFN-LNL	0%						
6.2.6.2	Conclude SQUID scanner vs. flux gate detector	Final Report	INFN-LNL	0%						
<b>6.3</b>	<b>DC field emission studies of Nb samples</b>		<b>DESY</b>	<b>6%</b>						
<b>6.3.1</b>	<b>Quality control scans</b>		<b>DESY</b>	<b>14%</b>						
6.3.1.1	Modification of Scanning apparatus		DESY	100%						
6.3.1.2	Calibration of Scanning apparatus		DESY	100%						
6.3.1.3	Start scanning activity	Start Operator	DESY	100%						
6.3.1.4	BCP and HPR samples		DESY	30%						
6.3.1.5	EP and HPR samples		DESY	10%						
6.3.1.6	BCP/EP and DC samples		DESY	0%						
6.3.1.7	First report on BCP/EP and DIC surface	Interim Repor	DESY	0%						
6.3.1.8	Continue QA scanning		DESY	0%						
6.3.1.9	Evaluation of scanning results	Final Report	DESY	0%						
<b>6.3.2</b>	<b>Detailed measurements on strong emitters</b>		<b>DESY</b>	<b>0%</b>						
6.3.2.1	Calibrate apparatus for high current		DESY	0%						
6.3.2.2	Start strong emitter evaluation	Start Measuremen	DESY	0%						
6.3.2.3	IV curves and current limits		DESY	0%						
6.3.2.4	SEM and AES		DESY	0%						
6.3.2.5	Influence of heat treatment and ion impact		DESY	0%						
6.3.2.6	Evaluate strong emitter investigations	Final Report	DESY	0%						

## JRA1.7 Work Package 7: Couplers

### JRA1.7.1 New Prototype Couplers

We have designed two new proto-types named TTF-V and TW60 respectively. The RF design of these couplers was completed in 2004. The TTF-V coupler is inspired from the TTF-III couplers used on the TTF VUV-FEL, however, the “cold” part of the coupler has its outside diameter increased to 62 mm with the aim of allowing higher power operation and pushing multipactor limits to higher levels. The coupler then has 50  $\Omega$  impedance for both warm and cold assemblies. Such a coupler may be of interest for a ‘superstructure’ version of the TESLA cavity (i.e. a 2 x 9 cell cavity). The TW60 coupler (TW for Travelling Wave) has a radically different window geometry. The warm and cold windows are thin ceramic disks brazed into the co-axial coupler line. The impedance mismatch of the warm ceramic is compensated by a reduced height wave-guide section in front of the wave-guide to co-ax transition. The cold window impedance is matched to the travelling wave via inductive elements on the outer co-axial line. This implies some standing wave field component, however, calculations show that the RF fields are not excessive. The return loss of the TTF-V coupler, as calculated with the code HFSS is shown in Fig. JRA1.7.1. Schematic drawings of the couplers are shown in Figures JRA1.7.2.a and JRA1.7.2.b.

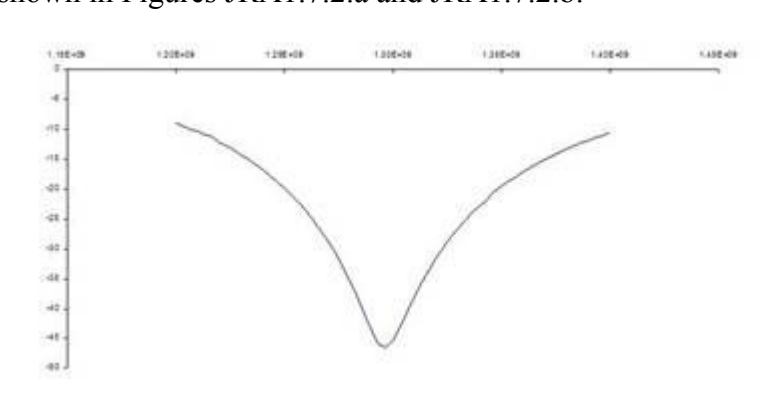


Figure JRA1.7.1: Calculated frequency dependence of the return loss of the TTF-V coupler.

Engineering drawings of the couplers, prepared during the last reporting period, were used in calls for tenders for both proto-types to be manufactured as “equipment built to specification”. Detailed technical specification documents were prepared for each of these calls. Four copies of each coupler have been ordered. In the case of the TW60 coupler, a wave-guide test box will also be built. The time required for the company to deliver the proto-types is approximately one year. Consequently, the TTF-V couplers are expected in May of 2006 and the TW60 couplers in August of 2006. Following the recommendations of the International Scientific Advisory Committee from the 2004 annual CARE meeting, we have started to perform thermal simulations of the proto-types. For this purpose we have purchased a fixed-term licence for the ANSYS code. These calculations are in progress (Fig. JRA1.7.3).

A significant effort from the drawing office has been made to provide a complete set of drawings of a modified TTF-III coupler. These drawings incorporate new, relaxed, fabrication tolerances which hopefully will result in reduced manufacturing costs. The drawings also include an automated movement of the central antenna of the coupler via a stepping motor. This improvement is necessary for a coupler to be used on any long super-conducting linac such as the European XFEL or the International Linear Collider.

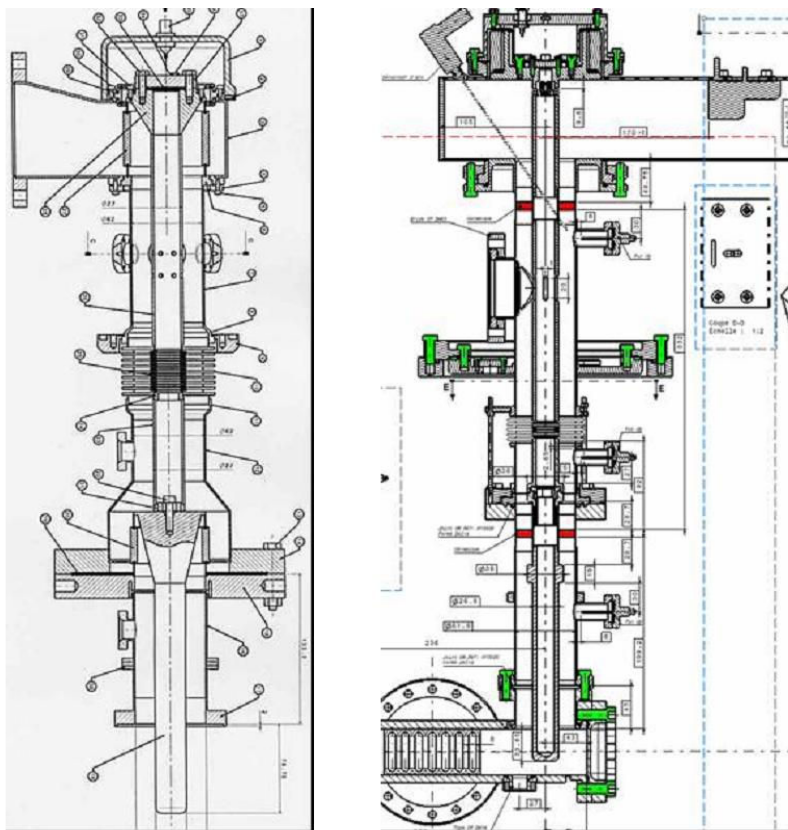


Figure JRA1.7.2: Schematics of the TTF-V Coupler (left) and of the TW60 Coupler (right).

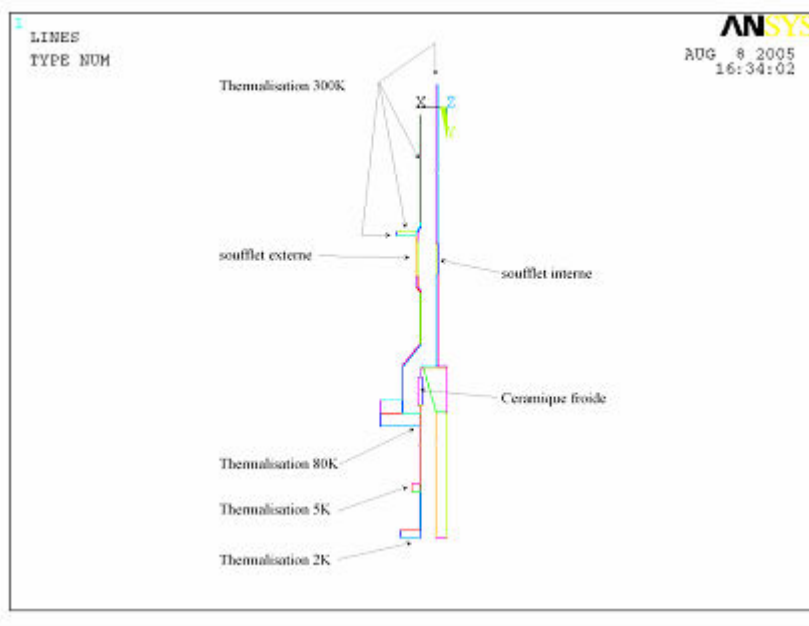


Figure JRA1.7.3: ANSYS model for the thermal calculation of TTF-V.

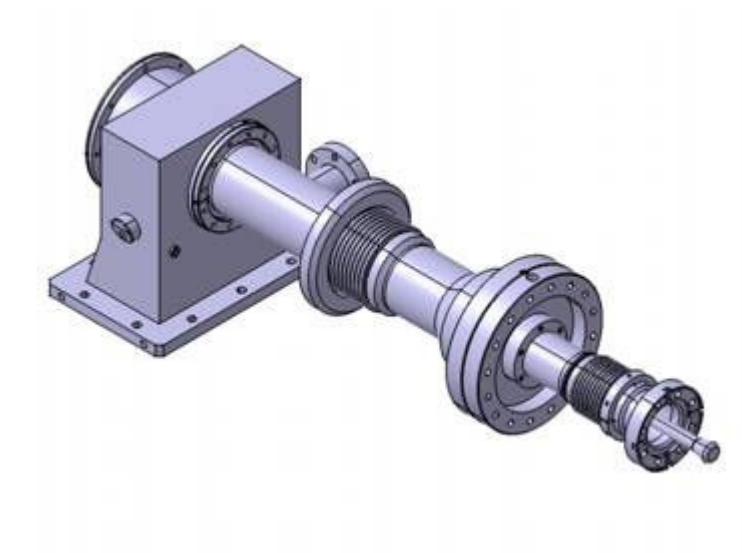


Figure JRA1.7.4: Computer Aided Design image of the modified TTF-III coupler.

Two couplers of the TTF-III type, but fabricated using a different method from that used habitually, have been delivered. The windows of these couplers have not yet received their anti-multipactor coating as it was feared that a brazing operation during their fabrication may have removed or damaged the coating. They will be coated later at DESY or by industry and will be tested under high power in 2006.

#### **JRA1.7.2 Fabrication of a titanium-nitride coating bench for the coupler ceramic windows**

For Task 7.2 we have already begun to perform some bibliographic research on coating benches. A preliminary technical specification of the bench we wish to build is given in an internal technical note. The first contacts with three companies specialised in the fabrication of coating benches have taken place. Preliminary enquiries indicate that we can purchase an industrially built sputtering system well adapted to the ceramic geometry. Construction would require six months. To date, the coupler ceramics have been coated using an evaporation technique and we are concerned that the quality of the coating may be poorer with a sputtering system. We intend to perform comparative tests on ceramic samples before making a firm decision on the choice of bench. This may result in some delay in the construction of the bench with respect to the initial schedule.

#### **JRA1.7.3 Conditioning studies of proto-type couplers**

Task 7.3, conditioning studies, has represented a considerable part of our effort in 2005. In principle, we wish to perform conditioning studies on the prototypes TTF-V and TW60. While awaiting delivery of these couplers we have started conditioning tests with TTF-III couplers purchased in the context of a DESY - CNRS-Orsay (LAL) collaboration. These tests provide us with valuable experience of the operation of our conditioning bench along with its associated diagnostics and control system. Before conditioning, the couplers have to undergo a rigid procedure of ultra-sonic cleaning, with ultra-pure water (electrical resistivity = 18 M $\Omega$ .cm), rinsing (again with ultra-pure water) drying in a class 10 clean room (Fig. JRA1.7.5), baking in vacuum, assembly in the class 10 clean room and finally mounting to the RF bench under a mobile laminar flow providing class 100 conditions. The couplers, tested in pairs (Fig. JRA1.7.6), undergo an in-situ bake-out at 150 °C for 24 hours before the RF is applied. The rigorous application of this procedure is indispensable if one wishes to obtain good coupler performance. A *quality assurance* document has been established to guide the technical staff in the application of these procedures.





Figure JRA1.7.5: Coupler assembly in class 10 clean room.



Figure JRA1.7.6: TTF-III couplers being conditioned.

A histogram showing conditioning times for different pairs of couplers is shown in Figure JRA1.7.7. The spread in conditioning times, for couplers having received an in-situ bake-out, (40 ~ 90 hours) is lower, in general, than that observed at DESY. Nevertheless, we still have relatively few pairs conditioned. The reason for the spread will be the subject of further studies (differences in coupler manufacturing, differences in preparation), in the hope that eventually all couplers can be conditioned faster or at least as fast as the shortest conditioning time observed to date. Note the coupler pair which exhibits the shortest conditioning time (~ 22 hours) was conditioned using higher vacuum threshold levels within the automated conditioning routine (threshold levels which determine if the power level can be incremented. Electronic racks for diagnostic devices (electron pick-ups, photo-multiplier, temperature sensor) have been built which will allow couplers to be safely tested at low temperature in CryHoLab.

The work of WP7 has been presented at the following scientific meetings during 2005: The International Workshop on RF Superconductivity (Cornell); The 2<sup>nd</sup> International Linear Collider Workshop (Snowmass); *Les Journées Accélérateurs de la Société Française de Physique* (Roscoff).

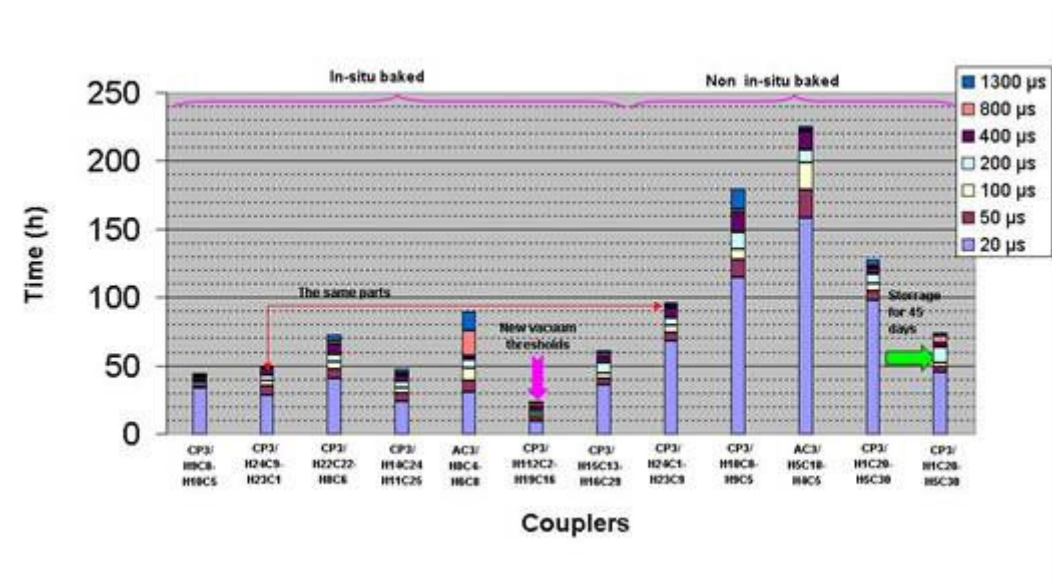


Figure JRA1.7.7: Histogram of conditioning times for different coupler pairs.

## JRA1.7.4 Overall Progress of Work Package 7

The following table highlights the progress of work planned in the year 2005 for the Work Package WP7 by listing the lowest level subtasks of the SRF detailed implementation plan.

N°	Task Name	MS, Deliverable	Contractor	% aschlo	2005				2006	
					1.Q05	2.Q05	3.Q05	4.Q05	1.Q06	2.Q06
<b>7</b>	<b>WP7 COUPLERS</b>			<b>13%</b>						
<b>7.1</b>	<b>New Prototype Coupler</b>		<b>CNRS-Orsay</b>	<b>50%</b>						
7.1.1	RF Simulations of Coupler		CNRS-Orsay	100%						
7.1.2	Report on Simulation		CNRS-Orsay	100%						
7.1.3	Detailed Engineering Draw ings		CNRS-Orsay	100%						
7.1.4	Engineering complete		CNRS-Orsay	100%						
7.1.5	Call for tenders		CNRS-Orsay	100%						
7.1.6	Prototype Fabrication in Industry		CNRS-Orsay	0%						
7.1.7	Low Power tests		CNRS-Orsay	0%						
7.1.8	<b>Ready for High Power Tests</b>	<b>Coupler Prototyp</b>	CNRS-Orsay	0%						
<b>7.2</b>	<b>Fabrication of TiN Coating System</b>		<b>CNRS-Orsay</b>	<b>0%</b>						
7.2.1	Mechanical design of vacuum chamber		CNRS-Orsay	0%						
7.2.2	Fabrication draw ings		CNRS-Orsay	0%						
7.2.3	Construction of vacuum chamber		CNRS-Orsay	0%						
7.2.4	Def ne vacuum needs		CNRS-Orsay	0%						
7.2.5	Appropriation of vacuum equipment		CNRS-Orsay	0%						
7.2.6	Design of electronic circuitry		CNRS-Orsay	0%						
7.2.7	Fabrication of electronics in industry		CNRS-Orsay	0%						
7.2.8	Installation and Test at Orsay		CNRS-Orsay	0%						
7.2.9	<b>First Window Coating</b>	<b>Commissionin</b>	CNRS-Orsay	0%						
<b>7.3</b>	<b>Conditioning Studies of Proto-type Couplers</b>		<b>CNRS-Orsay</b>	<b>0%</b>						
7.3.1	Conditioning of couplers		CNRS-Orsay	0%						
7.3.2	Evaluate conditioning results		CNRS-Orsay	0%						
7.3.3	<b>Final report on conditioning</b>	<b>Final Report</b>	CNRS-Orsay	0%						

## JRA1.8 Work Package 8: Tuners

### JRA1.8.1 UMI Tuner (INFN-Mi)

The new INFN coaxial blade tuner construction is nearly finished. All the parts have already been constructed by ZANON, where the assembly of two complete prototypes, including the modified helium tank, is well in progress.

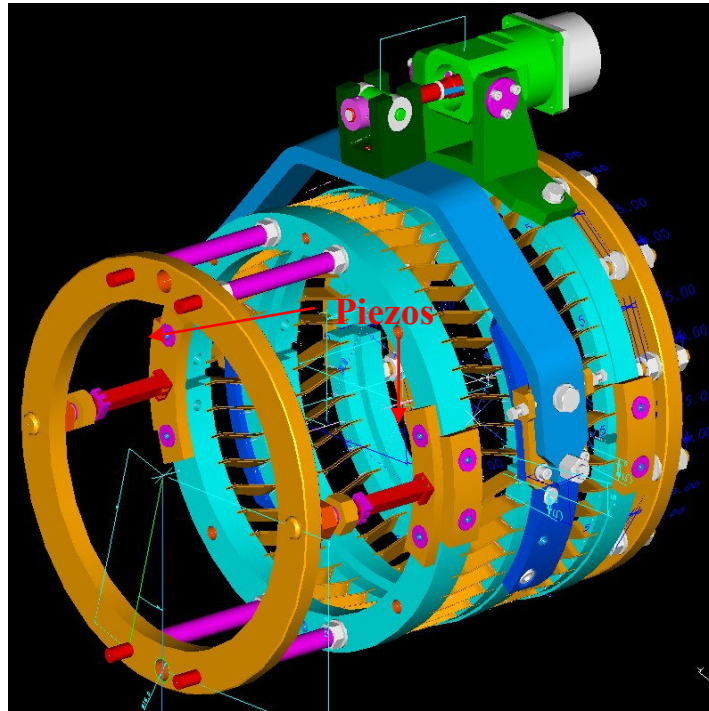


Figure JRA1.8.1: The INFN Blade Tuner provided with piezo actuators for fast tuning activity.

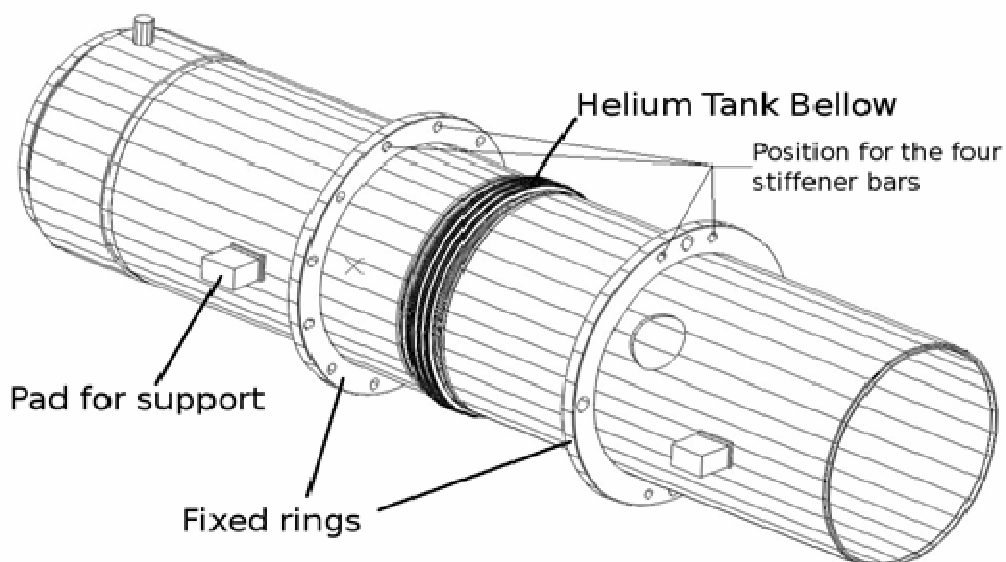


Figure JRA1.8.2. Helium tank showing the bellow, the fixed rings and the support pads.

The integration of piezostacks for Lorentz forces and microphonics compensation is completed for what concerns the tuner prototypes. Many piezo models from different manufacturers have been deeply characterized relating to their main extensive properties, such as blocking force, maximum stroke, length, maximum load. The final choice, the Noliac

SCMA/S1/A/10/10/40/200/60/4000, fits all the requirements. Moreover, the tuner is designed to be compatible with other active elements, be they other kind of piezostacks (ad-hoc devices have been designed so that piezostacks of different section and length up to 72 mm can be accommodated) or even magnetostrictive actuators. The cavity elasticity is used to provide the piezo preload. Two cold tests are foreseen at the DESY and BESSY facilities at the beginning of 2006. In figure JRA1.8.1 you can see the coaxial blade tuner assembly, showing the leverage arm, the Ti ring welded on the tank and the two piezostacks. There is the possibility to use both piezostack as actuators, or to use one as a sensor.

The tuner assembly is mainly composed of three parts: the movement leverage, the bending rings (three rings) and the piezo actuators (see Figure JRA1.8.2). Two Ti fixed rings are welded to the helium tank to support the coaxial blade tuner, which is fixed to one of them by means of twelve bolts, while the other ring can receive up to four piezo actuators. Because the tuner is fixed to the helium tank, a bellow is needed between the two fixed rings. The number of convolutions has been computed in order to avoid any non-elastic strain in the bellow for a maximum axial displacement of 1.8 mm.

Due to the change of the helium tank with the introduction of the bellow, a bending analysis has been performed in order to check the vertical displacements of the cavity subject to its weight and to the weight of the tuner (Figure JRA1.8.3). The maximum sagging computed (0.12 mm) is less than the admissible tolerance of concentricity of dumb bells (0.6 mm); therefore the new configuration can be accepted with confidence.

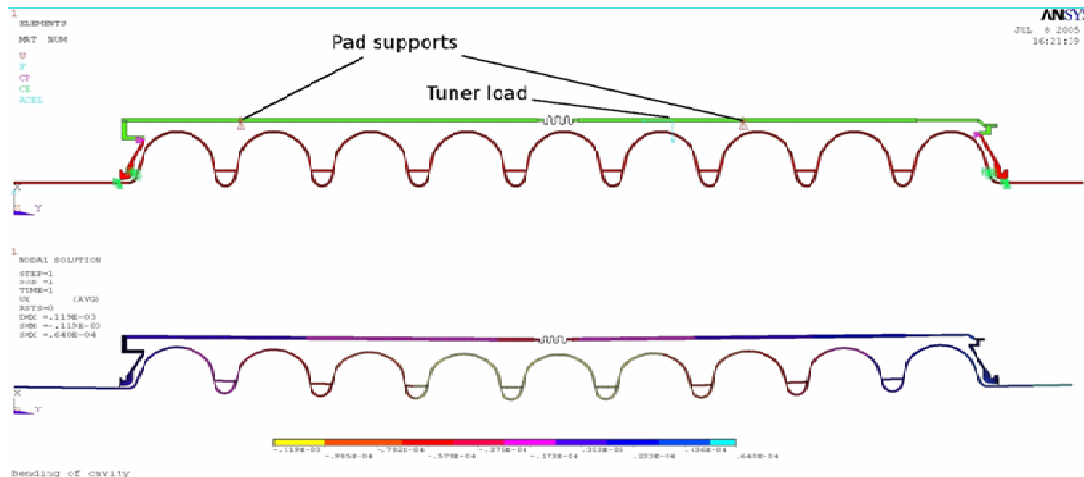


Figure JRA1.8.3: FEA evaluation of the cavity vertical displacement.

In parallel to the tuner design and construction, the activity of piezo characterization is still in progress. A load cell working in a LHe environment has been designed and successfully tested. The purpose of this device is the measurement of the pre-load force to be applied to piezoelectric ceramics placed in fast tuners, application of the correct pre-load value being mandatory in order to maximize their lifetime. The test on a prototype, built by the Italian firm CELMI, has proved that the glue and strain gauge sensors used *can work* in LHe cryogenic environment with good *repeatability* and *sensitivity*. In Figure JRA1.8.4 you can see the load cell calibration curve, showing good linear behaviour.

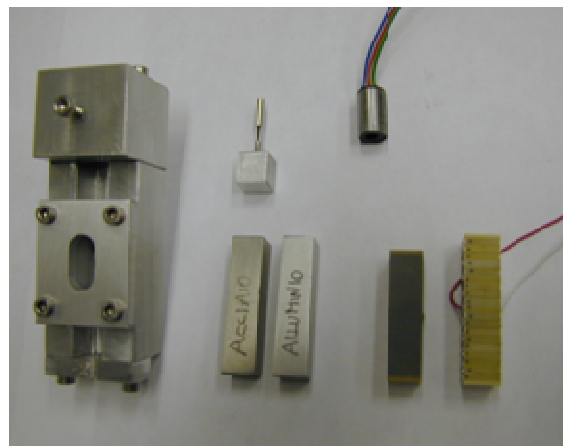
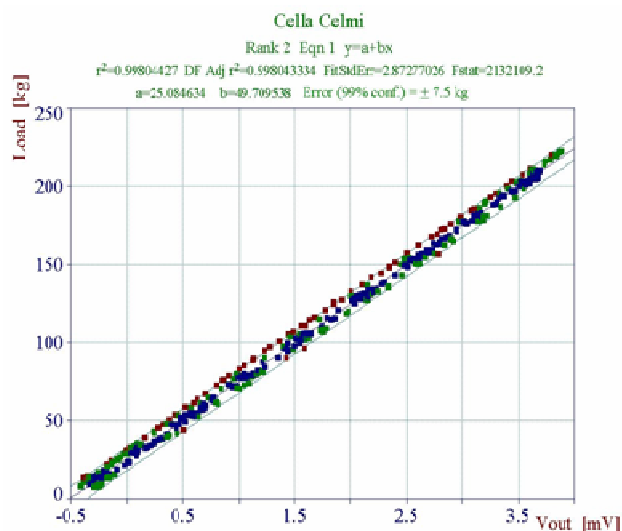


Figure JRA1.8.4. Cryogenic load cell calibration      Figure JRA1.8.5: Device for measuring piezo shrinking in cryogenic environment

A lifetime test has been performed on a piezoceramic stack. The purpose of this test is to investigate the behaviour of piezoelectric ceramics in conditions equivalent to 10 years of operation as an actuator in active frequency tuners for ILC superconducting cavities. To do this a Physik Instrumente PI P-888.90 PIC255 piezoelectric actuator has been cooled down in  $\text{LN}_2$  and has been excited uninterruptedly for a month up to its limits, sustaining about  $1.5 \cdot 10^9$  cycles of switching, up to nearly the maximum stroke. After this working period in an extreme working environment, the PI P 888.90 piezo is still working fine and shows almost the same characteristics as measured before the test.

Other piezo properties such as thermal shrinking and the piezo working area (in terms of stroke and blocking force) at cryogenic temperatures are currently under investigation. In Figure JRA1.8.5 a device specially built for measurement of the thermal shrinkage is shown, based on the use of a LVDT position transducer and samples of well-known thermal shrinkages. Finally we are also making a great effort towards the use of the piezo itself as force sensor at cryogenic temperatures, calibrating some of its parameters (e.g.: capacitance and resonance frequencies) even involving the piezo modelling.

### JRA1.8.2 Magnetostrictive tuner (TUL)

The magnetostrictive tuner works in a LHe environment with success. It was tested in the vertical test stand, where the magnetostrictive tuner was assembled in series with a piezostack. The elongation of magnetic field driven actuator causes a shrinking of piezostack and as a consequence generation of a voltage, which was measured. The results were published at the MIXDES conference. To measure more precisely the elongation as a function of applied current to the coil, another test was designed. The detailed characterization of magnetostrictive rod is a main issue of the scheduled test. The experiment insert was planned (overview is shown below) and will be designed by IPN Orsay and fabricated in Poland or in France depending on the cost. The test will be performed at DESY.



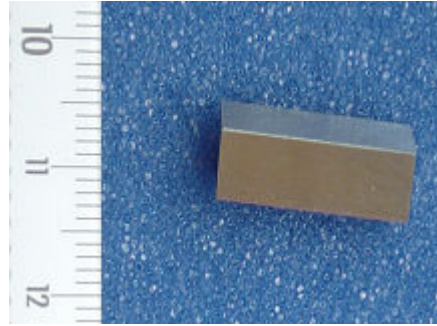


Figure JRA1.8.6: Magnetostrictive rod made of GALFENOL.

Three rods made of KELVIN ALL (1 rod) and GalFeNOL (2 rods – see Figure JRA1.8.6) materials will be evaluated. The latter material is expected to have poorer properties in LHe, but it is cheaper even than the piezostack. Especially the following parameters will be investigated:

- elongation versus applied current, (magnetostriction coefficient) and/or displacement versus magnetic field applied for different preload settings
- maximum stroke,
- slew rate of elongation (dynamics of motion),
- heat generation – the coil is made of Nb<sub>3</sub>Sn (critical temperature 18K),
- magnetic field distribution (if possible) – a proper sensor needs to be found,
- Young's modulus of the magnetostrictive rod

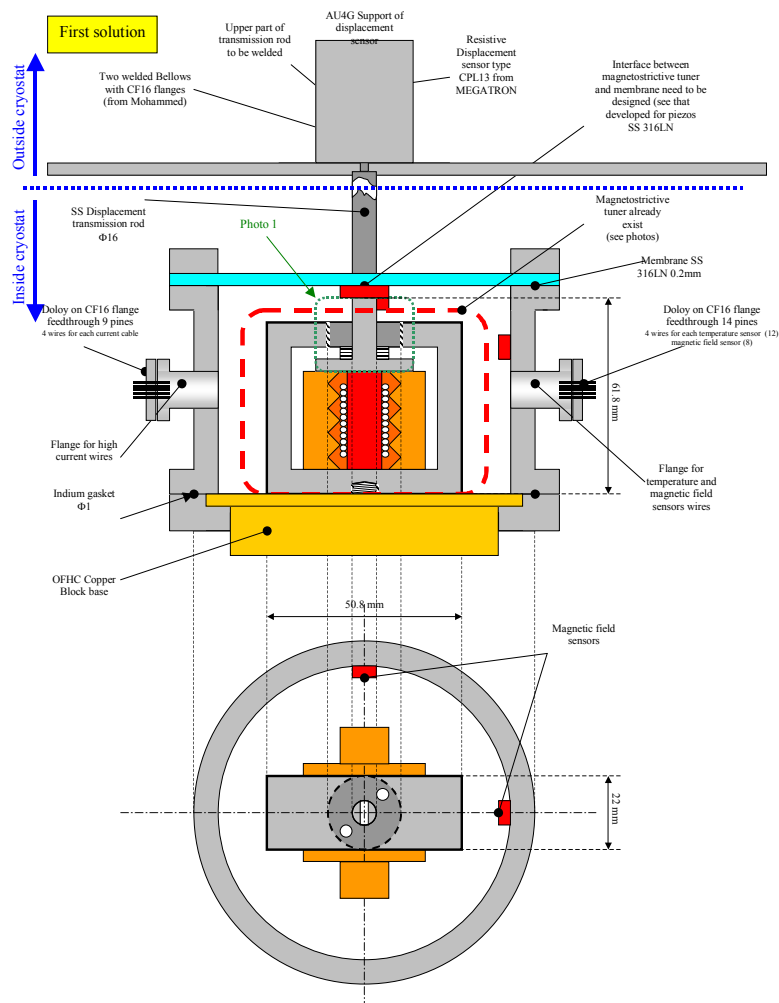


Figure JRA1.8.7: Overview of magnetostrictive element characterization experiment.



Lastly, there is a need to verify if the magnetostrictive rod might act as a force sensor. One much measure if this output current can be achieved when the rod is stressed.

The detailed characterization is slightly delayed due to the fabrication process of a proper insert box for the cryostat (see Figure JRA1.8.7). However, we decided to perform the test with cavity as scheduled.

Furthermore, some minor modification has been made to the tuner itself (the mechanical fixture has been changed to fit the new helium tank).

There is also further research on a driver for the magnetostrictive element. Mainly, the reliability is improved (due to the high power supplied to the active element the temperature distribution in the amplifier is a concern). However the current electronic system allows us to operate the magnetostrictive elements in pulse mode with settings similar to those at which the piezoelectric element is running.

### JRA1.8.3 CEA tuner (CEA)

Two double piezo tuners were designed and fabricated in the framework of CARE/SRF (see Figure JRA1.8.8). These new tuners were designed in such a way that they can be mounted on the present TTF cavities and cryomodules without any modification.

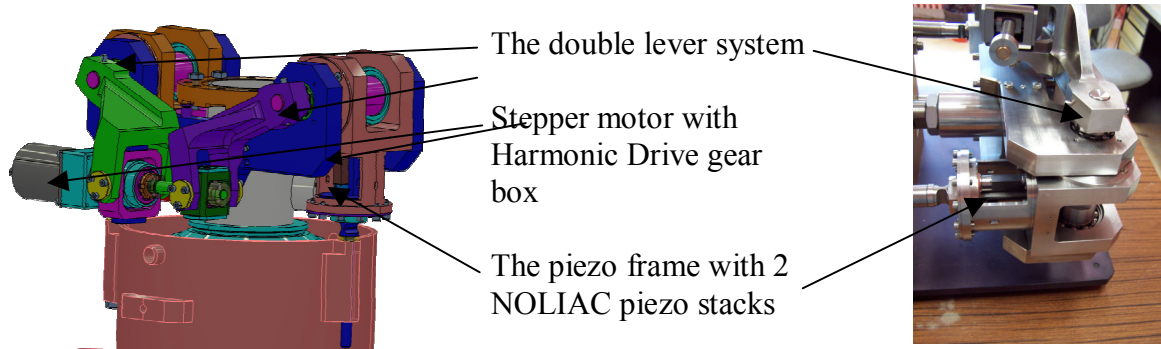


Figure JRA1.8.8. Overview of Piezo Tuner System (PTS) designed in CEA-Saclay.

First tests of the tuners were performed at 300 K on a test bench and on the TTF C45 cavity during summer and autumn 2005 (Figures JRA1.8.9 and JRA1.8.10). The electronics was specially developed for the integrated experiments in CRYHOLAB as scheduled in WP10.



Figure JRA1.8.9: The measured stiffness on this test bench is 35 kN/mm limited by mechanical plays in ball bearing housings.



Figure JRA1.8.10: The piezo tuner is mounted on C45 TTF cavity with the electronics in the laboratory.

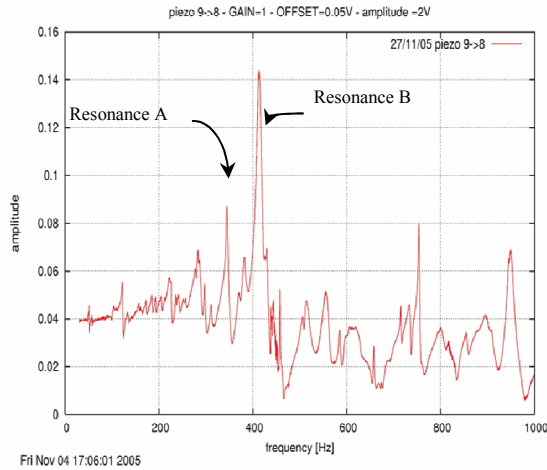
Commissioning of the C45 TTF cavity power coupler was performed in CRYHOLAB before mounting the piezo tuner (WP10 work package). This commissioning demonstrated a limit of the maximum gradient at 18 MV/m available with  $P_{\max} = 950$  MW in pulsed mode of 205  $\mu$ s with 0.88 Hz repetition rate.

After RF power coupler commissioning and piezo tuner tests at 300 K, the cavity, fully equipped, was mounted in CRYHOLAB for integrated tests (Figure JRA1.8.11). Before cooling down, new measurements were performed at 300 K in this new environment, which are summarized in the following figures and curves.

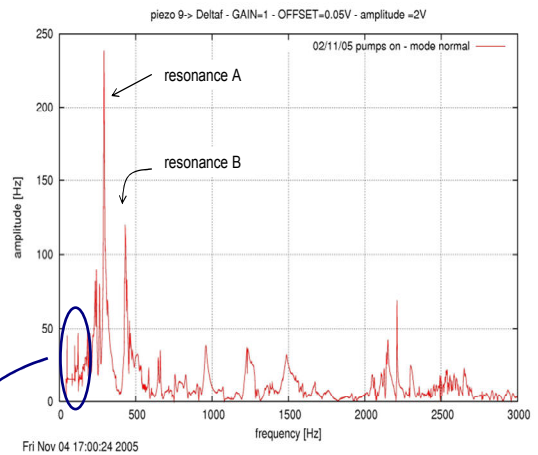


Figure JRA1.8.11: C45 TTF cavity in CRYHOLAB ready for integrated experiments. The electronics on the left allows characterization of mechanical modes of the cavity assembly: F, Q, piezo to piezo and piezo to frequency transfer functions.

Typical transfer function curves obtained at 300 K in CRYHOLAB are shown in the figures JRA1.8.12.



Piezo to piezo transfer function



Piezo to frequency transfer function

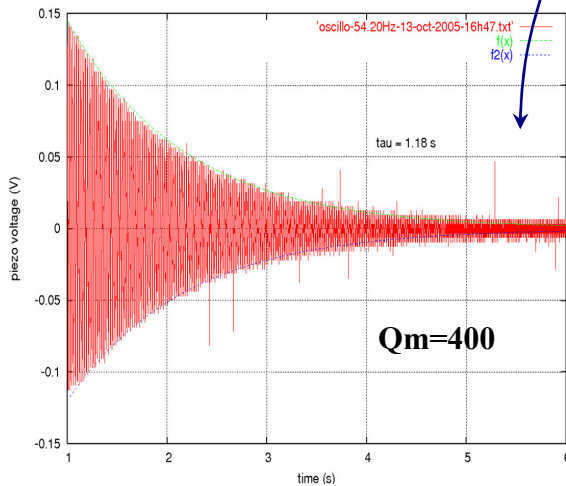


Figure JRA1.8.12: Comparison of these 2 curves shows the relative effect on the cavity frequency of the different mechanical modes detected by the piezo sensor. For example vibrations at around 400 Hz have less effect than the one at around 330 Hz. The Q value of the resonant mode at 54.2 Hz calculated with the exponential decreasing time  $\tau=1.18$  s shows high Q mechanical resonance

After cooling down, the transfer functions are modified. This is shown in the following curve corresponding to the piezo to piezo transfer function obtained at 4.2 K (Figure JRA1.8.13).

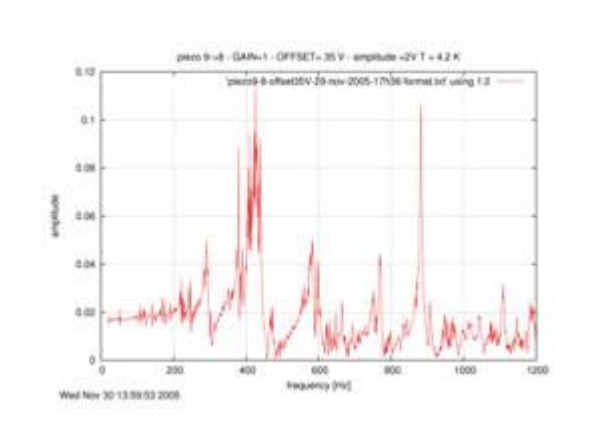


Figure JRA1.8.13: Piezo to frequency transfer function is in progress and cannot be presented in this report.

The preparation of the integrated experiment in CRYHOLAB is in progress. A last refinement in the electronics is still needed for beginning the experiments of Lorentz force compensation which should be operational during future weeks.

These experiments are being performed with NOLIAC PZT29 stacks 30mm long. Future experiments in CRYHOLAB are foreseen at the beginning of year 2006 with the same tuner mounted with PI piezostacks (40 mm long) characterized by IPN-Orsay (task 8.4).

**JRA1.8.4 IN2P3 activities (CNRS-Orsay)**

The activities of IPN Orsay for the task 8.4 continue. Most items of IN2P3 tasks for WP 8 are nearly completed: the corresponding results were reported in different conferences. Several piezoelectric actuators from three different companies were fully characterized at low temperature (e.g. full range displacement, dielectric and thermal properties). Radiation hardness tests with fast neutrons at low temperature (4.2 K – 300 K) were successfully performed. Three beam tests were carried out with three types of piezostacks: we tested four piezo elements of PICMA type from PI, four of NOLIAC type and three of the JENA type from PIEZOSYSTEM JENA. The photographs of the experimental device and typical results are presented in Figure JRA1.8.14.

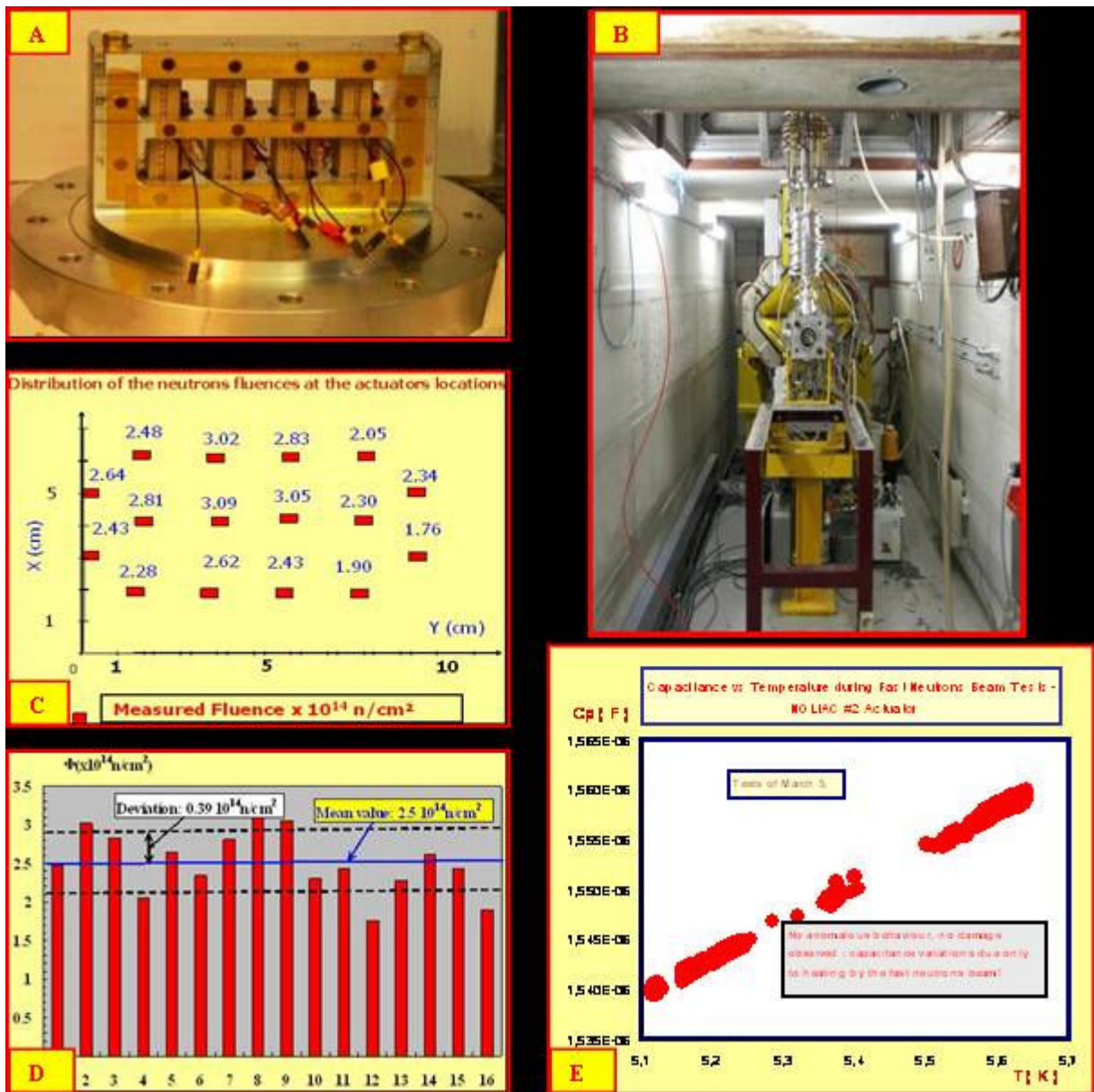


Figure JRA1.8.14. Irradiation test experiment: A) Test-cell : actuators equipped with nickel foils, B) Insert of the cryostat in front of the beam line, C) Map of the measured neutrons influence, D) Neutrons influence distribution, E) Actuator capacitance versus temperature.



Moreover, a preliminary room temperature measurement of resonant spectrum as function of the preloading force applied to piezostacks was successfully performed. Finally, a new experimental set-up dedicated to the study of preloading effect on the piezostacks electromechanical behavior at low temperature was developed and successfully tested: the main results are illustrated in Figure JRA1.8.15 and Figure JRA1.8.16. The sensitivity  $dC_p/dF$  of the piezoelectric actuator to preloading force  $F$  ( $F=733\div 4022$  N) was measured in the temperature range  $T = 1.68\div 300$  K:  $dC_p/dF$  decreases monotonically with  $T$  from  $426\text{nF/kN}$  @  $T=295$  K down to  $16\text{nF/kN}$  @  $T=1.7$  K.

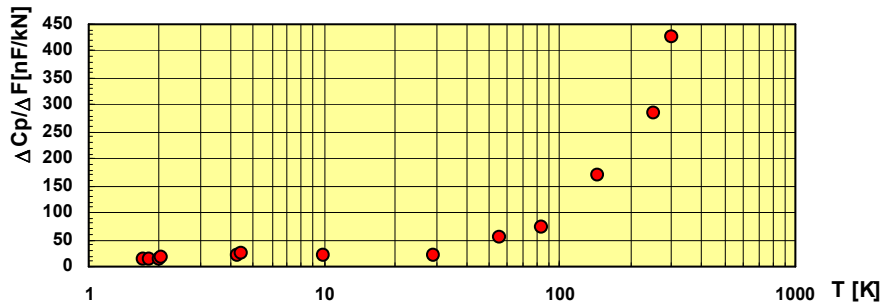


Figure JRA1.8.15: Sensitivity of piezoelectric actuator to preload force versus temperature

In addition, the actuator capacitance increases linearly with the preloading force in the range 0.7kN- 4kN, at a given temperature (see Figure JRA1.8.16): the linear behaviour was observed in the whole temperature range (1.7 K- 300 K). Finally, a piezoelectric actuator was tested for its use as a force sensor at low temperature (i.e. capacitance variation, transient voltage, etc). A detailed report concerning this study is under preparation.

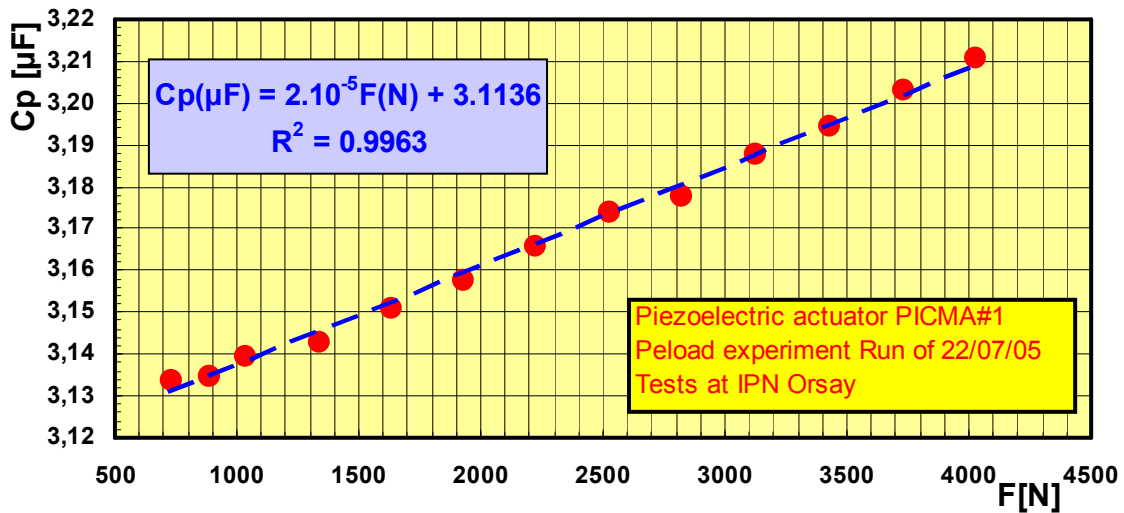


Figure JRA1.8.16. Piezoelectric actuator capacitance versus preloading force at  $T=4.4$  K, vacuum pressure  $10^{-5}$  mBar.

### JRA1.8.5 Overall Progress of Work Package 8

The following table highlights the progress of work planned in the year 2005 for the Work Package WP8 by listing the lowest level subtasks of the SRF detailed implementation plan.

N°	Task Name	MS, Deliverable	Contractor	% aschlo	2005				2006	
					1.Q05	2.Q05	3.Q05	4.Q05	1.Q06	2.Q06
<b>8</b>	<b>WP8 TUNERS</b>			<b>56%</b>						
<b>8.1</b>	<b>UMI TUNER</b>		<b>INFN-Mi</b>	<b>41%</b>						
8.1.1	Control electronics		INFN-Mi	100%						
8.1.2	Mechanical tuner design, leverage system/motor		INFN-Mi	100%						
8.1.3	Integration piezo design		INFN-Mi	100%						
8.1.4	Choice of transducer/actuator		INFN-Mi	100%						
8.1.5	<b>Report UMI tuner</b>	<b>Design repor</b>	INFN-Mi	100%						
8.1.6	Tuner fabrication		INFN-Mi	70%						
8.1.7	Piezo fabrication and bench tests		INFN-Mi	0%						
8.1.8	Cavity-tuner-coupler integration		INFN-Mi	0%						
8.1.9	Pulsed RF tests		INFN-Mi	0%						
8.1.10	<b>Evaluation of tuner operation</b>	<b>Final Report</b>	INFN-Mi	0%						
<b>8.2</b>	<b>Magneto-strictive Tuner</b>		<b>TUL</b>	<b>61%</b>						
8.2.1	Complete specification		TUL	100%						
8.2.2	Conceptual design		TUL	100%						
8.2.3	Prototype and performance evaluation		TUL	95%						
8.2.4	Finalize tuner and drive electronics design		TUL	100%						
8.2.5	Test of tuner		TUL	25%						
8.2.6	<b>Report on magneto-strictive Tuner</b>	<b>Status repor</b>	TUL	0%						
<b>8.3</b>	<b>CEA Tuner</b>		<b>CEA</b>	<b>99%</b>						
8.3.1	Design Piezo + Tuning System		CEA	100%						
8.3.2	Fabrication		CEA	100%						
8.3.3	Installation RF		CEA	100%						
8.3.4	<b>Start of Integrated Experiments</b>	<b>Tuner Prototyp</b>	CEA	70%						
<b>8.4</b>	<b>IN2P3 Activity</b>		<b>CNRS-Orsay</b>	<b>68%</b>						
8.4.1	Characterize actuators/piezo-sensors at low temperature		CNRS-Orsay	100%						
8.4.2	Report on actuator/piezo sensor		CNRS-Orsay	80%						
8.4.3	Test radiation hardness of piezo tuners		CNRS-Orsay	100%						
8.4.4	Report on radiation hardness tests		CNRS-Orsay	80%						
8.4.5	Integration of piezo and cold tuner		CNRS-Orsay	100%						
8.4.6	Cryostat tests		CNRS-Orsay	20%						
8.4.7	Tests with pulsed RF		CNRS-Orsay	0%						
8.4.8	<b>Report on IN2P3 tuner activities</b>	<b>Final Report</b>	CNRS-Orsay	30%						

WP8



## JRA1.9 Work Package 9: Low Level RF (LLRF)

### JRA1.9.1 Operability and technical performance

#### *JRA1.9.1.1 Transient detector*

Progress: In line with schedule.

The goal of beam induced transient detection is to make beam phase measurements with respect to the RF field in the cavity and also to measure transient magnitudes during normal accelerator operation with beam charges from 0.5 nC. This allows us to make easy and safe calibration and to monitor beam phase.

Since the beginning of 2005 large changes to the system have been made. The tests performed in January have proved that the applied method operates properly (<http://ttfinfo.desy.de/LLRFelog/LLRFelog/data/2005/04 - 24.01.2005>) and gives correct values.

During the past year transient detection system was re-designed and rebuilt focusing on automation and operability. Now it can be controlled remotely via aDOOCS interface and can be calibrated automatically. The performed tests have shown that the system operates correctly (information about performed tests is available in the TTF electronic log-book). Some design and data processing errors were found and fixed. A summary of the work done is presented below.

Completed hardware:

- Filter for transient detection
  - o RF transient detection filter
  - o Control circuitry for filter
- Circuitry for remote control of transient detection system
  - o integration of the control system boards into VME crate with embedded SUN Sparc
  - o DOOCS servers for ADC module, DAC module and digital IO module,
- Vector detector based on "the law of cosines"
- VME board with low noise 80 dB variable gain amplifier
- VME board with signal distribution circuitry
- Automatic system calibration

Finished software:

- DOOCS server for transient detection
- DOOCS interface
- Matlab scripts for transient detection system control and transient measurement

The current system possesses the ability to measure single bunch transients with an accuracy of around 15 degrees at 1nC charge. This accuracy can be increased by averaging (Figure JRA1.9.2) Without averaging the peak to peak noise is around 35 degrees and with averaging of 30 samples this noise is reduced to roughly 7 degrees.

The system accuracy will be improved by thermal stabilization of the filter. The filter has a big influence on accuracy of measurements and it is also very temperature sensitive ([http://ttfinfo.desy.de/TTFelog/ - /TTFelog/data/2005/39/02.10\\_M - 02.10.2005 13:01](http://ttfinfo.desy.de/TTFelog/ - /TTFelog/data/2005/39/02.10_M - 02.10.2005 13:01)). The preliminary tests obtained with a thermally stabilized oven are presented in Figure JRA1.9.2. The phase drift was reduced from 20 degrees (without temperature stabilization) to about 2 degrees (with temperature stabilization).

Finally, the Transient Detection System will be installed in a thermally stabilized rack and additionally the RF transient detection filter will be mounted in a thermally stabilized oven (placed inside the thermally stabilized rack). Future plans also include improvement of the RF filter adjustment circuitry by replacing currently used circuit that has only one adjustment step with a circuit that has two adjustment steps for rough and precise tuning,

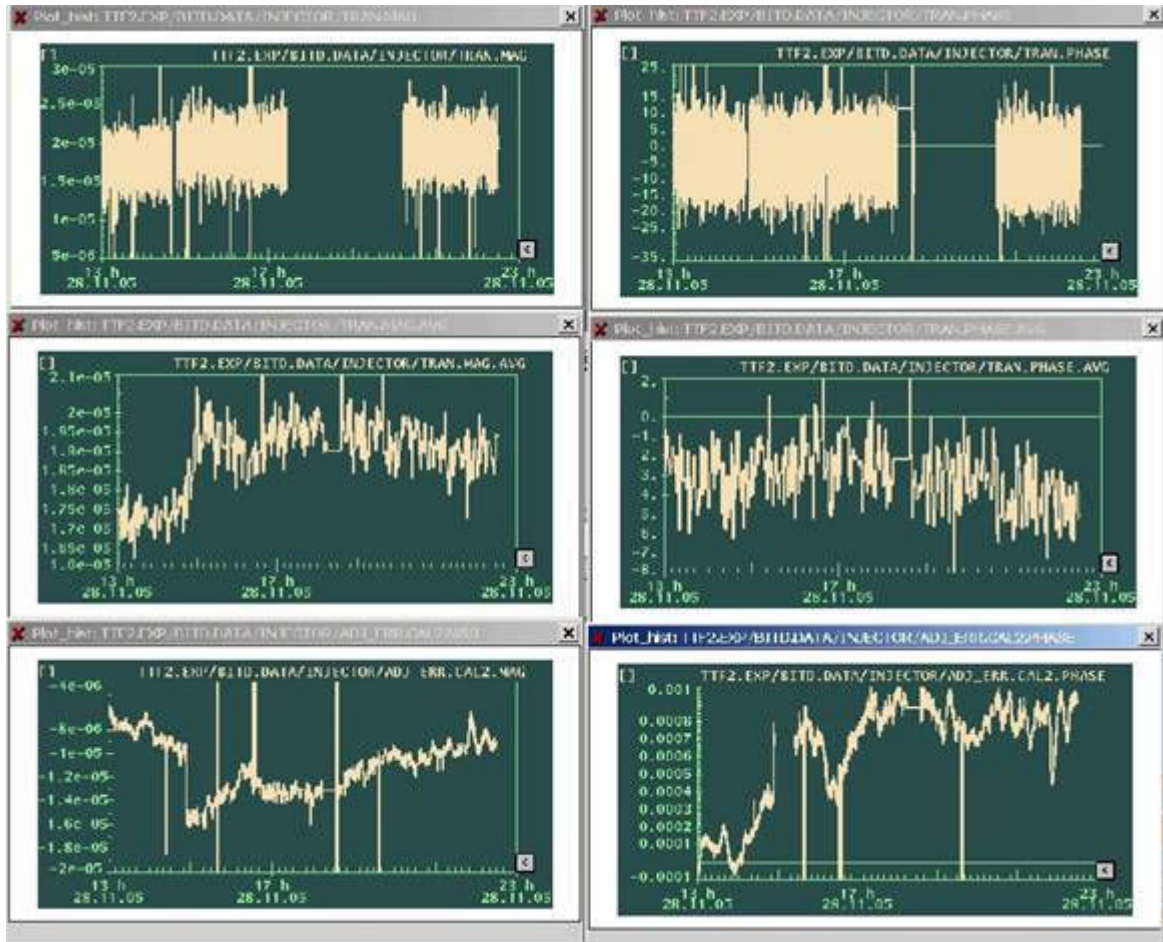


Figure JRA1.9.2: Transient detection system test with thermally stabilized oven.

Figure layout: top left - transient magnitude, top right - transient phase, middle left - transient magnitude after averaging of 30 samples, middle right - transient phase after averaging of 30 samples, bottom left - filter adjustment magnitude error, bottom right - filter adjustment phase error. Magnitudes are in relative units (absolute magnitude is divided by RF field magnitude), phases are presented in degrees.

Milestones and deliverables: None defined in the contract for this reporting period

Significant achievements and impact: accuracy improvement, integration of the system with operator panels

Deviations from schedule: None

### JRA1.9.1.2 LLRF Automation

#### Automation of RF-power station:

At the beginning of the year the monolithic solution was designed and was implemented as a single Finite State Machine. Unfortunately it turned that this solution grew cumbersome and

operation became difficult to test and maintain. Therefore the design had to be changed. It was decided to split the design into two functional parts:

**Exception handling part:**

We implemented a set of decision tables, which “listen” to the environment constituted by DOOCS servers monitoring RF-power station parameters. The main purpose of these structures is to recognize and classify specific patterns of DOOCS signals, which can be called exceptions. If an exception is recognized it is marked with two identifiers (class and unique ID). There are three different classes of exceptions (errors, warnings and actions). The ID is a unique identifier allowing one to ascribe actions human readable descriptions and corresponding procedures (only in case of actions).

After recognition an event is passed to the proper input buffer. For each class of the event one input buffer has been implemented. After being placed in the buffer, the event is picked up by the simple automat. This element takes care of further event processing.

**Operator assistance:**

Due to the fact that the exception-handling mechanism takes over responsibility for many functions which formerly the FSM dealt with the schematic of the FSM, driving a single RF-power station, has become greatly simplified and hopefully much easier to understand, *test and maintain*.

**Current status of present design:**

The operator’s FSM has been implemented and incorporated into the DOOCS environment. It was provisionally tested (without connection with exception handling mechanism), and proved its usefulness. After a few corrections it was able to drive the RF-power station according to the pre-configured program.

The exception handling design is under development. Its main parts, a set of decision tables, buffers and exception handling automata, have been elaborated but have not been yet combined and tested together.

Applications:

- High power chain linearization.

In order to improve control efficiency of the LLRF system an application for linearization of the high power microwave klystron is necessary.

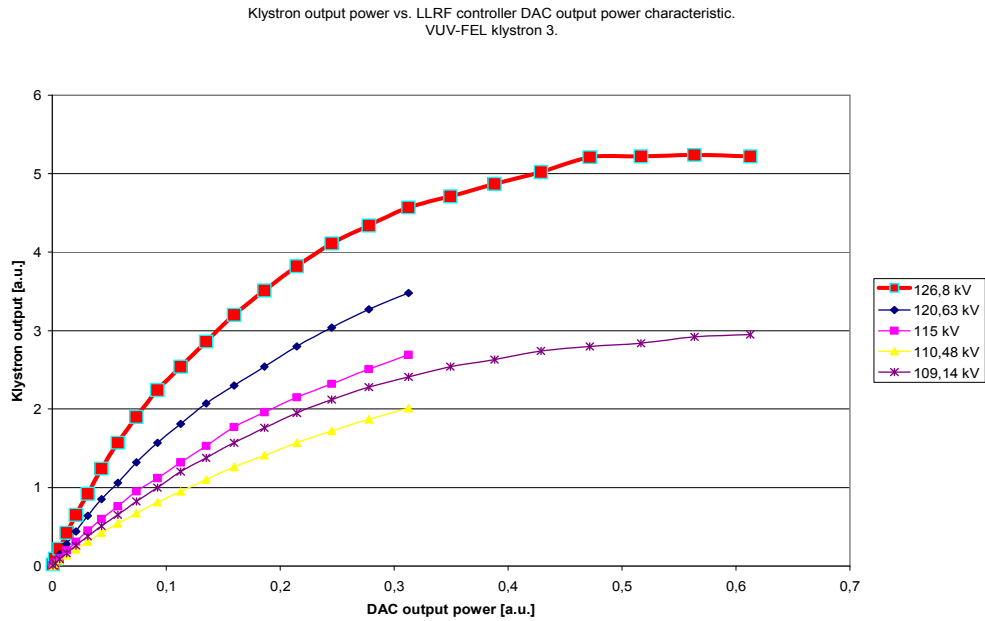


Figure JRA1.9.2: The klystron saturation phenomena in one of the VUV-FEL klystrons.

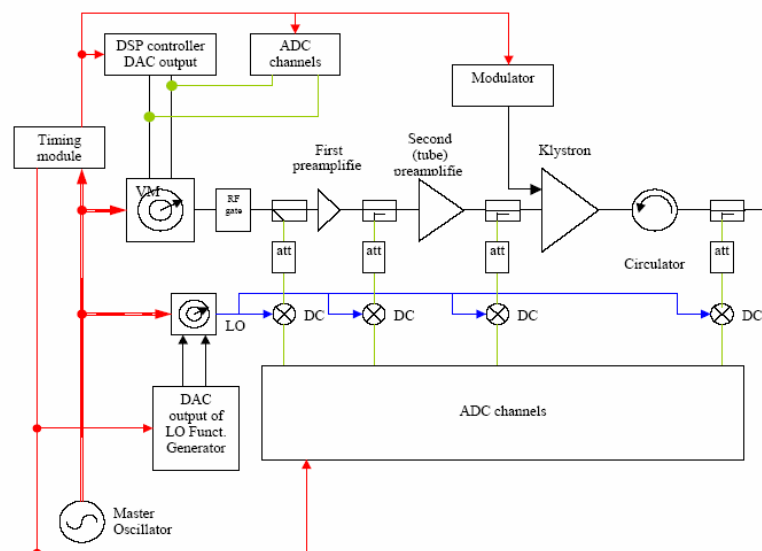


Figure JRA1.9.3: Monitoring point (diagnostic) configuration for RF stations in the VUV-FEL. Data available from ADC channels is stored in the DOOCS environment and is used for further processing.

To choose the linearization method which will fit in the present and future system requirements one has to examine the nature and quantity of the distortions introduced by the high power pulsed klystron. A monitoring point network needed for high power chain (HPC) component non-linearity diagnostics has been proposed and established for some of the VUV-FEL RF stations. To characterize the nonlinearities of the HPC components a dedicated software tool created in Matlab was developed. Using proposed configuration and tool a number of studies (concerning response of the system for the different working parameters, nonlinearity detection, slow time drifts and estimated phase errors induced by the components) were performed for one of the VUV-FEL RF stations. Based on results achieved from present and forthcoming measurements, and taking into consideration the existing structure of the whole LLRF station as well as the system requirements, a linearization method for the klystron will be proposed. The most promising approach (from those available on the

market) is linearization of the high power amplifier chain using an RF pre-distorter solution, especially complex vector mapping.

In addition, work on the software tool that will estimate nonlinearities of the klystron and the other HPC components in the vicinity of the whole LLRF station operating point is under development and in the test phase.

- Bouncer performance optimisation.

A very important issue that concerns also the klystron contribution to the whole superconducting module work performance is the high voltage pulse supply stability. As a change of the klystron HV level (eg. during the pulse) causes klystron output-signal phase instability, some compensation is compulsory. The Matlab tool (that co-operates with the DOOCS environment) is in the test phase for optimization of the bouncer system triggering. Use of this tool during the regular machine operation will improve timing settings of the HV pulse shaping system for better voltage pulse slope cancellation during the signal plateau.

Progress: In line with schedule.

Milestones and deliverables: None for the reporting period.

Significant achievements and impact: FSM development and klystron linearization.

Deviations from schedule: None.

*JRA1.9.1.3 Control Optimization*

Control Performance has been studied with a spread in operational gradients. Results indicate that with adjustment of loaded Q, incident phase, and fixed detuning during the pulse a spread of up to 5% can be accepted. Higher spreads can be reduced to about 5%. However with freely programmable time varying de-tuning during the rf pulse, the gradient spread can be completely recovered and each cavity can be operated at its maximum operable gradient. The limitations in power and limited range of tuners for loaded Q, incident phase and cavity detuning suggest a possible range of +/- 20% in gradient spread. A few percent of the average gradient may be lost by limitations in fast detuning control due to the mechanical resonances of the cavities. This requires further investigation.

Progress: In line with schedule.

Milestones and deliverables: None for the reporting period.

Deviations from schedule: None

**JRA1.9.2 LLRF cost and reliability**

*JRA1.9.2.1 Cost and reliability study*

Cost reduction by integration of down-converters with analog to digital converters and pre-processing of data locally in FPGA (partial vector-sum) have been discussed. The down-converters could be placed close to the cryomodules (RF patch panel) and partial vector-sums could be sent with optical Gigalink interfaces to the main processing unit. This would result in significant saving in temperature stabilized RF cables.

The reliability of one RF station has been estimated. Assuming that the LLRF system consists of 9 crates from which 3 are critical for operation and that these crates have a MTBF of 100,000 hours, one would expect one RF station failure (out of 30 stations) every 4 months. With the redundant feed-forward the overall failure rate would be then only one failure every 3 years. This assumes that feedback and redundant feed-forward would fail in the same month.

Progress: In line with schedule.

Milestones and deliverables: None for the reporting period.

Deviations from schedule: None

#### JRA1.9.2.2 Radiation damage study

A dedicated system for neutron fluence and gamma radiation monitoring in real-time was installed on the VUV-FEL. The system was equipped with a SRAM-based neutron detector, for which the operation is based on counting parasitic Single Event UpSet (SEU) generated in SRAM device by neutrons. The detector is connected to radiation tolerant read-out system; therefore the whole system can be installed in a radioactive environment.

A series of experiments were carried out to determine the memory the most sensitive to neutrons. The 512 kB Samsung memory, which has the highest sensitivity factor  $S$ , was finally chosen as a neutron detector. The detector consists of four K6T4008C1B-GB70 chips mounted on the small PCB board. The memories are 11 times more sensitive than the 1 MB SRAM used before.

A supplementary cylindrical neutron moderator, made of polyethylene, was applied to assure a flat response of the SRAM-based detector to neutrons with energies up to tens of MeV. The dimension of the moderator was calculated using the MCNP 4A code. The neutrons passing through the moderator are thermalized. The construction of the moderator assures that enough thermal neutrons are produced to generate a flat response of the detector (taking into consideration neutrons with energies up to tens of MeV). Application of a 9 cm moderator allows one to increase the sensitivity by approximately a factor of four.

Finally, the sensitivity to neutrons of the RadMon system was improved by a factor of 45. A comparison of sensitivities for two different memories: 1 MB and 4x512-kB-stacked detector, with and without moderator is presented in Figure JRA1.9.4.

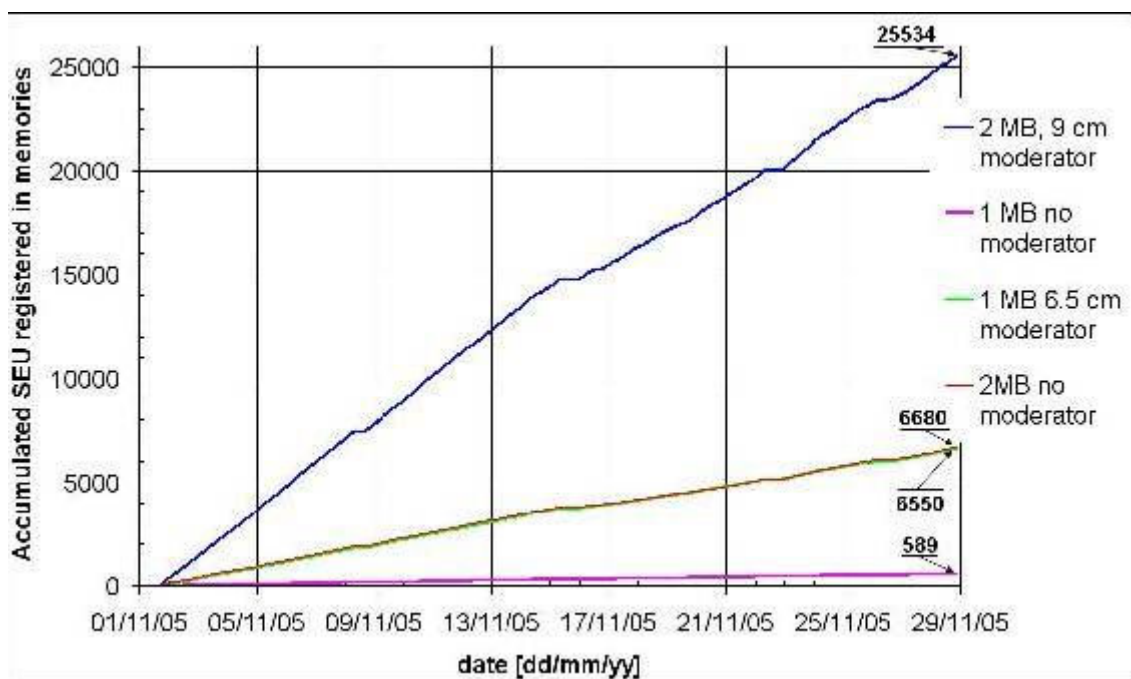


Figure JRA1.9.4: A comparison of SRAM devices.



The accumulated dose was collected within one month. The memories were calibrated using a  $^{241}\text{AmBe}$  (n,  $\alpha$ ) source. Moreover, a preliminary, in-situ, calibration was carried out in the VUV-FEL tunnel. One SEU generated in memory corresponds to  $256000 \text{ n}\cdot\text{cm}^{-2}$ .

The dose of gamma radiation produced in the accelerator is substantial therefore it is important to measure the radiation in real-time also. A RadFET-radiation sensitive Field Effect Transistor was used to measure gamma radiation. Figure 9.5 presents the accumulated dose of the gamma radiation and neutron fluence measured in VUV-FEL tunnel during November 2005. It is worth mentioning that the characteristic is flat for a few hours every Tuesday - this is the VUV-FEL maintenance day and the accelerator is switched off. Therefore no radiation is produced.

According to the graph and the calibration the raw radiation dose produced during operation of the accelerator, gamma dose produced during one day, is estimated at 13.35 Gy and the neutron fluence is  $2.38 \cdot 10^8 \text{ n}\cdot\text{cm}^{-2}$ .

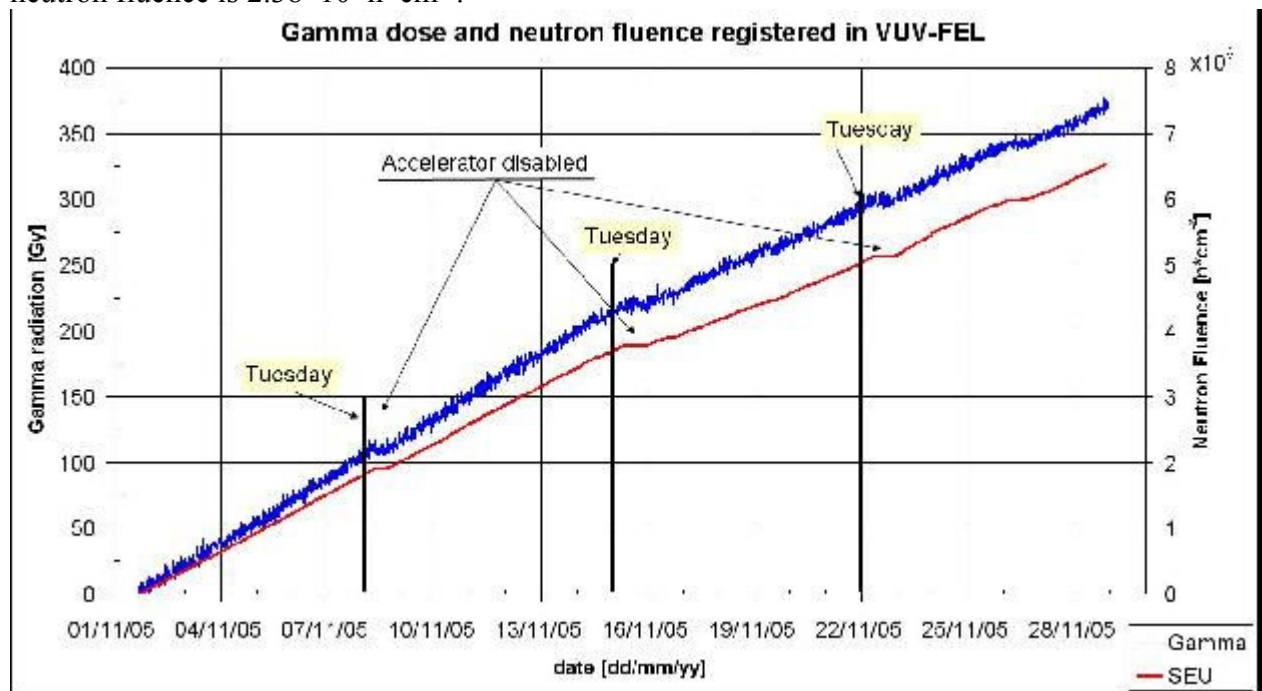


Figure JRA1.9.5: Neutron fluence and gamma radiation measured in VUV-FEL.

The measurements were carried out near the output of the first cavity module ACC1. Four RadMon systems are currently mounted on the concrete wall opposite module ACC1, see Figure JRA1.3 The data are accessible through a web-based interface (<http://neo.dmc.s.p.lodz.pl:9999/>).

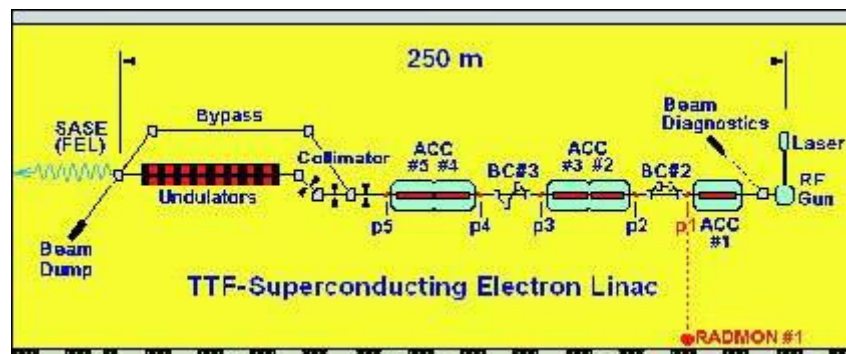


Figure JRA1.9.6: A view of the VUV-FEL cross-section with pointed out installed.

Some experiments were also performed with radiation tolerant software algorithms. The main aim was to design the fault tolerant operating system which should be able to work on standard computers architectures subjected to the radiation impact.

The modified sCore operating system is used for research. It provides an indispensable functionality such as pre-emptive multi-tasking environment. The sCore kernel was changed to provide software redundancy. The special process, called EDAC task, was built in sCore (fig. JRA1.9.7). The system memory is divided by EDAC task into three parts: program memory and two copies. The EDAC task is run periodically by the sCore scheduler (Round Robin algorithm). The system memory is checked by the EDAC task and compared with one of the copies. If any difference occurs the EDAC task chooses a valid data and copies it to the system memory region.

Two experiments were conducted at DESY that showed the impact of radiation on the software part of the computer system. Checking the effectiveness of the EDAC Task algorithm was the main aim of both experiments. A software redundancy (EDAC Task) can be very efficient and reliable when microprocessor system is subjected to weak radiation and a small number of SEU events which was confirmed by the results of the experiment with the 241AmBe neutron source. The experiment conducted inside the Linac II tunnel opposite to the electron-positron converter proved that strong radiation source generates SEUs not only in the main memory but also in registers inside CPU. The EDAC Task can not prevent SEU inside registers and its application is not sufficient for intense neutron radiation. Further development will utilise two or more microprocessors (e.g. PowerPC microprocessors embedded in Virtex2Pro FPGAs) working in parallel.

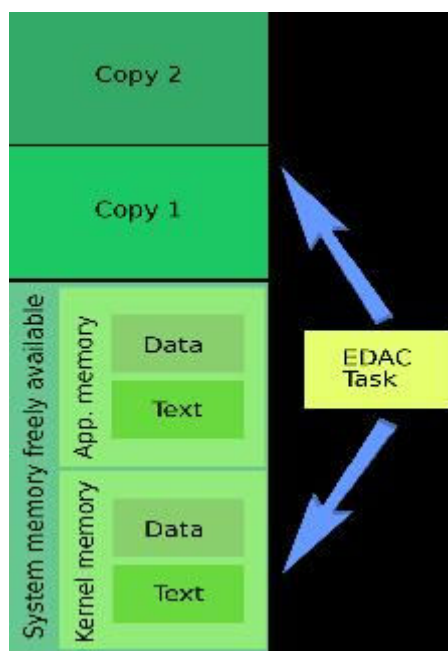


Fig JRA1.9.7: Memory protection using EDAC Task.

Milestones and deliverables: None defined in the contract for this period.

Significant achievements and impact:

- The most sensitive memory to neutrons was chosen.
- An additional moderator was designed to assure flat characteristics and increase sensitivity.
- Four RadMon systems were installed in the VUV-FEL, which represent a distributed system for on-line radiation monitoring.

- The data are collected in a database and accessible through www-based interface (next step is the handler for the DOOCS system).
- Patent application describing the system was made.

Deviations from schedule: None.

### JRA1.9.3 Hardware

#### JRA1.9.3.1 Multichannel downconverter

Based on the current state of design and realization of the RF Feedback System, in order to perform new frequency conversion down-converter unit project, a series of analysis were made, which were verified by calculations as well as practical realization of considered circuit solutions.

In a first stage of the conducted research a characterized frequency conversion process influence on parameter measurements of mapping signal of fluctuations in gradient and phase of the field in the cavity was defined, while taking into consideration current realization of the control loop parameters as well as algorithms which assure the stabilization of period of beam generation. At the next stage a maximum acceptable measuring error of change of gradient and phase values for a single measurement receiver for incoherent averaging in 32 cavity system was specified, the values of which are calculated by:

$$\Delta A_{\max} \leq 1,1892 \cdot (\sigma_E/E)_{RMS} , \Delta \varphi_{\max} \leq 0,5946 \cdot \pi^{-1} \cdot (\sigma_\varphi)_{RMS}$$

On the basis of above-mentioned dependences of frequency conversion system parameters were defined using a behavioral model. The primary factor that has an influence on stabilization gradient and phase value is dynamic range. However taking into consideration the distortion that results from nonlinear measurement receiver is Spurious-Free Dynamic Range (SFDR)[1]:

$$SFDR_{kaskady,dB} = \frac{2}{3} \left[ 3 - 10 \log \left( kTB \cdot \log \left( \frac{\sum_{i=1}^N 10^{\frac{NF_i}{10}} - 1}{\sum_{j=0}^{i-1} G_j} \right) \sum_{i=1}^N \left( IP3_i \prod_{j=i+1}^N G_j \right)^{-1} \right) \right]$$

Primary effect on possible acceptable phase fluctuation coefficient of field has complete additive total phase noise, which consists of internal phase noise for each frequency conversion stage, as well as master oscillator phase noise. The general form of phase noise level is given by [1]:

$$PN_{rms\_total} = \frac{180}{\pi} \left[ ADC PN_{rms}^2 + div PN_{rms}^2 + \left[ (2 - R_{\xi\eta}(t_{LO1}, t_{CLK1})) \right] 10^{\frac{k_{fo}}{20}} \cdot \left[ f_c \left( 1 + 10^{\frac{p}{10}} \right) + 2 \cdot 10^{\frac{p}{10}} \right] \cdot \left[ 10^{\frac{k_{fo}}{20} + \log N} + 10^{\frac{k_{fo}}{20} - \log M} \right] \right]^2 \right]^{\frac{1}{2}}$$

thus the distortion level of phase mapping in frequency conversion processing depends on the architecture of the conversion unit, fluctuation mapping techniques in digital form. The indirect coefficient that has an influence on fluctuation mapping accuracy on digital form of mapped signal of field in cavity is intermediate frequency value [1][2]. Along with the increase of intermediate frequency, the phase of mapping error also increases; as well as indirect influence on representation of instantaneous amplitude value, that results from SNR decrease.

On the basis of obtained results from a system analysis, a frequency conversion project was made for two different intermediate frequencies. An individual stage of conversion unit was designed (band-pass filter on 1,3GHz, band-pass filter on intermediate frequencies, couplers, intermediate frequency amplifiers, matching circuit for proposed double balance mixers, as well as matching circuits for ADC's).

On the basis of the defined parameters in the analysis process, the required ADC parameters were estimated, and one was selected from the available commercial models, using evaluation board for the measurement. For confirmation of conducted analysis a number of measurements of practical realization were made. As a result of conducted theoretical and practical research a design was specified and a solution with optimal conversion unit built on the basis of commercial components. The conducted number of research presents direction, in which further works needs to be done for obtaining the target stabilization parameters in the TTF2 project, as well as for future research in other control systems for EM field stabilization in cavity projects.

Progress: In line with schedule.

Milestones and deliverables: None for the reporting period.

Deviations from schedule: None.

#### *JRA1.9.3.2 Third generation RF control*

The new 3rd generation LLRF system called SIMCON3.1 is based on an Xilinx FPGA chip XC2VP30 Virtex-IIPro with 2 built-in processors and DSP blocks as a main control element. The board under development consists of 10 input analog broadband channels of 270 MHz and a voltage range of  $\pm 1$  V (matched to the wave impedance of 50  $\Omega$ ) as well as 4 DACs channels corresponding to ADC parameters. Several digital inputs and outputs are supplied for timing and triggering signals. The board is also equipped with a precision timing distribution system with a planned jitter performance of about 0.3 ps (RMS) and memory blocks – static, of capacity 512K of 36-bit words and dynamic, of capacity 128Mb and a word width of 32-bit for data storage.

The board is developed as a VME 6U card which can work also as stand-alone board using, for communication, additional interfaces like fast opto-giga-links with maximum throughput 2.125 Gbps as well as standard Ethernet 100Mbps link. A block diagram of this device is presented in figure JRA1.9.8.

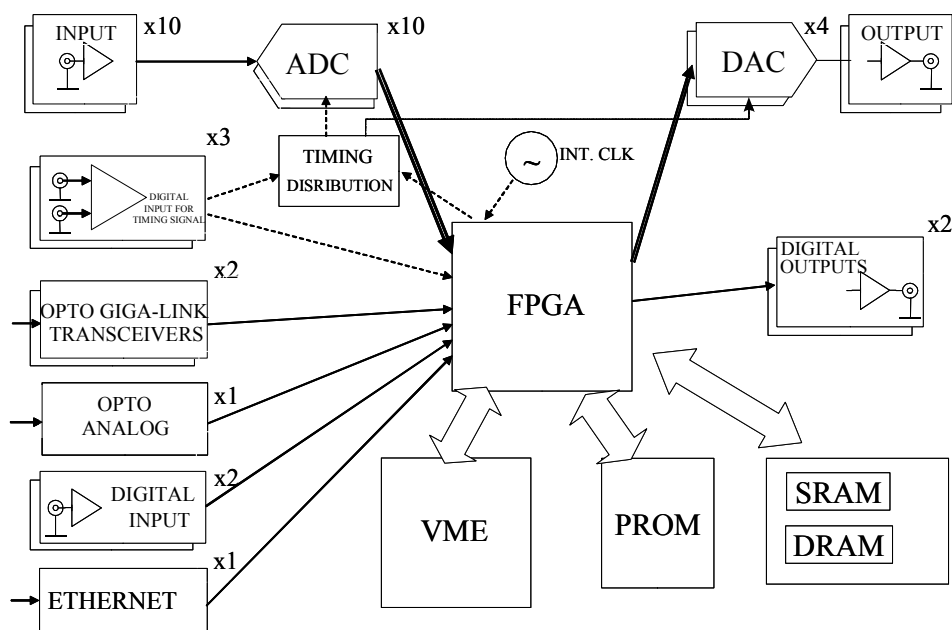


Figure JRA1.9.8: SIMCON3.1 block diagram.

The PCB board for the SIMCON3.1 device has two versions one of which is finished, debugged and currently under test. Eleven pieces of these boards have already been produced (figure JRA1.9.9).



Figure JRA1.9.9: One realisation of the SIMCON3.1 board.

The second version of SIMCON3.1 is still in the fabrication process.

FPGA board SIMCON 2.1 was successfully tested in CHECHIA in January 2005. The firmware, software and Matlab algorithm for controlling one superconducting cavity were tested with this board. A DOOCS server for the SIMCON 2.1 board was made.



New firmware for FPGA board called SIMCON 3.0 was tested. This firmware was written in VHDL and the idea was presented in quarter report 1-2005. An additional functionality is the detection of vector sum deviation and handler to it, which reduces the controller driving signals. Hardware and software of SIMCON 3.0 was tested on TTF2 on accelerating module ACC1. The tests were performed in May and September during LLRF studies. Module ACC1 of VUV-FEL accelerator in DESY was controlled by the SIMCON 3.0. The vector sum of field in eight cavities was stabilized. A proportional controller was used as a fast feedback loop. Figure JRA1.9.10 presents plots of the working system. A DOOCS server for SIMCON 3.0 board was made.

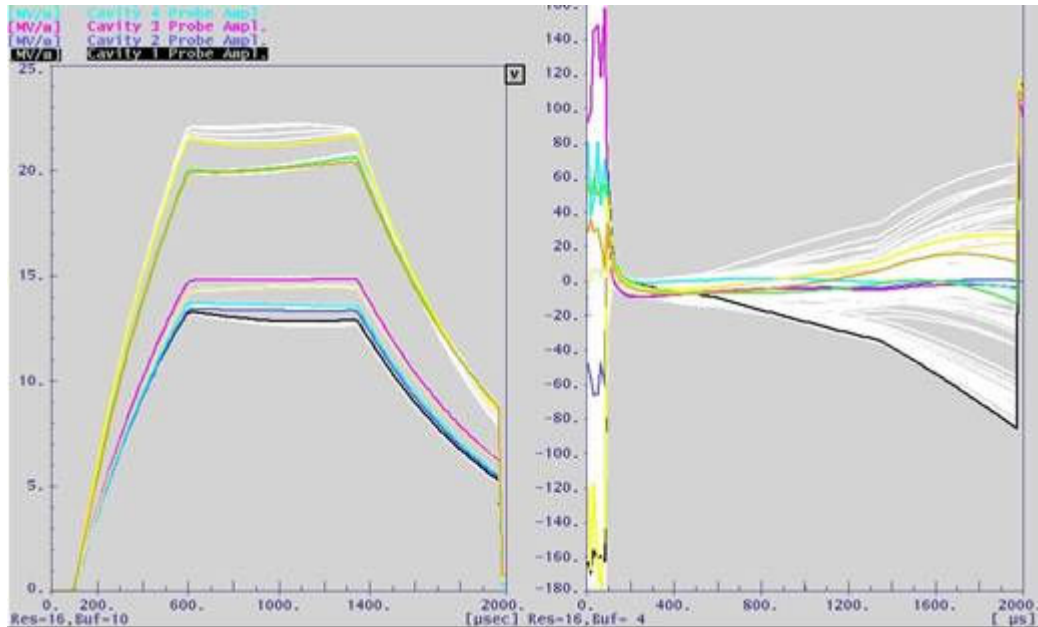


Figure JRA1.9.10: Amplitude and phase of eight cavities from ACC1 in VUV-FEL.



Figure JRA1.9.11: SIMCON3.0 ready for tests.



The firmware which was developed for SIMCON 3.0 was compiled and loaded to a new control board, SIMCON 3.1. The firmware works properly on SIMCON 3.1.

### JRA1.9.3.3 Stable frequency distribution

Progress:

New Master Oscillator:

Low power part: a lot of modules were redesigned in order to meet our specification; e.g. a new design for the 81 MHz and 108 MHz VCXO's including a power gain stage (1 W output) and four way power splitter at the output to eliminate phase drifts between outputs; low phase noise dividers in separate modules to minimize heating of individual modules due to their power dissipation, 9 MHz 1 W power amplifier and four way power splitter. Frequencies lower than 81 MHz (i.e. 27 MHz, 13,5 MHz, 9 MHz 1 MHz) are now derived from the 81 MHz master. A new block diagramme for the low power part was developed, the modules are wired according to this scheme, mounted onto a chassis and cabled. RF cabling was done using semi-rigid cables.

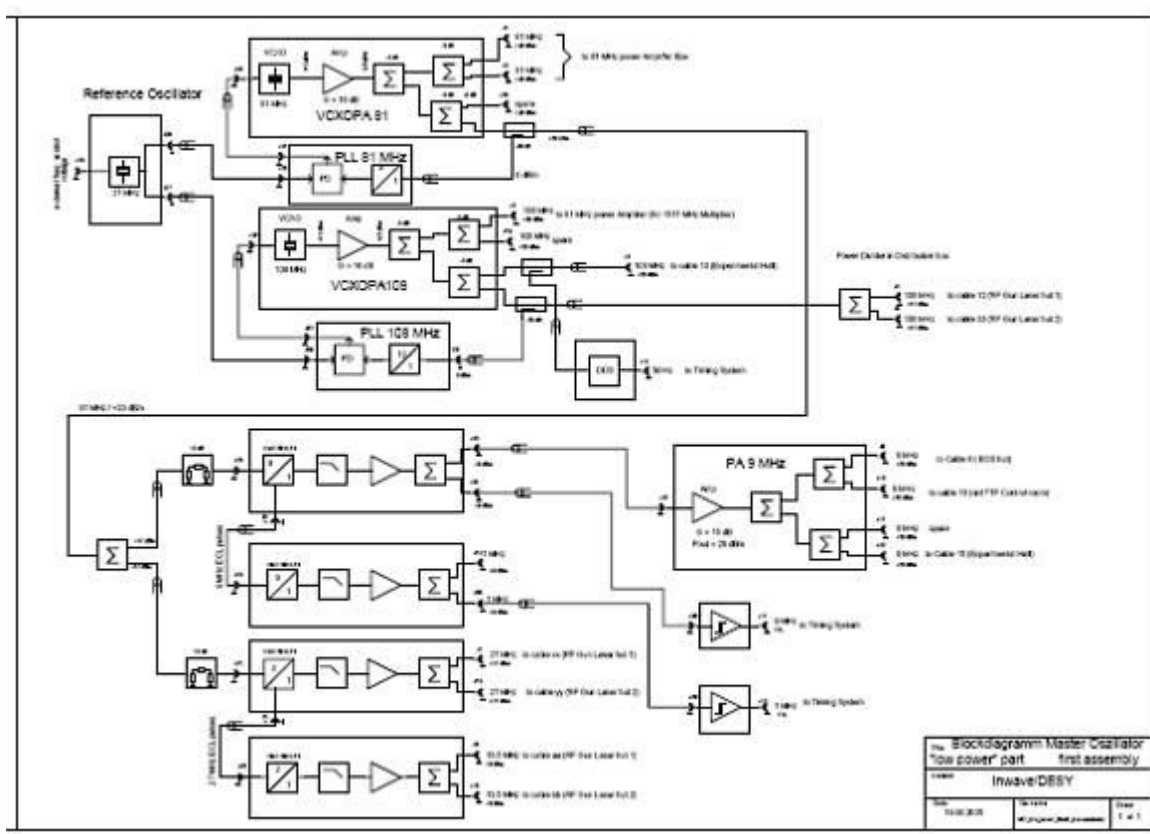


Figure JRA1.9.12: Block diagramme.

As the 9 MHz OCXO from MTI does not meet the specification given in their data sheet (but was the baseline for our specification), a 9 MHz OCXO from Wenzel Associated was ordered. The three delivered OCXO's had strong spurs at about 50 Hz offset from the carrier and therefore were sent back for repair. They arrived in August of this year.

A new scheme for generating 1.3 GHz and 2.856 GHz signals was developed using commercial, off the shelf, 2,488 GHz SAW based VCXO's mixing this frequency with a 112 MHz crystal oscillator, filtering and dividing the resultant 2.6 GHz signal by a factor of 2 and phase locking this 1.3 GHz signal to the 81 MHz reference frequency of the low power part. A similar scheme is used for generating 2.856 GHz.

The 1.3 GHz oscillator and PLL are housed in a separate crate and powered by a low noise power supply.

The required phase noise specification is not fulfilled. A DRO type oscillator is being developed at Warsaw University and Posidon Scientific Instruments.

High power part: amplifiers for 1.3 GHz and 81 MHz and associated monitoring circuitry were assembled into their 19" crates. The 1.3 GHz amplifiers do not meet the gain specification. Therefore, testing of different amplifiers with respect to gain, output power and phase drift are under test. New "customers" for the 81 MHz reference signal requested extra outputs, therefore the design of a new 81 MHz power part is taking place. For 81 MHz a new amplifier is under development.

### Frequency Distribution

Temperature control circuitry for stabilizing the temperature of the coaxial cables in the TTF II tunnel is installed and the controller is installed.

A phase stable fiber-optic frequency distribution link was installed and successfully tested in the TTF II environment. Stability requirements have been fulfilled but several problems and room for improvements were found. See figures JRA1.9.12 and JRA1.9.13 for example, results of measurements from an 11 day long measurement. Phase changes of three signals have been shown (system controller output, stable signal at the end of the link (after passing ~ 400 meters in the accelerator tunnel) and signal with no feedback applied, which passed the same way as the controlled signal).

In figures JRA1.9.13 and JRA1.9.14 one can observe that long term drifts have been significantly suppressed (one order of magnitude) in the stable signal compared to the signal with no feedback applied. Long term drift plots (1 hour range) in figure 2 show this effect more precisely. The obtained phase stability, 2 ps RMS, remains within the required 5 ps range but it can still be improved by solving a problem of asymmetric phase drifts observed in the system.

Unfortunately there was a problem with short term drifts (1 minute range). Due to problems with the phase shifter control, the short term stability of the controlled signal was a little poorer than the signal with no feedback. In both cases phase drifts do not exceed 0.6 ps RMS, which is less than the required 1 ps but here also there is room for improvement. Fortunately, reasons for short term drift problems were found. Improvements are in progress.

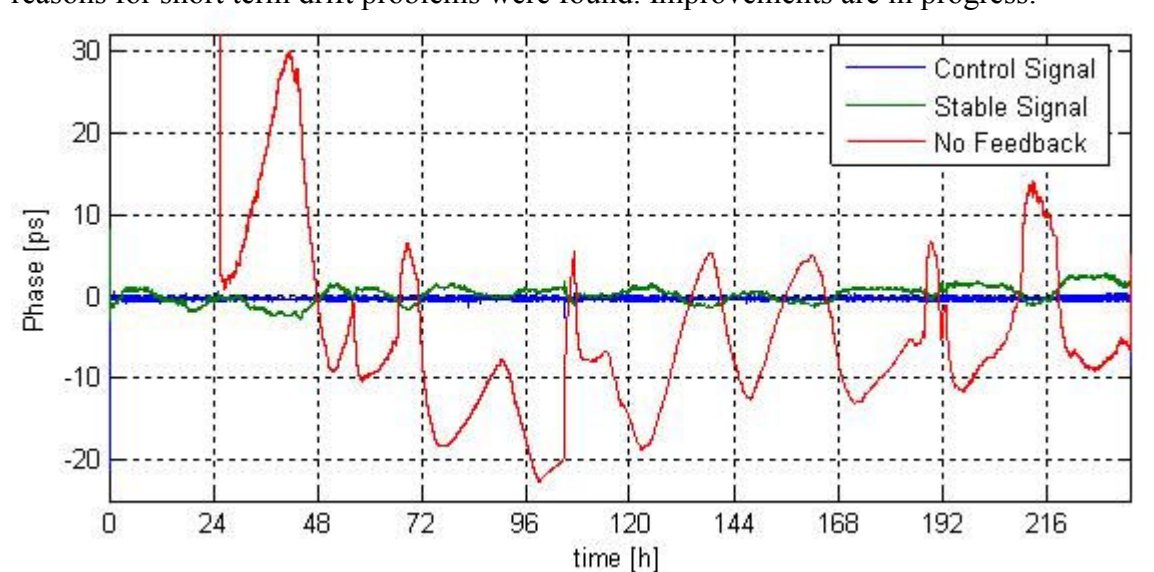


Figure JRA1.9.13: Phase drift measurement.

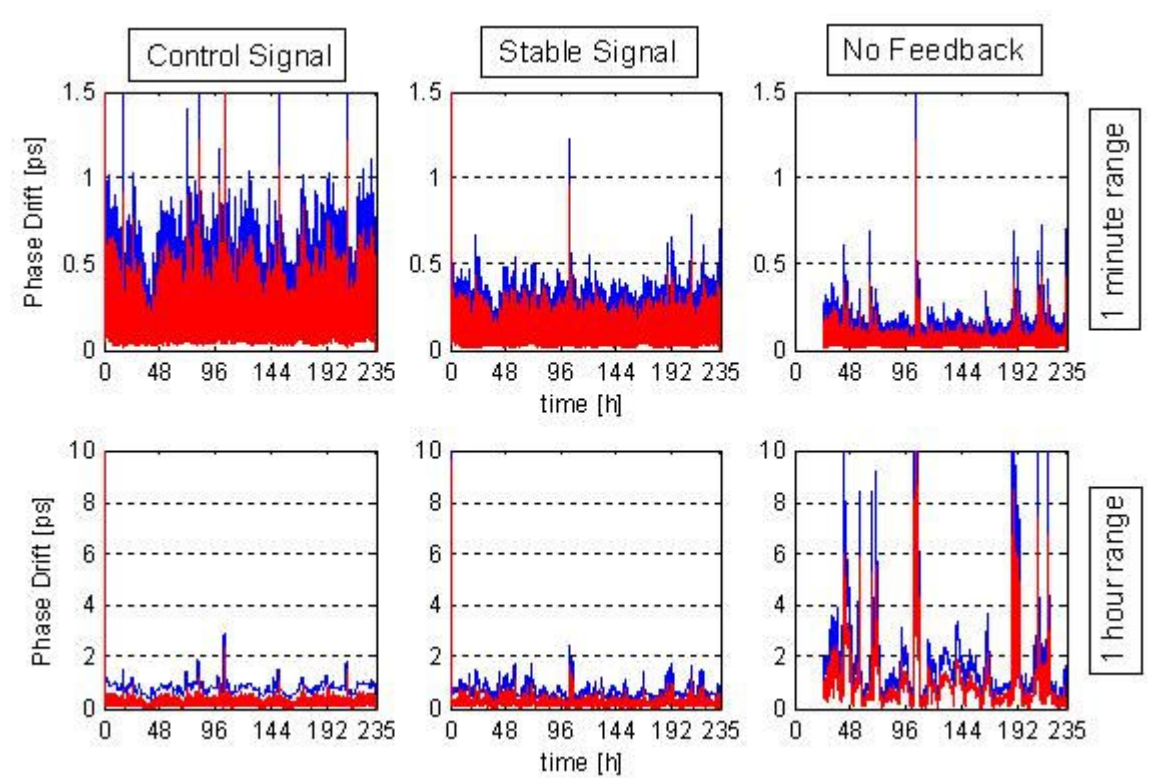


Figure JRA1.9.14: Phase stability results (Red: RMS, Blue: Peak-Peak).

In the near future, a study on phase detector accuracy improvements will be performed. Proper calibration of existing phase detectors will be applied in order to remove errors from the measurement data gathered during the last measurements.

Milestones and deliverables: None defined in the contract for this period.

Significant achievements and impact: Still need to use the old, existing, Master Oscillator.

## JRA1.9.4 Software

### JRA1.9.4.1 Data management development

Progress: In line with schedule.

The database structure has been modified (e.g. new fields such as type of stored value have been added) to allow adding new types later. The user interface to the database was re-designed and improved. The C++ interface has been extended; few bugs (possibly leading to the database inconsistency) were removed. Interfaces for Java and Matlab have been prepared. Batch application (**t\_db\_doocs** – Figure JRA1.9.17) to compare/transfer data between database and DOOCS servers has been developed for external programs and scripts. The GUI front-end (**gtk\_db\_doocs** – Figure JRA1.9.16) to this application has been developed as well. Example data from DOOCS servers (calibration parameters) was transferred to database using GUI application (Figure JRA1.9.16).

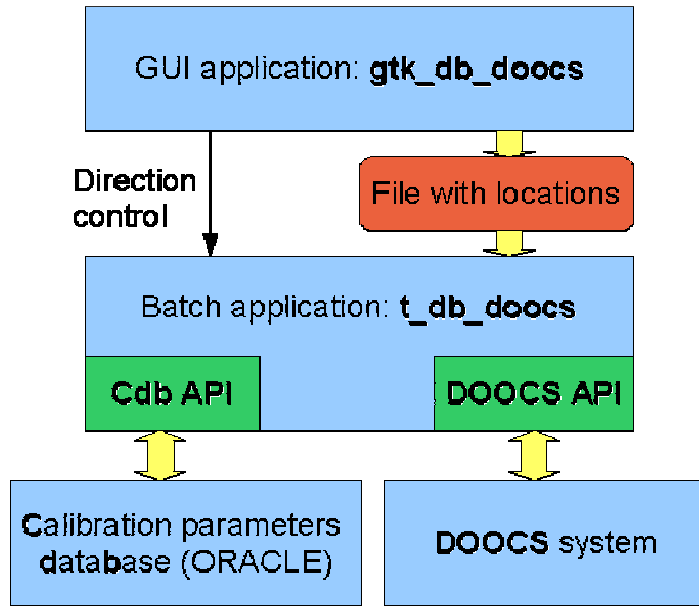


Figure JRA1.9.15: Diagram of data flow between CDB and DOOCS.

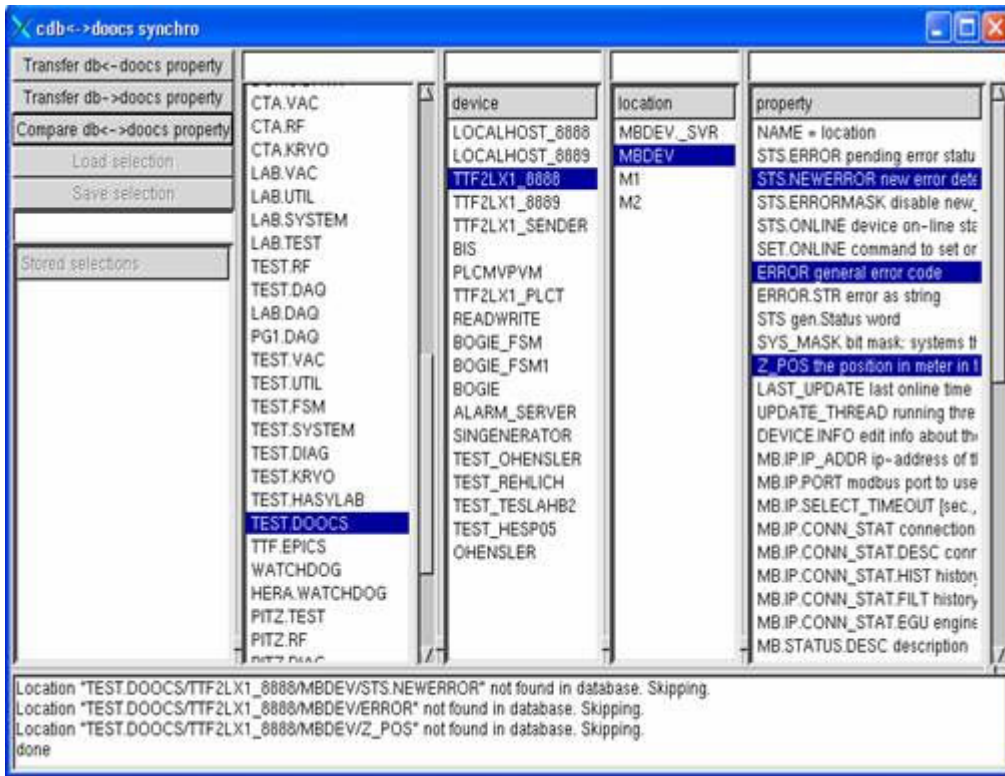


Figure JRA1.9.16: Screenshot from gtk\_db\_doocs application.

```

pc-212-51-219-2.p.lodz.pl - PuTTY
~/gtk_db_doocs$ ./t_db_doocs
Program to compare/transfer data from/to DOOCS properties to/from cdb
Author: Marcin Wójtowski (mwojtow@dmcs.pl)
Syntax: t_db_doocs [-h] [-help] [--help] [-c filename] [-f filename] [-t filename]
-h -help --help prints this help
-c filename compares locations from filename in DOOCS system and cdb
-f filename transfers data from locations specified in filename from cdb to DOOCS
system
-t filename transfers data from locations specified in filename to cdb from DOOCS
system
NOTICE! If filename is either '-' or missing, stdin is used.
~/gtk_db_doocs$

```

Figure JRA1.9.17: Screenshot from batch application.

Milestones and deliverables: Final report.

Significant achievements and impact: the database is ready for tests.

Deviations from plan: small delay (1 month) in the preparation of the final report.

#### JRA1.9.4.2 RF Gun control

Progress:

During LLRF studies in September 2005 the RF Gun was controlled by the SIMCON 3.0 board. New software was written for control of the RF Gun. The RF Gun controller was written in VHDL and implemented in FPGA on SIMCON 3.0. Matlab scripts and DOOCS server were written for communication with the SIMCON 3.0 board. Figure JRA1.9.18 presents the block diagram of VHDL code, inputs and outputs used for RF Gun controller.

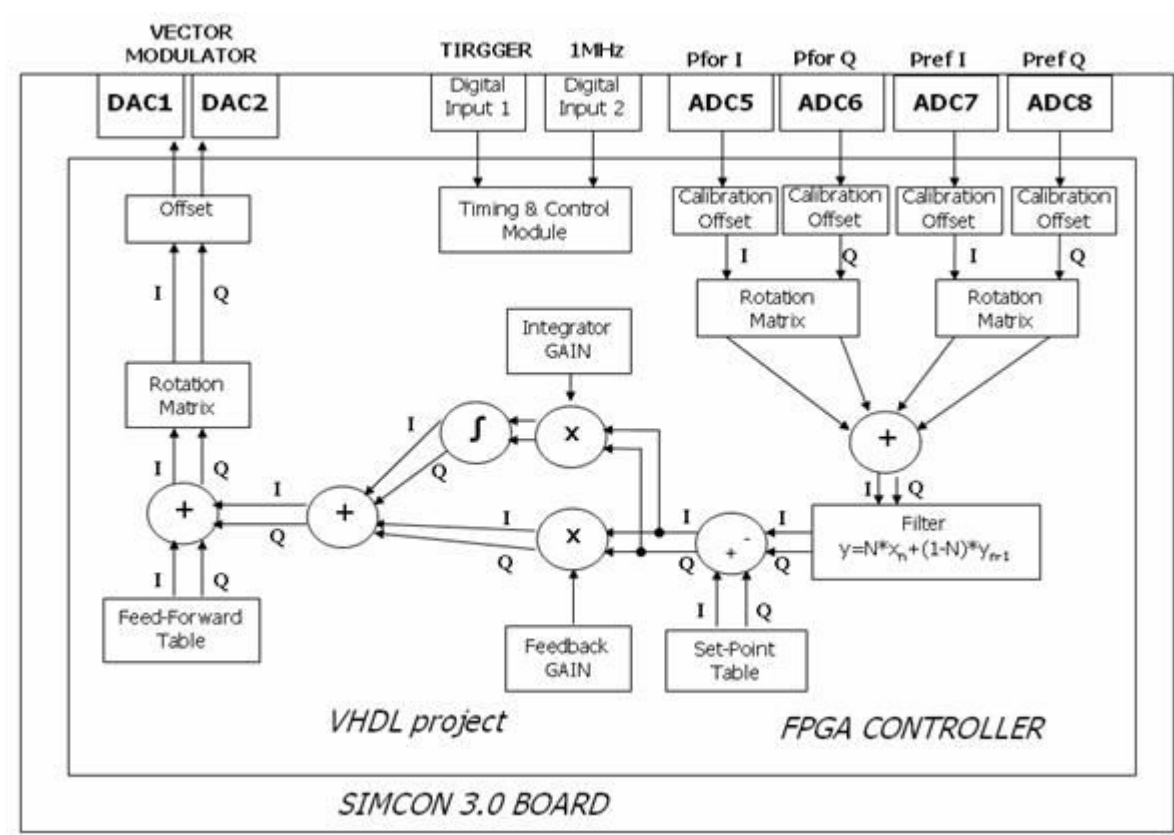


Figure JRA1.9.18: Block diagram of VHDL firmware for RF Gun controller.



This version of the firmware and software was tested with the RF Gun on the VUV-FEL at DESY. All functions of the controller were tested. The controller stabilized the field in the cavity calculated from forward power minus reflected power. For the fast feedback loop PI controller was applied in SIMCON 3.0. After initial tests the stability of the amplitude and phase of the field was as good as with the current control system. The stability of the amplitude during the flat-top was about 1% and phase – 1 deg. The beam was accelerated by the RF Gun. The stability of phase and energy of the beam was measured. The results are presented in Figure JRA1.9.19.

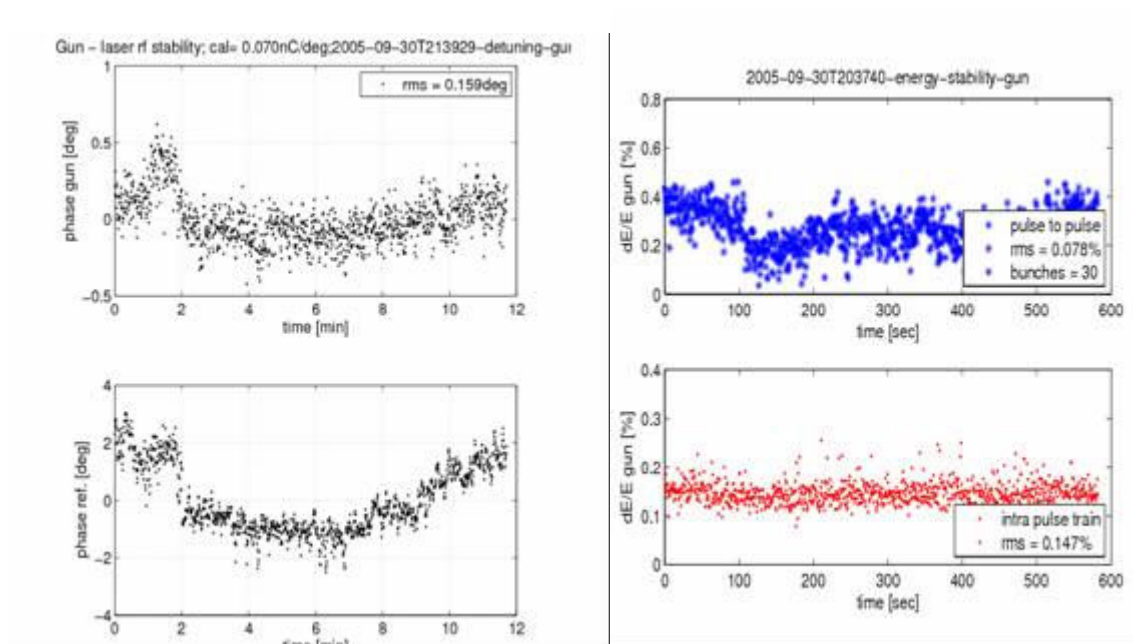


Figure JRA1.9.19: Phase and energy stability of the beam after RF Gun.

Milestones and deliverables: None defined in the contract for this period.

Significant achievements and impact: None.

Deviation from schedule: None.



### JRA1.9.5 Overall Progress of Work Package 9

The following table highlights the progress of work planned in the year 2005 for the Work Package WP9 by listing the lowest level subtasks of the SRF detailed implementation plan.

N°	Task Name	MS, Deliverable	Contractor	% aschlo	2005				2006	
					1.Q05	2.Q05	3.Q05	4.Q05	1.Q06	2.Q06
<b>9</b>	<b>WP9 LOW LEVEL RF (LLRF)</b>			<b>51%</b>						
<b>9.1</b>	<b>Operability and technical performance</b>		<b>DESY</b>	<b>45%</b>						
<b>9.1.1</b>	<b>Transient detector</b>		<b>DESY</b>	<b>36%</b>						
9.1.1.1	Define requirements		DESY	100%						
9.1.1.2	Electronics design		DESY	100%						
9.1.1.3	Build prototype and evaluate		DESY	100%						
9.1.1.4	Final design of detector		DESY	100%						
9.1.1.5	Installation and commissioning		DESY	100%						
9.1.1.6	Test with beam		DESY	0%						
9.1.1.7	<b>Report on transient detector test</b>	<b>Status Report</b>	DESY	0%						
<b>9.1.2</b>	<b>LLRF Automation</b>		<b>TUL/DESY</b>	<b>50%</b>						
9.1.2.1	Dialogue with industrial experts		TUL/DESY	100%						
9.1.2.2	Develop full specification		TUL/DESY	100%						
9.1.2.3	Implement FMS for subsystems		TUL/DESY	100%						
9.1.2.4	Test and evaluation		TUL/DESY	100%						
9.1.2.5	Implement improvements		TUL/DESY	70%						
9.1.2.6	Evaluation and acceptance by operators		TUL/DESY	0%						
9.1.2.7	<b>Report on LLRF atomization design</b>	<b>Status Report</b>	TUL/DESY	0%						
<b>9.1.3</b>	<b>Control optimization</b>		<b>WUT-ISE/DESY</b>	<b>35%</b>						
9.1.3.1	Specification of system		WUT-ISE/DESY	100%						
9.1.3.2	Conceptual design of controller		WUT-ISE/DESY	100%						
9.1.3.3	Performance simulation		WUT-ISE/DESY	100%						
9.1.3.4	Implementation in DSP hardware		WUT-ISE/DESY	80%						
9.1.3.5	Implementation and tests on TTF		WUT-ISE/DESY	0%						
9.1.3.6	<b>Evaluation of test results</b>	<b>Status report</b>	WUT-ISE/DESY	0%						
<b>9.1.4</b>	<b>Exceptional handling routines</b>		<b>DESY</b>	<b>67%</b>						
9.1.4.1	Specification		DESY	100%						
9.1.4.2	Design of exceptional handler		DESY	100%						
9.1.4.3	Implementation and test on TTF		DESY	60%						
9.1.4.4	<b>Report on exceptional handler operation</b>	<b>Status Report</b>	DESY	0%						02.12.
<b>9.2</b>	<b>LLRF cost and reliability study</b>		<b>TUL</b>	<b>44%</b>						
<b>9.2.1</b>	<b>Cost and reliability study</b>		<b>TUL</b>	<b>47%</b>						
9.2.1.1	Identify cost drivers of present LLRF		TUL	100%						
9.2.1.2	Develop cost reduction ideas		TUL	100%						
9.2.1.3	Build prototypes and evaluate		TUL	100%						
9.2.1.4	Final design of LLRF system		TUL	15%						
9.2.1.5	<b>Complete design of LLRF system for reduced cost</b>	<b>Status Report</b>	TUL	0%						
<b>9.2.2</b>	<b>Radiation damage study</b>		<b>TUL</b>	<b>42%</b>						
9.2.2.1	Identify critical electronics issues		TUL	100%						
9.2.2.2	Evaluate TESLA radiation		TUL	100%						
9.2.2.3	Develop tests for components		TUL	100%						
9.2.2.4	Procure and assemble test set up		TUL	100%						
9.2.2.5	Data acquisition from radiation tests		TUL	100%						
9.2.2.6	Analyze results and develop countermeasures		TUL	80%						
9.2.2.7	Implement countermeasures and verify		TUL	10%						
9.2.2.8	<b>Report on radiation damage studies</b>	<b>Status Report</b>	TUL	0%						
<b>9.3</b>	<b>Hardware</b>		<b>WUT-ISE</b>	<b>70%</b>						
<b>9.3.1</b>	<b>Multichannel downconverter</b>		<b>WUT-ISE</b>	<b>100%</b>						
9.3.1.1	Study and compare technologies		WUT-ISE	100%						
9.3.1.2	Select optimum PCB design		WUT-ISE	100%						
9.3.1.3	Build prototype and evaluate		WUT-ISE	100%						
9.3.1.4	Finalize multichannel downconverter		WUT-ISE	100%						
9.3.1.5	Determine characteristics		WUT-ISE	100%						
<b>9.3.2</b>	<b>Third generation RF control</b>		<b>WUT-ISE</b>	<b>80%</b>						
9.3.2.1	Integrate system generator with VHDL		WUT-ISE	100%						
9.3.2.2	Complete specification		WUT-ISE	100%						
9.3.2.3	Demonstrate simulator		WUT-ISE	100%						
9.3.2.4	Final design of RF electronic board		WUT-ISE	90%						
9.3.2.5	Evaluate performance		WUT-ISE	20%						
<b>9.3.3</b>	<b>Stable frequency distribution</b>		<b>WUT-ISE</b>	<b>50%</b>						
9.3.3.1	Complete specification		WUT-ISE	100%						
9.3.3.2	Conceptual design of frequency		WUT-ISE	100%						
9.3.3.3	Build prototype and evaluate		WUT-ISE	100%						
9.3.3.4	Final design		WUT-ISE	100%						
9.3.3.5	Procurement and assembly of subsystems		WUT-ISE	100%						
9.3.3.6	Installation and commissioning		WUT-ISE	30%						
9.3.3.7	Performance test with beam		WUT-ISE	0%						
9.3.3.8	<b>Report on new LLRF hardware components</b>	<b>Final Report</b>	WUT-ISE	0%						01.03.

## A. ACTIVITY REPORT

N°	Task Name	MS, Deliverable	Contractor	%	2005				2006	
					1.Q05	2.Q05	3.Q05	4.Q05	1.Q06	2.Q06
<b>9.4</b>	<b>Software</b>		<b>TUL/WUT-ISE</b>	<b>54%</b>						
<b>9.4.1</b>	<b>Data management development</b>		<b>TUL/WUT-ISE</b>	<b>67%</b>						
9.4.1.1	Specification		TUL/WUT-ISE	100%						
9.4.1.2	Conceptual design with DOOCS		TUL/WUT-ISE	100%						
9.4.1.3	Prototype		TUL/WUT-ISE	100%						
9.4.1.4	User evaluation		TUL/WUT-ISE	100%						
9.4.1.5	Finalize design		TUL/WUT-ISE	100%						
9.4.1.6	Implementation in TTF		TUL/WUT-ISE	20%						
9.4.1.7	<b>Report on data management developments</b>	<b>Final Report</b>	<b>TUL/WUT-ISE</b>	<b>0%</b>						
<b>9.4.2</b>	<b>RF gun control</b>		<b>PSI/WUT-ISE</b>	<b>47%</b>						
9.4.2.1	Write specification		PSI/WUT-ISE	100%						
9.4.2.2	Design of controller		PSI/WUT-ISE	100%						
9.4.2.3	Procurement and assembly		PSI/WUT-ISE	100%						
9.4.2.4	Installation and test		PSI/WUT-ISE	30%						
9.4.2.5	<b>Report on RF gun control tests</b>	<b>Final Report</b>	<b>PSI/WUT-ISE</b>	<b>0%</b>						

## JRA1.10 Work Package 10: Integrated RF tests in a Horizontal Cryostat

### JRA1.10.1 Activity Status

Before starting the different tests planned in the CARE proposal (cold tuning system, piezo and magnetostrictive fast tuners, new couplers) it was necessary to first qualify a standard “nine cell cavity” equipped with a high power TTF-III coupler in CryHoLab.

The first part of this qualifying test was to check possible cryogenic problems (helium tank filling, coupler cool down, temperature measurements and helium bath pumping...). During the cool down at 1.8K, in January 2005, no specific problem appeared, except the very long thermalisation time of the whole structure: consequently, we improved the thermal connections between the cavity support and the He gas pipe.

The second part of this test was to check the possible problems linked to the cavity working at high RF power. Some problems appeared on the water cooling system and klystron modulator (which was being used beyond its rated values) involving the complete changing of the insulating-oil (4500 liters). As a consequence, the “high power pulsed test” was performed with some delay in July.

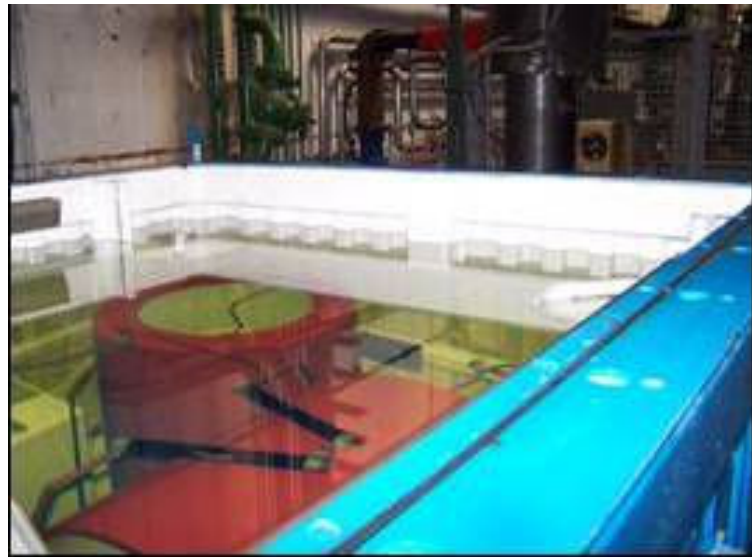


Figure JRA1.10.1: The klystron-modulator components are transferred, after cleaning, in the oil-tank refilled with 4300 liters of new oil.

After the RF coupler conditioning (300 K, 1 MW, 1 ms, 3.8 Hz), the pulsed RF power was injected in the 9-cell cavity following cool down to 4K. We can see on figure JRA1.10.2 the reflected power and the transmitted power signals from pick-up probes. In pulsed RF mode (4 K, 900 kW, 250  $\mu$ s, 0.8 Hz), the maximum accelerating field reached 18 MV/m with

a power limitation due to a strong field emission with X-rays detected ( $7 \mu\text{V/h}$  around the cryostat ).

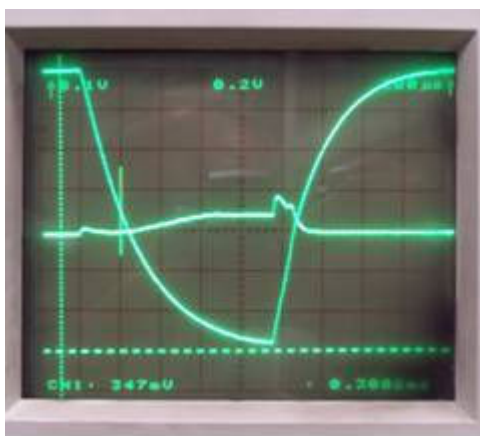


Figure JRA1.10.2: Oscilloscope traces of transmitted (upper) and reflected power (lower).

After these qualifying tests, the “CEA Cold Tuning System” was assembled on a nine cell cavity at the beginning of September 2005. Preliminary measurements of “microphonic” resonances were performed at room temperature in the RF laboratory (see WP8) and in CryHoLab (see Fig.JRA1.10.3). At the present time, RF tests are under way at 4 K.

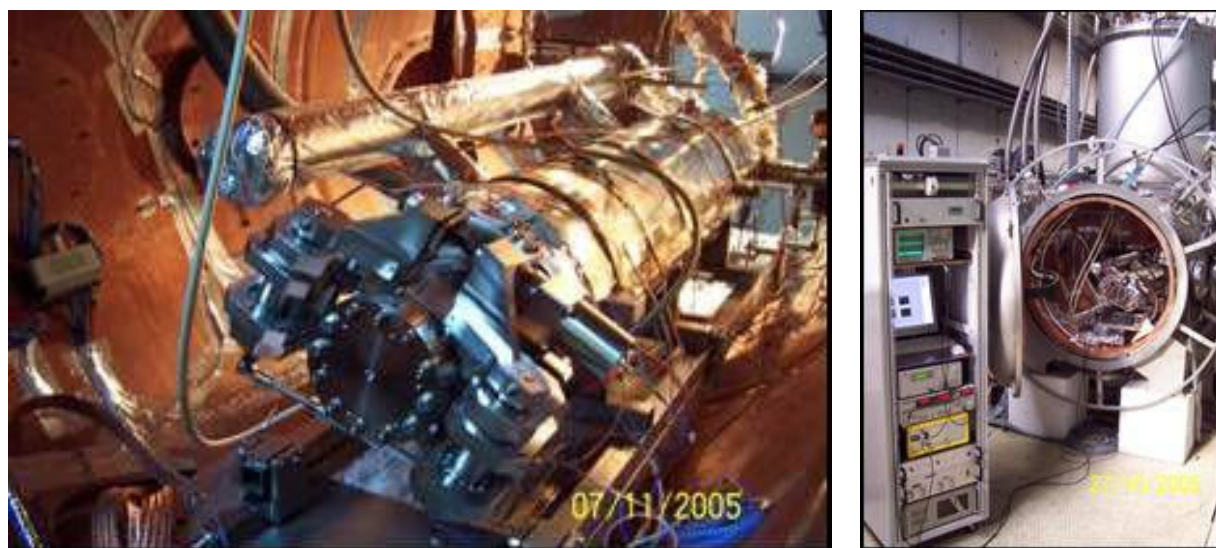
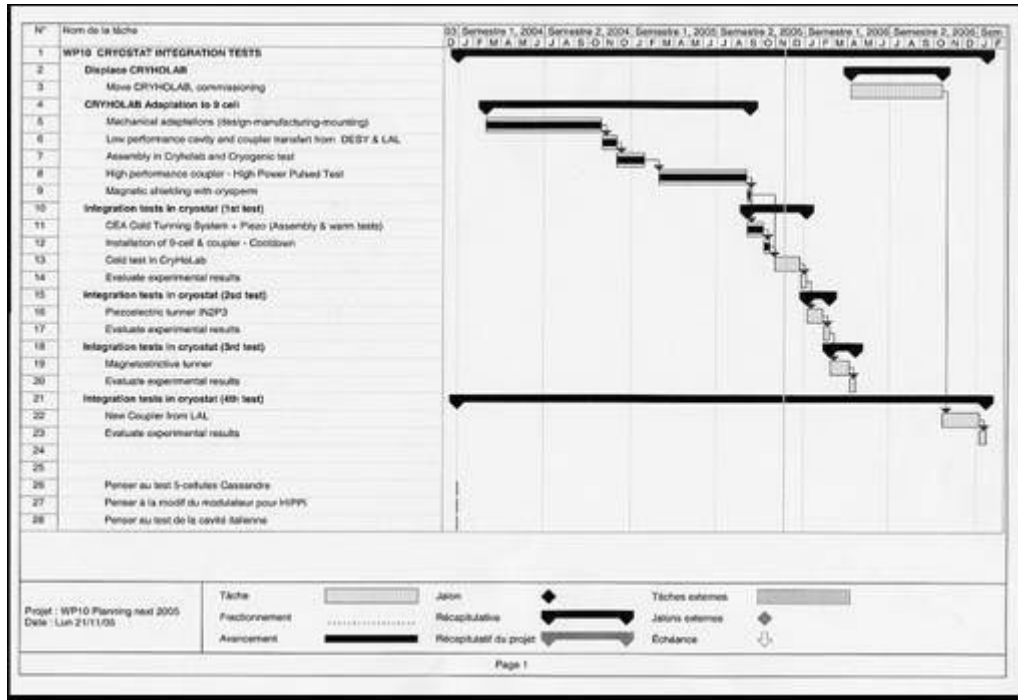


Figure JRA1.10.3: Cold Tuning System (CTS) with Noliac Piezo Tuner mounted on 9-cell cavity for cold test in CryHoLab.

The removal of CryHoLab from “l’Orme des Merisiers” area to the main Saclay Center is delayed once again. The transfer should take place in April 2006, after CTS tests with piezo and magnetostrictive tuners.



### JRA1.10.2 Overall Progress of Work Package 10

The following table highlights the progress of work planned in the year 2005 for the Work Package WP10 by listing the lowest level subtasks of the SRF detailed implementation plan.

N°	Task Name	MS, Deliverable	Contractor	% aschlo	2005				2006	
					1.Q05	2.Q05	3.Q05	4.Q05	1.Q06	2.Q06
<b>10</b>	<b>WP10 CRYOSTAT INTEGRATION TESTS</b>			<b>45%</b>						
10.1	Displace CRYHOLAB		CEA	0%						
<b>10.2</b>	<b>CRYHOLAB adaption to 9 cell</b>		CEA	<b>90%</b>						
10.2.1	Mechanical adaption		CEA	100%						
10.2.2	Low performance cavity and coupler		CEA	100%						
10.2.3	Assemlly in CRYHOLAB and cryogenic test		CEA	100%						
10.2.4	High performance coupler - High power pulsed test		CEA	75%						
10.2.5	Magnetic shielding with cryoperm		CEA	0%						
<b>10.3</b>	<b>Integration tests in cryostat (1st test)</b>		CEA	<b>0%</b>						
10.3.1	CEA Cold Tuning System + Pezo (Assembly + warm test)		CEA	0%						
10.3.2	Installation of 9-cell & coupler - Cooldown		CEA	0%						
10.3.3	Cold test in CryHoLab		CEA	0%						
10.3.4	Evaluate experimental results	Status repor	CEA	0%						
<b>10.4</b>	<b>Integration tests in cryostat (2nd test)</b>		CEA	<b>0%</b>						
10.4.1	Magnetostrictive tuner		CEA	0%						
10.4.2	Evaluate experimental results	Status repor	CEA	0%						
<b>10.5</b>	<b>Integration tests in cryostat (3rd test)</b>		CEA	<b>0%</b>						
10.5.1	Piezoelectric tuner		CEA	0%						
10.5.2	Evaluate experimental results	Status repor	CEA	0%						
<b>10.6</b>	<b>Integration tests in cryostat (4th test)</b>		CEA	<b>0%</b>						
10.6.1	New coupler from LAL		CEA	0%						
10.6.2	Evaluation of results		CEA	0%						
10.6.3	Final evaluation	Final Report	CEA	0%						

### JRA1.11 Work Package 11: Beam Diagnostics

#### JRA1.11.1: Beam Position Monitor (CEA)

##### Activity status

The activity of this year has been to design a new version of the monitor (new mechanical and RF characteristics) to have a good resolution (around 1 μm) and a high time resolution (around 10 ns). Another part of the activity has been to start testing the monitor (BPM) inside the ACC1 cryostat with the beam to observe its performance. As of September 2005, in agreement with the CARE Steering Committee, the research activity on the possible use of the dipolar Higher Order Modes (HOM) of the accelerating superconducting cavities to monitor the beam position along the TTF2 linac has been included in the Work Package 11.

### JRA1.11.1.1: Development of the re-entrant RF BPM.

#### New design of the BPM cavity

The mechanical structure shown in Fig.JRA1.11.1 has an overall length of 170 mm and is quite similar to the BPM in ACC1 on TTF2. The gasket is a conflat gasket.

The position and the design of feed-throughs changed (Fig.JRA1.11.2). Indeed, a critical point was the feed-through fragility, 50% of the feed-throughs had to be rejected. With the new design, the feed-throughs are simpler and more robust. Moreover, this new design has no resonant mode. To have a higher Q and therefore a longer signal in time, the feed-throughs moved from 31.5 mm in the re-entrant part. With this movement, the monopole and dipole signals are more clearly distinguished and the rejection of the monopole signal is better.

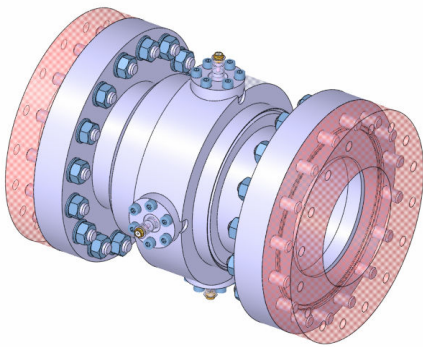


Figure JRA1.11.1: Design of the new cavity BPM

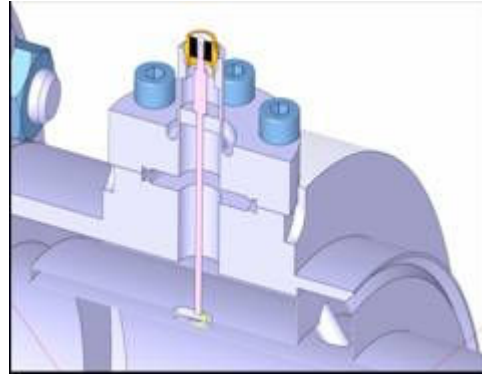


Figure JRA1.11.2: Design of the new feed-through

One of the biggest problems on the cavity in ACC1 was the cleaning. As the BPM is designed to be used in a clean environment and at cryogenic temperatures, twelve holes of 5 mm diameter were drilled at the end of the re-entrant part. A simulation was carried out to check that the RF characteristics of the re-entrant cavity do not change. Cleaning tests were successfully performed at DESY and validated the system for the cleaning.

The simulation of the new design leads to the RF characteristics given in Table 11.1.

	New BPM			
	F (GHz)	Q	R/Q at 5mm of the center of cavity	R/Q at 10mm of the center of cavity
Monopole Mode	1.25	24	13 $\Omega$	13 $\Omega$
Dipole Mode	1.72	51.4	0.25 $\Omega$	1.11 $\Omega$

Table 11.1: RF characteristics of new BPM calculated with HFSS

The choice of resonant mode frequencies was determined according to the 180° junction hybrid available on the market. The resolution of around 1  $\mu\text{m}$ , but also the mechanical feasibility of the structure, determined the quality factors, Q, of the monopole and dipole modes. They should be neither too high to keep a time resolution around 10 ns nor too low in order to have a centring accuracy better than 1  $\mu\text{m}$ .

#### Development of a new hybrid coupler

The new hybrid coupler is the Anaren model 3A0055. It's a 180° hybrid coupler and its isolation is more than 25 dB in the band 1-2 GHz. It can be optimized at the frequency of the dipole mode with attenuators and phase shifters to have an isolation around 50 dB.

#### Signal processing of the new BPM

The signal processing of the new re-entrant BPM is composed of a 180° hybrid junction, which is connected to each pair of opposite antennae with 33 m of semi-rigid cables. The



rejection of the monopole mode proceeds in three steps. One is made by the new hybrid coupler, the second with the pass band filter, which rejects the monopole mode on the delta channel and the third with the synchronous detection. The noise is limited by the bandpass filters. The one on the  $\Delta$  channel has to have the centre frequency of the dipole mode and the one on the  $\Sigma$  channel the centre frequency of the monopole mode. To perform the synchronous detection, the signals must be amplified. The 9 MHz reference signal, from the control system on TTF2, combined with some PLLs generates signals at the monopole and dipole mode frequencies. These are used as local oscillators for the mixers. Some phase shifters, controlled by the digital electronics, adjust the PLL signals, which have to be in phase with the signals coming from the hybrid. The digital electronics also allows the sampling, the calibration of the system and the controls interface. The signal on the  $\Sigma$  channel is used in order to normalize the  $\Delta$  signal, which determines the position of the beam. This normalization is, also, made by digital electronics. The schematic of the new electronics is shown figure JRA1.11.3.

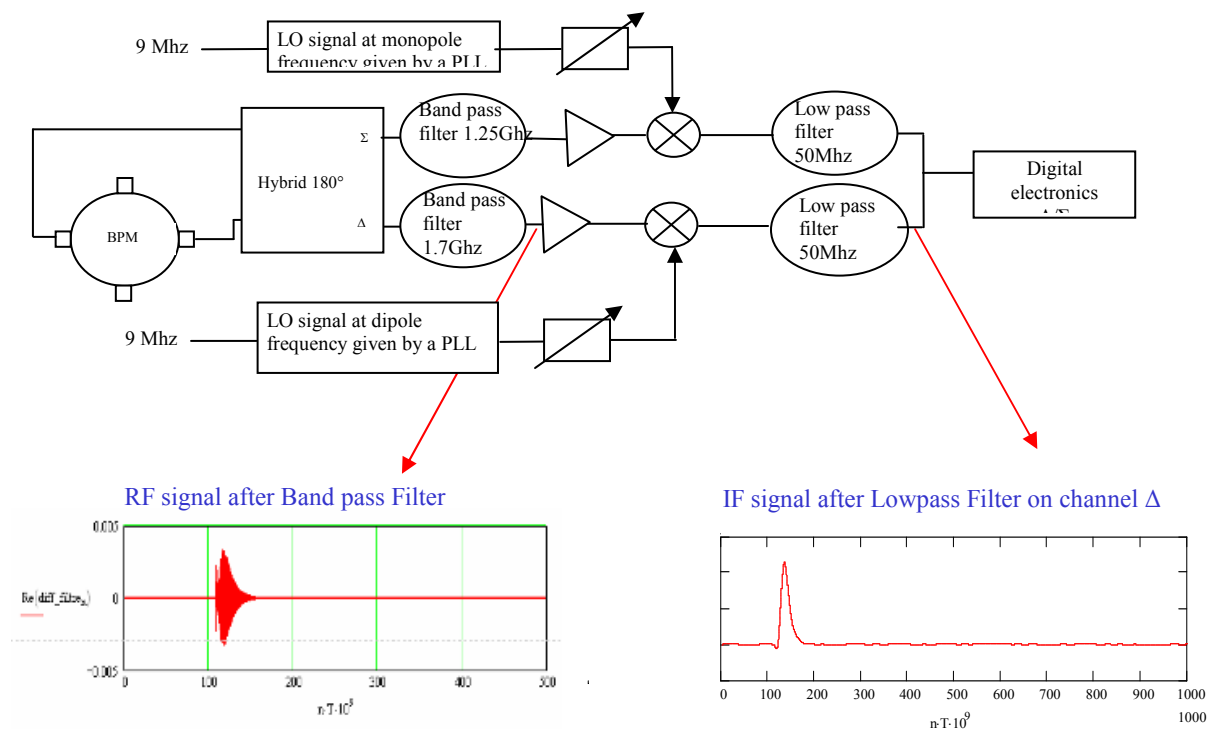


Figure JRA1.11.3: Electronics of the new system.

### Beam tests of BPM in ACC1

The RF calibration is done:

- A high isolation between the sum and delta channels is achieved: x channel 46 dB, y channel 57 dB.
- The synchronous detection works and the phase tuning is done to provide 'good' sensitivity. The LO signals were adjusted with some phase shifters to have the maximum of the dipole signal.
- The simultaneous sampling has to be done at the peak of the sum signal, which does not correspond to the maximum peak of the delta signals.

The calibration with the beam is also done<sup>1</sup>:

- The BPM charge (BPM9ACC1) is calibrated by correlating with the signal from a toroid (3GUN) (see Fig.JRA1.11.4 and Fig.JRA1.11.5).

<sup>1</sup> We thank N. Baboi from DESY who made all these measurements



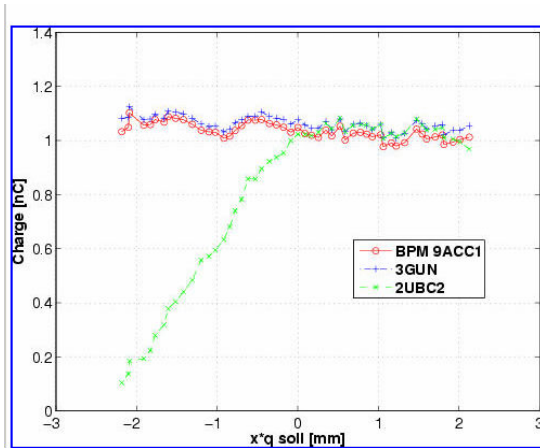


Figure JRA1.11.4 : Charge vs. beam position

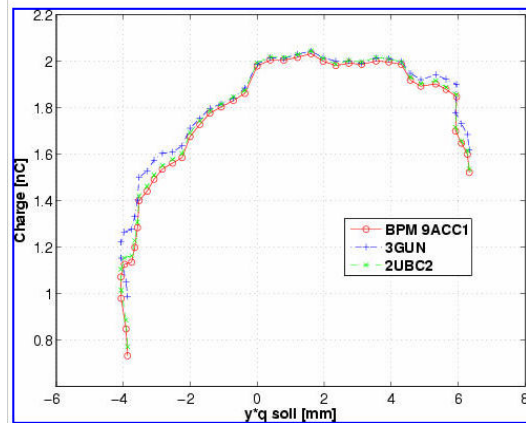


Figure JRA1.11.5 : Charge vs beam

Figures JRA1.11.6 and JRA1.11.7 show the beam position read by the BPM vs the beam position that we should have. The range of the BPM linearity is 4 mm then there is saturation. It may be caused by electronics and in particular saturation of some amplifiers.

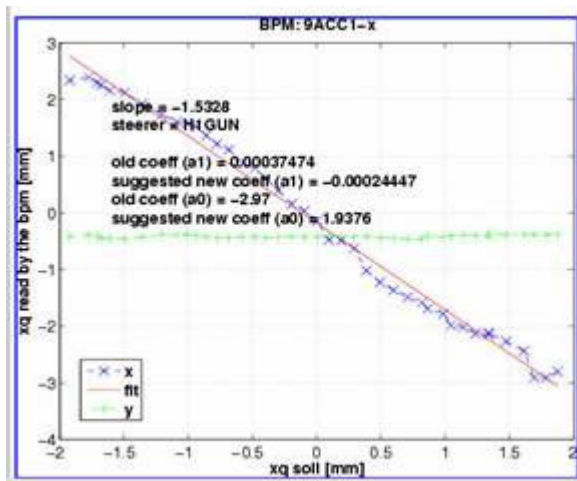


Figure JRA1.11.6: Beam position read by the BPM vs expected beam position (horizontal).

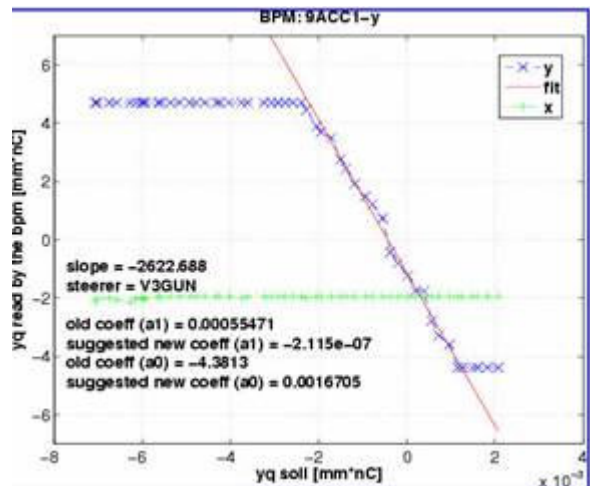


Figure JRA1.11.7: Beam position read by the BPM vs expected beam position (vertical).

More beam tests have to be done on this BPM, which is in ACC1, to understand its saturation and to know its resolution.

### Schedule of the re-entrant BPM

The status and planning for the re-entrant BPM are as follows:

- Design and mechanical drawings of the BPM cavity are ready.
- Design of the RF electronics and signal processing are made.
- Signal processing board will be fabricated for March 2006.
- A BPM cavity will be fabricated for the beginning of 2006.
- Tests on the electronics will be made at the beginning of 2006.
- Preliminary tests on this new BPM to verify RF characteristics of the cavity and validate the fabrication process: brazing, heat treatment, cleaning and dust free mounting, will be done during the spring of 2006.

### JRA1.11.1.2: The HOM-BPM program

#### Activity historical background

The possibility of using the lowest frequency dipole modes of the accelerating SC cavities in order to measure the beam transverse position has been studied at TTF since 2002 by a CEA-DESY collaboration. In October 2003, the PhD thesis of R. Paparella on the subject was co-

funded by these two institutes. The first evidence for 50  $\mu\text{m}$  beam centering accuracy and position resolution (10 times smaller than the cavity alignment in the cryomodules) was obtained in June 2004 with four dipole modes on the first two ACC1 cavities (see Fig 11.8). This result was published at the LINAC'04 conference. In the fall 2004, the SLAC instrumentation group joined the collaboration with the aim of building dedicated acquisition electronics and to equip all the HOM couplers of the 40 TTF linac cavities. In June 2005, such prototype electronics was used to show that a 5  $\mu\text{m}$  BPM resolution was within reach. This result was published at the PAC'05 conference.

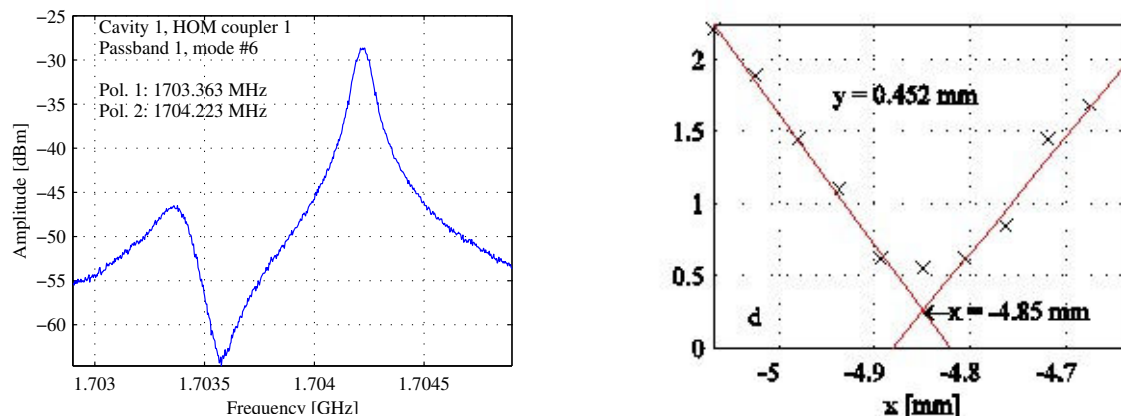


Figure JRA1.11.8: Beam excitation of a pair of dipole HOM polarisations in ACC1 first cavity (left), and beam steering through the electric centre of this mode (right).

In September 2005 the CARE steering committee approved the CEA proposal to include the HOM-BPM activity within the BPM task of the beam instrumentation work package. Since the material cost and the manpower dedicated to this activity is entirely provided by CEA, DESY and SLAC internal resources, the CARE/SRF support aims to help and re-inforce the collaborative work with travel funds used by CEA personnel.

### Objectives, deliverable and milestone within CARE-JRA1

The main objectives of the HOM-BPM collaboration are:

1. to prove (or disprove) the potential of the HOM-BPM instrumentation to monitor the beam orbit through the TTF2 linac cryomodules in order to minimize the bunch emittance growth;
2. to measure the cavity centres and relative misalignments within the five TTF cryomodules.

Given the relatively modest support requested from JRA1, it is suggested that the corresponding deliverable is a report evaluating the HOM-BPM experimental operation with respect to these two objectives. This deliverable should be added to the CARE-JRA1-WP11 deliverables, with a delivery date at the end of 2006 (month 36).

On the way to these objectives, the most important milestone of the activity is the commissioning of the complete SLAC-built 80-channel HOM electronics (see Fig. 11.9). This commissioning is planned during the TTF2 beam time period dedicated to the linear collider developments in the spring 2006. This milestone should thus occur by mid-2006 (month 30).

### Activity in 2005

By October 2005, Claire Simon, from CEA, visited SLAC for one month to collaborate in the test program of the complete set of 40 HOM electronics boards. With the test program successfully finished, the complete HOM electronics have been shipped to DESY and installed on the TTF linac in November 2005. Beam induced HOM signals have been recorded and will be analyzed in the beginning of 2006.

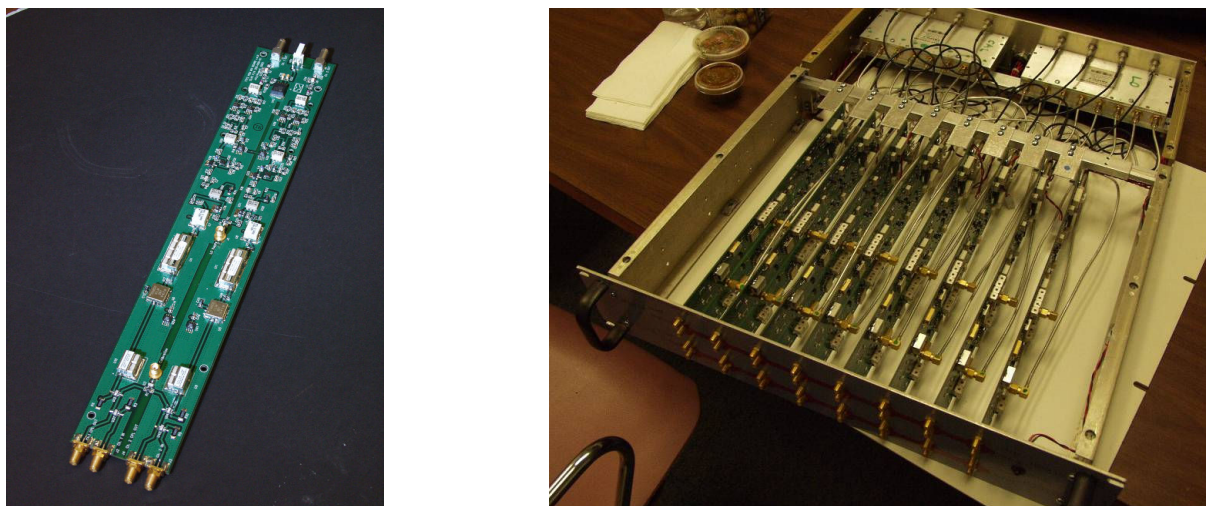


Figure JRA1.11.9: HOM electronics board for one cavity (left) and HOM electronics drawer for one TTF module of eight cavities (right), designed, built and tested at SLAC.

### JRA1.11.2: Beam Emittance Monitor (INFN-LNF and INFN-Ro2)

In the past year all the hardware of the experiment has been constructed and installed on the accelerator, and the integration of the dedicated software for image acquisition and analysis in the general control system of TTF is completed, fulfilling the milestone of being ready for data taking.

The target was built using a lithography technique starting from a silicon nitride wafer and opening the slits by means of chemical etching. The surface roughness, the planarity of the target mounted in the holder, and the sharpness of the apertures borders were carefully measured.



Figure JRA1.11.10: The DR screen with two slits of 0.5 and 1 mm respectively.

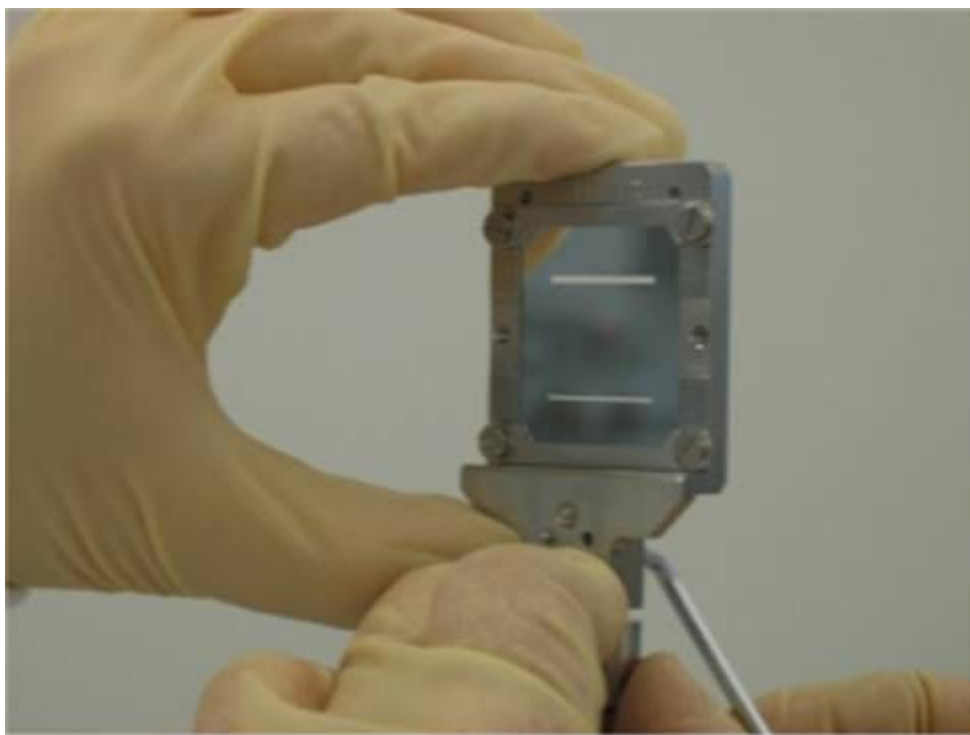


Figure JRA1.11.11: The DR screen mounted on the vacuum linear actuator.

A modified version of the optical system has been installed, allowing both the standard beam imaging and imaging of the radiation angular distribution. Two interferential filters and a polarizer are also present and can be remotely inserted in the radiation path.

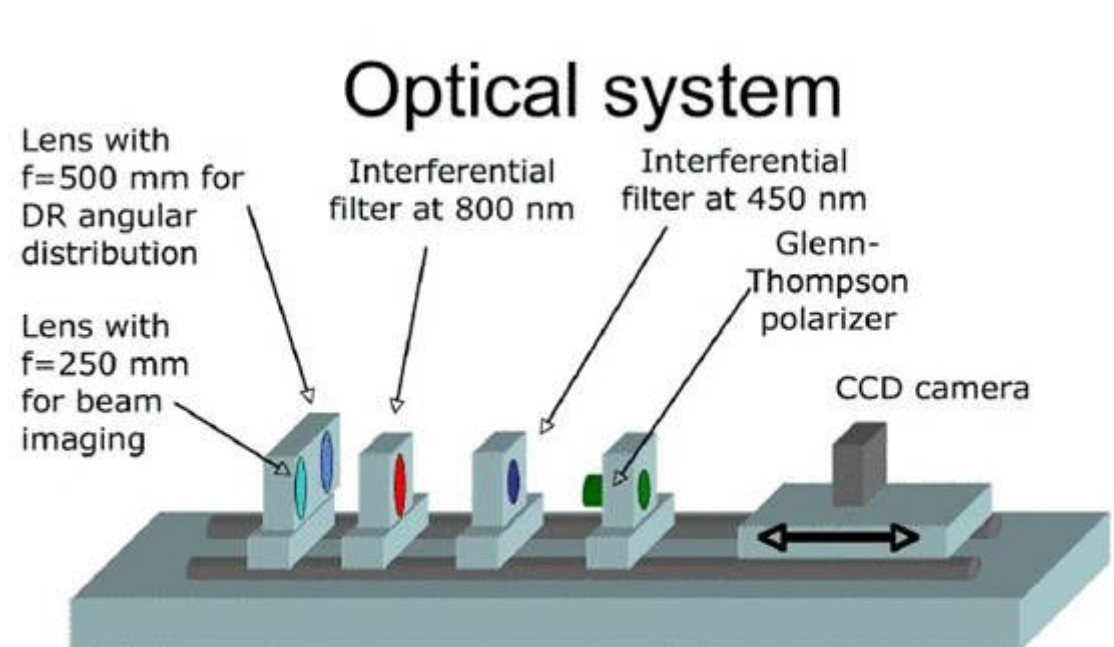


Figure JRA1.11.12: Sketch of the optical system.



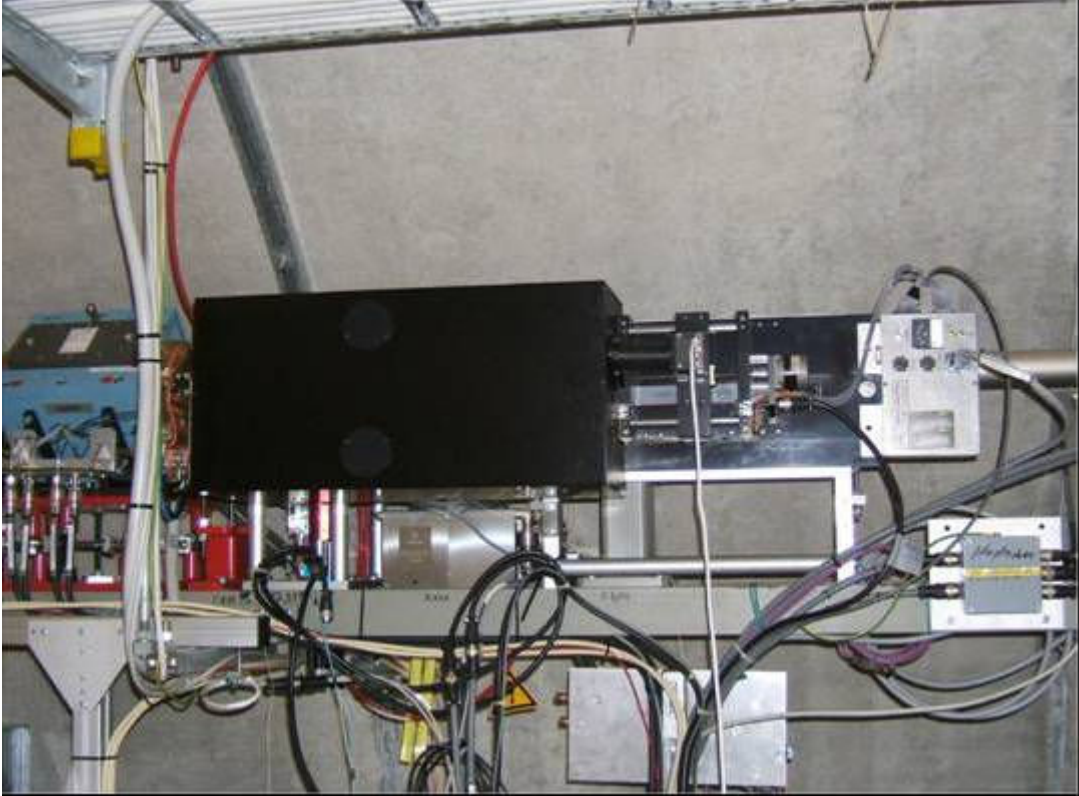
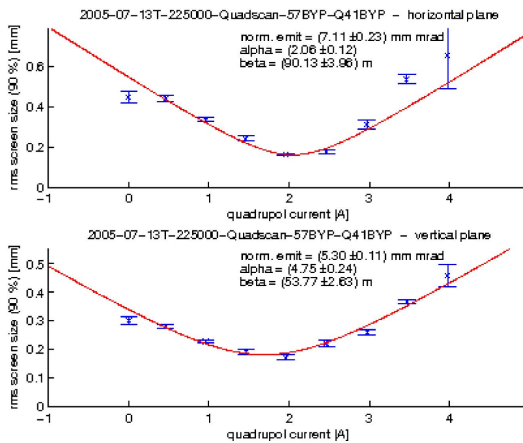


Figure JRA1.11.13: Complete optical system installed on the vacuum pipe of the by-pass line. The transport optics in the by-pass has been verified for the possibility of having a waist of suitable dimension at the diffraction radiation screen position.



Horizontal and vertical beam sizes were fitted @ 445 MeV

$$\epsilon_{nx} = (7.11 \pm 0.23) \cdot 10^{-6} \text{ m rad}$$

$$\epsilon_{ny} = (5.30 \pm 0.11) \cdot 10^{-6} \text{ m rad}$$

Figure JRA1.11.14: Quadrupole scan at the DR screen location.

We are now ready for data taking, satisfying the milestone fixed for December 31st 2005. Adequate beam time has been requested on the TTF Facility.

### JRA1.11.3 Overall Progress of Work Package 11

The following table highlights the progress of work planned in the year 2005 for the Work Package WP11 by listing the lowest level subtasks of the SRF detailed implementation plan.

N°	Task Name	MS, Deliverable	Contractor	% aschlo	2005				2006	
					1.Q05	2.Q05	3.Q05	4.Q05	1.Q06	2.Q06
<b>11</b>	<b>WP 11 BEAM DIAGNOSTICS</b>			<b>49%</b>						
<b>11.1</b>	<b>Beam position monitor</b>			<b>46%</b>						
11.1.1	Present BPM installed in TTF module	Start Measurement		100%						
11.1.2	Cryogenic measurements on BPM			100%						
11.1.3	Beam tests of BPM on TTF			60%						
11.1.4	Design of BPM Cavity			100%						
11.1.5	Design of BPM cavity ready			100%						
11.1.6	Fabrication of BPM Cavity			0%						
11.1.7	BMP cavity ready			0%						
11.1.8	Development of new hybrid coupler and electronics			100%						
11.1.9	Design of Digital Signal Processing			80%						
11.1.10	New BPM ready for installation	BPM Prototype		0%						
11.1.11	Beam Tests with new BPM			0%						
11.1.12	Evaluation of BPM operation	Final Report		0%						
<b>11.2</b>	<b>Beam Emittance Monitor</b>			<b>54%</b>						
11.2.1	Slit width simulations			100%						
11.2.2	Slit design			100%						
11.2.3	Optics simulations			100%						
11.2.4	Optics appropriations			100%						
11.2.5	System assembly and tests			100%						
11.2.6	Mechanical assembly at TTF			100%						
11.2.7	Optical assembly at TTF			100%						
11.2.8	Integration of controls into TTF			100%						
11.2.9	Ready for beam test in TTF	Start Measurement		100%						
11.2.10	Beam tests at TTF			0%						
11.2.11	Evaluate first beam test result	Status Report		0%						
11.2.12	Successive measurements			0%						
11.2.13	Final evaluation	Final Report		0%						

### JRA1.12 Significant Achievements

Significant progress has been made in all work-packages of SRF during 2005. The following points are noteworthy:

- The construction of a spinning machine for seamless cavity production (WP3) is now complete.
- Improved understanding of the “ageing” of electro-polishing mixtures (WP5) will probably lead to improvements in this important cavity preparation technique. An automated electro-polishing system is now operating at DESY.
- New active tuners (WP8) have been developed at CEA and INFN, using piezo-electric cells, which will be ready for tests with cavities early in 2006. The application of a piezo-electric tuner has been demonstrated to reduce Lorentz force de-tuning from 180 Hz to less than 10 Hz on a TTF cavity operating at 20 MV/m.
- Several advances have been made in Low Level RF development (WP9) where, to give but one example, optimal controlling routines have been developed to provide RF phase stability of 0.03 degrees and amplitude stability of  $3 \times 10^{-4}$  on a TTF-VUV module.
- Both the hardware and software for the beam emittance monitor of WP11 are now complete ahead of schedule. The monitor has been mounted on the TTF beam-line and is awaiting allocation of beam time for the first tests.



**JRA1.13 List of all milestones and deliverables (D) during the reporting period**

No.	Task	Milestones and Deliverables	Title	planned end	expected end	Reference	contractor
1	2.1.7	<b>Final Report (D)</b>	<b>Final report on reliability issue</b>	<b>31.12.05</b>	31.12.05	under preparation	DESY
2	2.2.1.9	Design Report	Report about new design for components	16.09.05	01.11.05	Report Sept. 16, 2005	INFN-Mi
3	2.3.2.6	Tools Ready	Tools fabrication finished	11.03.05	01.10.05	Quarter Report 2-05	DESY
4	2.3.3.3	Commissioning	Start production welding of components	11.03.05	01.05.05	Quarter Report 1-05	DESY
5	3.1.2.5	Commissioning	Spinning machine ready	10.11.05	15.08.05	Quarter Report 2-05	INFN-LNL
6	3.2.2.5	Commissioning	Hydro forming machine ready	01.07.05	01.06.05	Quarter Report 2-05	DESY
7	3.2.3.5	Design report	Construction tube necking machine finished	24.02.05	31.19.05	SRF Annual Meeting 05'	DESY
8	3.2.4.3	Design report	Seamless tubes ready	01.07.05	15.07.05	Quarter Report 2-05	DESY
9	4.1.1.6	Apparatus ready	Coating apparatus operational	14.03.05	31.07.05	Quarter Report 2-05	IPJ
10	4.1.1.7.3	Hardware ready	Droplet filter ready	31.12.05	30.06.06	Quarter Report 2-05	IPJ
11	4.2.2.4	Status Report	Summary report on quality of planar arc coating	27.05.05	25.05.05	SRF Annual Meeting 05'	INFN-Ro2
12	<b>5.1.1.4</b>	<b>Final Report (D)</b>	<b>Best EP parameters</b>	<b>31.03.05</b>	28.02.06	unexp. results, not finished	CEA
13	5.1.2.2	Cavities ready	3 cavities fabricated	31.03.05	01.06.05	AnnRep-05	CEA
14	5.1.3.4	Commissioning	First operation of EP set-up	31.12.05	01.02.06	Lab safety problems	CEA
15	5.2.1.1.3	Status Report	Proof-of-Principle experiment hot water rinsing	01.11.05	31.01.06		DESY
16	5.2.1.2.3	Design report	Electrode design fixed	01.12.05	31.03.06		DESY
17	<b>5.2.1.3.5</b>	<b>Final Report (D)</b>	<b>Process parameters fixed</b>	<b>01.12.05</b>	31.03.06		DESY
18	5.3.1.4	Commissioning	First operation of automated EP	08.02.05	31.07.05	Quarter Report 1-05	INFN-LNL
19	5.3.2.4	Status Report	Software ready	21.02.05	31.07.05	Quarter Report 1-05	INFN-LNL
20	5.3.4.2	Report	Proposal for alternative electrolytes	24.05.05	31.05.06	work in progress	INFN-LNL
21	5.4.1.5	Commissioning	Installation finished	11.04.05	28.02.06	heating to modify	DESY
22	<b>5.4.2.4</b>	<b>Final Report (D)</b>	<b>Cleaning parameters fixed</b>	<b>06.10.05</b>	30.06.06		DESY
23	6.1.3.5	Commissioning	Scanning apparatus operational	16.12.05	31.07.05	Quarter Report 2-05	DESY
24	6.2.1.3	Status Report	Calibration defects finished	01.01.05	01.01.05	SRF Annual Meeting 05'	INFN-LNL
25	6.2.3.6	Start operation	Flux gate detector operational	19.12.05	19.12.05	SRF Annual Meeting 05'	INFN-LNL
26	6.3.1.7	Interim Report	First report on BCP/EP and DIC surface	10.06.05	10.06.05	SRF Annual Meeting 05'	DESY
27	6.3.2.2	Start Measurements	Start strong emitter evaluation	30.11.05	30.11.05	AnnRep-05	DESY
28	8.1.5	Design report	Report UMI tuner	10.08.05	01.09.05	SRF Annual Meeting 05'	INFN-Mi
29	8.3.4	Tuner Prototype(D)	Start of Integrated Experiments	01.06.05	31.12.05	AnnRep-05	CEA

A. ACTIVITY REPORT

30	8.4.2		Report on actuator/piezo sensor	21.03.05	21.03.05	SRF Legnaro-05	CNRS
31	8.4.4		Report on radiation hardness tests	15.08.05	15.08.05	PAC05	CNRS
32	9.1.4.4	Status Report	Report on exceptional handler operation	02.12.05	02.12.05	AnnRep-05	DESY
33	9.4.1.7	Final Report (D)	Report on data management developments	14.09.05	15.12.05	AnnRep-05	WUT-ISE
34	10.3.4	Status report	Evaluate experimental results	09.12.05	09.12.05	SRF Annual Meeting 05 <sup>1</sup>	CEA
35	11.2.9	Start Measurements	Ready for beam test in TTF	31.12.05	31.12.05	TTF (schedule) delay	INFN-Fras

**JRA1.14 List of major meetings organized under SRF during the reporting period**

<b>Date</b>	<b>Title/Subject</b>	<b>Location</b>	<b>Number of attendees</b>	<b>Website address</b>
Jan 24, 2005	WP4	Rome, Italy		
Jan 24, 2005	WP8: Magnetostrictive tuner development	DESY, Hamburg, Germany	5	
Feb 08-09, 2005	WP4	IPJ, Swierk, Poland		
Feb 15, 2005	WP9	DESY, Hamburg, Germany		
Mar 11, 2005	WP8: Preparation of magnetostrictive test characterization	IN2P3, Orsay, France	5	
Mar 18, 2005	WP7	IN2P3, Orsay, France		
Apr 01, 2005	WP8	TUL, Lodz, Poland		
May 11, 2005	EP Parameters and Experiences	Argonne, USA		none
May 20-21, 2005	WP4: Problems of the current reduction and stabilization, design of new magnetic filters	Rome, Italy	6	none
May 23-24, 2005	EP Parameter and Experiences	TJNF, USA		none
June 7, 2005	WP5: Parameters of electro polishing	CEA Saclay, France		none
Oct 19-21, 2005	Annual SRF Meeting	INFN, Legnaro, Italy	45	<a href="http://jra-srf.desy.de/">http://jra-srf.desy.de/</a>

### 1.4.2 JRA2: Charge Production with Photo-Injectors (PHIN)

The list of participants and their implication in the PHIN Work Packages (C: Coordination, X: Participation) is given in the table below. The overall management is done by INFN-LNF and by CERN.

Number	Participant	WP1 M&C	WP2 CP	WP3 LASER	WP4 GUN	Person- months
3	CNRS	X	X	X	X	113
	CNRS-LAL	X	X	X	C	50
	CNRS-LOA		X		X	63
9	FZR	X			X	40 (18)
10	INFN	C		X	X	54.5 (20.5)
	INFN-LNF	C		X	X	39.5 (13,5)
	INFN-Mi			X		15 (7)
11	TEU		X	X		4.8
17	CERN	C	X	X	X	48 (0)
20	CCRLC	X		C		18.07
	CCLRC-RAL	X		C		18.07

#### JRA2.1 Work Package 1: Management and Communication

##### JRA2.1.1 Meetings

- Two CARE Steering Committee and Dissemination Board meetings were held. The first, by teleconference, on January 21<sup>st</sup>; the second, at CERN, on April 5<sup>th</sup> and 6<sup>th</sup>.
- The CARE Annual Meeting was held at CERN on November 23<sup>rd</sup> – 25<sup>th</sup>, and a PHIN Collaboration Meeting was held in that occasion.
- Three video conferences between RAL and CERN on common activities were held on February 3<sup>rd</sup>, April 14<sup>th</sup> and August 11<sup>th</sup>.
- A RAL Internal Progress Meeting was held at the Central Laser Facility (RAL) on May 5<sup>th</sup>.
- A PHIN Laser Planning Meeting was held at RAL on June 9<sup>th</sup>.
- A Photoinjector Collaboration Meeting attended by BESSY, DESY, FZR and MBI was held in Rossendorf on February 10<sup>th</sup>.
- A Collaboration meeting on superconducting RF gun simulation results between BESSY, BINP, FZR and INFN took place in Berlin on June 2<sup>nd</sup> and 3<sup>rd</sup>.
- Three Photoinjector Collaboration Meetings attended by BESSY, DESY, FZR and MBI were held on August 15<sup>th</sup>, October 6<sup>th</sup> and October 26<sup>th</sup>.
- LAL and CERN vacuum engineers held a meeting at CERN on December 14<sup>th</sup>.
- PHIN representatives participated the 32nd Advanced ICFA Beam Dynamics Workshop on Energy Recovering Linacs, PAC Particle Accelerator Conference 2005 and the 12<sup>th</sup> International workshop on RF Superconductivity

##### JRA2.1.3 Web sites

The [Dynamic database on Photocathodes](#) is available online. This web library on photocathodes shows the information on photocathodes used in the CARE project and introduces the basic knowledge on other photocathodes.

The web page is available at the URL <http://www.fz-rossendorf.de/projects/CARE>

or via the link in the PHIN web page.

The PHIN web page, available at the URL <http://www.infn.it/phin/> has been renewed. The page provides information about the JRA, links to the participating institutes and to related web pages and activities.

A complete collection of the PHIN related documentation is also available with full bibliographic reference, including Quarterly and Annual Reports, presentations given at PHIN meetings and publications. All the documentation is accessible and continuously updated.

Every Work Package has a dedicated section which includes reports on their activities and other specific documents.

### **JRA2.1.3 External Scientific Advisory Committee**

## **JRA2.2 Work Package 2: Charge Production**

### **JRA2.2.1 Description of the work**

#### **JRA2.2.1.1 FZR**

The photocathode preparation system was completely assembled and its function was tested. It contains two pairs of evaporators for Te and Cs, the holder and heater for the cathode with temperature measurement, a motor driven shutter, a measurement aperture for the photo current, and two deposition rate monitors allowing co-evaporation. Several deposition tests were carried out and the produced layers analyzed by Rutherford back scattering (RBS) and proton induced x-ray emission (PIXE). The control electronics and software is finished.

At present the system is disassembled and the parts are being cleaned. After that, the system will be assembled again in the clean room. Then photo cathodes can be produced under clean room conditions. The cathode transfer system for the storage and transport of photo cathodes in vacuum is fabricated.

#### **JRA2.2.1.2 Twente University**

A Master report on the photo cathode work at Twente has been finished. It contains an extensive survey on CsTe cathodes available in the literature. The results from literature combined with experience from our own group led to a few interesting conclusions concerning the relation between high quantum efficiency, short live time and fast preparation. The report is available at the University of Twente web site:

<http://lf.tnw.utwente.nl/masterthesis/GraduationReport-RolfLoch.pdf>

A paper on the model for the CsTe cathodes is on preparation.

The preparation chamber for the magnesium cathodes is almost ready while the preparation of the magnesium cathodes will start soon.

#### **JRA2.2.1.3 CERN**

One of the main issues of the co-evaporation process is the management of the stoichiometric ratio between cesium and tellurium during the evaporation phase (see figure JRA2.2.1). This implies to control accurately the evaporation rate of both products.

Two different methods are under development at the CERN photoemission lab:

- Separate thickness measurement with quartz microbalance;
- Vacuum species analysis.

#### **Separate thickness measurement**

Two quartz microbalances situated on both side of the photocathode allow measuring the tellurium and cesium thicknesses. In the case of the co-evaporation (two products are evaporated simultaneously) it is mandatory that every microbalance sees only a single product, while the cathode receives the 2 in a homogeneous way. Such masks are under development, and the first tests of thickness calibrations are foreseen during autumn 2005.

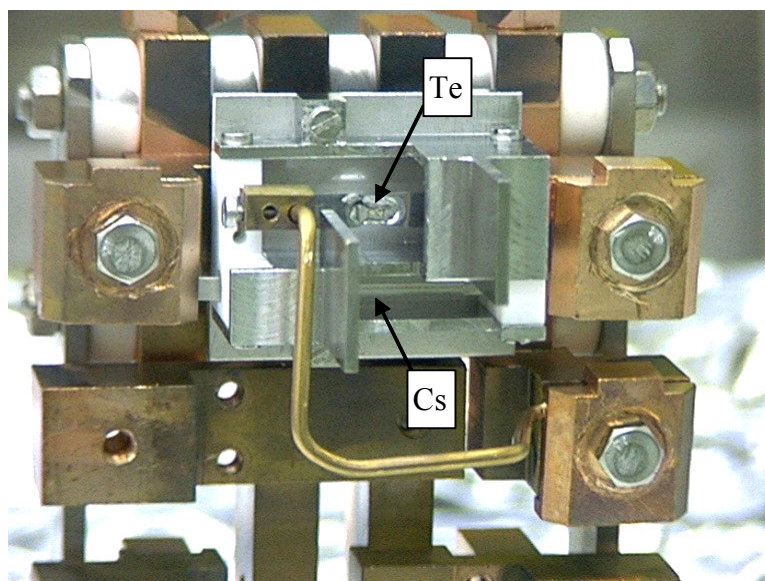


Figure JRA2.2.1; CsTe co-evaporation device.

### Vacuum species analysis

During the evaporation process, it is possible to observe a dependence of the residual gas composition inside the cathode preparation chamber with the evaporated products<sup>2</sup>. With a mass spectrometer (here a QMG 112 from Balzers), tuned to the products to be evaporated, we hope to be able to follow the evaporation rate of each product. For this purpose, a dedicated software was developed<sup>3</sup> to allow on one hand, the acquisition of the partial pressure of the residual gases before evaporation, detection of contaminants produced by the evaporators, and, on the other hand, acquisition of ionic currents produced by the evaporated products.

To be able to define partial pressures and to follow various species, it is necessary to determine the various cracking pattern and to calibrate the corresponding coefficients. For instance, on the table below, one can see the difference between the tabulated values and the measured values in a specific environment (after background subtraction) for the methane at a pressure of  $2 \times 10^{-7}$  mbar equivalent nitrogen.

Nb of mass for CH <sub>4</sub>	1	12	13	14	15	16	17
Fraction (%) from Balzers <sup>4</sup>	16.5	3	7.8	16	85	100	1.2
Fraction (%) measured	24.9	5.1	10.8	19.4	85.7	100	1.1

By doing that at different pressures and for different species, it is possible to compute the different coefficients linking the sensitivity of the spectrometer to the different species. Now, up to twenty species can be followed and recorded in almost real-time. Figure JRA2.2.2 below shows a typical spectrum of methane.

<sup>2</sup> “Closed loop multi source evaporation rate control with a quadrupole mass spectrometer in an ultra high vacuum system”, K. Wellerdieck *et al* Proc. 8<sup>th</sup> International Vacuum Congress, 22-26 September 1980, special issue of “Le vide les couches minces” No 201, Vol. II Vacuum Technology and Vacuum Metallurgy, p. 542.

<sup>3</sup> “Instrumentation d’un spectromètre de masse sous Labview”, J. Sanchez, CERN CTF3-Note, to be published.

<sup>4</sup> “Mesure de pressions partielles dans la technique du vide”, Balzers, BG 800 169PF (8310)



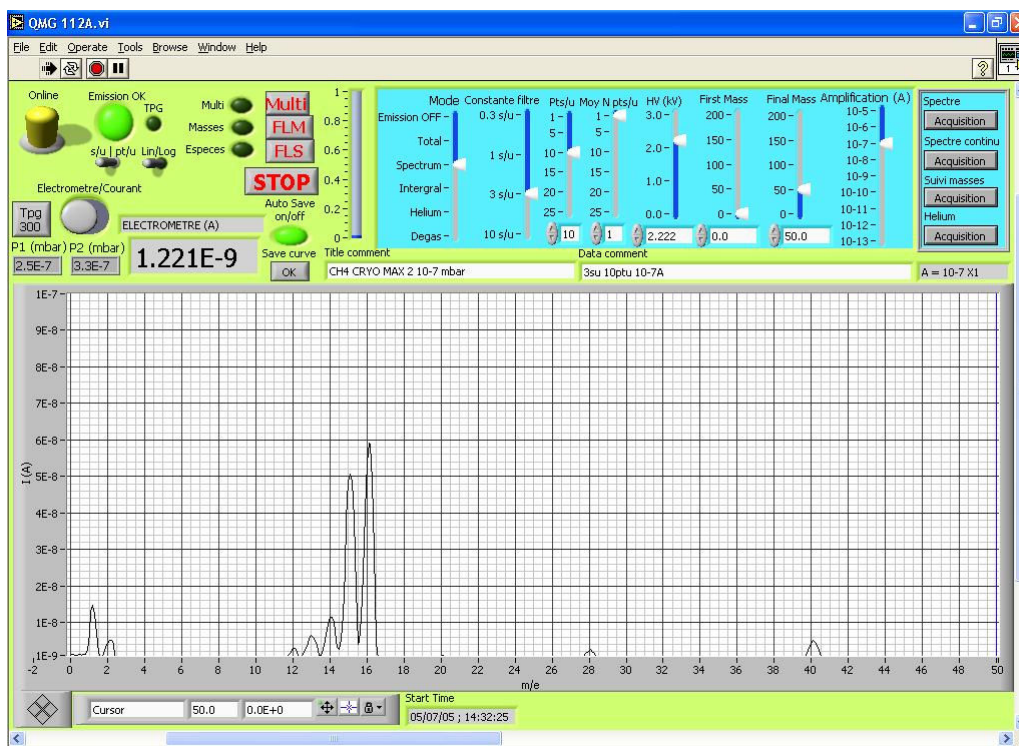


Figure JRA2.2.2: Spectrum of CH<sub>4</sub> at a pressure of  $2 \times 10^{-7}$  mbar eq. N<sub>2</sub>.

Figure JRA2.2.3 shows the spectrometer sensitivity for the different masses appearing with methane. The coefficients depend also on the pumping system (with or without ion pump, with or without cryogenic pump). An accurate vacuum gauge measures the pressure.

Injection CH<sub>4</sub> / Mesure Courant R.G.A. Balzers QMG112A en fonction de la Pression Totale Jauge Bayard-Alpert type SVT305 dans la Chambre de Préparation

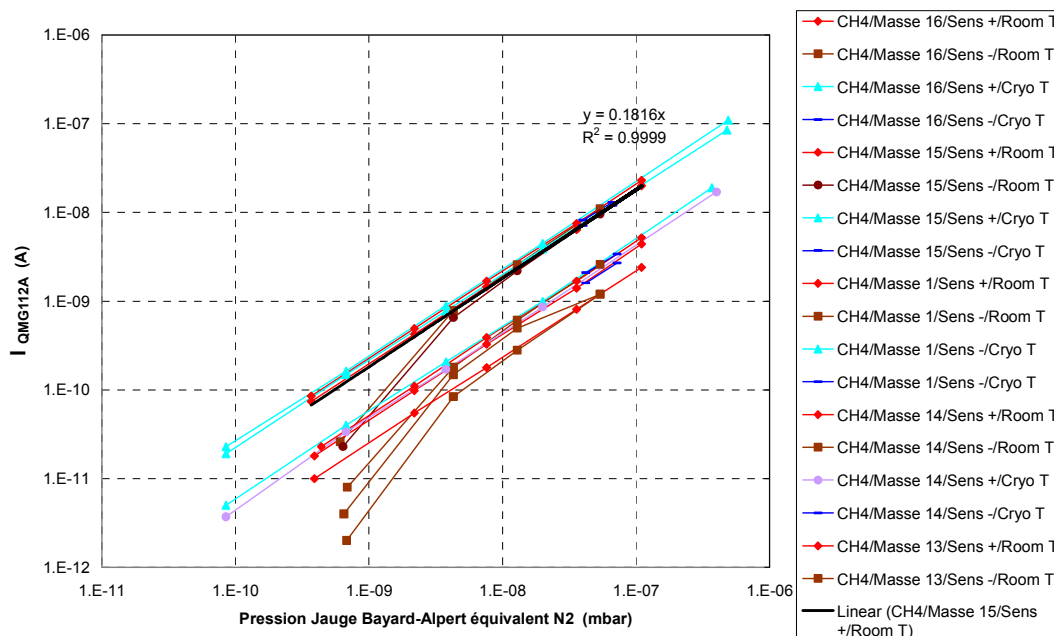


Figure JRA2.2.3: Ion current sensitivity for different masses involving CH<sub>4</sub>.

### JRA2.2.2 Overall Progress of Work Package 2

The following table highlights the progress of work planned in the year 2005 for the Work Package WP2 by listing the lowest level subtasks of the PHIN detailed implementation plan.

WP2	Title	Original begin date	Original end date	Estimated Status	Revised end date
2.1	Photocathode know-how	Jan 2004	Nov 2005	90 %	Mar. 2006
2.2	Photocathode preparation equipment	Jan 2004	Jun 2005	100 %	
2.3	Photocathode high field	Jul 2005	May 2007	0 %	
2.4	Cathode high charge SC cavity	May 2004	Jun 2006	40 %	
2.5	100 MeV monoenergetic beam	Nov 2005	Dec 2007	100 %	

### JRA2.3 Work Package 3: LASER

#### JRA2.3.1 Description of the work

##### JRA2.3.1.1 INFN-MI

###### Theoretical work

We have developed the theory of pulse shaping within non-linear crystals for the third harmonic generation. The relative simulation numerical code is under development.

We have started also the theoretical study of the diffractive effects produced by the mask both on the temporal and the spatial laser pulse profile, and the spatial modulation of the laser pulse by the mask shaper.

###### Lab work

We have proceeded with the investigation of the notable diffractive effects provided by the mask under certain experimental conditions. We have found the limits to be applied to the filter function in order to kill substantially these effects, but also the cross action of the mask and the alignment on the diffraction effect. This experimental work required the development of two beam profilers and a spectrometer for the on-line recording of the laser beam characteristics before the mask and at the near and far field.

We started the experimental investigation of the wavefront modulation of a laser beam by a mask according to a possible spatial target profile.

We started the implementation of the theoretical and technological findings at the SPARC accelerator (INFN Frascati Laboratory). The test results were positive. The simulation programs developed in Milan have shown to be very useful for achieving experimentally the searched pulse waveform and the high resolution spectrum analyzer developed in Milan has shown to be efficient for our needs.

###### Reports

The report on pulse shaping simulations and design, deliverable n.19, has been delivered.

##### JRA2.3.1.2 INFN-LNF

The SPARC laser system has been installed at the INFN National Laboratories in Frascati (LNF). Soon after the installation the laser characteristics were extensively measured and they resulted in agreement with the requirements asked to the manufacturer, Coherent.

The time jitter between the laser and the RF apparatus has been also investigated. The stabilization is achieved by controlling the laser oscillator cavity length through three actuators: a DC motor, a piezo transducer and a magnetic galvo.

Two kinds of measurement have been performed to obtain information on the phase noise in different points of the laser chain. The reference signal comes directly from the driving 2856 MHz oscillator in both cases. The first setup employs the standard phase noise detection technique: the continuous waveform originated by the laser beam at the exit of the oscillator, at the repetition rate of  $79\frac{1}{3}$  MHz, is mixed with the 36<sup>th</sup> sub-harmonic of the reference oscillator. This type of measurement is very common and quite simple to be performed, but the idea for SPARC is to obtain information also on the single laser UV pulse at the cathode at 10 Hz and to use it to build a feedback. To do this we implemented a second setup

measurement: the signal under measurement comes from a cavity tuned at 2856 MHz, fed by a high voltage fast photodiode illuminated by the laser UV 10 ps pulse with a repetition rate of 10 Hz. The pseudo-sinusoid generated by the cavity is then compared with the reference oscillator. Measurements performed over 5-10 minutes indicate that the phase noise at oscillator level varies from 650 fs to 750 fs RMS. Instead the time jitter in the UV is included in the range 630 ps to 1 ps RMS. These results satisfy the requirements of the SPARC photoinjector.

We developed, built and characterized an optical cross-correlator for UV temporal diagnostic. In fact a strategic task for the SPARC laser system is the production of time flat top laser pulse at the cathode and, obviously, this profile has to be measured. The cross-correlator showed a resolution of 250 fs (measured up to now).

This device has been used to discover a spatial chirp in the UV beam, due to the configuration of the final UV single pass stretcher that was designed by the laser manufacturer. It has also been shown, analyzing the cross-correlation traces, that the spatial chirp presence strongly influences the length of the UV pulse.

Since this effect is undesirable for the photo-emission process, the final UV stretcher has been modified on site: from the initial single pass configuration to the final double pass configuration. We checked that this final configuration does not present a relevant spatial chirp effect.

An UV spectrometer has also been designed and built to measure the UV spectrum profile with a resolution higher than 0.02 nm. The two diagnostics are important for the production of the UV flat top profile. The study on how the production of an UV flat-top pulse has to be produced has already started.

The production of these pulses is based on an acousto-optic effect which takes place in TeO<sub>2</sub> crystal. In this coming future the realization of these pulses, which has already given some good results, is going to be investigated in deeper details by comparing the experimental results with simulations coming from a code that has already been developed at INFN-Milano.

### JRA2.3.1.3 CCLRC-RAL

#### Oscillator

In May 2005 the 1.5 GHz Nd:YLF oscillator and preamplifier system was delivered by HighQLasers to RAL, via CERN. Acceptance testing at CERN and RAL showed that the specifications were fully met and the timing jitter of the system, with the oscillator synchronised to an external RF source, was measured to be <150 fs at RAL.

Parameter	Performance at Acceptance Test
Laser repetition rate	1.4993 GHz
Laser wavelength	1047 nm
Average power	10.3 W
Pulse width	5.3 ps
Beam quality	$M^2 = 1.1$
Long term pulse energy stability	0.56% rms
Timing jitter	123 fs (electronic measurement) 126 fs (optical measurement)

Table 1: The High Q Laser oscillator and preamplifier specifications

#### Amplifiers

The high power laser diodes and drivers for the first amplifier were in procurement/manufacture during this quarter and all the parts should be delivered by the end

of October 2005. The mechanical design and manufacturing of the head will have been completed by the end of August. Amplifier assembly will begin in October after installation of the diode cooling system and the safety interlocks (expected in September).

The multipass optical system has been designed in detail to provide adequate beam size in all 3 passes to achieve high gain and saturation.

Tender exercises for the high power laser diodes and drivers for the second amplifier have been completed and orders have been placed.

### **Timing Structure and Coding**

After a market survey it became clear that phase coding of the mode-locked laser pulsetrain based on a Pockels cell (i.e. inserting and removing a 333 ps delay in the pulse timing every 212 pulses) would require the development of new technology. A low-risk approach based on a fibre-optic modulator immediately after the laser oscillator is therefore being pursued. The fibre system is intrinsically lossy so additional amplification will be needed either in the amplifier chain constructed by RAL or in an additional stand-alone module by HighQLaser.

The coding system will be purchased during the next quarter for tests.

Due to high switching voltage and speed required in the main pulse-slicing Pockels cell, which will cut a 1.54  $\mu$ s train from the >200  $\mu$ s output from the amplifiers, piezo-ringing effects are expected, which will introduce undesirable intensity modulation in the output beam. A compensator based on a second, low-voltage cell and a programmable arbitrary waveform generator is under consideration to compensate for this effect. This compensator is also suitable to correct dynamic but reproducible intensity noise introduced in the rest of the laser system.

### **Control system**

Preliminary design of an electronics package to manage the relative timing of the system's powered components has begun. This package will need to support isolated operation, for laser development and testing at RAL, but must also be capable of integration with the CTF3 control system at CERN. Design considerations include limiting the scope for system instability and hardware damage resulting from timing errors. The interfacing with CERN hardware has been discussed.

### **System specifications**

The main system parameters are now being finalised. The laser pulse train duration will be 1.548  $\mu$ s containing the phase coded structure of 2332 pulses at the fundamental repetition rate of 1.5 GHz. The system will be optimised for one macropulse repetition rate, which will be 5 Hz, not 10 Hz as agreed before (the reason for this is radiation safety). The system also will be required to run at 50 Hz during the PI commissioning. The beam size on the cathode will be fixed, within the range specified by CERN. The pulse train rise and fall time will also be fixed at ~2-3 ns.

The diagnostics and the system layout have been discussed with CERN (see picture showing the planned layout of the system).

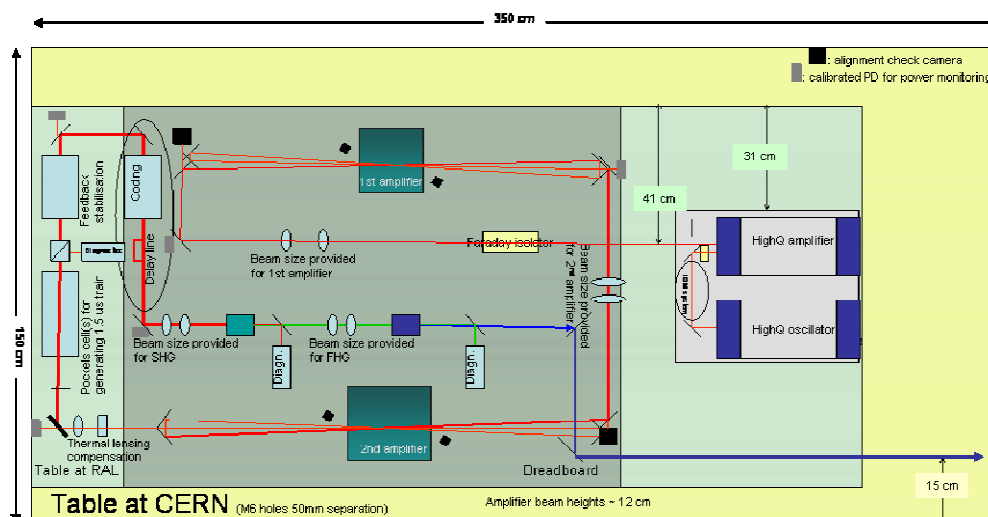


Figure JRA2.3.1: The planned layout of the system

## Reports

The report “Provision for the CTF3 Photoinjector Laser Oscillator”, deliverable n°16, has been delivered.

## JRA2.3.2 Overall Progress of Work Package 3

The following table highlights the progress of work planned in the year 2005 for the Work Package WP3 by listing the lowest level subtasks of the PHIN detailed implementation plan.

WP3	Title	Original begin date	Original end date	Estimated status	Revised end date
3.1	<b>Laser System</b>				
3.1.1	High power oscillator design	Jan 2004	Jun 2004	100%	
3.1.2	High power oscillator construction	Jun 2004	Jan 2005	100%	
3.1.3	High power amplifier design	Jan 2004	Sep 2004	100%	
3.1.4	High power amplifier construction	Sep 2004	Jul 2005	70%	Jun. 2006
3.1.5	Oscillator + amplifier test	Aug 2005	Dec 2005	70%	Mar. 2006
3.2	<b>Pulse shaping (PS)</b>				
3.2.1	PS Simulation and design	Jan 2004	Jun 2004	100%	
3.2.2	Phase mask acquisition and test	Jun 2004	Apr 2005	100%	
3.2.3	Dazzler acquisition and test	Jan 2004	May 2005	100%	
3.2.4	Pulse shaping comparison	May 2005	Oct 2005	30%	Jun. 2006
3.3	<b>UV generation and feedbacks</b>				
3.3.1	UV harmonic generator R&D	Jan 2004	Jun 2004	100%	
3.3.2	UV harmonic generator test	Jun 2004	Apr 2005	50%	Jun. 2006
3.3.3	Laser-RF feedback development	Jan 2004	Jun 2005	80%	May 2006

## JRA2.4 Work Package 4: RF GUN and Beam Dynamics

### JRA2.4.1 Description of the work

#### JRA2.4.1.1 FZR

For the SRF gun the cathode cooling system was delivered and functionality measurements in the test bench have been successfully finished. The critical point is the heat transfer from the cathode to the liquid N<sub>2</sub> cooler. Corresponding to the estimated power input from the RF field, the cathode was heated with 10 W. This causes a temperature increase from 77 K to 99 K at the cathode, which is satisfactory. In this case, the radiation power flow from the cathode to the cavity is negligibly small. The results were published at the SRF 2005 workshop.

In March, the two 3½-cell niobium cavities (RRR 300 and RRR 40) were delivered. The shape of the cavities, especially of the half-cell does not allow using existing tuning machines for TESLA cavities. Therefore a new cavity tuning machine with integrated bead pull measuring device was designed and built at FZR. For the first warm tuning step after fabrication and before chemical treatment, the designed field profile with 10 % accuracy and a  $\pi$ -mode frequency of 1.2991 GHz is envisaged. In order to tune the cells, the single iteration tuning method proposed by Cooper (Cornell University) is applied. The software was developed and RF simulations were carried out in order to obtain the needed parameters. The first tuning of the Nb RRR 40 cavity and of the Nb RRR 300 cavity is finished. In autumn the cavities were at DESY Hamburg for buffered chemical polishing and backing. In December a second rf-check and warm tuning was carried at Rossendorf and the cavities were prepared for the vertical test at 1.8 K at DESY.

A tuner test bench was developed and installed in order to measure the tuner performance at cryogenic temperature. The measurements were performed and published within a Diploma Thesis.

Most of the main components of the SRF gun cryomodule like vacuum vessel, cryogenic shield, magnetic shield and support system were fabricated and delivered in 2005. The photo cathode transfer and transport system was fabricated. The system is now being assembled and tested.

In order to connect the SRF photo gun with the existing He refrigerator of the ELBE accelerator at Rossendorf, a new He transfer line (liquid He and gas return) is needed. This He transfer line was ordered in spring 2005 and was delivered in December 2005. The installation is being carried out in the winter shut-down of ELBE December 05 / January 06.

The design of the new driver laser for the SRF gun is finished. It will be delivered in 2006. The installation of the laser beam line has been started.

In collaboration with BESSY Berlin the design of the diagnostic beam line is finished. The beam line will contain several screen stations, beam position monitors, Faraday cups and ICTs for current measurements, a c-bent magnet for beam energy and energy spread measurement, and a slit mask system for transverse emittance measurement. From Cherenkov radiation with a streak camera and from an electro-optical sampling system the bunch length will be obtained.

#### **JRA2.4.1.2 CNRS-Orsay**

##### **Construction of the CTF3 photo-injector: prototype**

The delivery of all pieces of the prototype was spread on one month between October, 18<sup>th</sup> and November, 9<sup>th</sup> date of reception of the last piece. The total delay of the manufacturer is 2 months with respect to the schedule. A picture of the prototype is shown in figure JRA2.4.1.



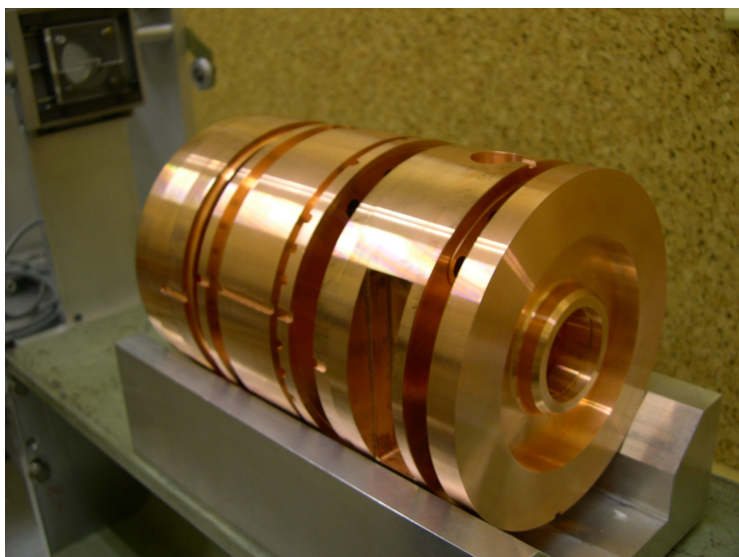


Figure JRA2.4.1: Prototype of the drive beam photo-injector.

A dimensional control of the pieces was operated at LAL, it was largely positive. The manufacturer has done a very good job, the measurements show the dimensions are well inside the tolerances given by the technical drawings. The only drawback is the delay but it was decided to keep the same company for the machining of the definitive gun because there is no guaranty that another manufacturer will do it faster and with the same quality.

The procedure of RF measurements and mechanical adjustments began in November 25<sup>th</sup>. A picture of the set-up is shown in figure JRA2.4.2 and an example of measurement in figure JRA2.4.3. Since the beginning, the coupling apertures are progressively enlarged to increase the coupling up to the nominal value. It must be done very carefully because, if the aperture is too large, there is no way to come back.

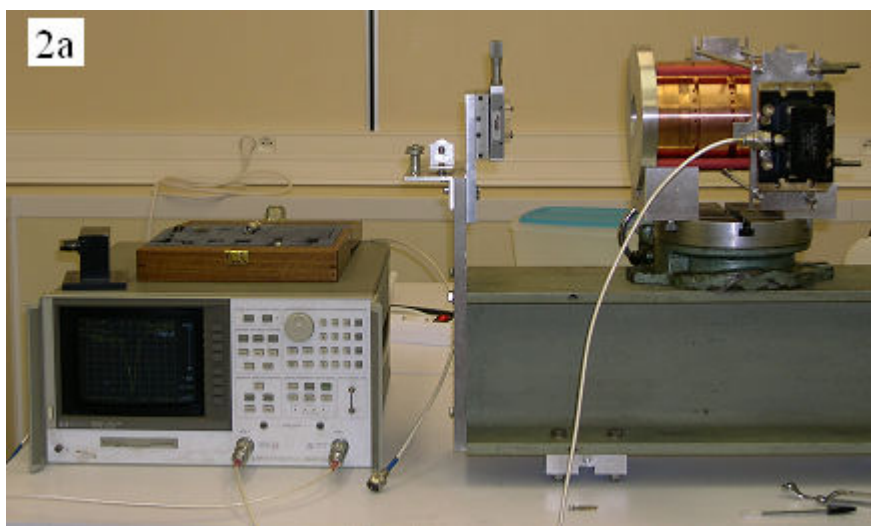


Figure JRA2.4.2: RF measurement system.

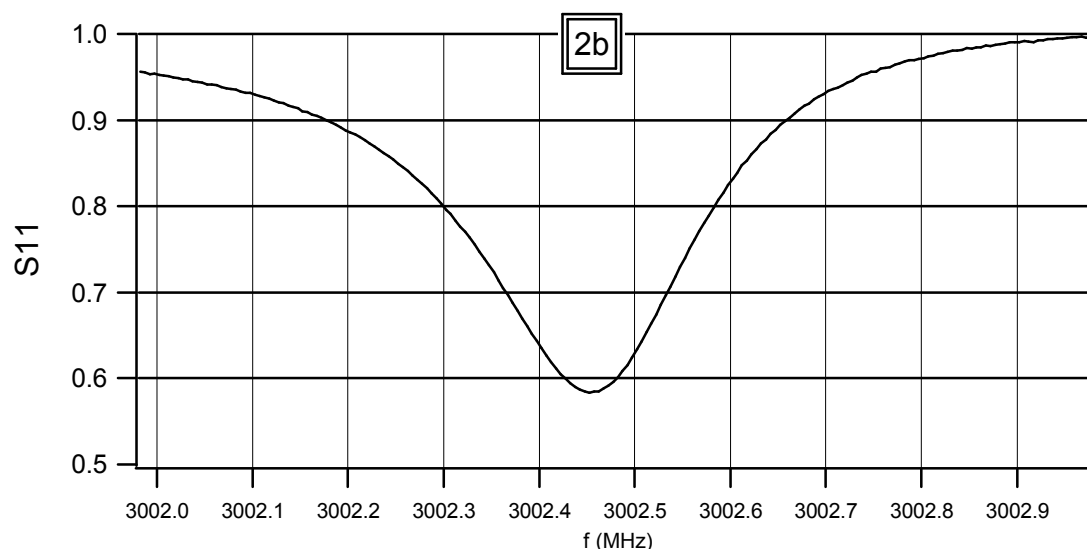


Figure JRA2.4.3: Example of a measurement of the  $S_{11}$  scattering matrix element as a function of the frequency.

In the example given in figure JRA2.4.3, the amplitude of scattering parameter  $S_{11}$  allows us to deduce a total coupling of  $\beta = 0.52$ , the dimensions of the aperture are  $22.5 \times 10 \text{ mm}^2$ . There is a discrepancy with the simulations; for the same dimensions we should have 0.67 according to the simulations. It is probably due to the limited precision in the numerical model. It means we will have probably to open the holes wider than foreseen. The measurement campaign should last until the end of January. In order to make up for the delay, we plan to order the pieces of the definitive gun before the end of the measurements. Contacts with the manufacturer have been established but the technical drawings have to be modified according to the remarks done by the CERN expert in brazing before to order the gun.

#### **Construction of the CTF3 photo-injector: vacuum and baking**

A drawing of gun simplified model dedicated to define the best implementation of heating circuits for the NEG regeneration and the baking of gun is under way in close collaboration with the CERN concerned people. In addition, this model will be used for vacuum static measurement and to check the limit pressure with respect to the simulations.

#### **Construction of the CTF3 photo-injector: coils**

The SEF Company has built and tested the two pairs of solenoids and will be delivered to LAL in the 2<sup>nd</sup> week of January.

#### **The experimental area NEPAL**

A new study of radiation safety based a new design to increase the experimental area was achieved (see figure JRA2.4.4). One example of the radiation calculations by the independent expert, S. Wurth from IPN-Orsay, is shown in figure JRA2.4.5.

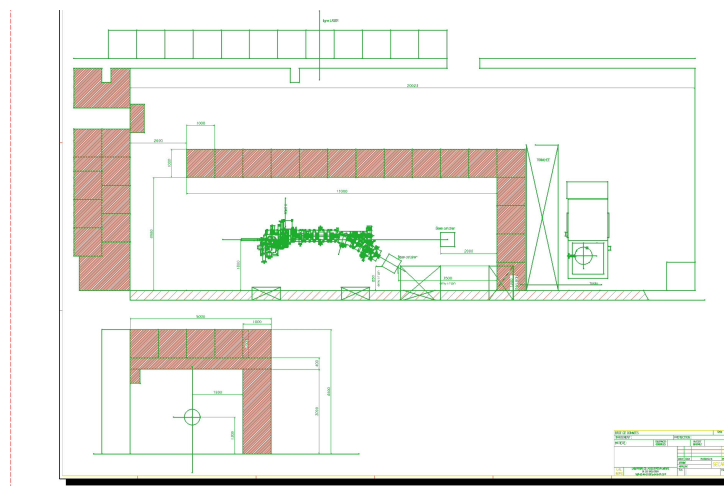


Figure JRA2.4.4: Implementation of the NEPAL test line room.

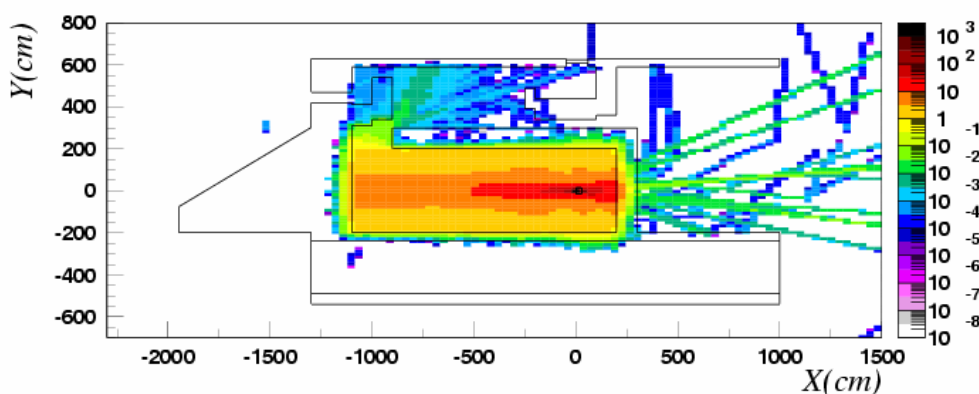


Figure JRA2.4.5: Simulation of the equivalent dose in  $\mu\text{Sv/h}$  received by beam dump for 10 MeV beam energy and 300 mW of average power.

Mostly, gamma rays are emitted when the beam collides with the beam dump. The conclusion of the expert is that the shielding foreseen in the new design is sufficient to ensure an equivalent dose below the legal threshold of  $0.5 \mu\text{Sv/h}$  in the public neighbourhood of the NEPAL hall.

The design of the beam line has begun; there are still few elements as quadrupoles and bending magnet which must be designed. Low-level RF components such as the pilot and the amplifier are available and the electronic boards for the modulator are designed. The laser room is under construction. The laser is available at OPTON LASER and will be delivered in the first half of January.

#### JRA2.4.1.3 CNRS-LOA

Design, reception and tests of the compact low energies electron spectrometer were realized according to the schedule. The compact spectrometer was designed to produce in a single shot the full energy distribution of the electron beam. This allowed us to demonstrate the “bubble regime” with the production of a quasi mono-energetic electron beam with a compact and high repetition rate laser. The parameters of this beam are: 0.5 nC in the 150-180 MeV range with a collimation angle of less than 10 mrad. This spectrometer has allowed us to follow the evolution of the electron distribution as a function of the plasma densities indicating that an optimal coupling condition is reached when the plasma period is of the order of the laser pulse duration. Quasi mono-energetic electron components (with lower charge and at lower energy) have been also observed by different groups but at higher densities in non-optimum condition.

Scheme and design of GeV laser plasma accelerators have been studied from the theoretical point of view. Both approaches, single or two stages laser plasma accelerators, seem very promising for the future of this research. This work has been carried out by a post-doc fellow funded by the contract. The second post doc funded by the contract has made experiments with the LOA team.

As we mentioned in the proposal, the use of the electron beam has been considered for application in medicine, material science and chemistry. Obviously the electron beam parameters (charge, duration and collimation) have allowed to define new applications and new sciences. As mentioned in the project, these parameters are very promising for future compact XFEL (X free electron laser) based on laser systems.

We are now starting the last mission of our contract concerning the design of a compact single shot electron spectrometer in the GeV range.

#### JRA2.4.2 Overall Progress of Work Package 4

The following table highlights the progress of work planned in the year 2005 for the Work Package WP4 by listing the lowest level subtasks of the PHIN detailed implementation plan.

WP4	Title	Original begin date	Original end date	Estimated Status	Revised end date
4.1	<b>SC RF Gun</b>	Jan 2004	Dec 2006	50 %	
4.1.1	Technology development	Jan 2004	Dec 2004	100 %	
4.1.2	SC RF Gun simulation optimization	Jan 2004	Dec 2004	100 %	
4.1.3	SC RF Gun realization	Jan 2005	Feb 2007	40 %	
4.1.4	SC RF Gun test	Mar 2007	Dec 2007	0 %	

#### JRA2.5 Significant Achievements

- CTF3 laser oscillator achieved specified performance, in particular with respect to amplitude stability and time jitter. This is the first laser in the world with 1.5 GHz pulse rate (CERN)
- Delivery of all the components for the two high power amplifiers of the CTF3 laser (CERN)
- Laser commissioning with DAZZLER pulse shaping (INFN-LNF)
- Development of cross correlation diagnostics system for UV square pulse (INFN-LNF)
- Laser synchronization with external RF at 0.5ps level (INFN-LNF)
- IR square pulse with space mask (INFN-MI)
- Delivery of the CTF3 photo injector prototype (CNRS-Orsay)
- Photocathode preparation system assembled and tested (FZR)
- Cathode cooling system delivered and functionality tested (FZR)
- High intensity electron beam from plasma (CNRS-LOA)

#### JRA2.6 List of all milestones and deliverables (D) during the reporting period

#### JRA2.7 List of major meetings organized under PHIN during the reporting period

Date	Title/subject	Location	Main organizer	Number of attendees	Web site
3/2/05	RAL-CERN Videoconference	Videoconference			
10/2/05	Photoinjector Collaboration Meeting	Rosendorf	FZR		

## A. ACTIVITY REPORT

14/4/05	RAL-CERN Videoconference	Videoconference			
5/5/05	Internal progress meeting	RAL CLF	CLF	8	
2-3/6/05	SRF gun Simulation results	Berlin	BESSY		
9/6/05	CARE PHIN laser planning meeting	RAL	RAL	4	
11/8/05	CARE PHIN progress meeting	Video conference (RAL/CERN)	RAL	11	
15/8/05	Photoinjector Collaboration Meeting	Rosendorf	FZR		
6/10/05	Photoinjector Collaboration Meeting	Rosendorf	FZR		
26/10/05	Photoinjector Collaboration Meeting	Berlin	FZR		
14/12/05	Vacuum Engineering Meeting	CERN	CERN		
23-25/11/05	CARE Annual Meeting	CERN	CERN		
23-25/11/05	PHIN Collaboration Meeting	CERN	CERN		

### 1.4.3 JRA3: High Intensity Proton Pulsed Injector (HIPPI)

The list of participants and their implication in the HIPPI Work Packages (C: Coordination, X: Participation) is given in the table below. The overall management is done by CERN.

Number	Participant	WP1 M&C	WP2 NC	WP3 SC	WP4 CHOP	WP5 BD	Person- months
1	CEA	X	X	C	X	X	45.9
3	CNRS	X	C	X	X	X	28
	CNRS-IPNO			X			8.3
	CNRS-LPSC	X	C	X	X	X	19.7
4	GSI	X				C	37.2
5	IAP-FU		X	X		X	51 (39)
7	FZJ			X		X	38
10	INFN			X		X	16 (8)
	INFN-Mi			X		X	16 (8)
17	CERN	C	X		C	X	98 (24)
20	CCLRC		X		X	X	30.94
	CCLRC-RAL		X		X	X	30.94

#### JRA3.1 Work Package 1: Management and Communication

Two Quarterly Reports and one Annual Report have been prepared, as well as the 4 Work Package meetings and the Annual HIPPI meeting.

An important organizational matter was the addition of another Institute, INFN-Naples, into the HIPPI programme. A team at this Institute has experience in Side Coupled Linac (SCL) structures, a particular type of accelerating structure that is analyzed in the HIPPI Work Package 2, coming from many years of work in the design, tuning, model measurements and prototyping of SCL structures for medical applications, in the frame of the TERA and PALME projects. They have developed some tools for the design of SCL structures and have gained a considerable experience in the RF measurements, and they offered to share them with the HIPPI teams active on the SCL (CERN and LPSC). The discussions led to the definition of a common work programme for 2006, which is now integrated in the HIPPI detailed planning. The contribution of the INFN-Naples team to the HIPPI work will come completely from the INFN budget, while HIPPI will only invite out of the Management budget a participant from INFN-Naples to report to the HIPPI Annual Meeting.

##### JRA3.1.1 Overall Progress of the Activity

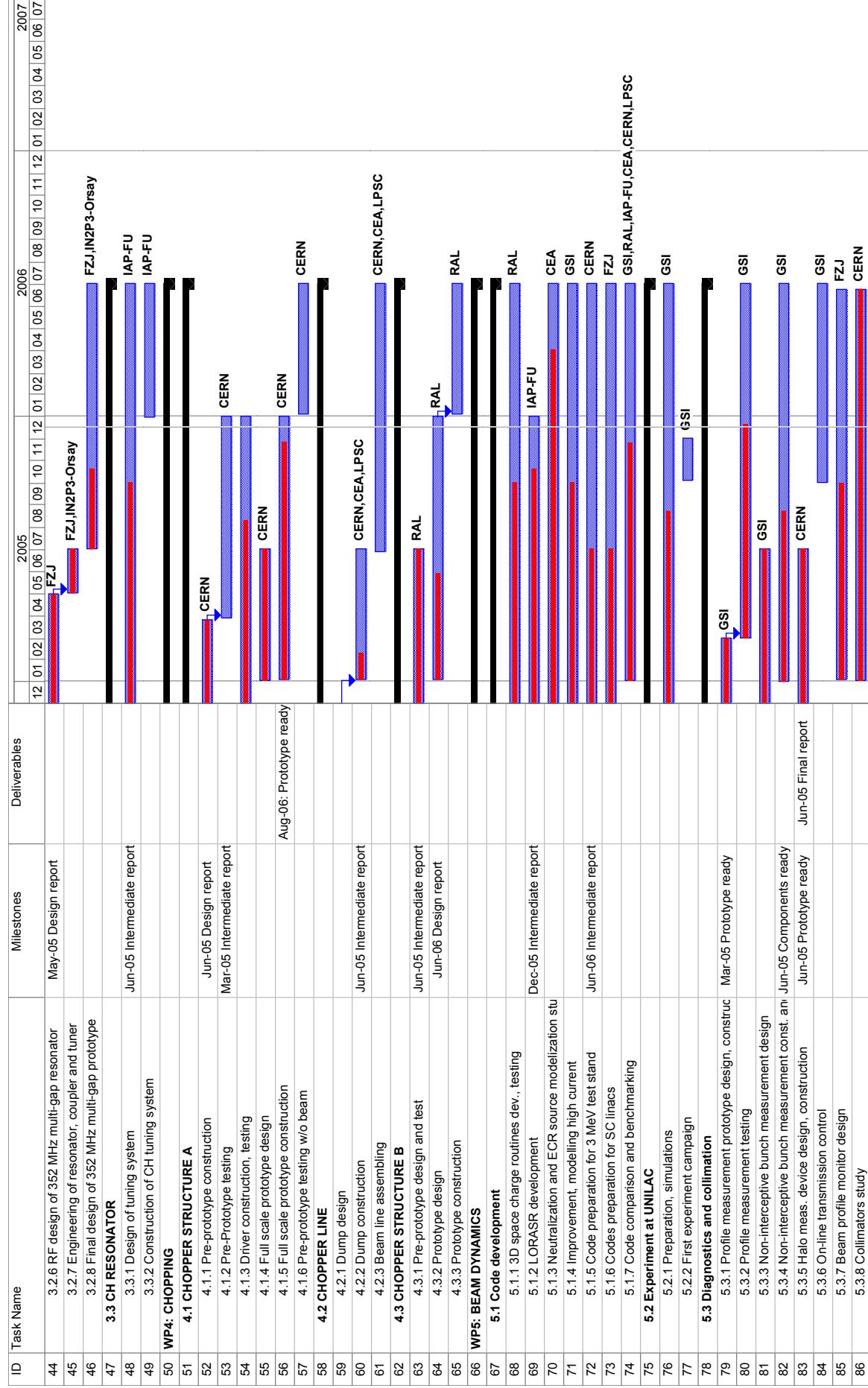
The overall progress of the HIPPI activity is described in the following Gantt chart which specifies the involvement of each contractor in the work packages and tasks.



A. ACTIVITY REPORT

ID	Task Name	Milestones	Deliverables	2005												2006												2007											
				12	01	02	03	04	05	06	07	08	09	10	11	12	01	02	03	04	05	06	07	08	09	10	11	12	01	02	03	04	05	06	07				
1	<b>WP2: NORMAL CONDUCTING STRUCTURES</b>			[Gantt chart bars for WP2 tasks]																																			
2	<b>2.1 Drift Tube Linac</b>			[Gantt chart bars for 2.1 tasks]																																			
3	2.1.1 DTL design			[Gantt chart bars for 2.1.1]																																			
4	2.1.2 Decision on prototyping			[Gantt chart bars for 2.1.2]																																			
5	2.1.3 DTL coupler prototype design			[Gantt chart bars for 2.1.3]																																			
6	2.1.5 DTL coupler prototype construction and testing			[Gantt chart bars for 2.1.5]																																			
7	2.1.4 DTL beam dynamics design			[Gantt chart bars for 2.1.4]																																			
8	<b>2.2 H-mode Drift Tube Linac</b>			[Gantt chart bars for 2.2 tasks]																																			
9	2.2.1 RF model CH tank1 RF design			[Gantt chart bars for 2.2.1]																																			
10	2.2.2 RF cold model design & construction			[Gantt chart bars for 2.2.2]																																			
11	2.2.3 RF model construction			[Gantt chart bars for 2.2.3]																																			
12	2.2.4 Beam dynamics design CH tank1			[Gantt chart bars for 2.2.4]																																			
13	2.2.5 CH model cavity tests	Dec-05 Intermediate report		[Gantt chart bars for 2.2.5]																																			
14	2.2.6 CH-prototype design			[Gantt chart bars for 2.2.6]																																			
15	2.2.7 CH-prototype construction			[Gantt chart bars for 2.2.7]																																			
16	2.2.8 CH+DTL beam dynamics study	Jun-05 Design report	Dec-06: Prototype ready	[Gantt chart bars for 2.2.8]																																			
17	<b>2.3 Side Coupled Linac</b>			[Gantt chart bars for 2.3 tasks]																																			
18	2.3.1 RF model RF design			[Gantt chart bars for 2.3.1]																																			
19	2.3.2 RF model mechanical design			[Gantt chart bars for 2.3.2]																																			
20	2.3.3 RF model construction and testing			[Gantt chart bars for 2.3.3]																																			
21	<b>2.4 Cell Coupled Drift Tube Linac</b>			[Gantt chart bars for 2.4 tasks]																																			
22	2.4.1 Pre-prototype construction	Jun-05 Intermediate report		[Gantt chart bars for 2.4.1]																																			
23	2.4.2 Pre-prototype high-power RF tests			[Gantt chart bars for 2.4.2]																																			
24	2.4.3 Contribution to ISTC prototype construction	Jun-06 Prototype ready		[Gantt chart bars for 2.4.3]																																			
25	2.4.4 Revision of design after prototype testing		Dec-06: Design report	[Gantt chart bars for 2.4.4]																																			
26	<b>WP3: SUPERCONDUCTING STRUCTURES</b>			[Gantt chart bars for WP3 tasks]																																			
27	<b>3.1 ELLIPTICAL CAVITIES</b>			[Gantt chart bars for 3.1 tasks]																																			
28	3.1.1 Cavity A vertical tests			[Gantt chart bars for 3.1.1]																																			
29	3.1.2 Tuner design			[Gantt chart bars for 3.1.2]																																			
30	3.1.3 Integration of piezo design			[Gantt chart bars for 3.1.3]																																			
31	3.1.4 Tuner construction and testing	Dec-05 Intermediate report		[Gantt chart bars for 3.1.4]																																			
32	3.1.5 Design cavity B			[Gantt chart bars for 3.1.5]																																			
33	3.1.6 Construction cavity B		Jun-06: cavity B ready	[Gantt chart bars for 3.1.6]																																			
34	3.1.7 Power coupler design & engineering			[Gantt chart bars for 3.1.7]																																			
35	3.1.9 RF coupler construction			[Gantt chart bars for 3.1.9]																																			
36	3.1.8 RF source order & preparation			[Gantt chart bars for 3.1.8]																																			
37	3.1.10 Modulator preparation for 700 MHz test stand			[Gantt chart bars for 3.1.10]																																			
38	<b>3.2 SPOKE CAVITIES</b>			[Gantt chart bars for 3.2 tasks]																																			
39	3.2.1 Test stand preparation at FZJ			[Gantt chart bars for 3.2.1]																																			
40	3.2.2 Evaluation of 760 MHz resonator in vertical cryo	Mar-05 Intermediate report		[Gantt chart bars for 3.2.2]																																			
41	3.2.3 Evaluation of 352 MHz 2-gap res. in vertical cryo	Oct-05 Intermediate report		[Gantt chart bars for 3.2.3]																																			
42	3.2.4 Design of coupler prototype			[Gantt chart bars for 3.2.4]																																			
43	3.2.5 Test of coupler prototype			[Gantt chart bars for 3.2.5]																																			

A. ACTIVITY REPORT



## JRA3.2 Work Package 2: Normal Conducting Accelerating Structures

### JRA3.2.1 Drift Tube Linac (DTL)

#### JRA3.2.1.1 Activities at Rutherford Laboratory (RAL) (WBS 2.1.4)

A recent slow-down in the RAL activities was experienced owing to a restructuring of the group involved in HIPPI: F. Gerigk joined CERN as well as, recently, G. Bellodi. A new recruit (C. Plostinar) joined RAL at the beginning of April on a 3-year HIPPI fellowship contract.

The work done at RAL for WP2 is in conjunction with progress on the RAL Front End Test Stand work. A re-assessment of the frequency for the new ISIS injectors has been carried out and a choice of 324 MHz has finally been agreed.

Initial contacts have taken place with Toshiba Electronics for the provision of RF klystrons at this frequency, and first quotations were received for their 3MW/324MHz/50pps/620 $\mu$ s model, as supplied to the JPARC project in Japan).

A re-design of the 180 MeV H<sup>-</sup> linac upgrade for ISIS at the new frequency value has just begun.

The first provisional scheme would be based on an as yet unspecified number of DTL cavities accelerating the beam from 3 to 90 MeV, followed by an SCL section (up to 180 MeV) operating at 972 MHz. The DTL is presently made of a 4 tank DTL with 207 cells.

Work has started on the DTL tanks design using SUPERFISH (Gen\_DTL), with some exploration of the inter-dependences between various physical quantities (shunt impedance, Kilpatrick, face angle, diameter) in the search for optimal design parameters.

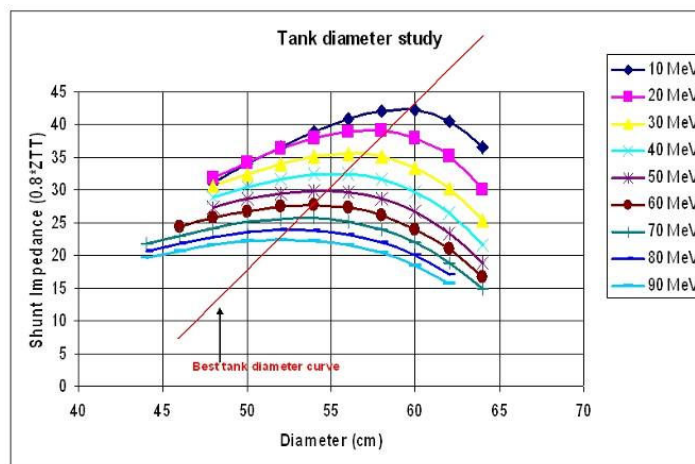


Figure JRA3.2.1: Shunt impedance as a function of the tank diameter for different energies.

#### JRA3.2.1.2 DTL general design at CERN, LPSC, CEA (WBS 2.1.1 to 2.1.4)

A DTL Task Force has been set up, following the Frankfurt HIPPI yearly meeting (2004) and met five times at CERN between December 04 and June 05. The goal of the task force was to set up a team of experts in order to converge to a modern optimised design for the DTL of Linac4, providing a stronger coordination of ongoing activities and a closer guidance to the construction of the DTL Tank1 "working prototype" that is now starting in Russia.

A new beam dynamics design has been defined, with higher accelerating gradient (3.3 and 3.5 MV/m), no field ramp in the first tank, FFDD focusing in Tank1 and FD in the following tanks. Correspondingly, the RF design has been recalculated, keeping peak field below 1.7 Kilpatrick and maximum peak power out of the klystrons below 750kW. The Tank1 layout resulting from this work has been sent to ITEP (Moscow), and will be followed for the

mechanical design of the Tank. The Permanent Magnet Quadrupoles have been further studied at CERN, in particular for the effect on beam of errors and multipoles.

The beam dynamics design of the first tank is now finalized, in particular with the definition of an error budget for alignment, mechanical, magnetic and RF errors, supported by a set of beam dynamics simulations. Moreover, the validity of some essential beam dynamics choices like the synchronous phase was confirmed by a consistent set of simulations.

A visit of a CERN team to VNIIEF Sarov, in charge of the mechanical construction of a DTL Tank1 prototype has been extremely useful to define the technologies that can be used to build a state-of-the-art DTL tank. In particular, has been retained the principle of separated alignment of the drift tubes with respect to a supporting girder, and the option of laser welding of drift tubes containing permanent quadrupoles, allowing the magnets to be outside of the vacuum. A further meeting at CERN at beginning of December 2005 has allowed defining more details of the design.

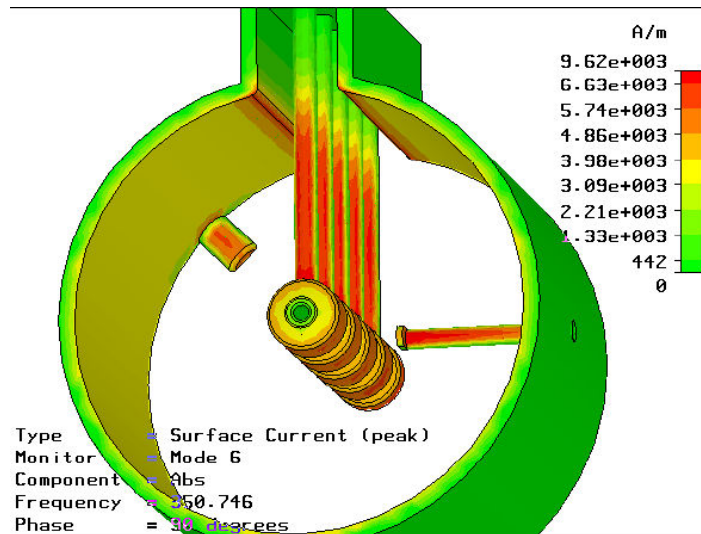


Figure JRA3.2.2: A simulated section of DTL Tank1 showing surface currents. Are visible the drift tubes with supporting stems, the post-coupler (right) and a tuner (top left).

### JRA3.2.1.3 DTL and coupling port design at CEA Saclay and LPSC (part of WBS 2.1.3)

As planned, the RF design of the coupling port for 1 MW RF power has been performed by CEA Saclay. The final design uses a standard, half height waveguide terminated by a short circuit and coupled to the tank by an “evanescent waveguide” of rectangular shape. The distance between the short circuit and the “evanescent waveguide” dictates the coupling factor. Therefore, by changing the position of the short circuit, one can adjust the coupling factor, by example to be adapted for different accelerating field levels or beam currents.

The influence of the power coupler on the shunt impedance of the tank has been verified. No decrease in shunt impedance could be observed, which indicates that the effect of the PC is lower than the RF code precision.

The thermal load and its geometrical repartition on the coupler has been computed both for the full reflection and full transmission cases, the practical running point lying somewhere in between, as close as possible from the 100% transmission case. The power to be used for the thermo-mechanical design is the one corresponding to the 100% transmission case with a 20% safety margin, leading to losses of some 3.5 kW cw.

Thermal calculations have been done at LPSC as well as the mechanical design. These thermal calculations have shown that acceptable temperatures are achievable and a cooling system solution has been proposed (CARE report 5-0010).

The upper part of the system (from the RF port flange to the DTL tank) will be built by the VNIIEF Sarov team from the LPSC data and will be part of the tank. In particular, the power

exchange is only 44 W from the connecting guide to the DTL. Constraints studies have been finalized, showing no difficulty. The lower part will be built by LPSC and is made of the RF window, the wave guide and the adjustable short circuit.

The activity is on time. The solution is presented on figures JRA3.2.3, JRA3.2.4 and JRA3.2.5.

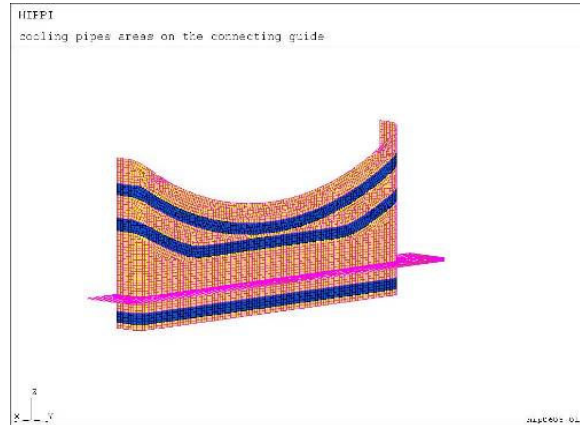


Figure JRA3.2.3: Cooling structure: the rose part represents the flange, the upper part is the connecting guide to the DTL tank, and the lower part is connected to the waveguide.

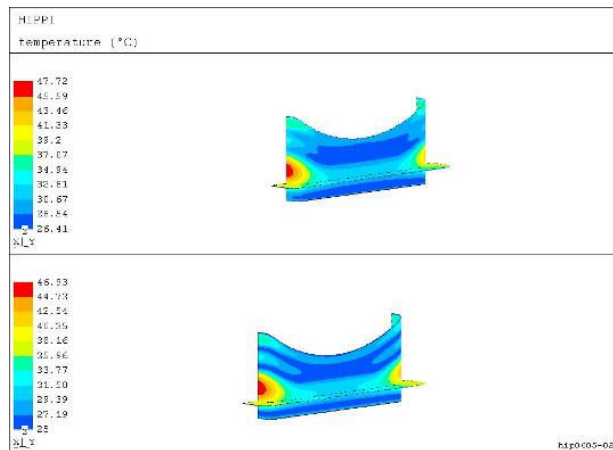


Figure JRA3.2.4: The maximum temperature increase is 23 degrees Celsius. The cooling pipes have to be as close as possible to the DTL tank. The upper part of the figure represents the inner face of the connecting guide, the lower the outer.

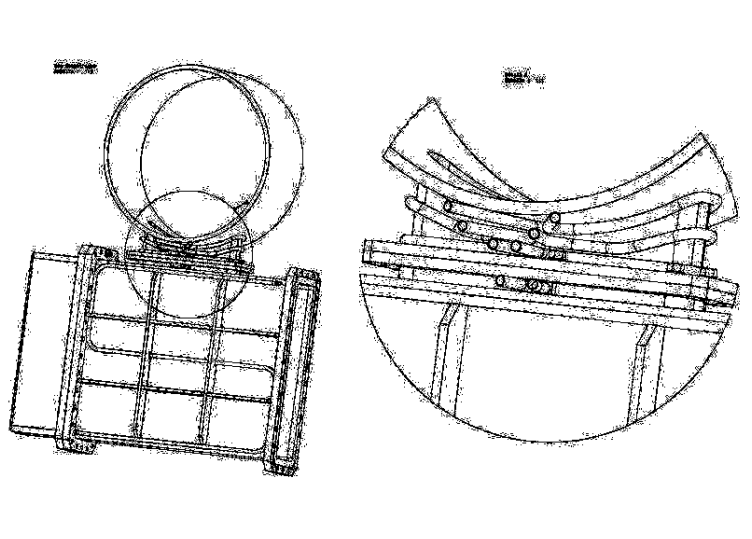


Figure JRA3.2.5: General overview of the coupling port.

### JRA3.2.2: H-mode DTL (IAP Frankfurt)

#### JRA3.2.2.1 Beam dynamics design (WBS 2.2.4)

The beam dynamics investigation for the 70 mA, 70 MeV, 352 MHz Proton Injector for the FAIR Project at GSI has been completed by use of the LORASR Code and the main results are summarized in the specific CARE NOTE 2005-16 HIPPI.

Several RFQ-Output distributions, generated with the PARMTEQ Code and representing realistic samples of RFQ beam at 70 mA, were employed to design the whole linac lattice and, in particular, to design the matching section between the CH-DTL and the RFQ.

The new MEBT design, as shown in Fig. JRA3.2.6, includes a short quadrupole singlet lens followed by a short rebuncher and, finally, a quadrupole triplet at the entrance of the first CH-DTL; free space to host diagnostics devices is located in front of the first lens as well as in front of the rebuncher. Full structure calculations both at 70 and 95.7 mA show the definitive possibility to accept 3 MeV as initial energy together with full transmission rate and an acceptable emittance growth.

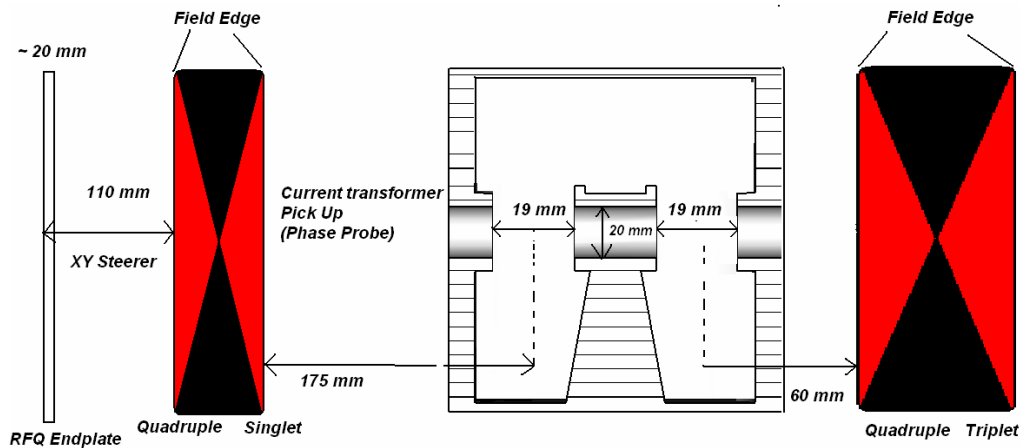


Figure JRA3.2.6: The proposed matching section between the RFQ and the first CH Tank.

To reach the final energy of 70 MeV several configurations were tested and analyzed: finally, we propose a technical solution made by 11 tanks including 50 cm of free space for an extended diagnostics region after the fifth tank. As shown in Fig. JRA3.2.7 a dynamic aperture of 20 mm combined with a triplet aperture of 30 mm is safe enough against losses along the whole structure.

The main parameters of this structure are listed in Tab. 4.1: compared to conventional linac designs, the increase in acceleration gradient is obvious.

Tank	KONUS Period	Energy Gain (MeV)	RF Losses (kW)	Beam Load (kW)	Accelerator Gradient (MV/m)	Max. Axial Field (MV/m)	Peak Voltage (KV)
1	3 x -45° + 7 x 0°	2.7	592	190	6.25	160	433
2	3 x -35° + 10 x 0°	4.6	599	326	7.01	150	524
3	3 x -35° + 11 x 0°	5.5	535	385	5.9	150	620
4	3 x -35° + 12 x 0°	6.6	535	463	5.8	110	586
5	4 x -35° + 12 x 0°	7.0	444	489	4.7	90	574
6	4 x -35° + 12 x 0°	7.2	408	504	4.2	80	565
7	4 x -35° + 12 x 0°	7.2	368	503	3.95	80	562
8	4 x -35° + 12 x 0°	7.2	340	506	3.65	70	565
9	4 x -35° + 11 x 0°	7.0	340	488	3.57	60	569
10	3 x -35° + 11 x 0°	6.7	343	469	3.47	60	581
11	3 x -35° + 10 x 0°	5	215	353	2.7	60	585

Table 4.1



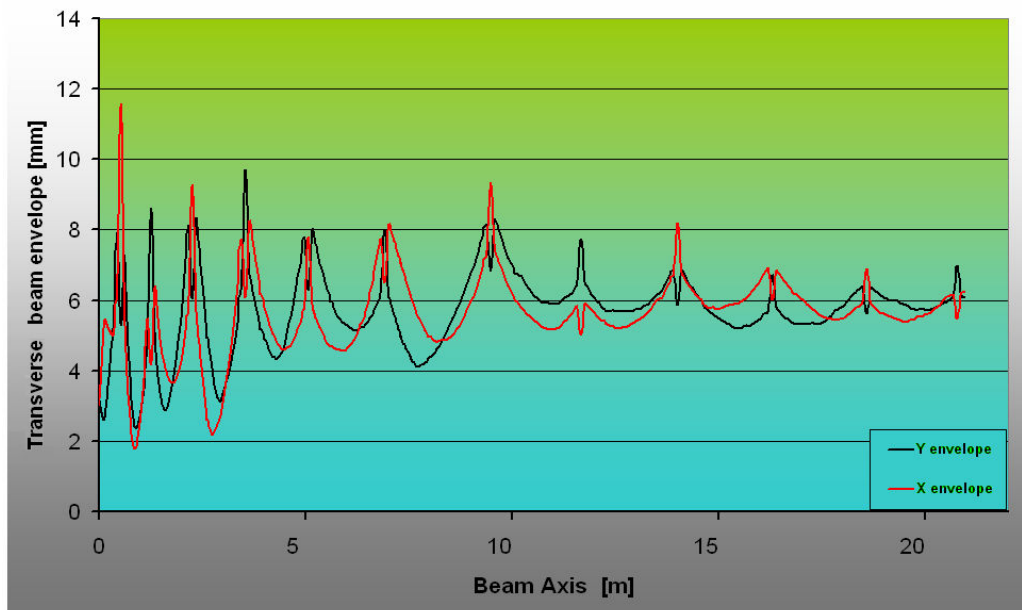


Figure JRA3.2.7: 99 % transverse envelope of the GSI Proton Injector.

#### *JRA3.2.2.2 RF cold model design & construction (WBS 2.2.2)*

There is still a lack in experience with this novel type of accelerator. That's why, in order to test fabrication steps and find out technical solutions, a cold model cavity consisting of 8 equidistant gaps is under construction: the experience gained with this model will be transferred in the realisation of the prototype cavity foreseen for 2006.

In a first step, Microwave Studio design was performed in order to optimize the main parameters of the model cavity (resonance frequency, Q-Value, shunt impedance).

Finally, to increase the voltage in the end-cells and to achieve a good flatness of the electric field one possible way is to increase the magnetic inductance at the cavity ends. In the IH cavity for instance, this can be obtained by large undercuts in the base girder.

For the GSI Proton Injector design no girder is foreseen and the tuning can be achieved by enlarging the end tubes: this drift space can be used to host the quadruple lens or some beam diagnostics device such as phase probes. As shown in Fig. JRA3.2.8 and JRA3.2.9, the linac design will result in a good flatness of the field distribution together with a very compact structure where each tank will be connected with the following one. In this way the longitudinal beam dynamics which depends upon short intertank sections, profits a lot.

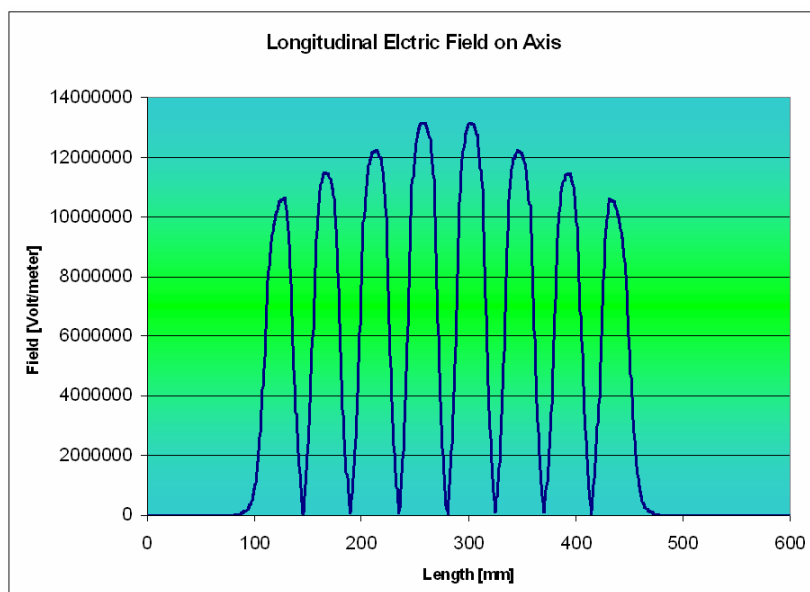


Figure JRA3.2.8: Microwave simulation of the expected axial electric field along our model.

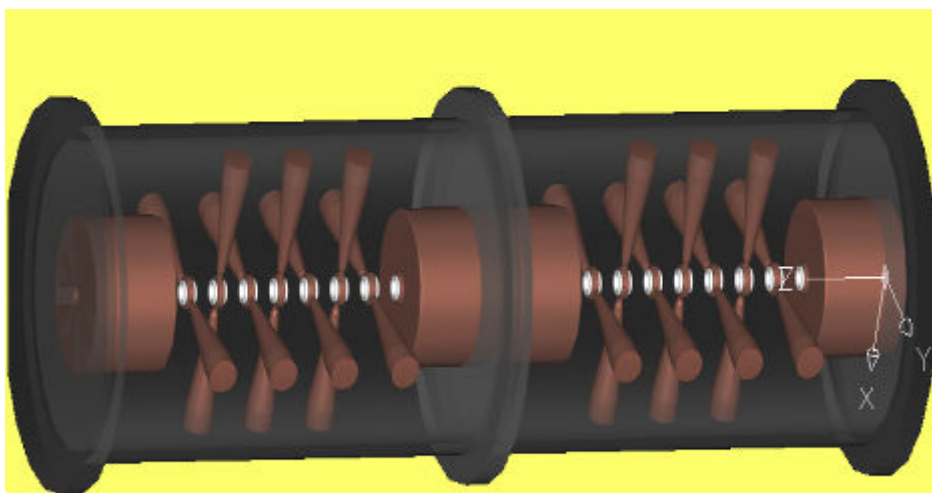


Figure JRA3.2.9: The new end-cells concept showing the compactness of the new proton injector.

Concerning the construction, all components have been built and the cavity is now under preparation for final assemblage and copper plating at the GSI Workshop; preliminary vacuum tests of the stems were already performed successfully.

The idea is to weld the stainless steel stems into the cylindrical cavity wall avoiding any screws inside the cavity; massive copper half drift tubes will be press-fitted into the stems - see Fig. Figure JRA3.2.10 and Figure JRA3.2.11 - and it is expected to achieve excellent RF contacts and mechanical precision with this technique. In this way the cavity will gain high flexibility regarding the tuning of the electric field.

Mechanical test of this technique is, at the moment, under performance in our workshop in order to benchmark the mechanical simulation obtained with the ANSYS code.

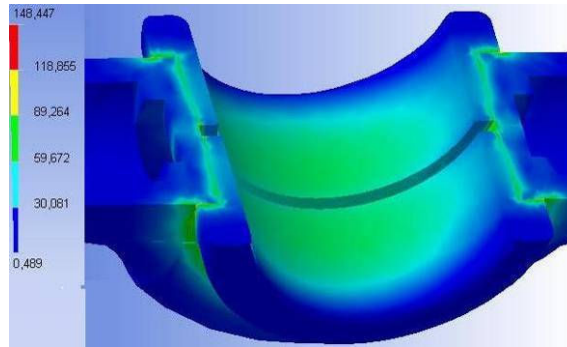


Figure JRA3.2.10: ANSYS simulation showing how the press-fit technique can ensure optimal mechanical contact between the stem and the half drift tubes.

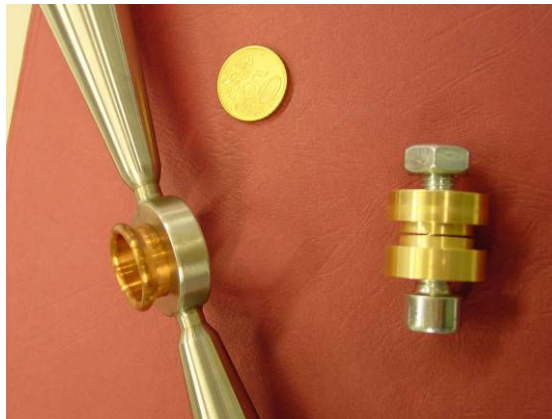


Figure JRA3.2.11: Picture of the stem and the insert that will be press-fitted. On the right side the tool that will be used for the press-fitting operation is shown.

*Note:* In order to avoid any ambiguity, we recall that the initial cold model issues (at the beginning of the HIPPI programme) were shifted from RF aspects to the investigation of mechanical design and fabrication options (see also the first HIPPI annual report).

**JRA3.2.3 Side Coupled Linac (LPSC and CERN) (WBS 2.3.1 and 2.3.2)**

An Excel tool has been developed at CERN to allow SCL design with a variety of free parameters. The present layout of the SCL section has been completed and is summarized in table 4.2. In parallel, PSPICE simulations have been performed to estimate the acceptable frequency errors on the accelerating and coupling cells. It has been shown that coupling factors of 3% guarantees low field error (with 50 kHz tuning accuracy) with minimum reduction in Q-value. This is confirmed by the error studies performed at LPSC (see below).

Klystron [#]	Tanks/Kly. [#]	Gradient E0 [MV/m]	Power/Kly. [MW]	Energy [MeV]	N cells/tank [#]
1	5	4	3.00	107.42	11
1	5	4	3.06	125.16	11
1	5	4	3.15	144.16	11
1	4	4	2.59	160.2	11
	(5)		(3.24)	(164.31)	
Tot. Klystr. [#]	Tot. tanks [#]	Average Grad. [MV/m]	Tot. Power [MW]		Tot. Length. [m]
4	20	4	12.46		28.02

Table 4.2: SCL layout

As already indicated, a delay is due to the lack of the PhD student foreseen for the activity at LPSC. The slow down of the other activities at LPSC, leading to some availability of the RF engineers have solved partially this problem. The RF design including thermal calculations, has been done for mid-2005, and is now followed by the design of the RF model.

Analytical studies, as well as simulations, have been made to calculate the sensitivity of the system versus the mechanical errors due to the machining. Analytical studies have shown the scaling laws of the field fluctuations versus the mechanical tolerances. A simulation tool, developed with the formal code Maple, has confirmed these results and has given the numerical values of the sensitivities. In parallel, RF calculations have been made to evaluate the requirements for a tuning ring. Solutions exist, without leading to too complicated structures. A final choice has been done on the choice of the optimum coupling factor and the final drawing of the cavity has to be made. This takes into account:

- The really achievable mechanical tolerances. The main impact is on the cost.
- A good balance between a small coupling factor and good shunt impedance.

The error studies have shown that, even with a large coupling factor (and hence a low quality factor), the mechanical tolerances are too strong to avoid a mechanical tuning after construction. So, the conclusions are that a tuning ring is mandatory, and the best coupling factor has to be 3%.

The coupling slot has now to be studied carefully (its shape for example) to minimize the dispersion of the coupling factor  $k$  from one coupling cell to the other one. In fact, a dispersion of the different  $k$  values will lead to inhomogeneities in the accelerating field, but this study is independent on the prototype design and construction.

A long period student (6 months) at started mi-April at LPSC in the mechanical group and has been in charge of the mechanical design and thermal studies. This has been done for several cavity schemes, to choose the best cooling system. Solutions exist but show that a 15% duty cycle is the upper limit of such a system.

Several thermal studies and cooling scenarios have been investigated. An example is given below. The cooling philosophy is to control the accelerating frequency by water temperature tuning and to design the cooling system in order to keep the stop band (due to the change of the resonant frequency of the coupling cell) below 100 kHz. So, thermal but also displacement studies have been performed to fulfil these requirements and a solution is now proposed.

An important conclusion is that the current design is acceptable. In particular, there is no need to increase the copper thickness between to adjacent accelerating cells (leading to a lower  $Q$  value).

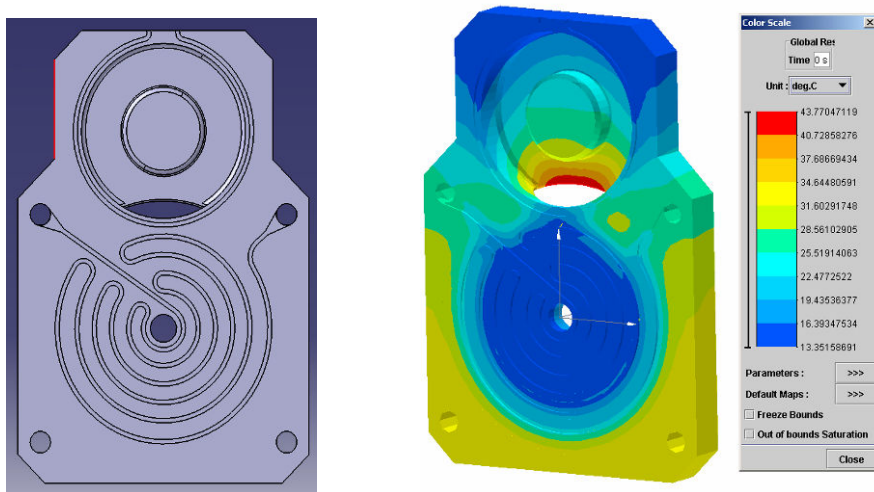


Figure JRA3.2.12: Cooling system for the SCL cavities (left) and temperature chart (right).

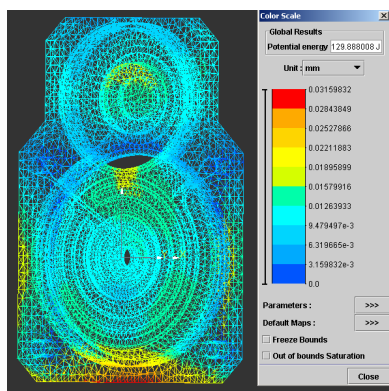


Figure JRA3.2.13: Displacements inside the cavity.

This solution has been proposed this solution to the Russian team from ISTC, in charge of the technological model, to investigate the technological feasibility, especially in terms of brazing.

The next steps will be

- To continue to investigate the real feasibility of the solution, in terms of brazing
- To launch the construction of the cold model at LPSC. The goal of the model will be to check RF calculations, to investigate the tuning procedures, and to finalize the cavity design. A trainee student will be in charge of a bead-pull bench design.
- To study, in parallel, the optimization of the coupling slot

#### JRA3.2.4 Cell Coupled DTL (CERN) (WBS 2.4.1 to 2.4.3)

The CCDTL pre-prototype built at CERN has been copper plated at beginning 2005 (Fig. JRA3.2.14). The long preparation proved to be essential to the result, the first half tank being homogeneously plated at the second attempt, while the other at the first attempt. A measurement of surface roughness after plating gave Ra of about 1  $\mu\text{m}$ , a value that should guarantee a reduction in surface conductivity below 10%. After plating, the pre-prototype has been assembled, and the drift tubes have been successfully aligned and welded (Fig. JRA3.2.15). When assembled, the pre-prototype has been equipped with temporary tuners, pick-ups, and with the RF power coupler (Fig. JRA3.2.16). After some rounds of tuning the pre-prototype could be easily tuned within 642 kHz of the operating frequency, with a stop band of 679 kHz. These values are considered satisfactory for the preliminary tuning, and they will be further improved during the final tuning stage. A bead-pull measurement (Fig. JRA3.2.17) of electric field along the prototype shows a correct field distribution, with total field error 5 %, in good agreement with the measured frequencies and already close to the final goal of 4%. The measured coupling between tanks and coupling cell was 0.86%, very close to the value predicted by 3D simulations, 0.83%. The Q-value is 21'000, still only 65% of the 2D (Superfish) calculated value, but expected to improve when the final tuners will be installed. The coupling between waveguide and cavity allows a perfect (-35 dB) matching, and the measured coupling factor  $\kappa$  is in perfect agreement with 3D simulations. This round of measurements was finished at the end of June, and then the RF coupler was sent to copper plating in the CERN workshop. It has been received only at the beginning of November, the reason for the long delay being the priority given by the CERN workshop to other activities and the need for repairs after the plating. After assembling, the final round of RF measurements will start only at the end of November, and the high power RF tests will have to be delayed to beginning of 2006.





Figure JRA3.2.14: Copper-plating of CERN CCDTL pre-prototype.

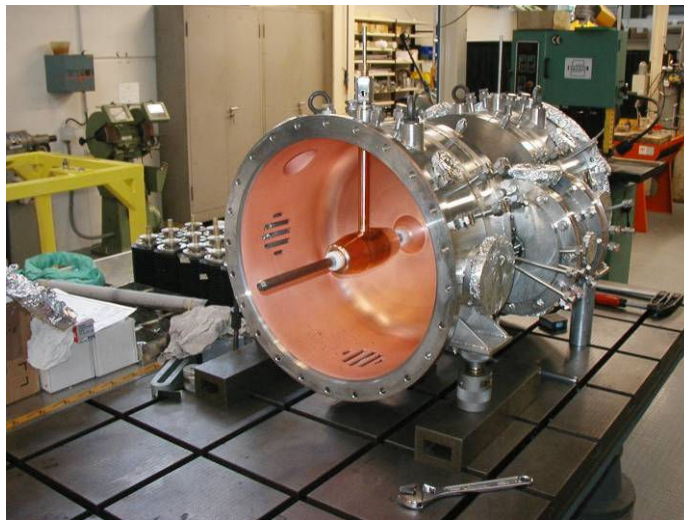


Figure JRA3.2.15: Alignment of the drift tube inside the CCDTL pre-prototype.



Figure JRA3.2.16: The assembled CCDTL pre-prototype. On the bottom can be seen the waveguide coupling port.



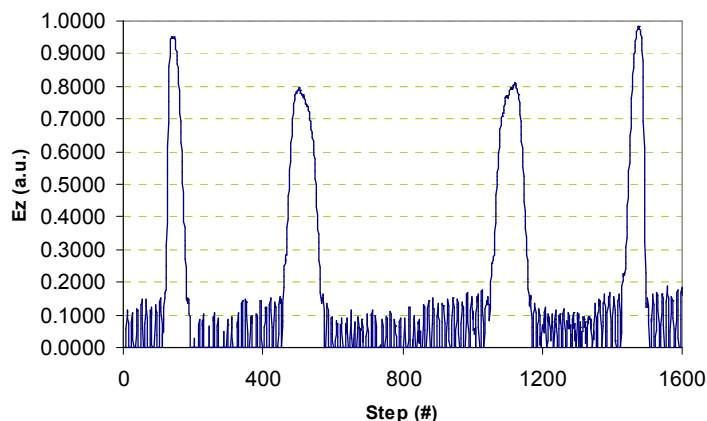


Figure JRA3.2.17: Bead-pull measurement of longitudinal electric field on axis.

In parallel to the pre-prototype preparation, the layout of the CCDTL for CERN Linac4 has been re-optimised for a higher accelerating gradient (shorter linac and lower cost) and for maximum peak power of 750 kW out of each klystron (40 mA beam current). The present design is made of  $n$  three-tank modules. An analysis of beam centroid motion in the presence of alignment errors of RF gaps and quadrupoles has confirmed that the beam is about one order of magnitude less sensitive to errors in the gap positioning than to errors in quadrupole positioning. The conclusion was that machining and positioning errors as high as  $\pm 0.3\text{mm}$  can be tolerated.

In 2005 all the design details for the next CCDTL prototype that will be built in Russia have been defined, the mechanical drawings have been finished and approved by CERN. Whilst the cost for the construction of this prototype is covered by the ISTC, general design and testing are made within the HIPPI Activity. This prototype (Figure 18) will consist of 2 full tanks, connected by a coupling cell, installed on a rigid support. One tank is terminated with a coupling cell connection, to allow future extension to a full module by adding a third tank. Construction has started during summer at the Snezhinsk workshop (Figure 19), and is expected to finish in February 2006. Then the prototype will be sent to BINP Novosibirsk for mounting the drift tubes and for a first round of RF measurements. Final delivery to CERN is expected in July 2006, in agreement with the HIPPI planning.

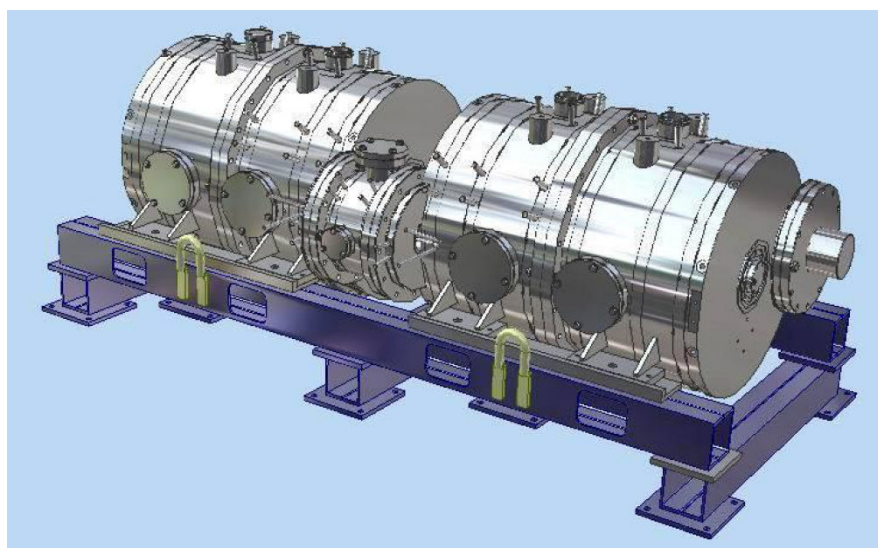


Figure JRA3.2.18: 3D view of the CCDTL prototype.



Figure JRA3.2.19: A half tank on a vertical lathe.

### JRA3.2.5 Overall Progress of Work Package 2

The following table highlights the progress of work planned in the year 2005 for the Work Package WP2 by listing the lowest level subtasks of the HIPPI detailed implementation plan.

WP2	Title	Original begin date	Original end date	Estimated Status	Revised end date
<b>2.1</b>	<b>Drift Tube linac</b>				
2.1.1	DTL Design	Jul. 2004	Jun. 2007	On time	Unchanged
2.1.2	Decision on prototyping	Apr. 26, 2004	Apr.26, 2004	100 %	Sept. 2004
2.1.3	Prototype component development	May, 2004	Jun. 2007	On time	unchanged
2.1.4	DTL beam dynamics design	Jan., 2004	Jun., 2008	On time	unchanged
<b>2.2</b>	<b>H mode DTL</b>				
2.2.1	RF model CH tank 1, RF design	Jan.04	Aug., 2004	See note	See note
2.2.2	RF cold model design & construction	Jan., 2004	Jan., 2005	90%	Apr. 2006
2.2.3	RF model construction	Dec., 2004	Jun., 2005	40%	Dec 2006
2.2.4	Beam dynamics design CH tank 1	Jan., 2004	Jun., 2004	100%	Jun. 2005
<b>2.3</b>	<b>Side Coupled Linac</b>				
2.3.1	RF model, RF design	Jan., 2004	Jul., 2004	~90%	<i>End 2005</i>
2.3.2	RF model mechanical design	Jul., 2004	Dec., 2004	Needs 2.3.1	<i>End 2005</i>
<b>2.4</b>	<b>Cell Coupled DTL</b>				
2.4.1	Pre-prototype construction	Jan., 2004	Jun., 2004	100%	Apr. 2005
2.4.2	Pre-prototype high power RF tests	Jul., 2004	Mar., 2005	delayed	Oct. 2005
2.4.3	Prototype mechanical design	Jan., 2005	Dec., 2005	90%	On time

## JRA3.3 Work Package 3: Superconducting Accelerating Structures

### JRA3.3.1 Activities at INFN-Milano

#### *JRA3.3.1.1 Cavity A vertical test (task 3.1.1)*

The report associated to the completion of Task 3.1.1 (“Cavity A vertical tests”) has been issued and published on the CARE site as CARE Note-2005-001-HIPPI.

#### *JRA3.3.1.2 Mechanical design of tuner (subtask 3.1.2) and Integration of piezo design (task 3.1.3)*

These tasks for the design of a fast/slow coaxial tuner have been started and are at approximately 80% completion. The work is in parallel with JRA1(SRF)/WP8, where a similar tuner is investigated for the 1.3 GHz cavities. Prototypes of coaxial tuners (without the piezo-assisted fast tuning capability) have been successfully operated at DESY during the SuperStructures tests at the TTF.

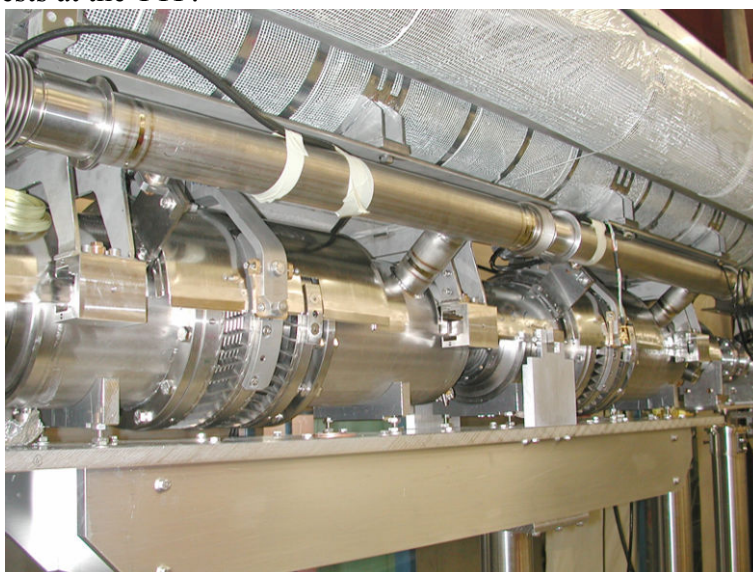


Figure JRA3.3.1: Tuning system on a TTF superstructure.

A fast tuning action, for the Lorentz force compensation under pulsed operation, has been now integrated on the coaxial tuner concept, as shown in the picture below. Two piezos actuators, preloaded by the cavity elasticity, have been included to allow the fast tuning capability. Activities for the investigation of commercially available piezoelectric elements at cryogenic temperatures are well underway in various laboratories, including Milano, in the context of the JRA1/WP8 activity. The HIPPI tasks mentioned before will benefit from the outcome of these activities in order to set the final tuner design on the basis of needed preload conditions and stroke reduction at cryogenic temperatures.

A complete structural model of the 3D behaviour of the tuner-cavity-helium tank system has been developed in order to completely characterize the system and to set up proper FE models to assess displacements/stresses in operating conditions.

Starting from the analyses performed on the 1.3 GHz tuning system, we have scaled to the dimensions of the TRASCO Z502 cavity (Cavity A), as shown in Figure 4.3.2. A fine tuning of the overall system has then been performed by means of FE analysis for complete characterization of the system.

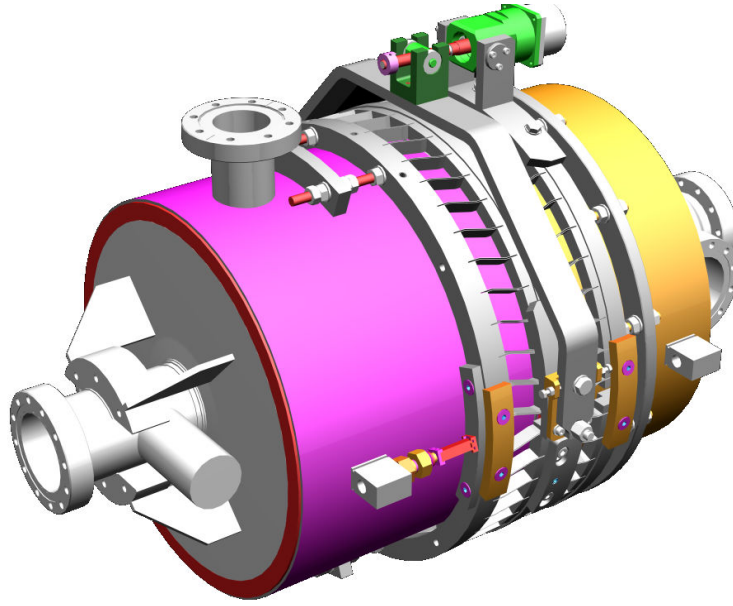


Figure JRA3.3.2: Tuning system for the Cavity A.

The main mechanical aspects of the cavity have been fully characterized, in terms of their effect on the RF frequency, in order to define the design boundaries for the tuner. The calculations for the static Lorentz Force Detuning (LFD) have been extended to the entire multicell cavity geometry and for arbitrary mechanical boundary conditions. The following table resumes the main cavity parameters.

Table 1. Cavity A mechanical/RF characterization

<i>Spring Constant and tuning sensitivity</i>	
$K_{cav}$	1.248 kN/mm
$\partial f / \partial z$	353.4 kHz/mm
<i>Vacuum load behaviour (constrained)</i>	
Frequency vacuum coefficient (constrained), $K_V^\infty$	84.72 Hz/mbar
Longitudinal reaction force coefficient at boundary, $R^\infty$	3.7 N/mbar
<i>LFD Characterization (constrained)</i>	
Static $K_L^\infty$ , with constrained boundary	-3.71 Hz/(MV/m) <sup>2</sup>
Longitudinal reaction force coefficient at boundary, $F^\infty$	-0.177 N/(MV/m) <sup>2</sup>

The two load cases described in the table above can be accurately generalized to the case of an arbitrary boundary condition, characterized by its longitudinal stiffness  $K_{ext}$ , via the following relations:

$$K_L(K_{ext}) = K_L^\infty + \frac{\partial f}{\partial z} \frac{F^\infty}{K_{ext} + K_{cav}} \quad \text{Hz}/(\text{MV}/\text{m})^2$$

$$K_V(K_{ext}) = K_V^\infty + \frac{\partial f}{\partial z} \frac{R^\infty}{K_{ext} + K_{cav}} \quad \text{Hz}/\text{mbar}$$

This generalization allowed to correctly interpreting the experimentally determined LFD of the Saclay/JLAB measurements, mainly determined by the low stiffness of the cavity supports.

Two different cavities of the shape of Cavity A (INFN cavities Z501 and Z502) have been measured several times in the last years, demonstrating the possibility to reach the design



gradients with a sufficient margin. However, the RF measurements indicated a rather big value for the static LFD coefficient, with a rather large spread in the data. The data is for the six tests (three at Saclay on the Z502 and three at Jlab for the Z501) are shown in Fig. 4.3.3, with the corresponding  $K_L$  values from the curve fits. The evaluation of  $K_L$  ranges from  $-3.7 \text{ Hz}/(\text{MV}/\text{m})^2$  in the fully constrained condition to  $-54 \text{ Hz}/(\text{MV}/\text{m})^2$  in the free cavity case, according to the analyses described before.

The stiffness of the test environments in the two experimental conditions at Saclay and Jlab has been extensively modelled, in order to verify the simulation schemes with the measurements. The two support structures, shown in the Figure below, are very different: the Jlab titanium cage constraints the cavity at the He tank dishes positions, whereas the stainless steel Saclay support imposes a constraint at the cavity flanges.

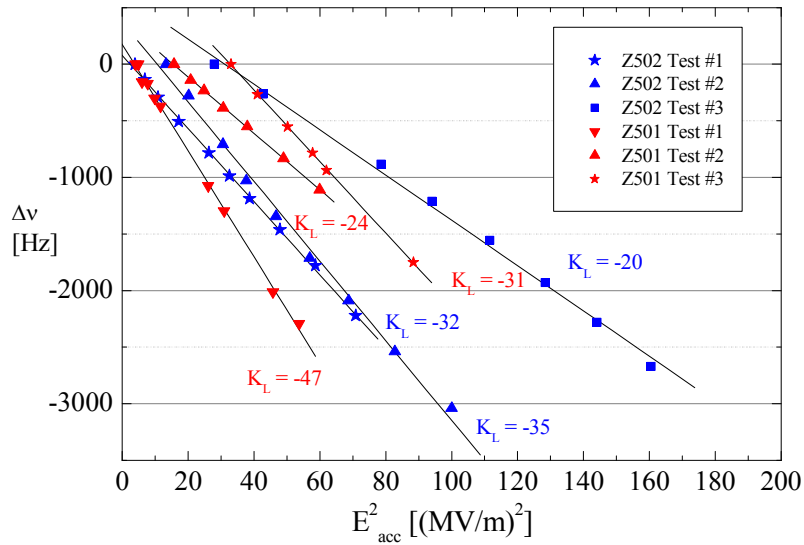


Figure JRA3.3.3: Static LFD coefficients for the Z501/Z502 cavities.

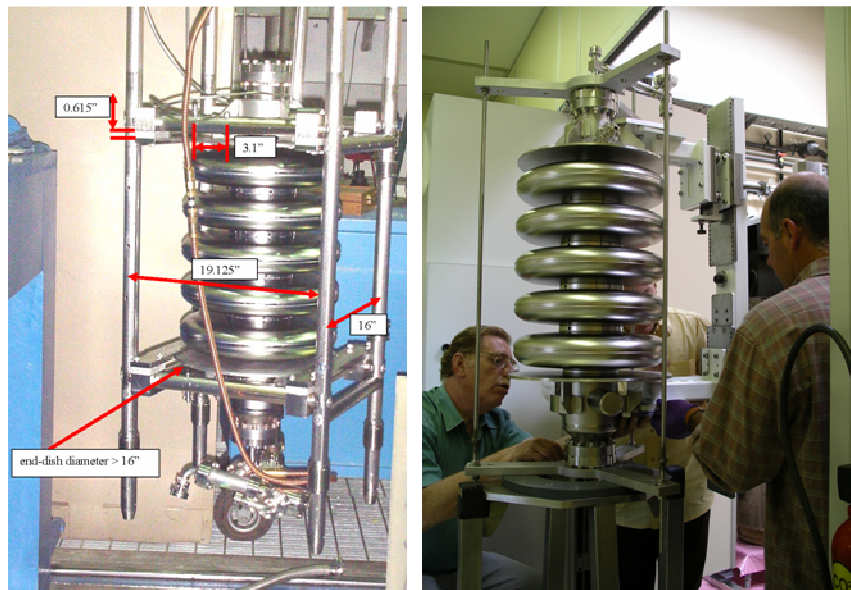


Figure JRA3.3.4: The test environment in Jlab (left) and at Saclay (right).

Structural calculations of the two support structures yield a stiffness of 0.93 kN/mm for the Jlab case and 2.39 kN/mm for the Saclay case. Fig. 4.3.5 compares the experimental LFD from the measurement with the estimations discussed before.

In both cases the external stiffening system has roughly the same stiffness of the cavity itself, thus providing a very weak constraint to the change of its length due to the action of the electromagnetic fields. The measured LFD coefficient is thus nearly that of a “free” (unconstrained) cavity, with a rather large spread due to the uncertainty of the mechanical fixtures.

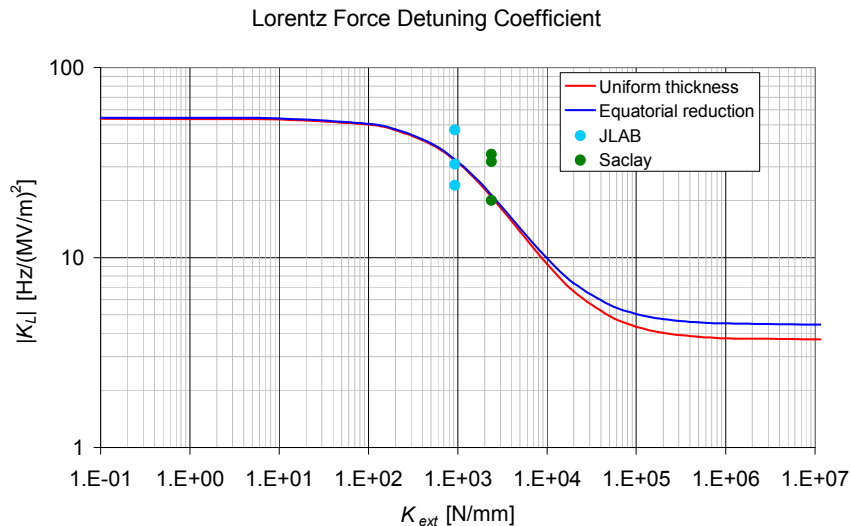


Figure JRA3.3.5: Comparison of the measured LFD coefficient with estimations, as a function of external stiffness.

The mechanical characterization of the cavity thus obtained has been used to finalize the tuner design and set the choice of subcomponents, in terms of required performances (motor, leverage and piezo excursions). As of November, we are producing the final drawings and the fabrication specifications to start the tuner and Helium tank procurement through industry by the end of the year. It is expected to have the tuner and tank available by mid 2006. The final tuner design will be presented in the intermediate report foreseen by the end of 2005.

#### *JRA3.3.2.1 Preparation of the 700 MHz test stand (task 3.1.8)*

#### *JRA3.3.2.2 Post-analysis of cavity A vertical tests performed in 2004 (LFD studies)*

During INFN cavity A tests in vertical cryostat at Saclay, the measured Lorentz detuning coefficients  $K_L$  were higher than expected from numerical simulations. In a first step, we re-performed calculations of  $K_L$  coefficients on cavity A with two different set of numerical codes at CEA-Saclay and INFN-Milano and found a very good agreement. Since mechanical boundary conditions are extremely important for  $K_L$  evaluation, we have investigated the stiffness of the existing cavity holding frame used at Saclay using CASTEM FEM code. The computed stiffness is 2.4 kN/mm which is very weak, and still over evaluated due to model simplifications.

Another approach was used in order to evaluate this stiffness from the experiments. Using the data on the detuning versus He pressure when cooling down to 1.7 K one gets  $df/dP = -426$  Hz/mbar. The coupled structural/RF calculations of the detuning when varying the external stiffness and applying He pressure on the cavity allows one to determine the  $k_{ext}$  that corresponds to the measured  $df/dP$ . For  $k_{ext} = 1$  kN/mm, one gets  $df/dP = -400$  Hz/mbar



which is very close to the measured value. In conclusion, the frame stiffness was found to be very low, and the high values of measured Lorentz detuning coefficient, which were close to the “free ends” case, are now fully understood. The study of a new frame is started in order to be able to perform the future measurements with “fixed ends” boundary conditions.

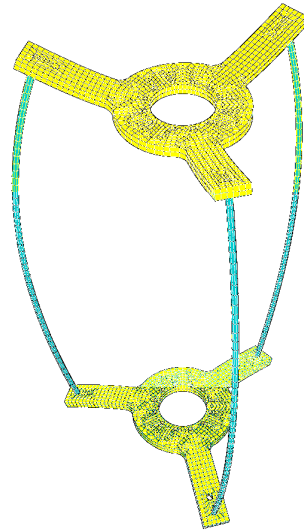


Figure JRA3.3.6: Deformation of the cavity holding frame.

#### JRA3.3.2.3 Design of cavity B (task 3.1.5)

Cavity B, the second elliptical cavity of the program, is a 5-cells 704.4 MHz with a  $\beta=0.47$ . As we aimed to test this cavity with a high power coupler (above 300 kW and possibly up to 1 MW), 100 mm diameter coupler and coupling port have been chosen, justified by the multipactor studies already done last year, and a 130 mm beam tube is required for having  $Q_{ex}$  lower than  $10^6$ . We investigated two different geometries: with asymmetric tubes (resp. 130mm and 65 mm diameters) and with same conical beam tubes (130 mm diameter ending by 65 mm flanges). For both geometries, main parameters (R/Q,  $E_p/E_{acc}$  and  $H_p/E_{acc}$ ) are very similar. However, considering the RF frequency shift versus the Lorentz force modulation frequency, the symmetric solution is better since the lowest mode at 90 Hz disappears completely.

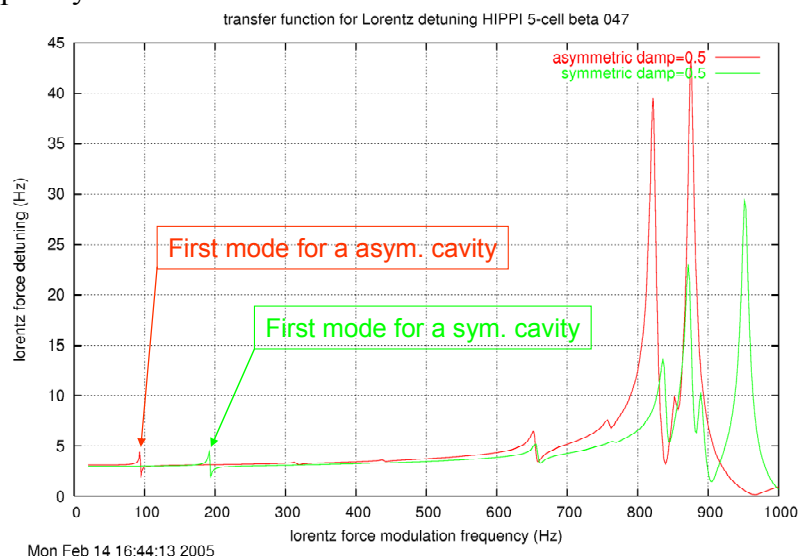


Figure JRA3.3.7: Transfer function for Lorentz detuning of cavity B with helium tank.

Moreover, the use of two sets of stiffening rings welded on the half cells is has been confirmed. Their respective radii have been optimized in one hand for lowering the static  $K_L$  of low frequency mechanical modes, and in the other hand for limiting the cavity stress to acceptable values (40 MPa). The best arrangement was found to be : iris radius = 40 mm, first stiffener radius = 62.5 mm, second stiffener radius = 110 mm. With these parameters, calculations of static Lorentz detuning for a 4 mm cavity thickness show that for a global stiffness (tuner + helium tank) around 100 kN/mm, a LFD coefficient under 4Hz/(MV/m)<sup>2</sup> can be reached.

	Stiffness [kN/mm]	Tuning sens. [kHz/mm]	tuning stress [MPa/mm]	Tuning range [kHz] @ 300K assuming $\sigma_y = 40$ MPa
1 set of rings @ r=62.5 mm	1.06	343	24	+/- 570
2 sets of rings @ r=62.5 and 110 mm	2.25	308	49	+/- 250

Design of the cavity B is now finished. Full 3D-model and detailed drawings are available. The drawings of the cavity with its helium tank are now finalized.

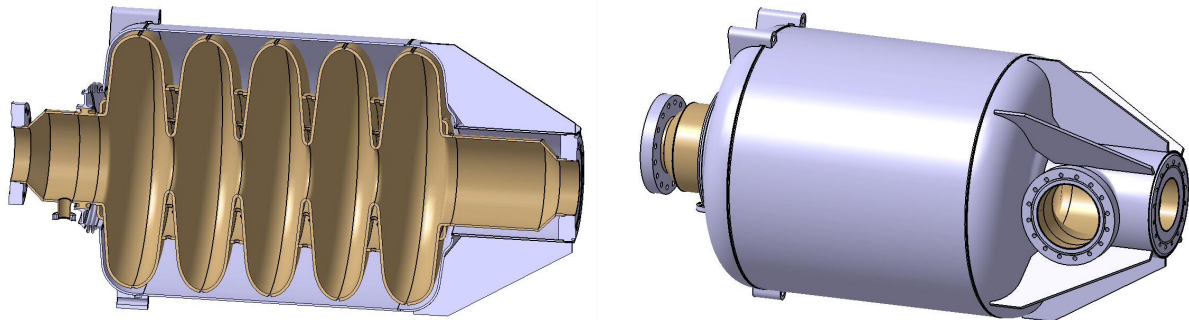


Figure JRA3.3.8: Sketches of cavity B with its two sets of stiffening rings (left) and with its Helium tank and coupler port (right).

#### JRA3.3.2.4 Construction of cavity B (subtask 3.1.6)

The niobium material (sheets, disks and tubes) necessary for the cavity fabrication is in progress and should be supplied before the end of the year. The specifications for the realization of the cavity with its helium tank are prepared in parallel, and order should be placed before the end of the year 2005.

#### JRA3.3.2.5 Power coupler design and engineering (subtask 3.1.7)

In this program, we aim to design and test a 1MW power coupler. Though this power level is not necessary for the beta 0.5 elliptical cavity, the same coupler, if properly working, could be used with all the different elliptical cavities of a linac (particularly in the high energy part). In the SNS and KEK designs, the coupler is equipped with one coaxial warm window and the coaxial part of the coupler is cooled with helium gas. We adopted the same basics, mainly because it leads to the simplest designs. RF optimization of a 704 MHz coaxial window is done. The bandwidth is large enough, and  $Q_{ex}$  lower than  $10^6$  can be reached with a 130 mm

diameter beam tube if the iris/coupler distance is kept below 50 mm. The thermal calculations for the window and the coaxial part are undertaken.

The RF design of the power coupler is almost finished. We also began the mechanical drawings, since a lot of interfaces (with the cavity, the thermal shield, the vacuum tank, ...) have to be considered and correctly designed before going on in the thermal and mechanical calculations. Preliminary set of coupler drawings should be available for December 2005.

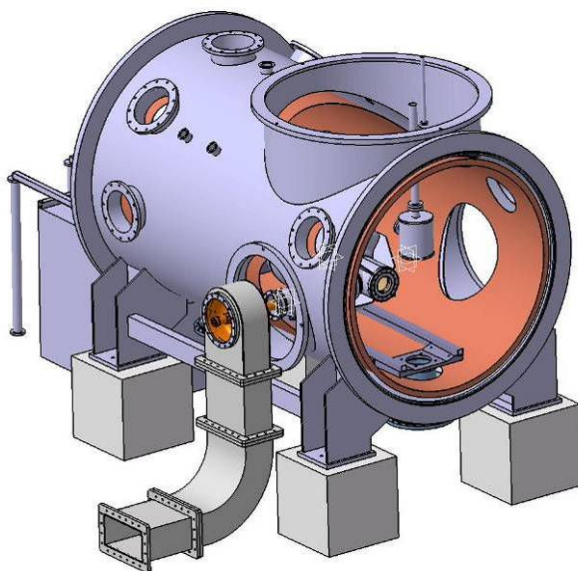


Figure JRA3.3.9: 3D model of the cavity/coupler assembly in CRYHOLAB.

#### *JRA3.3.2.6 RF source order and preparation (subtask 3.1.8)*

The 1MW klystron has been ordered to CPI (Communications & Power Industries) in August 2005, sixteen months being necessary for its realization. This klystron is derived from the VKP-7952B klystron of BNL (1MW CW at 700 MHz).

The 1MW peak circulator has been ordered in October, and should be delivered before June 2006. It will be, in a first time, tested at low power at the company (VSWR measurements at all the phases and matching conditions), and, in a second time, at Saclay at nominal power with the klystron. We keep the previous schedule (first quarter of 2007) for the acceptance test of all these power components.

#### *JRA3.3.2.7 Modulator preparation for the 700 MHz test stand (subtask 3.1.10)*

A klystron gun voltage below 95kV for reaching a output peak power of 1 MW was required in our technical specifications for the klystron. This is of major importance since the existing HV pulsed generator can then be used. However, modifications of this generator (HV power supply, water cooling of the oil tank, HV connectors, isolating frame) are needed in order to get the 10% duty cycle. The drawings of the modified HV modulator are in progress, and the order for the 110kV power supply is ready to be placed. Our goal is to realize all the modifications in the first semester of 2006, in order to have a HV generator fully tested and ready to be used for the end of the year 2006.

### **JRA3.3.3 FZJ Activities**

#### *JRA3.3.3.1 Test stand preparation (task 3.2.1)*

The test stand is prepared. It was tested successfully with measurements on superconducting HWR structures. The goal of this activity is reached and the activity is now closed.

### JRA3.3.3.2 Evaluation of 700 MHz resonator (task 3.2.2)

The weldings for this resonator were successfully completed. Helium leak test was successfully passed. Chemical treatment was performed at CEA Saclay. 104  $\mu\text{m}$  of Nb were removed. After final rinsing the cavity was closed with clean coupler and antenna and transferred back to Jülich. First cooldown and RF measurements at the test stand started in March 2005.



Figure JRA3.3.10: Niobium cavity mounted on the cryostat girder.

The result of the first measurement is displayed in Fig. JRA3.3.3.11. The measurement was limited by a cable failure, so the data shown are NOT limited by the cavity.

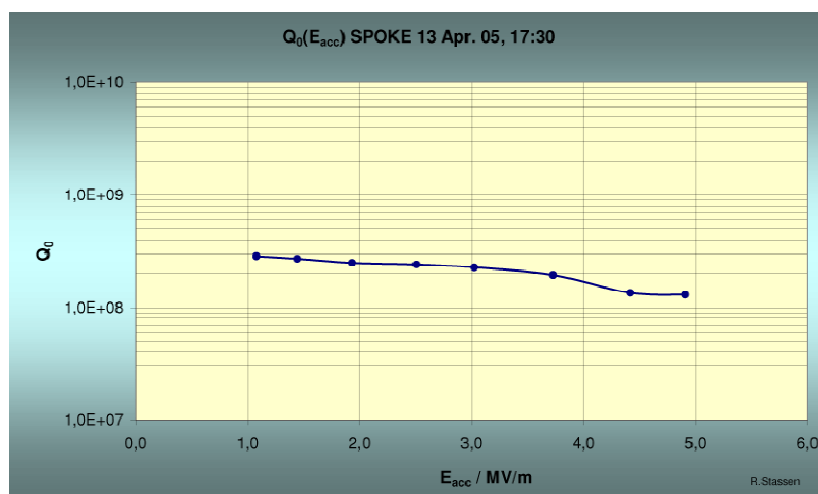


Figure JRA3.3.11: Q vs Eacc curve at 4 K (the accelerating field was limited by RF power).

The interim report on the cavity performance has been delivered as CARE/HIPPI Document-2005-004. Further measurements are planned for autumn 2005 to gain more knowledge on the cavity performance. Thus, it is suggested to extend this activity until 12/05.

### JRA3.3.3.3 RF design of 352 MHz multi-gap resonator (task 3.2.6)

The RF design of the 352 MHz resonator was frozen. It was decided to build the resonator without He cover for use in a bath cryostat. Calculations aiming at supplying sufficient rigidity to the structure and at the same time limiting the mechanical stress on the niobium to practical values are completed. The results have been summarized in a report. The Design Report has been finished and has been published in November 2005 as a HIPPI Document.

#### *JRA3.3.3.4 Final mechanical design of resonator (subtask 3.2.7)*

Drawings of the mechanical design of all resonator parts are finished (Fig. JRA3..3.12).

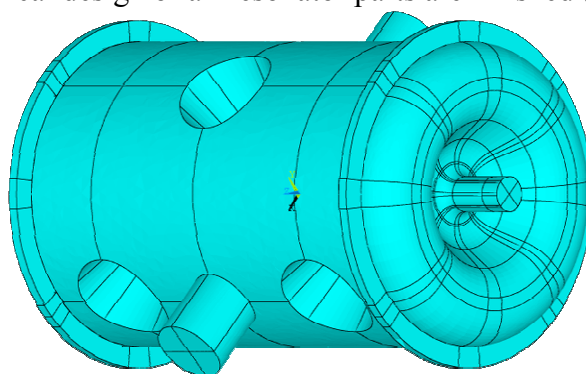


Figure JRA3.3.12: View of the 352 MHz triple spoke cavity without external stiffening.

As is shown in the Design Report for the 352 MHz triple spoke cavity additional stiffening may be necessary. Two approaches seem to be possible to be added to the closed cavity: (i) weld additional parts like indicated in Fig. 4.3.13 to the cavity or (ii) weld the rings onto the cavity and use a copper layer instead of the clamps on the endcaps (thickness in the order of 20 mm). Both options are currently pursued in parallel to ease timely manufacturing. For this purpose, additional design drawings for parts for cavity stiffening are being made. These parts can be mounted to the cavity after closing the bare cavity itself.

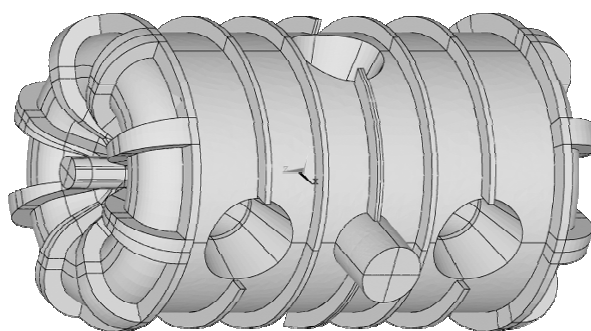


Figure JRA3.3.13: View of the 352 MHz triple spoke cavity with external stiffening.

#### *JRA3.3.3.5 Integration of coupler. Tuning options (subtask 3.2.8)*

The coupler is contributed by IPN-Orsay. Integration of the coupler is in progress.

Options for tuning under the existing boundary conditions are being evaluated. As is indicated in the Design Report for the 352 MHz triple spoke cavity the tuning is more favourable to be placed on the cylindrical part of the cavity.

#### *JRA3.3.3.6. Preparations for electron beam welding (subtask 3.2.9 – new sub task)*

The forming process for relevant parts of the cavity (e.g. end caps) has started using copper sheets. Ordered RRR Nb sheets arrived in the lab. Two big Nb-sheets for the cylindrical part of the cavity still wait to get their surface quality improved by the delivering company. This issue moving onto the critical path of the project. The mechanical design and fabrication of equipment for supporting and fixing the cavity parts during electron beam welding are progressing well.

In parallel, we are preparing with IPNO the test of the 352 MHz resonator. Planning for cryostat and power amplifier to be available for resonator test is progressing well. Power test will be limited by the available pulsed amplifier.



### JRA3.3.4 CNRS-Orsay Activities

#### JRA3.3.4.1 Evaluation of 352 MHz 2-gap prototypes (task 3.2.3)

Two main changes were decided on the second prototype (see Fig. 4.3.14):

1. A new stiffening system on each end-cup to sustain the external pressure of 1 bar while the cavity is under vacuum *without fixing* its beam tubes.
2. A new location of the RF port to avoid the extra-losses observed with the beta 0.35 spoke cavity. NB: the RF port diameter has also been changed (from  $\text{\O}30$  mm to  $\text{\O}56$  mm) to fit the power required for the EURISOL and EUROTRANS linacs (i.e. a peak power level of 15 kW in CW).

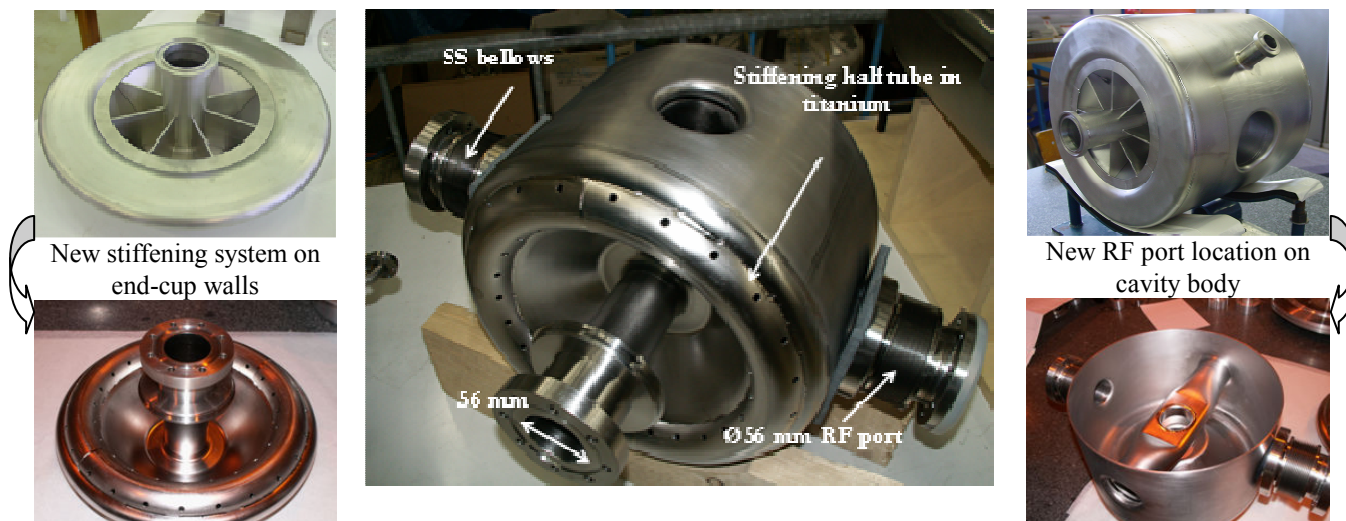


Figure. JRA3.3.14: Beta 0.15 spoke cavity.

The cavity has been fabricated by the CERCA Company. It has been delivered in December 2004 (without its Helium vessel) and firstly tested at ambient temperature.

During the test at 300 K, no leaks were detected and we have verified the good mechanical behaviour of the new stiffening system while the cavity was under vacuum load. The following table shows that the measurements of the displacements and the frequency shift were in good agreement with those expected. We did not observe any plastic deformation.



Mechanical parameters of the cavity (under vacuum load).

	Calculation		Measurement @ 300 K BC: beam tubes free
	BC: beam tubes free		
	Ansys*	Cosmos	
Maximum displacement of the beam tubes [mm]	0.14	0.18	0.17
Maximum Von Mises stress [MPa]	43.8	38.7	N/A
Frequency shift [kHz]	-378.7	N/A	-440

\*Calculations performed by E. Zaplatin (FZJ)

Then, we measured the thickness of the cavity walls (after the chemical treatment of about 140  $\mu\text{m}$ ) on 20 points of 16 azimuthal profiles. Figure 4.3.15 shows the mean value on a profile and one can notice that the thickness is locally near 2 mm on each end-cup (instead of 3 mm)! As observed during the tests, this thickness reduction had a big effect on the static Lorentz forces detuning factor.

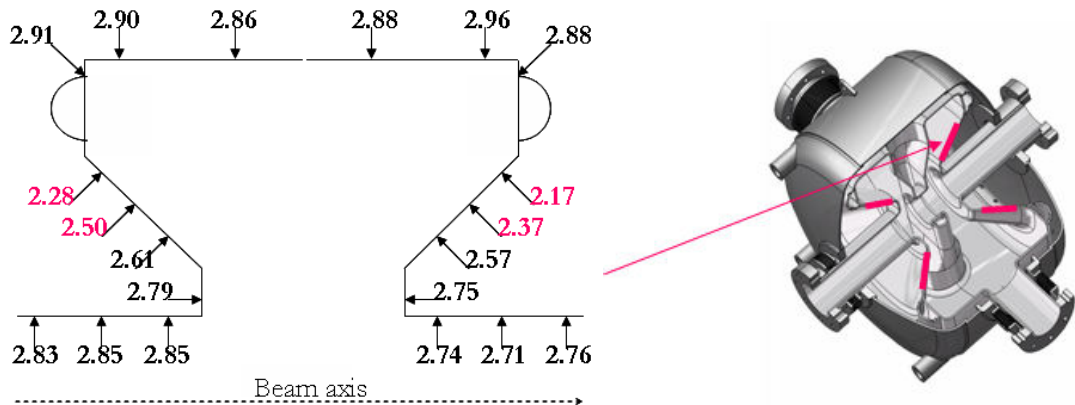


Figure JRA3.3.15: Mean value of the thickness along a profile.

The first cold test of the 352 MHz, beta 0.15, 2-gap spoke cavity was performed in April 2005. The preparation of the cavity has been done at CEA/Saclay:

- a chemical treatment (BCP) of about 140 $\mu\text{m}$
- followed by a 2-hour HPR processing at 80 bars through all ports.
- several hours of drying under laminar flow (no bake-out) followed by a final assembly in a class 100 clean room.

First test at 4.2 K needed a 2-hour conditioning process to reach 9.6 MV/m ( $\Leftrightarrow$  dissipated power inside the cavity:  $\sim 15$  W). The limitation was a quench (following curve). Two multipacting barriers were observed at 1.5 MV/m and around 8 MV/m but both processed within a few minutes. X-ray emission started from 4 MV/m during the first test then, nothing after that during the second and third tests. We also saw a quench during the test at 2 K at Eacc max = 10.5 MV/m ( $\Leftrightarrow$  dissipated power inside the cavity:  $\sim 8$  W). The same multipacting barrier was observed at 8 MV/m but without X-ray emission.

As the quench levels were the same, i.e. for  $B_{peak} \sim 70$  mT, one can suspect a big defect on the RF surface (around 100  $\mu\text{m}$  of diameter). So, we plan to remove 200  $\mu\text{m}$  more for the next test, hoping to take off this defect.

We also want to couple the cavity by the RF port (instead of the beam tubes as it was the case during this first test). We would like to validate the choice of the coupler location.

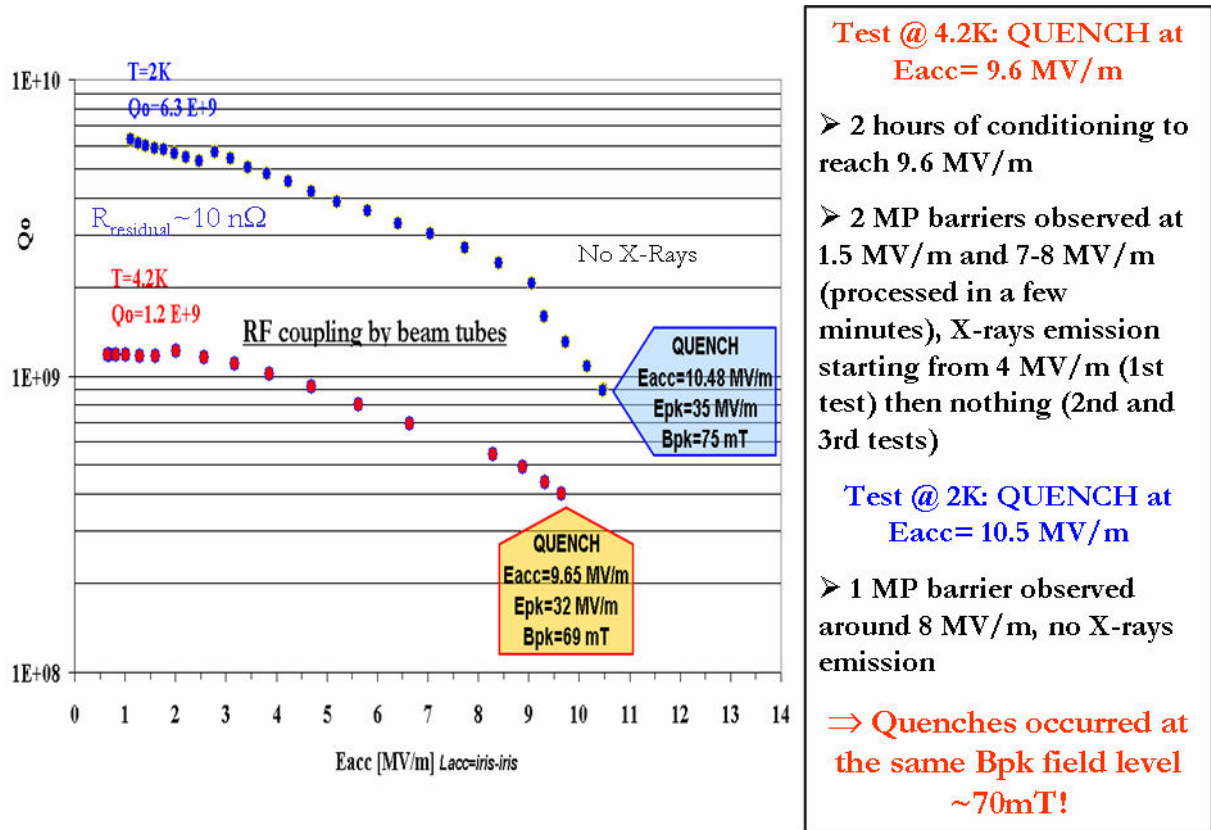


Figure JRA3.3.16: First cold tests results (2K and 4K) of the  $\beta_{0.15}$  2-gap spoke cavity.

The cavity was seated, inside the vertical cryostat, in a “beam tubes free” configuration (no external stiffening system was used like the one used for the beta 0.35 spoke cavity tests). The static Lorentz forces detuning factor was measured:  $K_{Lorentz\ measured} = -55$  and  $-47$  Hz/(MV/m)<sup>2</sup>. With his calculations, E. Zaplatin (FZJ) has shown the big effect of a thickness reduction on all spoke cavity walls (Fig. JRA3.3.17). One can see a good correlation with the calculated values for a cavity wall thickness between 2.5 and 2 mm. A new comparison will be done using the real thickness of the cavity to improve the calculated value.

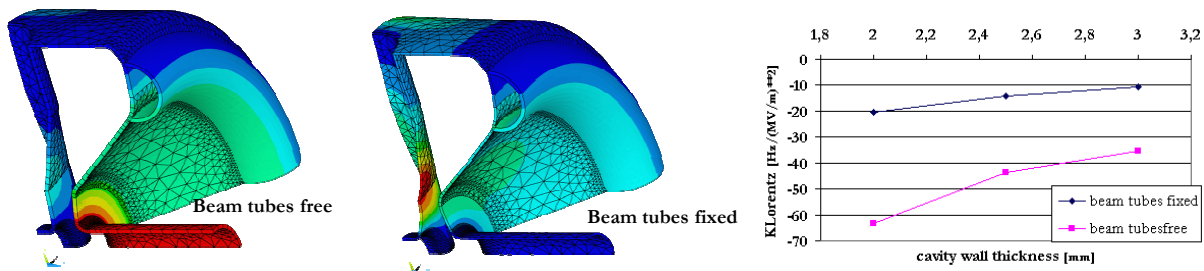


Figure JRA3.3.17: The static Lorentz detuning factor vs. the cavity wall thickness.

The next step will be to test this cavity in a more realistic “accelerator configuration”. So, we plan to test in 2006, the beta 0.15 spoke cavity with its power coupler in a horizontal cryostat.

For that purpose, we ordered, in October 2005 to the CERCA Company, the fabrication of the Stainless Steel Helium vessel. The delivery is foreseen in December 2005.

#### JRA3.3.4.2 Design of coupler prototype (task 3.2.4)

The study of the coupler prototype has progressed during the last months. Following a preliminary RF design study, detailed drawings of the mechanical components have started in March 2005. First detailed study was completed in June 2005 (see following figures).

A ceramic disk window assembly was designed with a simple impedance compensation scheme obtained by reducing the diameter of the inner conductor in the window area. Some cross-checks and fits with the cryomodule setup will allow very rapidly the procurement of this assembly.

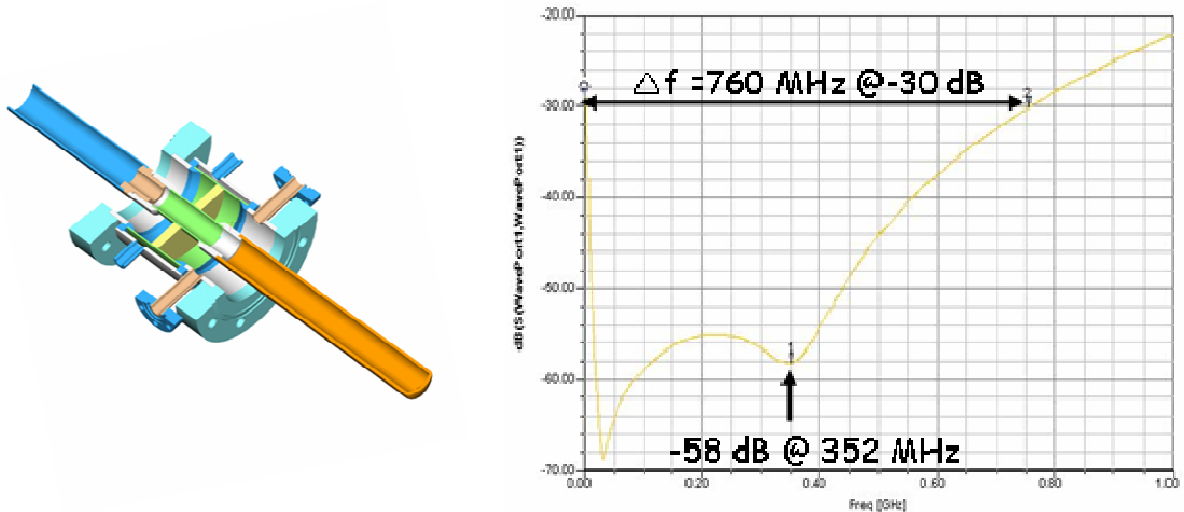


Figure JRA3.3.18: 3D drawing of the power coupler (left) and S<sub>11</sub> parameter magnitude vs. the frequency for the cylindrical window without chokes (right).

Presently, the main goal is to install the  $\beta 0.15$  spoke cavity with its coupler in a horizontal test cryostat. The horizontal cryomodule CM0 (old capture cryomodule designed and constructed by IPNO for the CEA MACSE superconducting electron accelerator project in the 1990 period) will be a quick and convenient set up for the tests: integration of the  $\beta 0.15$  spoke cavity and the prototype coupler in order to test them at high power levels (up to 20 kW in CW regime).

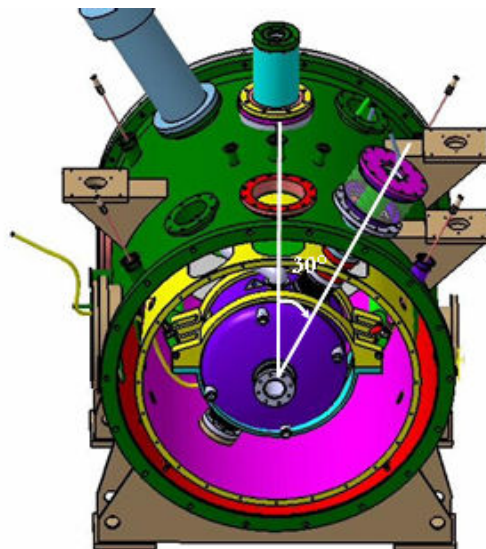


Figure JRA3.3.19: The beta 0.15 spoke cavity inside the horizontal cryostat CM0.

We are now finalizing the detail study of the CM0 structure modifications (i.e. for the vacuum vessel, the thermal shielding, the cryogenics pipes and valves...).

A rough schedule is presently considered:

- First tests at 4K and low power (i.e. 600W) *with the cavity only*: april 2006
- Test with the cavity *and* the coupler: foreseen in July/August 2006
- Test at higher power level (i.e. at least 5 kW): 2007 ... it depends of the funding

#### *JRA3.3.4.3 RF design of 352 MHz multigap spoke resonator (task 3.2.6)*

In the frame of the design study concerning the multigap spoke cavity proposed by the Jülich group, some cross-check calculations have been performed at IPN Orsay using CATIA and CASTEM codes. An interface has been developed to analyse and rearrange the CATIA meshing, and translate it into a specific CAST3M meshing.

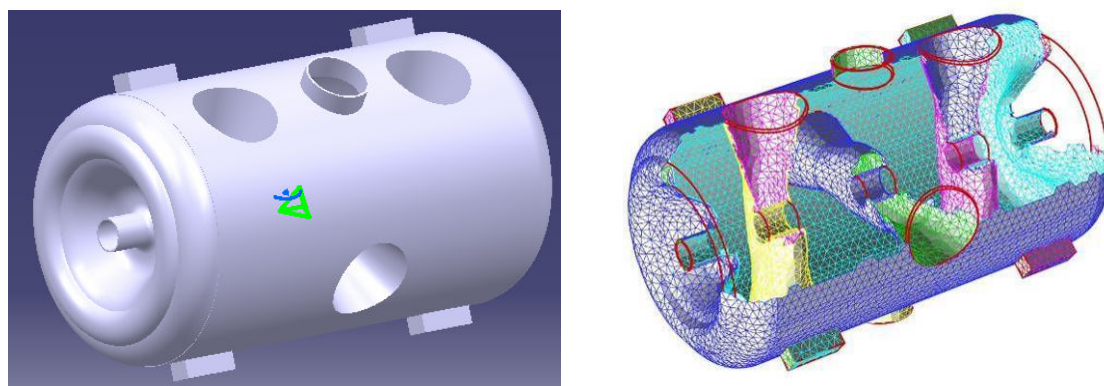


Figure JRA3.3.20: Multi-gaps spoke meshing for mechanical studies.

Different mechanical structure characteristics were evaluated:

- Static analysis: cavity deformation under vacuum conditions. Several fixing schemes of the cavity inside the helium tank were studied, along with the influence of the cavity wall thickness. The maximum stress peak was calculated: 15.3 MPa, and the maximum displacement of 0.072 mm, both results are very close to those obtained using ANSYS code.
- Dynamic analysis: the first eigen-modes were analyzed (138 ...460 Hz). The frequency of these modes is considerably raised by using the half-torus stiffeners located on both cavity end-plates. Here again the results were very close to those obtained with ANSYS.

#### JRA3.3.5 IAP-FU Activities

##### *JRA3.3.5.1 CH resonators (subtask 3.3)*

The development of the superconducting CH-prototype proceeded in three directions during the last year and can mainly be described by the following topics:

- 1) Study of the mechanical properties and vibrational states
- 2) RF measurements in the superconducting state
- 3) Conceptual studies of a tuning system

From the constructional point of view the CH-prototype has been stabilized with stiffener rings to avoid possible plastic deformations during the application of vacuum. The rings have been welded on the outer shell of the cavity as can be seen in the picture below. The following



vacuum test successfully demonstrated the absence of leaks and sufficient stability of the structure to keep the deformations in the elastic domain.

The electromagnetic field distribution has been measured and compared with results of the computer simulations done with the Microwave Studio® software. The field turned out to be flat and the similarity between experimental and simulation results is given to a very high degree.

During final preparation the cavity has been chemically treated with a procedure called Buffered Chemical Polishing (BCP) to remove about 0.1 mm of the inner surface. After the application of high pressure water rinsing in order to remove dust particles from the inner surface of the cavity, the RF couplers have been installed in a clean room. Now the cavity is ready for conditioning with high RF power at room temperature to reduce the possibility of multipacting barriers to occur.

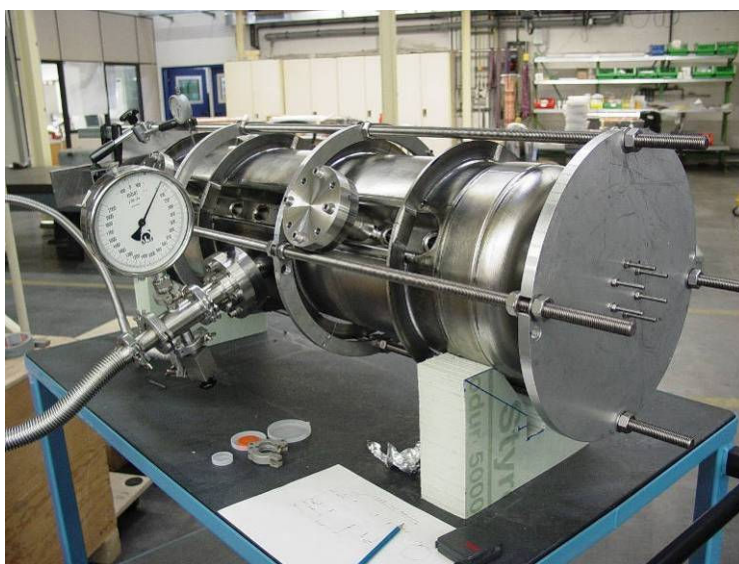


Figure JRA3.3.21: The CH-cavity during a vacuum test before the chemical treatment.

The mechanical analysis of the CH-cavity is necessary in order to obtain values for peak stresses, deflections and flange reaction forces under vacuum load at room temperature and low cryo-temperatures. An important part of the simulation is devoted to the determination of mechanical vibrational eigenmodes. Modes at lower eigenfrequencies are assumed to be excited by the vibrational background noise that cannot be avoided. The results presented here are obtained with the ANSYS® Multiphysics finite element software tool.

Two RF test series in the superconducting state have been performed at the new cryogenic RF laboratory that has been established at the University of Frankfurt. The cavity has been cooled down below the critical temperature in a vertical cryostat and the obtained results are presented within this report.

On the bases of the mechanical simulations performed a tuning system is proposed. A new cryomodule has recently been obtained, which offers the possibility to perform tests in a horizontal position in the future. The already existing tuning unit of this module has to be evaluated according to its usability and plans for the reconstruction have to be made.

Mechanical properties of the superconducting CH-prototype:

The analysis of the CH-cavity has been performed in order to calculate the maximum stresses, deflections and flange reaction forces under vacuum load at room temperature as well as under cryo-temperature conditions. The whole CH-cavity, including the stiffening rings, has been made of niobium (RRR=250) sheets with a thickness of 2 mm. The supporting frame (stabilizing end plates and cross connections) is made of stainless steel and aluminum. Symmetric boundary conditions have been applied to reduce the CPU time and increase the computability of the problem. The maximum displacement of 2.72 mm occurs at the steel cross connection as can be seen in the graphics below. The maximum von Mises stress with a value of about 273 MPa only occurs at the junction of cross connections and aluminium end plates (Fig. JRA3.3.22), which are both uncritical for the cavity. The higher values at the end plate of the resonator are artificial due to the chosen ANSYS fixed points in space.

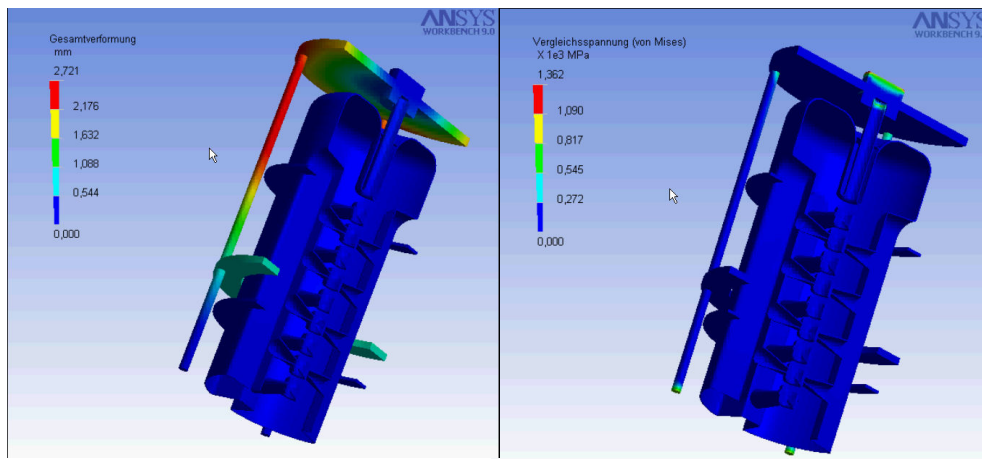


Figure JRA3.3.22: Total deformation of the sc CH-cavity (left) and maximum von Mises stress.

For the simulation of the vibrational eigenmodes of the system we take a connection between the outer drift tubes and the corpus of the cavity into account, which has not been implemented in the model presented in the last report. Next figure shows a picture of this detail, which has a strong influence on the characteristics of the vibrational modes at low frequencies. In addition new symmetry boundary conditions have been applied, which make it now possible to describe the whole length of the cavity. The advantage of this description is that a variation of the geometry of the inner structure of the cavity along the longitudinal axis can be taken into account in the future.



Figure JRA3.3.23: Connection between outer drift tube and corpus of the cavity.

The ends of the drift tubes are fixed in space during the simulation. The vibrational modes in the area of frequencies  $< 100$  Hz should be avoided (coupling to background noise and



vibrations at the power supply frequency of 50 Hz). The lowest vibrational modes of the CH-cavity have been found to have eigen-frequencies of 87, 247 and 405 Hz.

In the following figures, 3D representations of the first and second vibrational modes are shown. The displacements are up scaled to get an impression of the motion. The first mode has no transverse displacement and shows a movement along the longitudinal axis only. The cavity is assumed to be fixed in a horizontal position under the impact of gravity. The second mode shows transverse displacement.

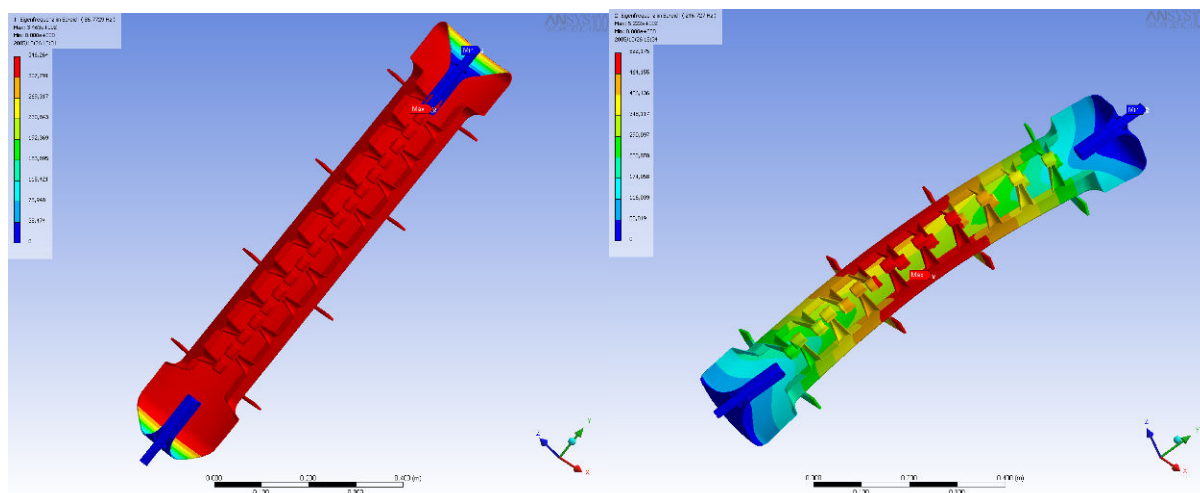


Figure JRA3.3.24: Vibrational modes: first mode at 87 Hz (left) and second mode at 247 Hz (right).

RF measurements in the superconducting state:

To test the CH-cavity at 4K a new cryogenic RF laboratory has been established in Frankfurt. It is equipped with:

- Class 10000 clean room
- Class 100 laminar flow box
- 3 m vertical bath cryostat
- Magnetic shielding
- 2 transport dewars for liquid helium
- 2 kW RF amplifier
- 50 W amplifier
- Helium recovery system
- RF control system
- Temperature measurement system

Next figure presents the CH-prototype with the position of 8 temperature sensors before mounting in the cryostat. The cavity has been pre-cooled with liquid nitrogen und than cooled down with liquid helium below the critical temperature. The cavity reached the superconducting state without problem.

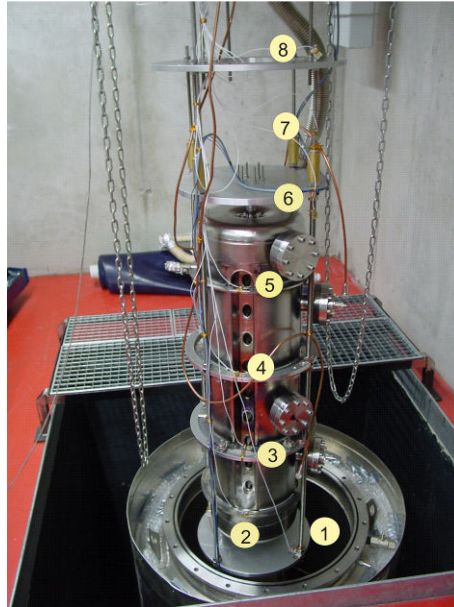


Figure JRA3.3.25: sc CH-prototype with 8 temperature sensors ready for the first cold test.

At a field level of about 40 kV/m a first multipacting barrier occurred. But this barrier could be processed within one hour without problems. The experience with a large number of existing H-type structures showed that there is in general no problem with multipacting. As expected multipacting is not a severe problem for superconducting CH-structures too.

The control system which has been developed in Frankfurt worked very well. During the second day of the first cold test a maximum accelerating voltage (including the transit time factor) of about 3.54 MV has been reached in cw operation. The limitation in the test was given by the effect of field emission at electric surface peak fields of more than 20 MV/m (see next curves). The maximum voltage corresponds to an electric surface peak field of 24 MV/m and a maximum magnetic peak field of 26 mT. The design gradient of the prototype cavity (3.2 MV/m) has been exceeded. The reached gradient with respect to the full cavity length was 3.4 MV/m and with respect to a length of  $n \cdot \beta \lambda / 2 = 9.5 \beta \lambda$  was 4.45 MV/m. In pulsed operation these fields have been exceeded.

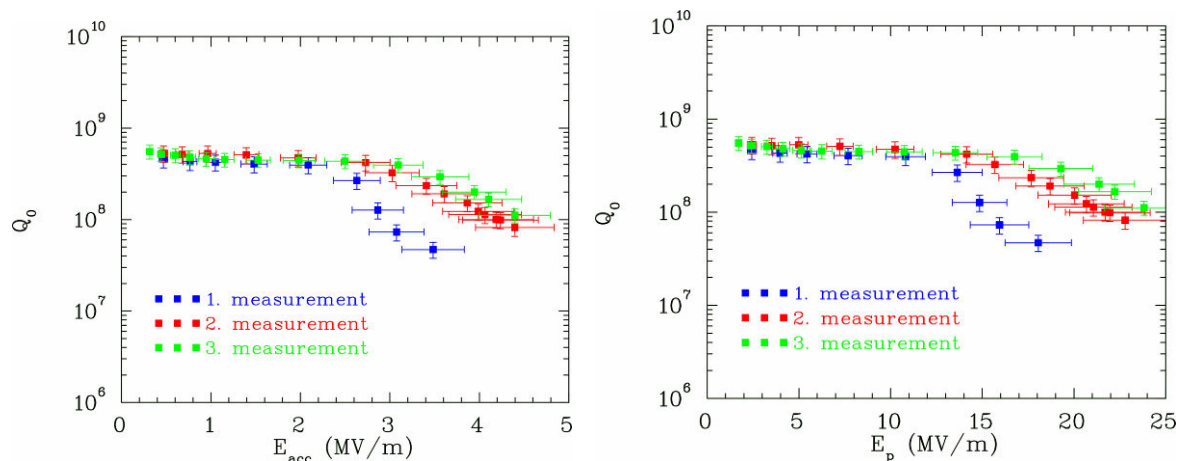


Figure JRA3.3.26: cw measurements at 4.2K of the sc CH cavity:  
Q vs accelerating gradient with  $L_{acc} = 9.5 \beta \lambda$  (left) and Q vs peak surface field (right).

The Q-value decreases typically for superconducting structures due to non Ohmic losses like field emission. The Q-value at low field was  $5e8$  which corresponds to a total surface

resistance of  $110 \text{ n}\Omega$ . The BSC value at 4.2K and the design frequency is  $41 \text{ n}\Omega$ . Together with an additional resistance due to trapped magnetic flux of  $4 \text{ n}\Omega$ , the surface residual resistance is  $65 \text{ n}\Omega$ . The dissipated power at the design gradient was approximately 15W.

### ***JRA3.3.5.2 Conceptual study of tuning system (subtask 3.3.1)***

Considering all the circumstances, we favor the blade tuner designed by INFN (see the report for subtask 3.1.2). Due to the slim frame around the helium vessel and the position of the stepping motor above or below the cavity, the needed longitudinal space between two CH-resonators is very small. This allows a sequence of s.c. resonators with only a narrow space between them and no additional focusing element in the intertank sections are required.

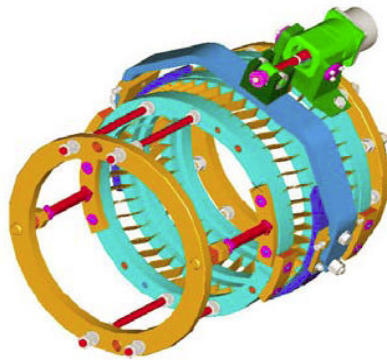


Figure JRA3.3.27: Detailed 3D-drawing of a blade tuner frame with piezo-assisted tuner.

First ANSYS® calculations of the maximum allowable slow-tuner force under 2 atm. pressure at 4.2 K and a mechanical rigidity of 2 mm thin bulk niobium sheets of the s.c. CH-prototype without an additional supporting frame showed, that not more than 400 kg traction power is needed to guarantee a 2 mm tuner stroke in both directions. Figures JRA3.3.28 and JRA3.3.29 show the simulated ANSYS® safety-factor-distribution of maximum von Mises stress of the sc. CH-cavity with  $\pm 2 \text{ mm}$  end drift tube displacement applied by an external force driven at the tank end drift-tube.

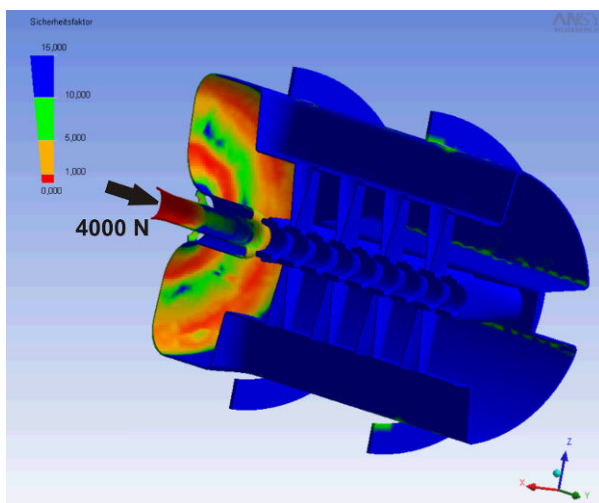


Figure JRA3.3.28: ANSYS® calculated safety-factor-distribution of maximum stress of Mises of the sc. CH-prototype under 2 atm. at 4.2 K and an external tuner squeezing force of + 400 kg.

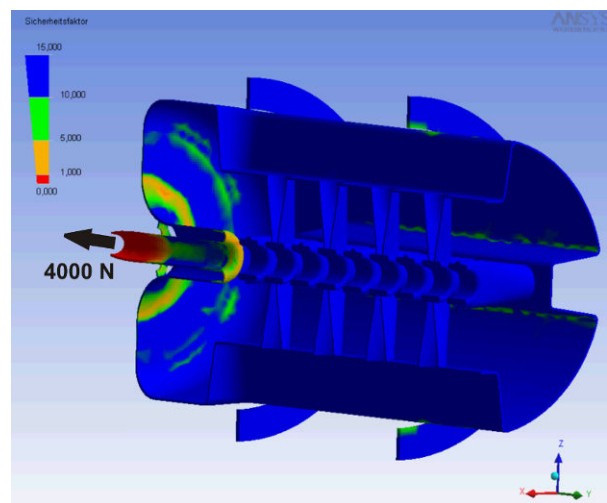


Figure JRA3.3.29: ANSYS® calculated safety-factor-distribution of maximum stress of Mises of the sc. CH-prototype under 2 atm. at 4.2 K and an external tuner squeezing force of + 400 kg.

In addition with the MWS® calculated tuner sensitivity of 0.194 kHz/ $\mu\text{m}$  leads to the following proposed slow-tuner parameters:

Tuner stroke:	$\pm 2$ mm
material:	stainless steel
maximum traction power:	400 kg
maximum reaction time:	1 sec
minimal tuning range:	0.388 MHz

The first planned application of the new s.c CH-resonators is in cw mode, to overcome the microphonics problem. Therefore in a first technical design study a fast-tuner is not foreseen. But in order to have a wider spectrum of possible future applications the next design level will include a piezo fast-tuner. For testing purposes a cryostat shown in Fig. 4.3.30 has been obtained, which offers the possibility to operate in horizontal position. The thermal shield is cooled by liquid nitrogen. On one end of the module a tuning unit is placed. The cold mass of the cryostat is rather short for our purposes, but it could re-arrange in order to incorporate the CH-cavity. With this cryostat, first experimental tuning results could be obtained.



Figure JRA3.3.30. Cryomodule with tuning possibility for operation in horizontal position

### JRA3.3.6 Overall Progress of Work Package 3

The following table highlights the progress of work planned in the year 2005 for the Work Package WP3 by listing the lowest level subtasks of the HIPPI detailed implementation plan

WP3	Title	Original begin date	Original end date	Estimated Status	Revised end date
<b>3.1</b>	<b>Elliptical cavities</b>				
3.1.1	Cavity A vertical tests	jan. 2004	dec. 2004	Done	
3.1.2	Tuner design	jul. 2004	dec. 2005	90%	
3.1.3	Integration of piezo design	jul. 2004	dec. 2005	80%	
3.1.4	Tuner construction and testing	jan. 2006	Jun. 2006		
3.1.5	Design cavity B	jul. 2004	Oct. 2005	Done	
3.1.6	Construction cavity B	11 / 2005	Jun. 2006	0%	
3.1.7	Power coupler design & engineering	jan. 2005	Apr. 2006	60%	
3.1.9	RF coupler construction	jan. 2006	Oct. 2006		
3.1.8	RF source order and preparation	jul. 2004	Sept. 2006	50%	
3.1.10	Modulator preparation for test stand	jan. 2005	May 2006	50%	Sept. 2006
<b>3.2</b>	<b>Spoke cavities</b>				
3.2.1	Test stand preparation at FZJ	apr. 2004	Aug. 2004	Done	
3.2.2	Evaluation of 700 MHz prototype	sept. 2004	sept. 2005	90 %	
3.2.3	Evaluation of 352 MHz 2 gaps-proto	jun. 2004	jun. 2005	Done	
3.2.4	Design of coupler prototype	jan. 2004	dec. 2005	80 %	
3.2.5	Realization of coupler prototype	jan. 2006	jun. 2006		
3.2.6	RF design of 352 MHz multigaps-res.	jan. 2004	apr. 2005	Done	
3.2.7	Final mechanical design of resonator	05 / 2005	jun. 2005	Done	
3.2.8	Integration of coupler. Tuning options	jul. 2005	jun. 2006	30 %	
3.2.9	Preparations for electron beam welding	jul. 2005	Mar. 2006	40 %	
<b>3.3</b>	<b>CH resonators</b>				
3.3.1	Design of tuning system	jan. 2004	jun. 2006	70 %	

### JRA3.4 Work Package 4: Beam Chopping

#### JRA3.4.1 CERN Activities

The web-site, <http://lombarda.home.cern.ch/lombarda/WP4/WP4main.htm>, is used for exchanging useful information within the work-package. It contains the link to the presentations of the work-package yearly meetings.

Also during the year 2005 the work of WP4 is progressing steadily, notwithstanding some difficulties at CERN due to lack of drawing office support (low priority with respect to other projects).

The annual meeting of Work Package 4 was hosted by the CCLRC Rutherford Laboratories at the Cosener's House. It was held during 3 days (13-15 April) in conjunction with WP5. Informations about the meeting, including links to all the presentations, can be consulted at <http://conftest.isis.rl.ac.uk/Programme/wp4/>.

This joint event with WP5 was extremely beneficial: it gave the occasion to chopper hardware specialists and beam dynamics experts to exchange ideas and concerns. In particular the beam dynamics in the chopper line was analyzed in the wider context of the whole acceleration system till 200 MeV, as recommended by the ESAC advisory committee. Progress along those lines (simulating the effect of the chopper line much further down the line) is evident. Efficient collaboration in this working package was acknowledged during HIPPI05. The CERN chopper line has also been chosen as a candidate for a test benchmarking in WP5.

The goals of the WP4 meeting were the following:

- Status of the foreseen chopper performance,
- Discussion of the possibility to test the RAL chopper or some of its components on the 3 MeV test stand to be commissioned at CERN in 2007-2008.

The results of the first goal are summarized in Table JRA3.4. Details are given in the following two dedicated sections.

For the second goal, the conclusion was that an engineering design of the RAL chopper line should be completed beforehand. The interest of a partial test of one of the chopper line components was also debated, taking into account the unavoidable resources it would drain.

Table JRA3.4: Chopper characteristics

	Chopper A (CERN)	Chopper B (RAL)	
	Fast	Fast	Slow†
Rise/fall time	< 2 nsec	≤ 2 nsec	≤ 15 ns
Max. rep rate	50 MHz	2.6 MHz	1.3 MHz
Max. voltage/target	250 V/500V	1400V / 2200V	≤ 6kV
Flexibility	Min 3 pulses	7 – 15 ns	200 ns – 100 us
Chopping effectiveness (calculated)	99.7%	99.0 %	
Emittance growth of the un-chopped beam	8%	8% (New 3 MeV MEBT design)‡	

† Simulation only. ‡ Effect of residual chopper fields not included

#### **CERN:**

The advancement of the CERN chopper structure A has followed a somewhat different track than the one foreseen in the planning originally proposed, in order to cope with the delays generated by the overload of the CERN mechanical workshop. In particular, it has been decided, in agreement with the HIPPI Coordinators, to pass over the phases of pre-prototyping (tasks 4.1.1 and 4.1.2) and to go directly to the assembly of the full scale prototype. This change does not jeopardize the validation of chopper A, as the difference between pre-prototyping and prototyping was only in the mechanical configuration of the chopper and not in its core constituents. As a consequence, the milestones 4.1.1 and 4.1.2 apply now to task 4.1.3 and are therefore delayed by one year.



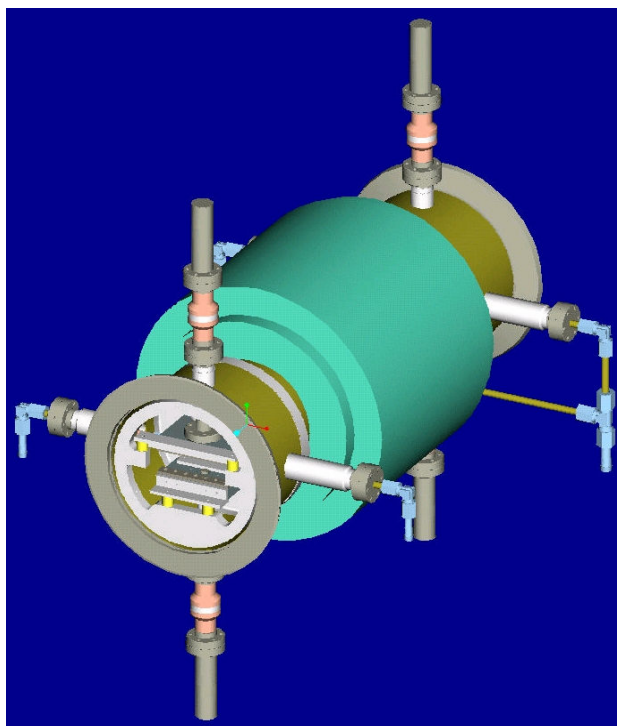


Figure JRA3.4.1 : Chopper system A housed inside a quadrupole.

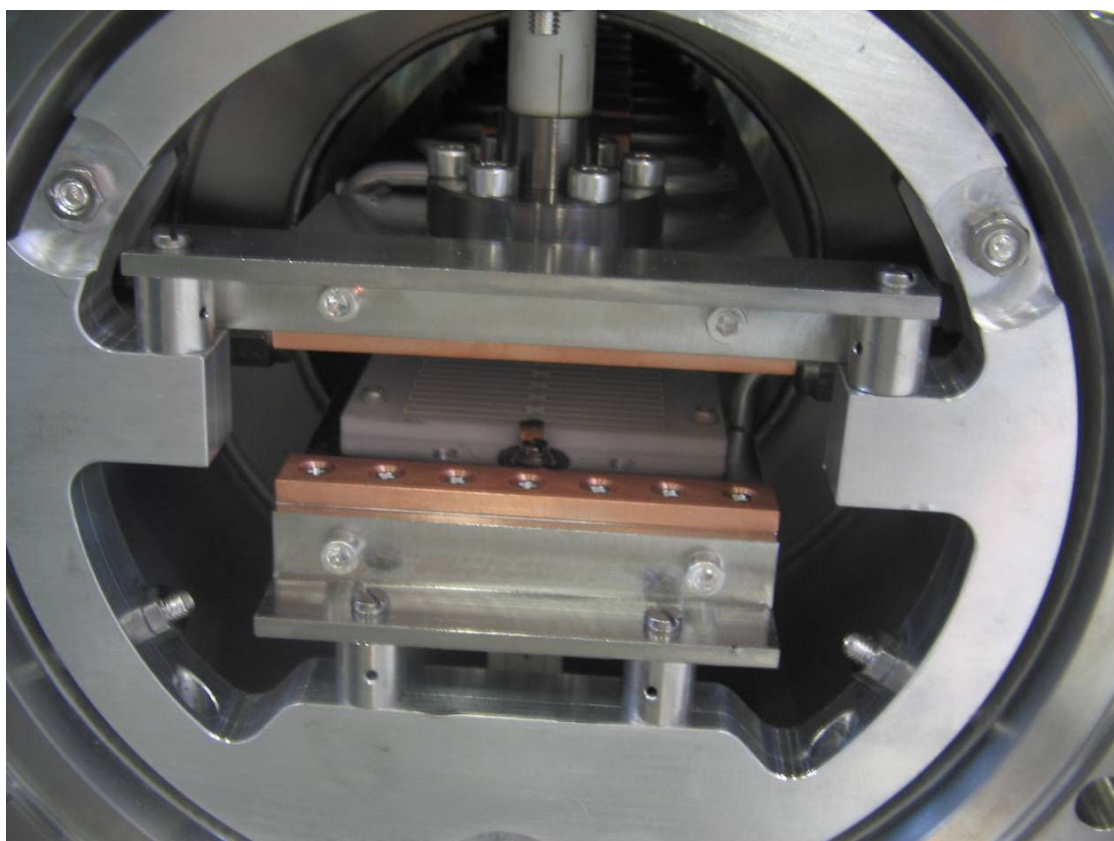


Figure JRA3.4.2 : Chopper plates manufactured at CERN, mounted in the quadrupole. The meander structure is clearly visible on the bottom plate.

*JRA3.4.1.1 Chopper structure (task 4.1.1)*

1. All the components have been assembled. They have been cleaned according to the CERN ultra high vacuum cleaning procedure. The quadrupole into which the chopper is assembled has been refurbished and has been electrically tested. The next steps are a

vacuum test and electrical tests. Should the vacuum test not be successful for the expected vacuum of  $10^{-8}$  torr, a bake-out at 150 degrees will be performed before the electrical tests. A mechanical drawing of the chopper housed inside the quadrupole can be seen in Fig.JRA3.4.1 and a picture of the chopper plates can be seen in Fig.JRA3.4.2. A commercial alternative (KYOCERA, Japan) has been found for the manufacturing of the chopper plates. It will be used for the second chopper structure if economically advantageous.

2. Chopper driver (subtask 4.1.3): The chopper driver approach which was adopted initially has been completely revised and solid-state MOSFET instead of tube amplifiers are now being developed. Preliminary results were encouraging (see table) and this new system should allow for a higher voltage than the initial target of 500 Volts per plate. After few months of testing the new system based on solid-state MOSFET became the mainline for chopper A. The ripple has been reduced to 3 percent peak-to-peak and beam dynamics study confirmed that this value is acceptable as the emittance growth induced in the transmitted is below few percent. A complete report on the chopper driver for chopper A has been published as CARE/HIPPI Note. This document constitutes an intermediate activity report.
3. Dump (subtask 4.2.1): the mechanical drawings of the dump were finished. A cut away can be seen in Fig. JRA3.4.3. Material as been procured and fabrication has started.

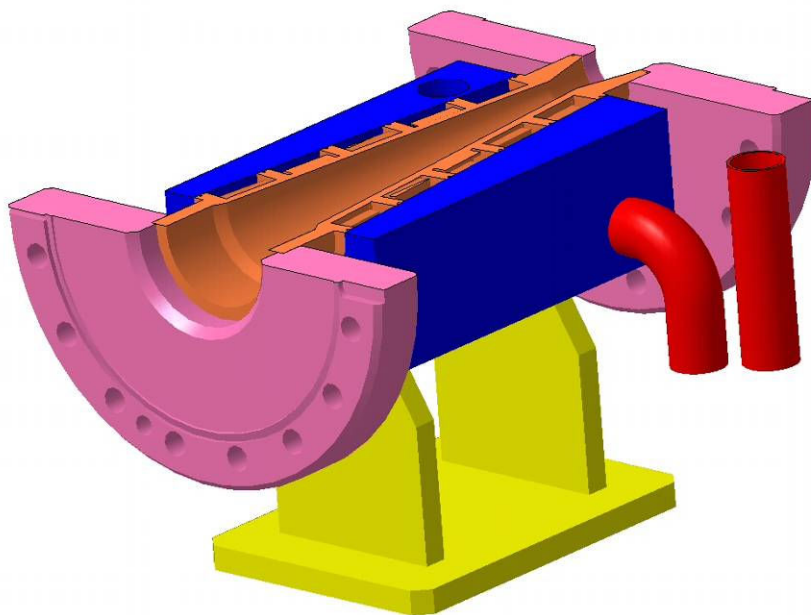


Figure JRA3.4.3: Cut away of the dump for the 3 MeV test stand: in blue the 304L stainless steel solid body; in orange the Glidcop® Al60 LOX core, where the beam is dumped

4. Beam dynamics studies, including matching to the subsequent possible accelerator have continued and the interface between the chopper line and the Drift Tube Linac is defined. The enveloped for the beam transmitted to the DTL and the chopped beam are shown in Fig.JRA3.4.4, and the losses in Fig.JRA3.4.5.

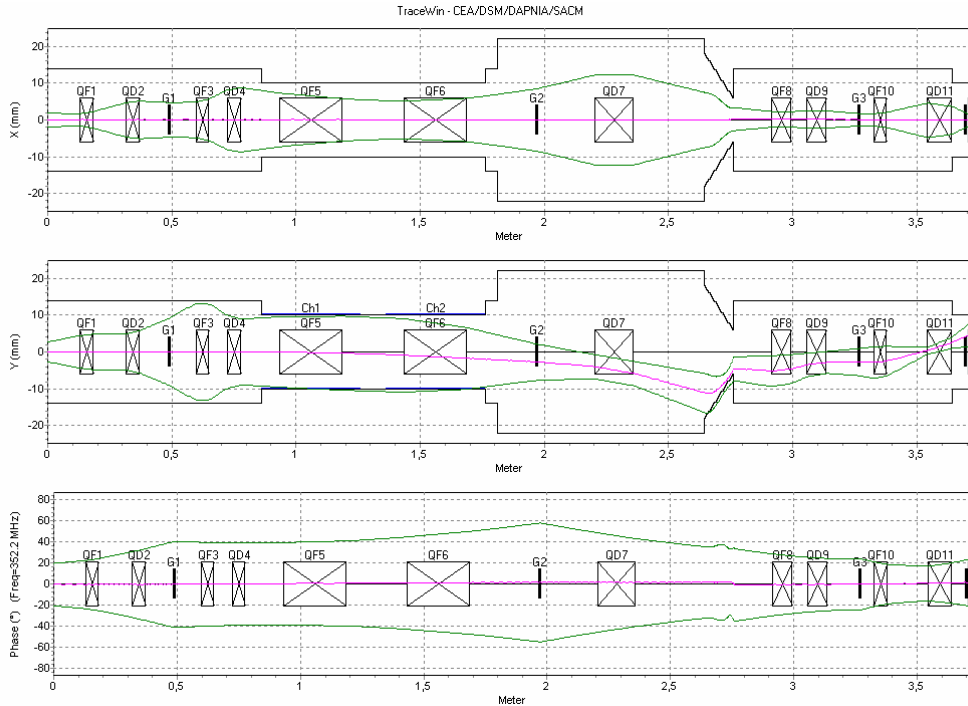


Figure JRA3.4.4: Beam envelopes in the chopper line. From top to bottom : 1) 1 transverse envelope for the beam matched to the subsequent drift tube linac, 2) transverse envelope of the chopped beam terminating on the dump and 3) longitudinal envelope at 352MHz for the matched beam.

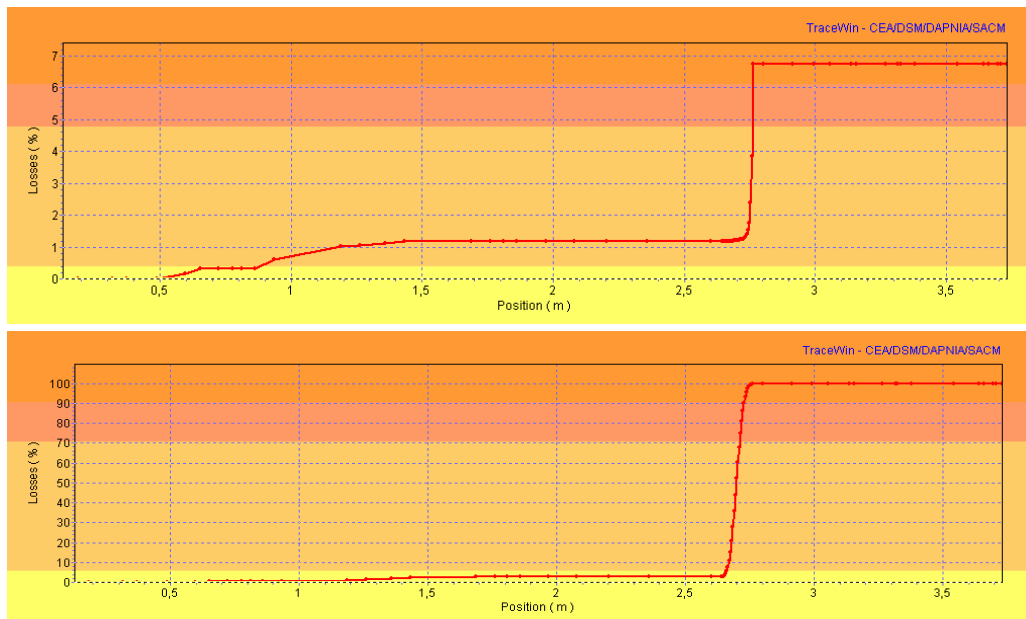


Figure JRA3.4.5: Losses in the chopper line for the transmitted (top) and chopped beam. It can be noticed that 0.3 percent of the chopped beam is not intercepted by the dump.

### JRA3.4.2 CCLRC-RAL Activities

#### *Chopper line redesign*

Triggered by the re-definition of the RFQ frequency (changed from 280 to 324 MHz), and energy (increased from 2.5 to 3 MeV), the beam dynamics of the RAL chopper line has been completely reviewed. In particular the FODO-type optics (similar to CERN's) design has the

positive consequence of lowering the required ‘slow’ transition chopper voltage from  $\sim 6.0$  to  $\sim 2.0$  kV, and providing a separate, dedicated beam dump.

Besides the original scheme for the RAL Front End Test Stand chopper line, initially modelled on the ESS design, has been recently revisited with the addition of dedicated beam dump(s), designed to take the full beam power, and a general relaxation of the parameters for all elements (apertures, distances, voltages etc). As a consequence, it has been possible to raise the MEBT energy from 2.5 to 3 MeV.

Work has been progressing on beam-dynamics simulations using a combination of the IMPACT, MaryLie/IMPACT and PATH codes. The line design is also being optimised using a generic algorithm running IMPACT on a Linux cluster.

Nominal beam tracking losses are compared for different beam distributions, giving statistical differences of the order of a few % and thus making variable dump and plate apertures strongly recommended in the real setup. Deflection occurs in the horizontal plane and beam survival is being studied as a function of the plate voltage in an attempt to minimise any partial chopping.

Two design options are currently being explored and optimised: a fast chopper/dump/slow chopper/dump scheme and a fast chopper/slow chopper/dump scheme. The first option would present a symmetrical layout where the two choppers would work independently of each other, while the second scheme would require a closer synergy of the two in kicking the beam to the dump. Performances are being compared in terms of nominal beam transmission through the line and chopping efficiency, in order to find the best compromise between reducing the voltage requirements on the chopper plates (ideally below 2kV) for easier and less costly engineering while at the same time limiting the amount of partially chopped beam surviving in the pipe to within a few tenths of a percent.

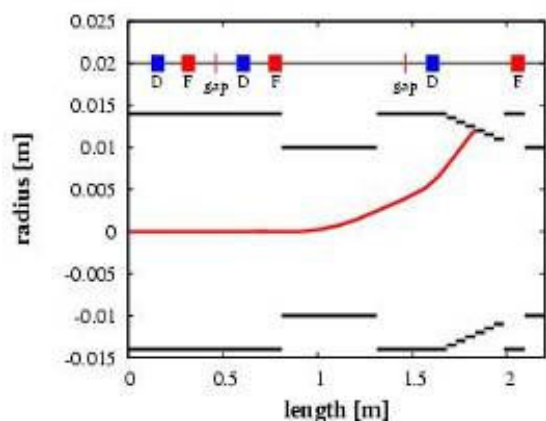


Figure JRA3.4.6: Deflection of the beam centroid (option 1)

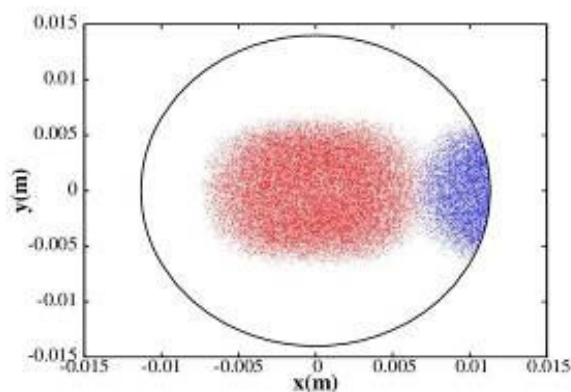


Figure JRA3.4.7: Beam separation at the centre of the dump (red=nominal beam, blue=deflected beam)

#### *Pulse generator development*

Testing, of the ‘slow’ pulse generator system has been delayed. The module designs are based on a standard ‘euro-cassette’ rack mounting format, and were designed at RAL in a 3D CAD environment. Over 100 2D detail drawings, based on the 3D designs, were produced by a contractor, and checked at RAL. During the period March – May 2005, the module components were manufactured by a contractor, and were received at RAL during the first week of June. The proposed ‘slow’ chopper structure will consist of eight electrode pairs, close coupled to a ‘phased array’ of eight SPG pairs as shown in Fig.JRA3.4.8.

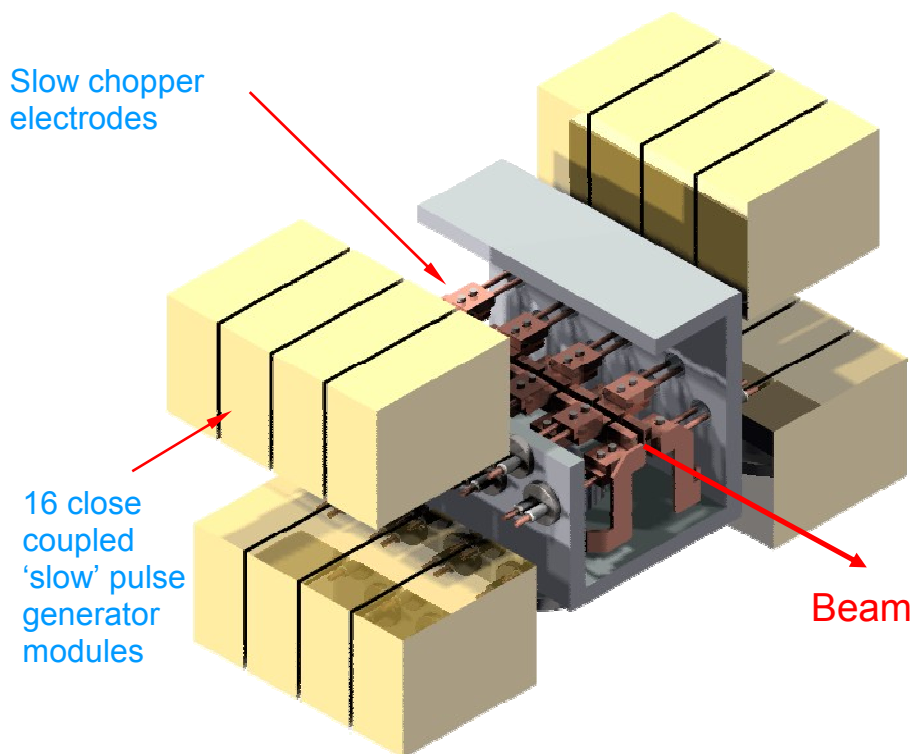


Figure JRA3.4.8: “ESS” slow chopper structure with SPG’s.

Pre-prototype testing is planned on a representative configuration of two adjacent SPG pairs. The four channel pre-prototype SPG system will initially be fitted with the ‘off the shelf’ switch modules, and tested at the maximum PRF of 0.1 MHz with a burst duration of 10 ms at a 50 Hz burst PRF. These high duty cycle tests should provide valuable information on switch reliability, cooling efficiency, and most importantly, on the effect of switch to switch coupling capacitance.

The intermediate report, representing a milestone, has been delivered in July 05.

Testing of the ‘Kentech’ fast pulse generator cards, fitted with an upgraded ferrite material, has resulted in a successful outcome. Phase 1 and 2 cards are now fitted with the upgraded material, and the ESS pulse droop specification has subsequently been met. This system is now available at RAL for testing slow wave structures, with dual polarity pulses of up to 1.4 kV in amplitude.

#### JRA3.4.3 Overall Progress of Work Package 4

The following table highlights the progress of work planned in the year 2005 for the Work Package WP4 by listing the lowest level subtasks of the HIPPI detailed implementation plan.

WP4	Title	Original begin date	Original end date	Estimated Status	Revised end date
4.1	<b>Chopper structure A (CERN)</b>				
4.1.1	Pre-prototype construction	Jan. 2004	Jun. 2004	Finished	Jun. 2005
4.1.2	Pre-prototype testing	Jul. 2004	Nov. 2004	Combined with task 4.1.5	Dec. 2005
4.1.3	Driver construction & testing	Jan. 2004	Dec. 2005	80 %	
4.1.4	Full scale prototype design	Jan. 2005	Jun. 2005	Finished	
4.1.5	Full scale prototype construction	Jan. 2005	Dec. 2005	90%	



4.2	<b>Chopper line (CERN).</b>				
4.2.1	Dump design	Jan. 2004	Jun. 2004	Finished	
4.2.2	Dump construction	Jan. 2005	Jun. 2005	20%	Dec. 2005
4.3	<b>Chopper structure B (RAL)</b>				
4.3.1	Pre-prototype design and test	Jan. 2004	Jun. 2005	Finished	
4.3.2	Prototype design	Jan. 2005	Dec. 2005	40 %	

### JRA3.5 Work Package 5: Beam Dynamics

#### JRA3.5.1 Joint Code Benchmarking Project

In the framework of the code benchmarking subtask in WP5 the 3D linac code comparison and benchmarking program has been continued. Following the static comparisons reported about in 2004, the five codes employed so far IMPACT, DYNAMION, PATH, PARMILA and HALODYN have now been used to study full tracking in the UNILAC drift tube linac (tank 1-4). While excellent agreement was found for the zero-current case, there are still discrepancies with space charge, possibly also due to different matching, which need to be resolved. Work about this is in progress. Details about the code benchmarking project: [http://www-linux.gsi.de/franchi/HIPPI/code\\_benchmarking.html](http://www-linux.gsi.de/franchi/HIPPI/code_benchmarking.html).

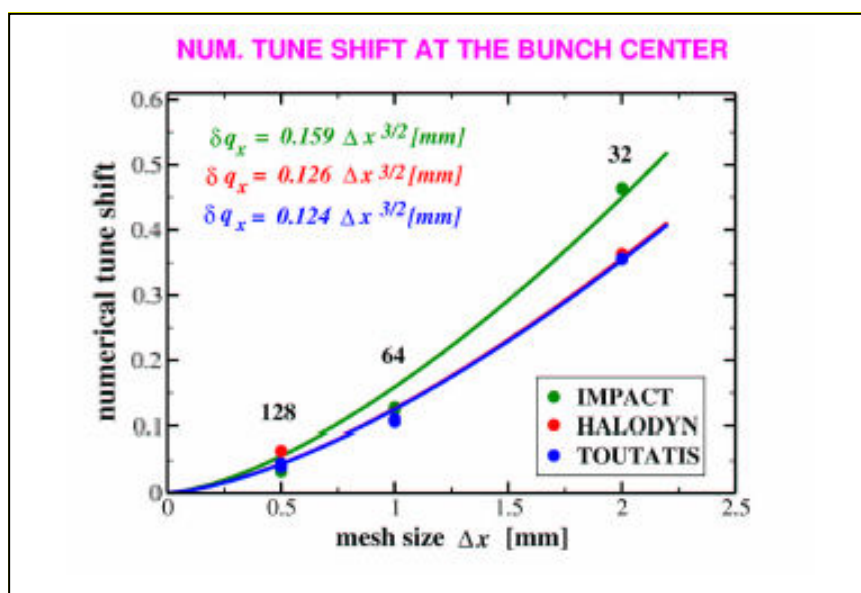


Figure JRA3.5.1: Numerical tune shift (at bunch center) generated by different codes and for three different mesh resolutions (grids with 32, 64 and 128 cells). Codes behave similar and suggest a "universal" dependence on mesh size  $\sim \Delta x^{3/2}$ .

#### JRA3.5.2 CEA Activities

##### JRA3.5.2.1 ECR source modeling

The ECR simulation development has been continuing during 2005. A bibliography phase has been restarted. Similar approaches, compared to the selected one by the Saclay team, have been found in the literature. They will feed the development process and the results will be used for cross-checks. A 2D (R-Z) Finite Difference Time Domain solver to simulate the wave propagation in the ECR domain has been implemented to speed up the computations in case of axisymmetrical ECR sources.



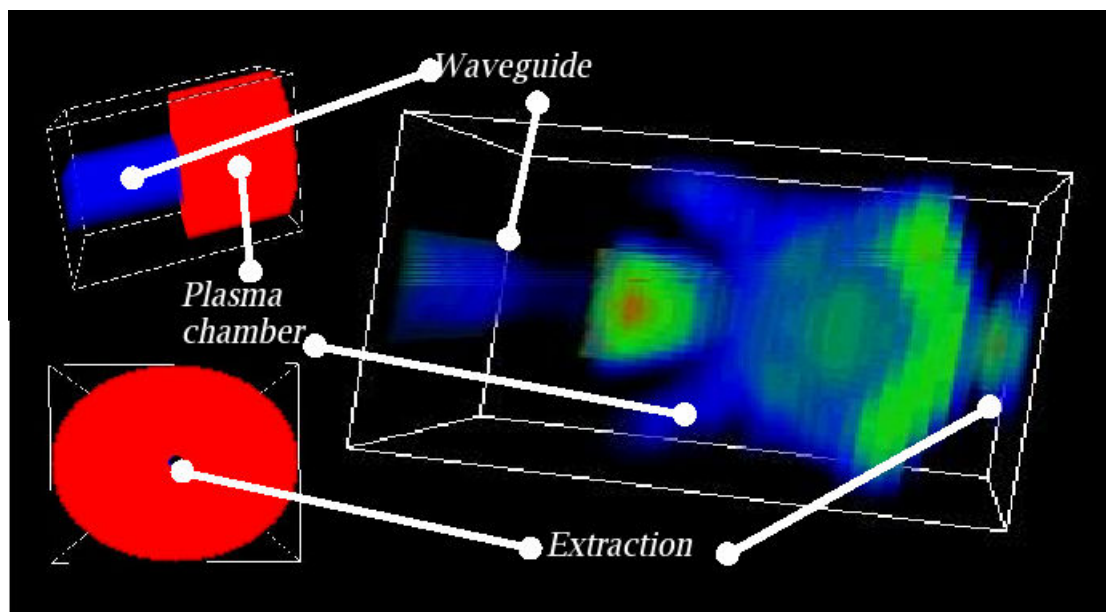


Figure JRA3.5.2: Snapshot of the output of the FDTD solver. Here, the amplitude of the vertical electrical component in the different domains (waveguide, plasma chamber and extraction hole).

#### *JRA3.5.2.2 Beam space charge neutralization study*

The work aims to provide to the linac designer estimates to calculate the rise time and the level of compensation in respect to his linac characteristics (front-end). For H<sup>-</sup> beams, the rise time and the neutralization level may be computed with simple formulae. The H<sup>+</sup> beam case is more difficult as the possibilities to loose the electrons and to keep a part of the ions are numerous (initial energy of e<sup>-</sup>, large mass for ions provided by the residual gas, heating of the e<sup>-</sup> by the beam). These few rules are valid in a simple thin drift. To take into coupling induced by electromagnetic elements and the pipe, PIC simulations is one studied solution. First experimental comparisons are encouraging but more data are needed to estimate the errors on the measurement (see figure below).

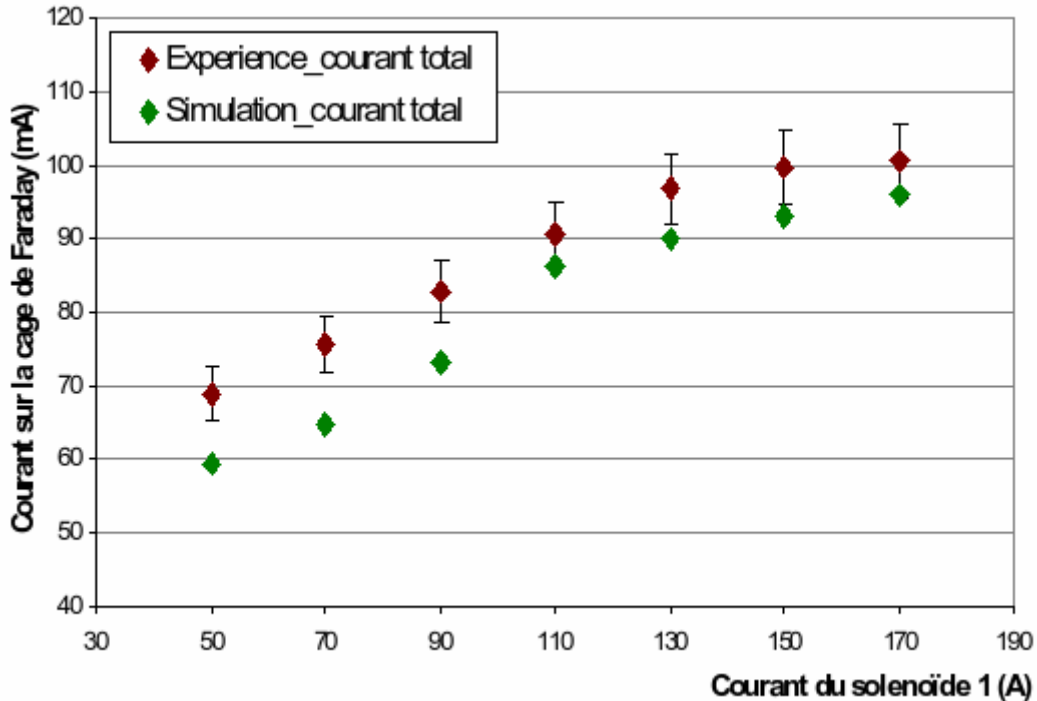


Figure JRA3.5.3: Comparison of simulated transmission and the measured one.

### JRA3.5.3 CERN Activities

#### JRA3.5.3.1 End-to-end simulations for LINAC4

End-to-end simulations for LINAC4 have resulted in an improved design with higher integrated gradient and little influence on beam dynamics. The simulations have shown that for 70 mA the chopper line is at the limit of its acceptance, which requires some modifications.

#### JRA3.5.3.2. Halo measurement device: design and construction

The halo monitor with high speed, large dynamic range, and large active area has been assembled and tested with UV light (see figure JRA3.5.4) which completes this task successfully. Considerations for tests with a proton beam are under way.

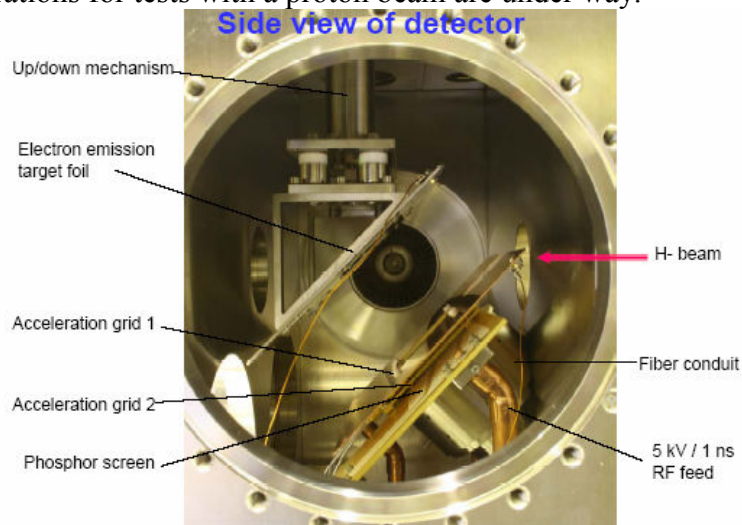


Figure JRA3.5.4: Inside view of the Halo measurement device.

### JRA3.5.4 FZJ Activities

### JRA3.5.4.1 Slot finger structure development

The structure has been developed for acceleration of high intensity beam in the range 2-3 up to 25-40 MeV. Electrodynamics studies and beam dynamics studies for zero current were carried out. Simulation with space charge has been started and is in progress.

### JRA3.5.4.2 Beam profile monitor

A non-interceptive device for profiles of very short and intense ion beam pulses based on luminescence of residual gas atoms has been tested in the beam line. Reduction of background and increase of sensitivity are next steps to be carried out

## JRA3.5.5 GSI Activities

### JRA3.5.5.1 Preparation of the Benchmarking Experiment in the UNILAC Alvarez DTL

Preparatory measurements using the complete diagnostics in the UNILAC Alvarez-DTL have been successful. The measurements have been carried out with the RF in different DTL tanks switched off in order to better localize the emittance growth. Comparison with simulations has confirmed the dominant vertical growth, with good quantitative agreement. Further preparations prior to the official experimental "Experimental study of high-intensity effects on beam quality in the DTL section of the UNILAC" to be carried out in 2006 are being made.

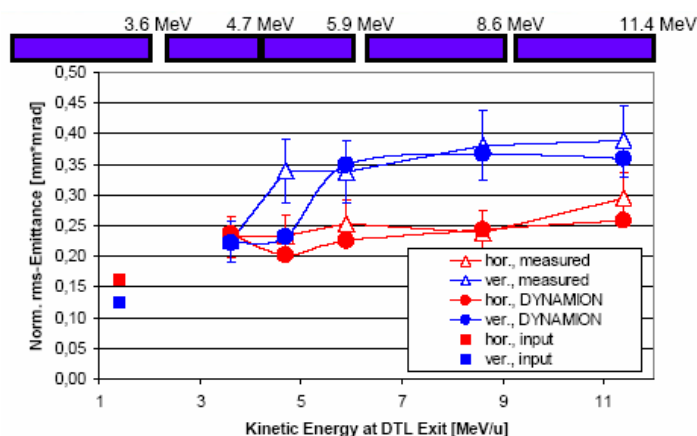


Figure JRA3.5.5: Measured and simulated emittances along the UNILAC linac.

### JRA3.5.5.2 Fluorescence Beam Profile Monitor

The device, using the method of fluorescence detection from the residual gas in the 400 nm wavelength range, has been successfully tested behind the last module of the UNILAC for both transverse planes. The data acquisition and presentation systems are practically ready for further tests and completing the unit.

## JRA3.5.6 IAP-FU Activities

### JRA3.5.6.1 LORASR code development:

A new LORASR PIC 3D FFT space charge routine was implemented. It provides the ability to perform simulations with up to 1 million macro-particles routinely, and within a reasonable computation time. The new LORASR space charge routine was successfully validated within the HIPPI Static Poisson Solver Comparison Program.-Within the framework of HIPPI code comparison, LORASR was included to the tracking calculations of the GSI UNILAC Alvarez section. Other LORASR code developments with HIPPI relevance, as the implementation of machine error settings were started

## JRA3.5.7 CNRS-LPSC Activities

### JRA3.5.7.1 Code parameter optimization:

For the LINAC 4 DTL complete error studies with random error sets including space charge have been carried out successfully using TRACEWIN. Little effect was found for the longitudinal errors. The overall quality degradation in the DTL was found acceptable.

### JRA3.5.8 Overall Progress of Work Package 5

The following table highlights the progress of work planned in the year 2005 for the work package WP5 by listing the lowest level subtasks of the HIPPI detailed implementation plan.

WP5	Title	Original begin date	Original end date	Estimated Status	Revised end date
5.1	<b>Code development</b>				
5.1.1	Preparation, Dev. of 3D space charge routines, Testing	Jan.2004	Jun. 2006	70 %	On time
5.1.2	LORASR development	Jan.2004	Dec. 2005	90 %	On time
5.1.3	Transport in 3D map implementation	Jan. 2004	Dec. 2005	90%	On time
5.1.4	Improvement, modeling high current	Jan. 2004	Jun. 2006	70%	On time
5.1.5	Codes preparation for 3 MeV test stand	Jan. 2004	Dec. 2006	60 %	On time
5.1.6	Codes preparation for SC linacs	Jan. 2004	Dec. 2006	60 %	On time
5.2	Experiment at UNILAC: preparation & simulations	Jan. 2004	Jun. 2006	40 %	On time
5.3	<b>Diagnostics and collimation</b>				
5.3.1	Profile measurement prototype design and construction (GSI)	Jul. 2004	Feb. 2005	100%	On time
5.3.2	Profile measurement testing (GSI)	Mar. 2005	Jun. 2006	60%	On time
5.3.3	Non-interceptive bunch measurement design (GSI)	Oct. 2004	Dec. 2006	40%	On time
5.3.4	Halo measurement device design & construction (CERN)	Jan. 2004	Jun. 2005	100 %	On time
5.3.5	Beam profile monitor design (FZJ)	Jan. 2005	Jun. 2007	50%	On time
5.3.6	Collimators design (CERN)	Jan. 2005	Dec. 2006		

**JRA3.6 Significant Achievements**

- The definition of an optimized beam dynamics and RF structure layout for a Drift Tube Linac tank from 3 to 10 MeV beam energy. This layout will be used for the construction of a high-power prototype.
- The successful cool-down and tests of superconducting spoke cavities at 700 MHz (FZJ) and 352 MHz (IPNO).

**JRA3.7 List of all milestones and deliverables (D) during the reporting period**

<b>WP2</b>	<b>Title</b>	<b>Due date</b>	<b>Status</b>	<b>Revised delivery date</b>
2.2.5	Test of CH model cavity: intermediate report	December 2005	On time	
2.2.8	Design report on beam dynamics in the CH-DTL	June 2005	Delayed	September 2005
2.4.1	Construction of CCDTL pre-prototype: intermediate report	June 2005	Delayed	December 2005
<b>WP3</b>	<b>Title</b>	<b>Due date</b>	<b>Status</b>	<b>Revised delivery date</b>
3.1.4	Cavity A tuner: intermediate report	December 2005	Delivered	
3.2.2	Report on evaluation of 760 MHz prototype	March 2005	Delivered	
3.2.3	Report on evaluation of 352 MHz 2gaps- proto	October 2005	Delivered	
3.2.6	Design report on 352 MHz 3-gaps resonator	May 2005	Results available	December 2005
3.3.1	Report on CH tuners	June 2005	Delayed	March 2006
<b>WP4</b>	<b>Title</b>	<b>Due date</b>	<b>Status</b>	<b>Revised delivery date</b>
4.1.1	Chopper A design report	June 2005	delayed	December 2005
4.1.2	Intermediate test report	March 2005	Waiting for task 4.1.5	March 2006
4.2.2	Dump design report	June 2005	pending	October 2005
4.3.1	Chopper B intermediate report	June 2005	Delivered	July2005

**JRA3.8 List of major meetings organized under HIPPI during the reporting period**

<b>Date</b>	<b>Title/subject</b>	<b>Location</b>	<b>Number of participants</b>	<b>Comments and Web site</b>
Jan. 27-28	IPHI-SPL collaboration meeting	CERN (CH)		<a href="https://edms.cern.ch/file/554659/1/Summary_6th_IPHI-CERN_Collaboration_meeting.pdf">https://edms.cern.ch/file/554659/1/Summary_6th_IPHI-CERN_Collaboration_meeting.pdf</a>
Jan28-Feb6	ISTC projects # 2888	CERN (CH)		<a href="https://edms.cern.ch/file/571711/1/Summary_of_CERN-ITEP_meeting_04.03.2005.doc">https://edms.cern.ch/file/571711/1/Summary_of_CERN-ITEP_meeting_04.03.2005.doc</a>
March 13-14	Workshop of HIPPI WP3	INFN-MI (Italy)		<a href="http://hippiwp3.in2p3.fr/Meeting%20INFN%20Milan%202005.htm">http://hippiwp3.in2p3.fr/Meeting%20INFN%20Milan%202005.htm</a>
April 13 -14	Workshop of HIPPI WP4	Abingdon (UK)		<a href="http://confest.isis.rl.ac.uk/Programme/wp4/">http://confest.isis.rl.ac.uk/Programme/wp4/</a>
April 14 - 15	Workshop of HIPPI WP5	Abingdon (UK)		<a href="http://confest.isis.rl.ac.uk/Programme/wp5/">http://confest.isis.rl.ac.uk/Programme/wp5/</a>
April 13 -14	ISTC project # 2875	Snezinsk (RU)		
April 18 -19	ISTC projects # 2888 and 2889	Sarov (RU)		
June 2 - 3	Workshop of HIPPI WP2	CERN (CH)		<a href="http://hippiwp2.in2p3.fr/Liste%20Meeting%20june%202005.htm">http://hippiwp2.in2p3.fr/Liste%20Meeting%20june%202005.htm</a>
August 17-19	ISTC projects # 2888 and 2889	CERN (CH)		
Sept. 28 – 30	HIPPI annual meeting	Abingdon (UK)	43	<a href="http://mgt-hippi.web.cern.ch/mgt-hippi/programme_HIPPI05.html">http://mgt-hippi.web.cern.ch/mgt-hippi/programme_HIPPI05.html</a>
October 10 - 13	ISTC project # 2875	CERN (CH)		
Nov. 17 - 18	IPHI-SPL collaboration meeting	Orsay (F)		<a href="https://edms.in2p3.fr/document/I-006838/2">https://edms.in2p3.fr/document/I-006838/2</a>
Nov. 23-25	CARE annual meeting	CERN (CH)		<a href="http://hep-lab.web.cern.ch/HEP-lab/CARE05/JRANA.htm">http://hep-lab.web.cern.ch/HEP-lab/CARE05/JRANA.htm</a>
Dec. 6 - 7	ISTC projects # 2888 and 2889	CERN (CH)		



#### 1.4.4 JRA4: Next European Dipole (NED)

The list of participants and of their implication in the NED Work Packages (C: Coordination, X: Participation) is given in the table bellow. The overall management is done by CEA and TEU.

Number	Participant	WP1 M&C	WP2 TSQP	WP3 CD	WP4 IDI	WG MDO <sup>a)</sup>	Person- months
1	CEA	C	X	X	X	X	27.1
10	INFN	X	C	X			16 (5)
	INFN-Ge	X		X			-
	INFN-Mi	X	C	X			16 (5)
11	TEU	X		X			8
15	WUT	X	X				23.4 (12)
16	CSIC	X				C	-
	CIEMAT	X				X	-
17	CERN	X		C		X	12
20	CCLRC	X	X		C	X	19.55
	CCLRC-RAL	X	X		C	X	19.55

a) The Working Group on Magnet Design and Optimisation (WGMDO) is an extension of scope with respect to CARE Annex 1.

#### JRA4.1 Work Package 1: Management and Communication (M&C)

##### 2004 Summary

The NED Steering Committee (SC) has met four times (8 January, 25 March, 8 July and 29 October), while the NED External Scientific Advisory Committee (ESAC) has met once (24 March) and has produced a report.

The NED work breakdown structure has been implemented by E. Deluncige (CERN) into the CERN Engineering Data and Management Service (EDMS) <https://edms.cern.ch> under CERN/AT Department/CARE. This service is used to release, circulate, track and store documents. Access is restricted to members of the NED collaboration (as identified in EDMS 547908).

A dedicated web page has been set up by A. den Ouden (TEU) <http://lt.tnw.utwente.nl/project.php?projectid=9>. The webpage is updated regularly with all information pertinent to the NED JRA and is accessible by the general public.

Detailed implementation plans of the three technical Work Packages (Thermal Studies and Quench Protection or TSQP, Conductor Development or CD, and Insulation Development and Implementation or IDI) have been established and launched and all collaborators have started their activities. In addition, the Activity scope has been extended, thanks to the setting up of a Working Group on Magnet Design and Optimization (WGMDO), supported by CCLRC and by additional resources from CEA, CERN and CIEMAT, a CARE Associated Laboratory who has decided to join the NED collaboration.

Three status reports have been produced

- 2<sup>nd</sup> quarter of 2004: EDMS 548027
- 3<sup>rd</sup> quarter of 2004: EDMS 548028
- Yearly report for 2004: EDMS 548030V4

## 2005 Summary

The NED Steering Committee (SC) has met four times: 20 January and 14 April at CERN, 7 July at WUT and 24 November at CERN.

A total of 5 papers (4 contributed and 1 invited) have been presented at international conferences pertinent to NED. Four of them will be published in peer-reviewed journals.

Three status reports have been produced

- 1<sup>st</sup> quarter of 2005: EDMS 588774V2
- 2<sup>nd</sup> quarter of 2005: EDMS 673326V2
- Yearly report for 2005: EDMS 689720

### JRA4.1.1 Overall Coordination

The NED JRA is coordinated by A. Devred (CEA&CERN), helped by A. den Ouden (TEU).

The following actions have been carried out and/or are foreseen

- 19–21 November 2003: participation of A. Devred (CEA&CERN) and A. den Ouden (TEU) to CARE Kick Off meeting at CERN
- 13 January 2004: visit of A. Devred (CEA&CERN) to INFN-Ge
- 16 January 2004: visit of P. Védérine (CEA) and A. Devred (CEA&CERN) to CIEMAT
- 27 January 2004: visit of A. Devred (CEA&CERN) to TEU
- 13 February 2004: A. Devred (CEA&CERN), P. Lebrun and L. Rossi (CERN) to INFN-Mi
- 23–24 February 2004: participation of A. Devred (CEA&CERN) to CARE Steering Committee and Dissemination Board meetings in Paris, France
- 19 March 2004: visit of F. Rondeaux and P. Védérine (CEA), A. Devred (CEA&CERN) to CCLRC
- 22–24 March 2004: participation to Workshop on Accelerator Magnets Superconductor (WAMS) organized within the framework of AMT Work Package of HHH Network Activity
- 13 April 2004: visit of A. Devred (CEA&CERN) and M. Pojer (CERN) to INFN-Ge
- 2–3 June 2004: visit of B. Baudouy and F. Michel (CEA), A. Devred (CEA&CERN), R. Van Weelden (CERN) to WUT
- 24–25 June 2004: participation of A. Devred (CEA&CERN) and A. den Ouden (TEU) to CARE Steering Committee and Dissemination Board meetings in Warsaw, Poland
- 24 August 2004: visit of M. Chorowski (WUT) to CEA/Saclay
- 2–5 November 2004: participation of A. Devred (CEA&CERN) to CARE general meeting at DESY
- 11–12 November 2004: participation of a number of NED collaborators to the HHH/AMT annual meeting at CERN.
- 3–4 March 2005: participation of a number of NED collaborators to the HHH meeting on Beam-Generated Heat Deposition and Quench Levels in LHC Magnets organised at CERN.
- 22–23 March 2005: participation of a number of NED collaborators to the HHH/AMT meeting on Insulation & Impregnation Technique organised at CERN
- 5–6 September 2005: participation of A. Devred (CEA&CERN) to CARE Steering Committee and Dissemination Board meetings in Paris
- 22–25 November 2005: participation of a number of NED collaborators to CARE general meeting at CERN

- 23 November 2005: participation of a number of NED collaborators to the HHH/AMT annual meeting at CERN
- 24 November 2005: participation of A. Devred to CARE Governing Board and Dissemination meetings at CERN

## JRA4.1.2 Meetings

### JRA4.1.2.1 Steering Committee Meetings

The oversight of the NED JRA is ensured by a Steering Committee (SC) made up of

- E. Baynham (CCLRC)
- A. Devred (CEA&CERN), Chairman
- D. Leroy (CERN)
- J.M. Rifflet (CEA)
- G. Volpini (INFN-Mi)
- A. den Ouden (TEU), Secretary

SC meetings are held every three months. Available copies of the presentations and minutes of the meetings have been loaded into EDMS and are posted on the NED website.

The following actions have been carried out and/or are foreseen

- 8 January 2004: meeting at CERN  
participants: E. Baynham (CCLRC), A. Devred (CEA&CERN), D. Leroy, L. Oberli and O. Vincent-Viry (CERN), P. Fabbriatore (INFN-Ge), G. Volpini (INFN-Mi), A. den Ouden (TEU)  
special guests: L. Rossi (CERN), H. ten Kate (CERN&TEU)  
agenda+talks: EDMS 548032; also available on NED website
- 25 March 2004: meeting at CERN  
participants: B. Baudouy and J.M. Rifflet (CEA), A. Devred (CEA&CERN), D. Leroy and R. van Weldeeren (CERN), F. Toral (CIEMAT), G. Volpini (INFN-Mi), E. Baynham and S. Canfer (CCLRC), A. den Ouden (TEU)  
special guests: A. Yamamoto (KEK), S. Gourlay (LBNL)  
agenda+talks: EDMS 548033; also available on NED website
- 8 July 2004: meeting at CERN  
participants: E. Baynham and S. Canfer (CCLRC), A. Devred (CEA&CERN), F. Rondeaux and P. Védrine (CEA), T. Boutboul, D. Leroy, L. Oberli, V. Previtali, O. Vincent-Viry, R. van Weldeeren (CERN), P. Fabbriatore and S. Farinon (INFN-Ge), M. Sorbi (INFN-Mi), A. den Ouden (TEU)  
special guests: –  
agenda+talks: EDMS 548034; also available on NED website
- 29 October 2004: meeting at CEA/Saclay  
participants: S. Canfer (CCLRC), A. Devred (CEA&CERN), H. Felice, L. Quettier, J.M. Rifflet, F. Rondeaux, P. Védrine (CEA), T. Boutboul, D. Leroy, L. Oberli, V. Previtali, R. van Weldeeren (CERN), M. Greco (INFN-Ge), D. Pedrini, M. Sorbi, G. Volpini (INFN-Mi), A. den Ouden (TEU), M. Chorowski, J. Polinski (WUT)  
special guests: R. Aleksan (CPPM), P. Debu, M. Durante (CEA), B. Adamowicz (Kryosystem)  
agenda+talks: 548035; also available on NED website
- 20 January 2005: meeting at CERN  
participants: S. Canfer, E. Baynham (CCLRC), A. Devred (CEA&CERN), F. Michel, J.M. Rifflet (CEA), T. Boutboul, P. Fessia, D. Leroy, L. Oberli, D. Richter, W. Scandale, C. Scheuerlein, N. Schweg, S. Sgobba (CERN),

P. Fabbriatore, S. Farinon, M. Greco (INFN-Ge), F. Broggi, V. Granata, M. Sorbi, G. Volpini (INFN-Mi), A. den Ouden (TEU)  
agenda+talks: 548036; also available on NED website

- 14 April 2005: meeting at CERN  
participants: S. Canfer, E. Baynham (CCLRC), A. Devred (CEA&CERN), T. Boutboul, L. Oberli, C. Scheuerlein, R. Schmidt, S Sgobba, R. Van Weldeeren (CERN), F. Toral (CIEMAT), S. Farinon, M. Greco (INFN-Ge), V. Granata, M. Sorbi, G. Volpini (INFN-Mi), A. den Ouden (TEU), S. Petrowicz, M. Chorowski (WUT)  
agenda+talks: 575731
- 7 July 2005: meeting at WUT  
participants: S. Canfer (CCLRC), A. Devred (CEA&CERN), F. Michel, J.M. Rifflet (CEA), T. Boutboul, D. Leroy, L. Oberli, S Sgobba, R. Van Weldeeren (CERN), M. Greco (INFN-Ge), M. Sorbi, G. Volpini (INFN-Mi), A. den Ouden (TEU), S. Petrowicz, M. Chorowski (WUT)  
agenda+talks: 604114
- 24 November 2005: meeting at CERN  
participants: E. Baynham, S. Canfer, G. Ellwood (CCLRC), A. Devred (CEA&CERN), B. Baudouy, P. Védrine (CEA), T. Boutboul, A. Desirelli, P. Fessia, D. Leroy, L. Oberli, M. Pojer, F. Regis, D. Richter, V. Previtali, C. Scheuerlein, S Sgobba, R. Van Weldeeren (CERN), M. Greco, P. Fabbriatore, S. Farinon (INFN-Ge), F. Broggi, M. Sorbi, G. Volpini (INFN-Mi), A. den Ouden (TEU), M. Chorowski (WUT)  
agenda+talks: 680728  
⇒ next meeting: 23 February 2006 at CERN

#### **JRA4.1.2 External Scientific Advisory Committee Meetings**

##### JRA4.1.4 Overall Progress of the Activity

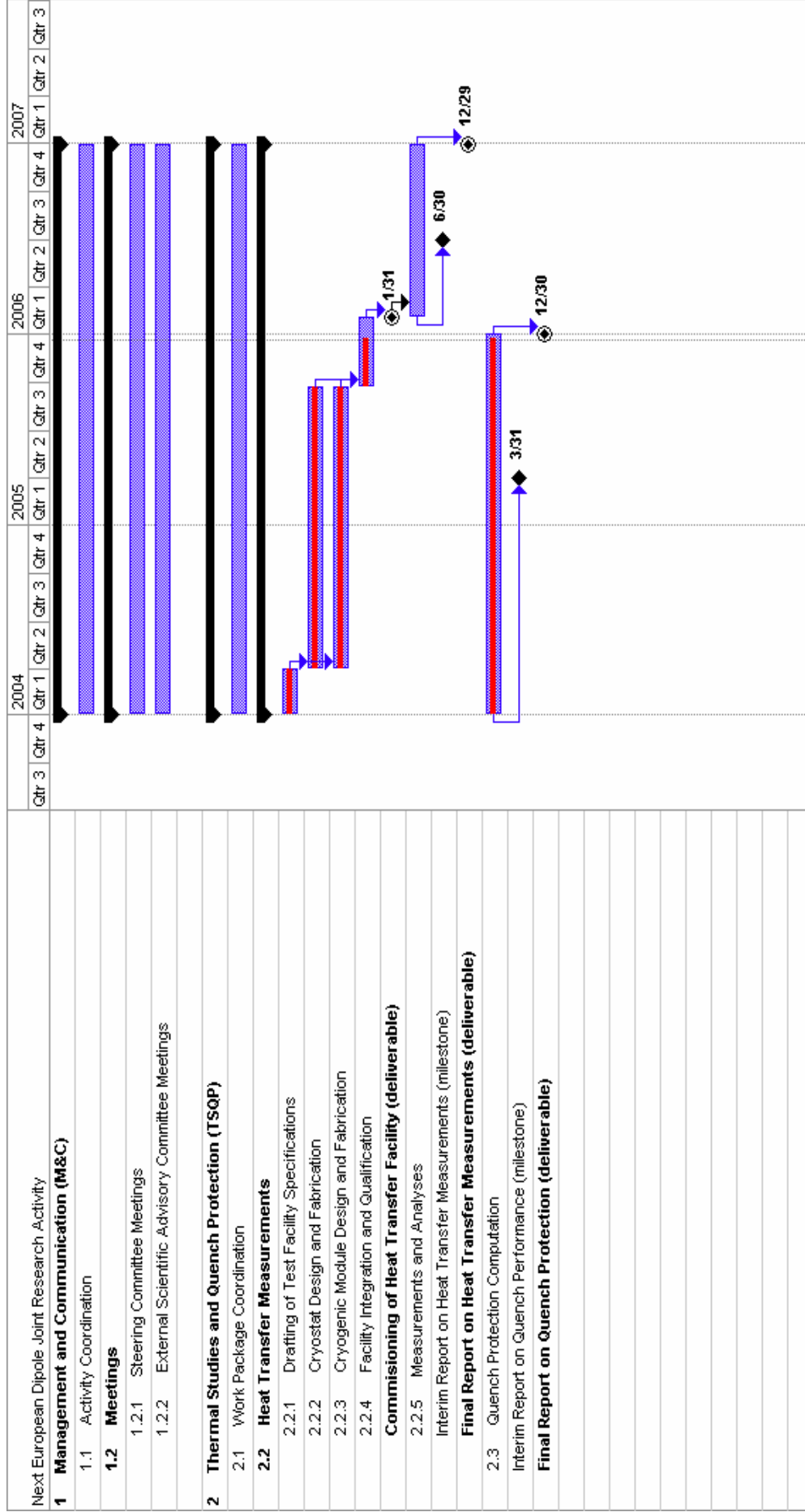
The NED JRA Coordinator is assisted by an External Scientific Advisory Committee (ESAC). The charges and composition of the committee are defined in EDMS 548039. The committee is made up of

- J.L. Duchateau (CEA)
- P. Lebrun (CERN)
- L. Rossi (CERN)
- R.M. Scanlan (formerly LBNL, retired)
- J.B. Strait (FNAL), Chairman
- H.H.J. ten Kate (CERN&TEU)

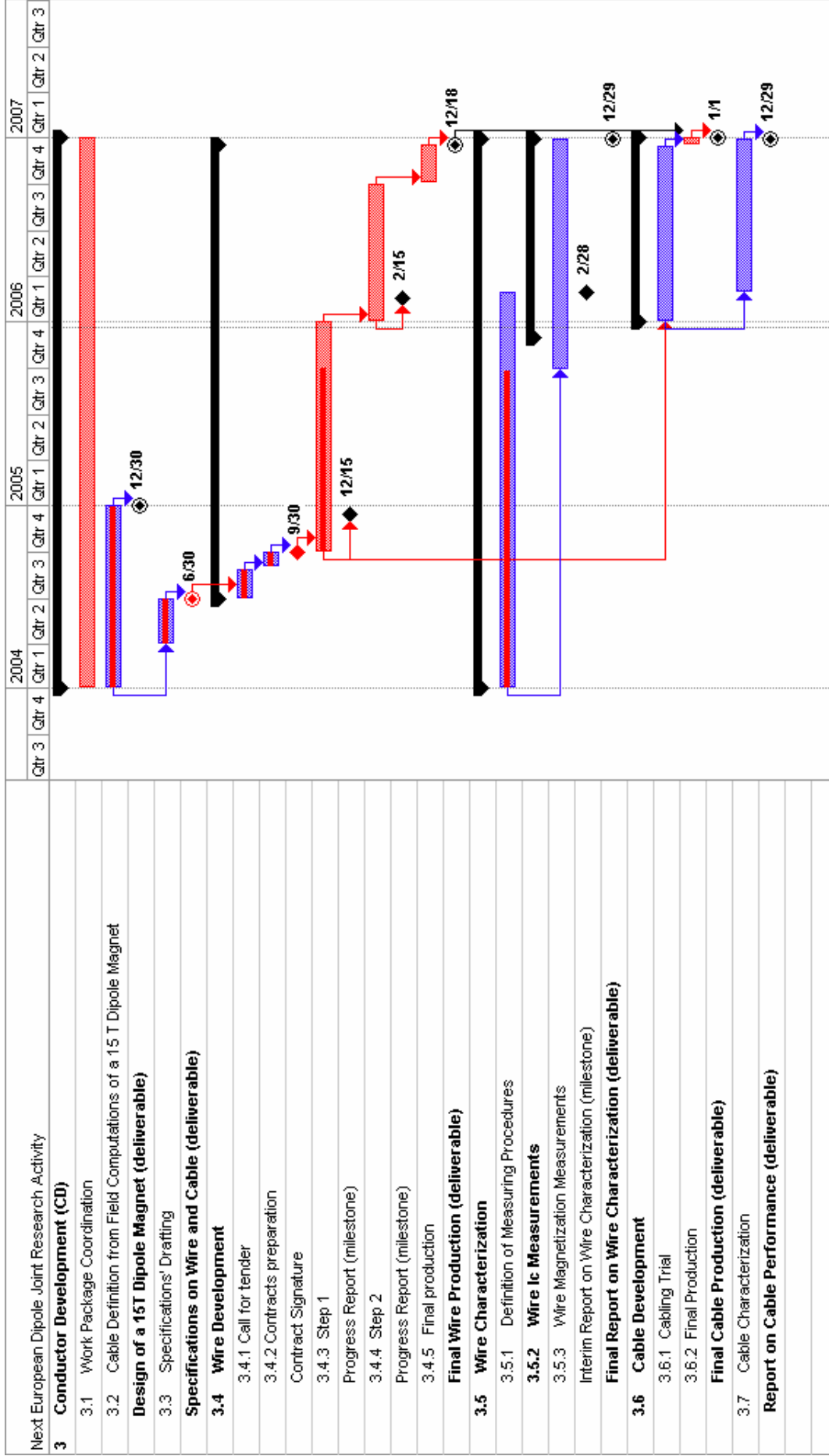
The following actions have been carried out and/or are foreseen

- 24 March 2004: first meeting at CERN  
agenda: EDMS 548039; presentations available on NED website
- 29 March 2004: first ESAC report (EDMS 548041)  
agenda+talks: 548035; also available on NED website  
⇒ next meeting: Spring of 2006

**Updated implementation plan (Gantt chart) for the NED/JRA as described in the Technical Annex of CARE Contract**



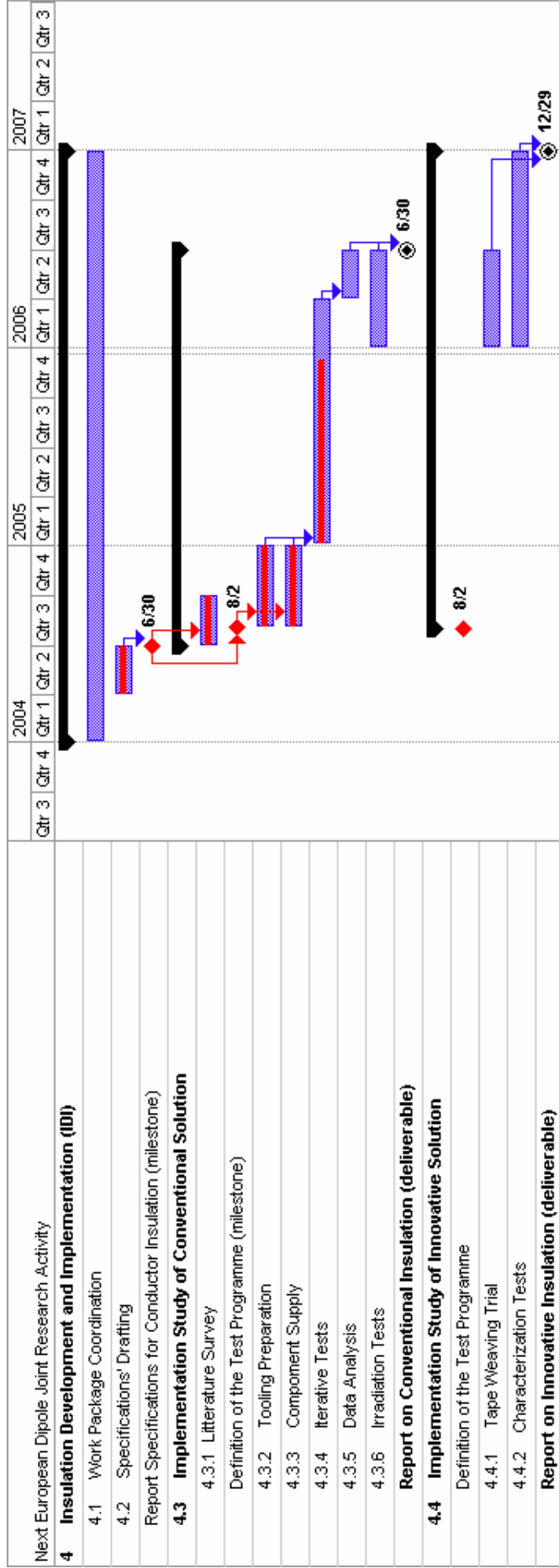
A. ACTIVITY REPORT



NB: the CARE Annex I milestone entitled "First Results on Wire Development" that was due on 30 June 2005 has been split into two "Status Reports" due on 15 December 2004 and 15 December 2005.



A. ACTIVITY REPORT



NB:

- Task 4.3.6 is an extension of scope with respect to CARE Annex I,
- The scope of Task 4.4.2 has been modified with respect to CARE Annex I.

## JRA4.2 Work Package 2: Thermal Studies and Quench Protection (TSQP)

Work Package 2 includes two main Tasks:

- development and operation of a test facility to study and characterize heat transfer to helium through Nb<sub>3</sub>Sn conductor insulation (involving CEA and WUT, under the supervision of B. Baudouy, CEA)
- quench protection computation (carried out by INFN-Mi, Task Leader: G. Volpini)

### 2004 Summary

The first part of the Task on heat transfer measurements was to design and build a new He-II, double-bath cryostat. CEA wrote detailed specifications that were handed out to WUT in June 2004. WUT performed a call for tender in the Summer of 2004 and selected Kryosystem in Poland to manufacture the cryostat. Work was started in the Fall of 2005 and a Production Readiness Review was held at Saclay on 29 October 2004.

After completing a literature survey of relevant material properties (EDMS 555753), INFN-Mi has carried out detailed quench computations based on the 88-mm-aperture,  $\cos\theta$ -layer design chosen as Reference Design V1 for NED in conclusion of Task 3.2. The computations study the influence of various parameters such as: magnet length (1, 5 and 10 m), operating current (15, 22 and 29 kA), value of external dump resistor (15, 25, 35 and 45 m $\Omega$ ), quench detection delay (30, 40 and 50 ms) and quench protection heater length. They are carried out using two independent codes: QLASA, originally developed at INFN-Mi for solenoids and subsequently adapted to accelerator magnet coil configuration by means of suitable geometric approximations, and QUABER, a collection of scripts written in MAST and run with the commercial interface SABER that was developed at CERN to study LHC magnet protection. An interim report (EDMS 555756) summarizes the results obtained for a 1-m-long and a 5-m-long magnet.

### 2005 Summary

Some delays have been encountered in the manufacturing of the cryostat and of the enclosed heat exchanger. Preliminary reception tests were held at WUT during the 3<sup>rd</sup> week of April, which revealed some problems. The problems were fixed in May-June 2005 and another round of tests was carried out at WUT on 6-8 July 2005. These tests included thermal and leak tests in liquid helium environment at 4.2 K and were deemed successful. The cryostat was then transported by road to CEA/Saclay, where it arrived on 20 September 2005. It is now being prepared for tests in He II and commissioning. The first measurements are expected to take place in early 2006.

In parallel, CERN is carrying out a detailed analysis of existing cold test data from LHC magnet models and prototypes so as to verify whether or not the high heat-transfer coefficients measured at CEA on coil mock-ups are also observed in actual magnets. The analysis is based on a review of quench data and of AC-loss measurement as a function of ramp rate and will be compared to similar work carried out at FNAL on LHC Insertion Region quadrupole magnet model. It is expected to be completed by December 2005.

CERN has also undertaken a review of cooling modes and has come to the preliminary conclusion that the most efficient one remains pressurized superfluid helium as chosen for the LHC. The heat removal capabilities of pressurized superfluid helium are very well suited to the magnet designs under consideration. The benefit from enhanced Nb<sub>3</sub>Sn critical current is as well an argument. As a result, it is likely that NED-like magnets will have to be operated at 1.9 K. The effort on magnet cooling optimization will be pursued within the framework of an existing collaboration between CERN and Wroclaw University of Technology.

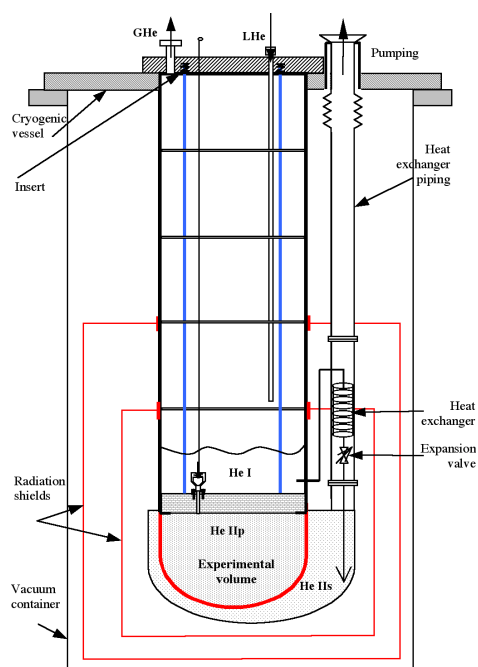


Figure JRA4.2.1. Conceptual design of double-bath cryostat for heat-transfer measurements developed by CEA/Saclay

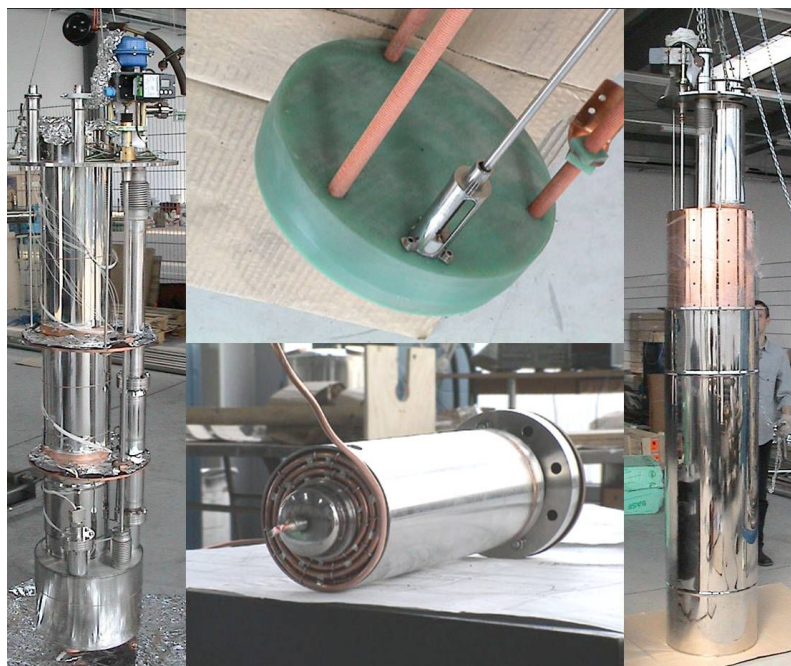


Figure JRA4.2.2. Various pictures of NED cryostat and of its critical components manufactured by Kryosystem in Poland, under the supervision of Wroclaw University of Technology: (a) inner assembly with instrumentation (left), (b) lambda plate (middle top), (c) heat exchanger (middle bottom) and (d) final assembly with thermal shields (right).

Quench computations have been carried out for a 10-m-long magnet relying on the reference 88-mm-aperture,  $\cos\theta$ , layer design. They confirm the results already obtained for smaller lengths: the hot spot temperature always remains below 300 K and the maximum voltage can be limited to 800 V by an adequate choice of dump resistor. This implies that that such type of magnet is safe to operate, thanks mainly to the choice of strand and cable parameters made early on. In addition, the two softwares that have been used (QLASA and QUABER) appear to yield similar results. To wrap up this Task, computations have been run on a more challenging 160-mm-aperture,  $\cos\theta$  slot design for a length of 5 m. The magnet protection, albeit feasible, appears more difficult than for the conventional  $\cos\theta$  layer design and requires efficient quench protection heaters in every slot. The final report on the protection of the  $\cos\theta$  layer designs was completed on 8 November 2005 (EDMS 683013) and is presently under peer review. The additional work on the  $\cos\theta$  slot design will be written as an Appendix. A summary paper on this Task was presented at the Magnet Technology Conference (MT'19) in Genova.

#### JRA4.2.1 TSQP Work Package coordination

As already mentioned, the TSQP Work Package is articulated around two main tasks: Heat Transfer Measurements (2.2) and Quench Computation (2.3). Task 2.2 is coordinated by B. Baudouy (CEA), while Taks 2.3 is coordinated by G. Volpini (INFN-Mi). Task Leaders report to the NED Steering Committee and, ultimately, to the NED/JRA Coordinator.

#### JRA4.2.2 Heat Transfer Measurements

The following actions have been carried out and/or are foreseen

##### JRA4.2.2.1 Drafting of Test Facility Specifications

- 28 January 2004: preparatory meeting at CEA/Saclay

participants: B. Baudouy, P. Chesny, B. Hervieu, F. Michel and J.M. Rifflet (CEA), A. Devred (CEA&CERN)

- 27 February 2004: programme proposal issued by B. Baudouy (CEA; EDMS 548123)
- March 2004: review of programme proposal by P. Lebrun and D. Leroy (CERN) and approbation by SC meeting
- 4 May 2004: cryostat specification issued by B. Baudouy, B. Hervieu and F. Michel (CEA; EDMS 548129V1)
- May 2004: specification submitted for review to P. Lebrun and R. Van Weelden (CERN) and M. Chorowski (WUT)
- 8 June 2004: final cryostat specification issued by B. Baudouy, B. Hervieu and F. Michel (CEA; EDMS 548129V2)

#### *JRA4.2.2.2 Cryostat Design and Fabrication*

- 3 June 2004: preparatory visit to Kryosystem (Poland)  
participants: B. Baudouy, F. Michel (CEA), A. Devred (CEA&CERN) R. van Weelden (CERN), M. Chorowski, J. Fydrych and J. Polinski (WUT), B. Adamowicz, G. Michalski and G. Strychalski (Kryosystem)
- July 2004: start of technical design at WUT
- July 2004: start of tendering procedure
- 10 August 2004: redefinition of WUT budget allocation
- August 2004: contract attribution to Kryosystem
- 29 October 2004: Production Readiness Review at CEA Saclay  
participants: B. Baudouy, F. Michel (CEA), R. van Weelden (CERN), M. Chorowski, J. Polinski (WUT), B. Adamowicz (Kryosystem)  
report: EDMS 548154)
- 17 November 2004: hiring of Grzegorz Michalski and Maciej Matkowski at WUT (additional staff; till 30 June 2005)
- Early April 2005: completion of manufacturing
- 20-22 April 2005: preliminary reception tests at WUT, in  
participants: B. Baudouy and F. Michel (CEA) and of M. Chorowski and J. Polinski (WUT)  
Test report: EDMS 587176
- 2 May 2005: set of recommendations issued by B. Baudouy, F. Michel (CEA) and A. Devred (CEA&CERN) – EDMS 587176
- 6 May 2005: report on mechanical design study issued by M. Chorowski and J. Polinski (WUT) – EDMS 592247
- 12 May 2005: first status report on repairs issued by M. Chorowski and J. Polinski (WUT) – EDMS 592246
- 19 May 2005: Comments on status report issued by B. Baudouy and F. Michel (CEA) – EDMS 593633
- 3 June 2005: second status report on repairs issued by M. Chorowski and J. Polinski (WUT) – EDMS 598854
- 3 June 2005: second version of report on mechanical design study issued by M. Chorowski and J. Polinski (WUT) – EDMS 592247V2
- 6-8 July 2005: second round of reception tests at WUT  
participants: B. Baudouy and F. Michel (CEA) and of M. Chorowski and J. Polinski (WUT)  
Test report: EDMS 609237

- 20 September 2005: reception of cryostat at CEA

#### *JRA4.2.2.3 Cryogenic Module Design and Fabrication*

- 22 June 2004: design specifications issued by B. Baudouy and F. Michel (CEA; EDMS 548139, based on design study reviewed in EDMS 548137)
- 1<sup>st</sup> July 2004: call for tender issued by F. Michel (CEA)
- 15 July 2004: reception of answers to call for tender
- 17 September 2004: purchase requisition to be issued by F. Michel (CEA)
- 10 October 2004: contract awarded to Kryosystem.
- Early April 2005: completion of manufacturing

#### *JRA4.2.2.4 Facility Integration and Qualification*

- September 2005 vacuum and pressure test
- September 2005: leak test
- October-November 2005: instrumentation, wiring and insulation
- December 2005: external cabling
- January 2006: He II commissioning.

#### *JRA4.2.2.5 Measurements and Analyses*

*Not started*

### **JRA4.2.3 Quench Protection Computation**

The following actions have been carried out and/or are foreseen

- 5 March 2004: draft computation programme issued by M. Sorbi and G. Volpini (INFN-Mi; EDMS 555747)
- March 2004 SC meeting: discussion of computation programme
- April–June 2004: compilation of material properties (EDMS 555753)
- June–October 2004: first computations on Reference Design V1 (88-mm-aperture,  $\cos\theta$ , layer design)
- November–December 2004: extended computations on Reference Design V1
- 25 November 2004: hiring of Valeria Granata by INFN-Mi (additional staff for 6 months)
- 3 February 2005: first version of interim report (EDMS 555756; EU milestone)  
authors: V. Granata, M. Sorbi, G. Volpini, D. Zamborlin (INFN-Mi)
- 13 April 2005: second version of interim report (EDMS 555756V2)  
authors: V. Granata, M. Sorbi, G. Volpini, D. Zamborlin (INFN-Mi)
- 24 May 2005: termination of Valeria Granata
- 29 September 2005: first version of MT19 paper
- 8 November 2005: first version of final report (INFN-Mi); EDMS 683013, EU deliverable
- 6 December 2005: final version of MT19 paper issued by M. Sorbi (EDMS 688572)

### JRA4.2.4 Overall Progress of Work Package 2

The following table highlights the progress of work planned in the year 2005 for the work package WP2 by listing the lowest level subtasks of the NED detailed implementation plan.

WP2	Title	Original begin date	Original end date	Estimated Status	Revised end date
2.1	TSQP WP Coordination				
2.2	Heat Transfer Measurements				
2.2.1	Drafting of Test Facility Specifications	1 Jan. 2004	31 Mar. 2004	Completed	8 Jun. 2004
2.2.2	Cryostat Design and Fabrication	1 Apr. 2004	31 Dec. 2004	Completed	8 Jul. 2005
2.2.3	Cryogenic Module Design and Fabrication	1 Apr. 2004	31 Dec. 2004	Completed	8 Jul. 2005
2.2.4	Facility Integration and Qualification	1 Jan. 2005	31 Mar. 2005	70 %	31 Jan. 2006
2.2.5	Measurements and Analyses	1 Apr. 2005	31 Dec. 2006	Not started	-
2.3	Quench Protection Computation	1 Apr. 2004	30 Jun. 2005	99 %	31 Dec. 2005

### JRA4.3 Work Package 3: Conductor Development (CD)

Work Package 3 includes three main Tasks:

- conductor development  
(under CERN supervision, Task Leader: L. Oberli)
  - conductor characterization  
(involving CEA, CERN, INFN-Mi, INFN-Ge and TEU, under the supervision of A. den Ouden, TEU)
  - FE wire model to simulate cabling effects  
(involving CERN and INFN-Ge and TEU, under the supervision of S. Farinon, INFN-Ge)
- The CD Work Package is the core of the program and will absorb about 70% of the EU funding.

### 2004 Summary

CERN has investigated two different magnetic designs, referred to as  $\cos\theta$  layer design and  $\cos\theta$  block design and has considered 3 apertures: 88 mm, 130 mm and 160 mm. These investigations, described in a report (EDMS 555826), led to the definition of wire and cable parameters used as a basis for conductor specifications. The 88-mm-aperture,  $\cos\theta$  layer design has been chosen as a baseline for NED (Reference Design V1 as defined in EDMS 555825). One particularity of this design is that it calls for a wide cable (26 mm) made up of 40 stands of large diameter (1.25 mm) and high critical currents ( $\geq 1636$  A at 4.2 K and 818 A at 15 T and 4.2 K). This reliance on a large conductor and a large transport current is a deliberate choice that differentiates the NED program from what is done in the USA where the emphasis is put on achieving the highest possible critical current density and on adapting conductor and magnet design so as to optimize performances with respect to this parameter.

After writing comprehensive wire and cable specifications and a detailed technical questionnaire (EDMS 475443), CERN has issued a call for tender in June 2004 and has selected in November 2004 Alstom/MSA, in France, and ShapeMetal Innovation (SMI), in the Netherlands, to be the main wire and cable contractors. After discussion with CERN, the two companies have established development plans made up of two R&D steps (referred to as STEP1 and STEP2) followed by final production. For Alstom/MSA, which promotes the “Enhanced Internal Tin” process, STEP1 is devoted to a Taguchi-type plan to study the



influence of salient parameters on workability and performances, while STEP2 will be devoted to a tuning of critical current density. For SMI, which promotes the "Powder In Tube" process, STEP1 is devoted to iterations on an existing, 1-mm-diameter, wire design, which has reached a non-copper critical current density of 2500 A/mm<sup>2</sup> at 4.2 K and 12 T, while STEP2 will be devoted to a scale-up to larger-size billets. The results of STEP1 are expected in the Fall of 2005, while those of STEP2 are expected in the Summer of 2006. Both companies have started the procurements of raw materials.

A Working Group on Conductor Characterization (WGCC) made up of representatives from CEA, CERN, INFN-Mi, INFN-Ge and chaired by A. den Ouden (TEU) has been set up in the Spring of 2004 to oversee wire  $I_C$  and magnetization measurements. The Working Group has initiated a cross-calibration of the various test facilities available to perform these measurements. In parallel, INFN-Ge has undertaken a series of magnetization measurements with different types of apparatus to evaluate their respective pertinence, including a SQUID magnetometer at INFN, Genova, a Vibrating Sample Magnetometer (VSM) at LNF and an AC-susceptibility magnetometer available in house. These measurements were carried out either as a function of field, to assess effective filament diameter and the amplitude of flux jumps, or as a function of temperature, to study the nature and size of the various superconducting phases.

An effort has been launched by INFN-Ge to develop a FE mechanical model of un-reacted wires so as to simulate the effects of cabling and derive optimum billet layout. This model was first applied to an old, ITER-type, internal-tin wire design produced by Alstom/MSA (EDMS 548087). However, to be accurate, it requires a detailed knowledge of the properties of the materials that make up the wire in their cold work state at the end of drawing. CERN has undertaken a literature survey of these properties and has launched a series of nano-hardness and micro-hardness measurements on cross-cuts of the Alstom/MSA ITER-type wire to check and complement these data. The nano-hardness measurements are sub-contracted to a laboratory of Ecole d'Ingénieurs de l'Arc Jurassien (EIAJ, located in Le Locle, Switzerland) while the micro-hardness measurements are performed in house. Two reports (EDMS 548100 for EIAJ and EDMS 548116 for CERN) summarize these measurements.

### 2005 Summary

Both industrial sub-contractors have received their raw materials and have started assembling and transforming STEP1 billets.

During STEP1, SMI has tried to increase the non-copper critical current density of the 192 filament Powder In Tube strand to a value above 2500 A/mm<sup>2</sup> at 12 T. SMI has produced 2 billets using a tantalum barrier around the niobium tube of each filament and 2 billets (called B201 and B205) with a modified powder composition without using a tantalum barrier. The drawing to a diameter of 1 mm of the 2 billets using a Ta barrier was not successful due to a large number of breakages attributed to a poor quality of the Ta barrier. The 2 other billets B201 and B205 were drawn without breakage to a diameter of 1 mm and two unit lengths of 327 m and 320 m were delivered to CERN. A critical current density around 2350 A/mm<sup>2</sup> at 12 T was measured on the billet B201, much lower than expected due to Sn leakage occurring at the melting point of Sn. A piece length of 20 m of another billet called B179 was delivered to CERN. On a sample of the billet B179, a critical current density of 2584 A/mm<sup>2</sup> at 12 T was obtained by SMI.

CERN has carried out an extensive program to characterize the strands. A RRR value of 220 was measured on a sample of the billet B179 above the specified NED value. RRR measurements performed on samples of the billet B201 have confirmed the Sn leakage in the copper matrix. The Sn leakage is a consequence of the rupture of the Nb tube. Metallographic

strand cross-sections of the reacted strand have permitted to observe a burst Nb tube by optical microscopy, which explains the low critical current density. Same test will be performed on the billet B205 as Sn leakage was also reported by SMI, even if the free Sn content in the powder was decreased compared to the Sn content used in the powder of the billet B201. CERN has also investigated the strand behaviour under heavy deformation to evaluate if the strands are indeed capable to sustain the cabling. Samples of the 2 billets B179 and B201 were rolled down at CERN to flatten the strand from 1 mm to 0.85, 0.75 and 0.65 mm. The filament layout was observed by optical metallography of the cross-section of the samples. Whereas the filament layout of the billet B179 rolled to 0.75 mm was severely deformed showing shear fracture planes crossing the filaments, the filament layout of the billet B201 was able to sustain the high unidirectional deformation. More extensive investigations will be launched on samples from billets B179 and B205 to understand how the internal filament layout sustains the deformation by rolling. For the next period, the effort will be focused on the qualification of the final design by using filaments identical to the billet B179 with equal powder composition and with more copper around the filaments as for the billet B201.

For STEP1, Alstom/MSA has launched 5 types of strand in fabrication following an internal tin process. The different layouts were discussed with CERN with the aim to determine the optimum design to get a good workability and a high critical current. Alstom/MSA has encountered few problems in the preparation of the Sn rods used in billet assembly and in the extrusion of the monofilament billets. Solutions have been found and CERN has contributed by performing quality assurance tests on the Sn rods to verify the suitability of the process and acid cleaning of the Nb bars. All intermediate billets have been assembled and drawn. Only one type of intermediate billets with a central Sn core was successfully drawn without breakages to restacked dimension. Alstom/MSA has investigated the possible reasons and has decided in agreement with CERN to produce two additional intermediate billets with a modified process. A revised plan for STEP2 is in discussion with CERN to improve the manufacturing process followed for STEP1 and to develop alternative manufacturing process for intermediate billets. The first results of STEP1 are expected in January 2006, while those of STEP2 are expected in the Summer of 2006.

The cross-calibration program launched by the Working Group on Conductor Characterization has proven more difficult than anticipated. Three rounds of “virgin” test wires have been circulated among the various laboratories and have pointed out a number of problems and discrepancies in sample preparation and instrumentation as well as in measurement procedures. The first round included a reference, LHC-type, NbTi wire, and two Nb<sub>3</sub>Sn wires: one 1.26-mm-diameter ECN PIT wire provided by TEU and one 0.83-mm-diameter EM Internal Tin wire provided by INFN-Mi (the EM wire samples were either “virgin” or extracted from a Rutherford-type cable). The second round relied again the 1.26-mm-diameter ECN PIT wire, while the third round included a 1-mm-diameter, SMI, ternary Nb(Ta)<sub>3</sub>Sn, PIT wire, also provided by TEU. INFN-Mi and TEU have now achieved a good convergence on  $I_C$  measurements (results for the SMIT PIT wire samples agree within 2%) while CEA is still in the process of upgrading its test facility. The third round also included “virgin” and “deformed” samples of the 1.26-mm-diameter ECN PIT wire to evaluate cabling degradation (the wire was rolled down at CERN with diameter reductions of 0.30, 0.35, 0.40 and 0.45 mm, but only the samples with a 0.35-mm diameter reduction were tested). The INFN-Mi and TEU measurements of these samples show a larger dispersion (5 to 7%) than for the SMI PIT wire measurements (which may be due to heterogeneity in the wire itself); the  $I_C$  degradation between deformed and virgin samples is estimated around 40%. A status

report on the cross-calibration program was presented at the Magnet Technology Conference (MT'19) in Genova (EDMS 690009).

INFN-Ge has carried out detailed investigations of the 1.26-mm-diameter ECN PIT wire mentioned above to develop his characterization techniques. Magnetization measurements performed as a function of temperature (in a 10-mT parallel field) with a SQUID magnetometer clearly show two transitions: one for a temperature of  $\sim 17.4$  K, corresponding to  $\text{Nb}_3\text{Sn}$ , and one around 9.2 K, corresponding to pure Nb. The origin of these two transitions can be readily understood when considering the wire structure: it is drawn down from a billet made up from thick-walled niobium tubes, arranged in a pure copper matrix and stuffed with a mixture of  $\text{NbSn}_2$ , Cu and Sn powders. During heat treatment, the powder mixture reacts with the Nb tubes and precipitate  $\text{Nb}_3\text{Sn}$  layers, which grow from the inner to the outer radii of the tubes. The heat treatment is usually optimized so as to react about  $2/3^{\text{rd}}$  of the tube walls, thereby leaving a sheath of un-reacted niobium at the tube periphery. As a result, when cooling down the ECN PIT wire to cryogenic temperatures in a small background magnetic field, a first transition occurs when the  $\text{Nb}_3\text{Sn}$  layers on the inner part of the tubes become superconducting, and a second transition follows when the un-reacted Nb sheaths on the outer part of the tubes, in turn, become superconducting. Furthermore, the amplitudes of the magnetizations measured in these two stages enable one to determine the magnetically-shielded volumes which are associated and, thereby, the outer diameters of the reacted  $\text{Nb}_3\text{Sn}$  layers and of the un-reacted Nb tubes. In our example, we get: 44  $\mu\text{m}$  for the  $\text{Nb}_3\text{Sn}$  layers and 65  $\mu\text{m}$  for the Nb tubes. These values are in good agreement with the physical values that can be estimated from a backscatter electron micrograph of a reacted tube. A summary of these measurements was presented at the Magnet Technology Conference (MT'19) in Genova (EDMS 688570). This paper also exhibits experimental evidences that part of the large flux jumps observed on this wire may originate in the un-reacted Nb phase.

Data from the nano- and micro-hardness measurements have been analyzed and cross-checked with available literature data, yielding a summary table of relevant material properties (Young's modulus, yield strength, maximum elongation and ultimate tensile strength) in the cold work state of the wire at the end of drawing (EDMS 567375V1). In parallel, tensile tests have been carried out at CERN (EDMS 592009) and at the Bundesanstalt für Materialforschung (BAM), in Berlin, on samples of the old ITER-type wire while complementary nano-hardness measurements on longitudinal cuts of this wire have been subcontracted to EIAJ. Analyses of this second round of measurements led to an iteration on the table of material properties (EDMS 567375V2). This latter table presents provides a fairly consistent set of data that will be used in the FE model to study the behavior of two types of internal tin wires developed by Alstom/MSA: the old, ITER-type design and the new NED design (EDMS 575661).

#### JRA4.3.1 Work Package Coordination

As already mentioned, the CD Work Package is articulated around three main poles: conductor development (encompassing Tasks 3.2, 3.3, 3.4 and 3.6), conductor characterization (encompassing Tasks 3.5 and 3.7), and mechanical studies (extension of scope with respect to CARE Annex I, initiated by INFN-Ge and partially supported by CERN).

The conductor development pole was launched by D. Leroy (CERN) and is presently coordinated by L. Oberli (CERN). A working Group on Conductor Characterization (WGCC), chaired by A. den Ouden (TEU) has been set up to coordinate the conductor characterization efforts, while S. Farinon (INFN-Ge) is the principal investigator on the mechanical model.

The Pole Coordinators report to the NED Steering Committee and, ultimately, to the NED/JRA Coordinator.

### **JRA4.3.2 Design of a 15 T Dipole Magnet**

The following actions have been carried out:

- September 2003–July 2004: preliminary design computations carried out by O. Vincent-Viry (CERN) under D. Leroy supervision (CERN)
- November 2003: report on 2D magnetic induction analytical calculation issued by O. Vincent-Viry (CERN; EDMS 431540)
- January 2004 SC meeting: first presentation of preliminary design computations by O. Vincent-Viry (CERN)
- 4 May 2004: meeting at CEA to review magnetic configurations and choice of 88-mm-aperture,  $\cos\theta$  layer as Reference Design V1 (EDMS 555825)  
participants: H. Félice, L. Quettier, J.M. Riflet, P. Védrine (CEA), A. Devred (CEA&CERN), D. Leroy and O. Vincent-Viry (CERN)
- 2 August 2004: seminar at CERN by O. Vincent-Viry (CERN) on preliminary magnet designs
- 16 February 2005: first version of preliminary design report issued by D. Leroy and O. Vincent Viry (CERN; EDMS 555826)
- 26 July 2005: final version of preliminary design report issued by D. Leroy and O. Vincent Viry (CERN; EDMS 555826V2); EU deliverable

### **JRA4.3.3 Specifications on Wire and Cable**

The following actions have been carried out:

- 11 May 2004: first draft specification issued by D. Leroy (CERN) and communicated to A. Devred (CEA&CERN)
- 14 May 2004: first draft reviewed by A. Devred (CEA&CERN)
- 18 May 2004: second draft specification issued by D. Leroy and communicated to A. Devred (CEA&CERN) and A. den Ouden (TEU)
- 1 June 2004: third draft specification issued by D. Leroy and communicated to NED SC
- 4 June 2004: Specification Committee Meeting at CERN  
participants: T. Boutboul, P. Bryant (Chairman), P. Lebrun, D. Leroy, L. Oberli, L. Rossi (CERN), H.H.J. ten Kate (CERN&TEU)]
- 18 June 2004: final specification and technical questionnaire issued by D. Leroy (CERN; EDMS 475443); EU deliverable

### **JRA4.3.4 Wire Development**

The following actions have been carried out and/or are foreseen:

- 12 December 2003: preparatory visit to Alstom/MSA, France  
participants: A. Devred (CEA&CERN), D. Leroy, T. Boutboul and L. Oberli (CERN)]
- 15 December 2003: preparatory visit to European Advanced Superconductors (EAS, Germany)  
participants: A. Devred (CEA&CERN), D. Leroy and L. Oberli (CERN) + SMI representative
- 27 January 2004: preparatory visit to ShapeMetal Innovation (SMI, The Netherlands)  
participants: A. Devred (CEA&CERN), D. Leroy, T. Boutboul, and A. Unervick (CERN) + EAS representatives

- 21 June 2004: call for tender issued to Alstom/MSA, EAS, Outokumpu Copper (OK Cu, Finland), Outokumpu SI (OKSI, Italy) and SMI
- 20 August 2004: meeting at CERN with SMI and EAS to prepare answer to call for tender
- 23 August 2004: meeting at CERN with OK to prepare answer to call for tender
- 24 August 2004: meeting at CERN with Alstom/MSA to prepare answer to call for tender
- 6 September 2004: tenders' opening at CERN; selection of Alstom/MSA and SMI
- 24 September 2004: sending of orders to CERN Finance Division
- 15 November 2004: contracts' signature by Alstom/MSA and SMI
- 15 December 2004: first progress reports issued by Alstom/MSA and SMI (restricted access)
- 17 May 2005: visit of T. Boutboul, D. Leroy, L. Oberli (CERN) to Alstom/MSA
- 28 June 2005: visit of T. Boutboul, D. Leroy, L. Oberli (CERN) to SMI
- 14 September 2005: visit of T. Boutboul, L. Oberli (CERN) to Alstom/MSA
- 21 October 2005: meeting at Archamps to discuss progress of Alstom/MSA  
participants: T. Boutboul, L. Oberli (CERN) and C. Verwaerde (Alstom/MSA)
- 29 November 2005: visit of T. Boutboul, D. Leroy, L. Oberli (CERN) to Alstom/MSA
  - ⇒ December 2005: delivery of first batch of R&D wires from SMI (STEP1)
  - ⇒ First trimester of 2006: delivery of first batch of R&D wires from Alstom/MSA (STEP1)
  - ⇒ Summer/Fall 2006: delivery of second batch of R&D wires (STEP2)
  - ⇒ November/December 2006: final wire production; EU deliverable

### JRA4.3.5 Wire Characterization

The following actions have been carried out and/or are foreseen

#### *JRA4.3.5.1 Definition of Measurement Procedures*

- March 2004: setting up of Working Group on Conductor Characterization (WGCC), chaired by A. den Ouden (TEU)  
WGCC charges and composition: EDMS 548084
- 19 May 2004: first Working Group meeting at CERN  
participants: L. Quettier (CEA), V. Previtali (CERN), P. Fabbriatore and M. Greco (INFN-Ge), D. Pedrini, G. Volpini (INFN-Mi), A. den Ouden (TEU)  
Talks: EDMS 567255
- June 2004-October 2004: first round of test wires for cross-calibration purposes
- 28 October 2004: second Working Group meeting at CEA  
participants: L. Quettier (CEA), V. Previtali, T. Boutboul (CERN), M. Greco (INFN-Ge), D. Pedrini, G. Volpini (INFN-Mi), A. den Ouden (TEU)
- November 2004-January 2005: second round of test wires for cross-calibration purposes
- 22 February 2005: third Working Group meeting at INFN-Mi  
participants: L. Quettier (CEA), A. Devred (CEA&CERN), T. Boutboul and V. Previtali (CERN), M. Greco and P. Fabbriatore (INFN-Ge), D. Pedrini, G. Volpini (INFN-Mi)  
Talks and Minutes: EDMS 576267
- 3 May 2005: fourth Working Group Meeting at CERN  
participants: L. Quettier (CEA), T. Boutboul, D. Leroy, L. Oberli (CERN), M. Greco (INFN-GE), D. Pedrini, G. Volpini (INFN-Mi), A. den Ouden (TEU)  
Talks: EDMS 593632

- May-July 2005: third round of test wires for cross-calibration purposes (includes deformed wires by rolling)
- 22 November 2005: fifth Working Group Meeting at CERN  
participants: L. Quettier (CEA), A. Devred (CEA&CERN), T. Boutboul, L. Oberli V. Previtali (CERN), D. Pedrini (INFN-Mi), A. den Ouden (TEU)  
Talks: EDMS 682996
- 13 December 2005: final version of MT19 paper issued by A. den Ouden (TEU; EDMS 690009)
  - ⇒ December 2005-January 2006: final iteration on third round of cross calibration
  - ⇒ 28 February 2006: first interim report on wire characterization; EU milestone
  - ⇒ 31 December 2006: final report on wire characterization; EU deliverable

#### *JRA4.3.5.2 Wire IC Measurements at CEA*

⇒ June 2004-January 2006: cross-calibration program

#### *JRA4.3.5.3 Wire IC Measurements at INFN-Mi*

⇒ June 2004-January 2006: cross-calibration program

#### *JRA4.3.5.4 Wire IC Measurements at TEU*

⇒ June 2004-January 2006: cross-calibration program

#### *JRA4.3.5.5 Wire Magnetization Measurements at INFN-Ge*

- 21 January 2004: preparatory meeting at CERN  
participants: A. Devred (CEA&CERN), D. Leroy (CERN) and P. Fabbriatore (INFN-Ge]
- 23 March 2004: first report on preliminary measurements issued by P. Fabbriatore and M. Greco (INFN-Ge)
- 23 March 2004–13 April 2004: review of preliminary measurements by A. Devred (CEA&CERN) and D. Leroy (CERN)
- June 2004-July 2005 2005: participation to cross-calibration program defined by WGCC
- 23 November 2005: highlight talk given by M. Greco (INFN-Mi) at the CARE general meeting at CERN
- 5 December 2005: final version of MT19 paper issued by M. Greco (INFN-Mi; EDMS 688570)

#### **JRA4.3.6 Cable development and manufacturing**

*Not started*

#### **JRA4.3.7 Cable Characterization**

*Not started*

#### **JRA4.3.8 Mechanical Studies**

These studies are an extension of scope with respect to CARE Annex I and are supported by additional resources provided by INFN-Ge and CERN.

The following actions have been carried out and/or are foreseen:

- 28 January 2004: parameters of mechanical model for 19-subelement, internal tin wire issued by A. Devred (CEA&CERN; EDMS 548087)



- 30 January 2004: mesh proposal issued by S. Farinon (INFN-Ge)
- Early February 2004: review of mesh proposal by A. Devred (CEA&CERN), D. Leroy (CERN) and C. Verwaerde (Alstom/MSA)
- 25 March 2004: informal discussion of preliminary computation results
- participants: A. Devred (CEA), D. Leroy (CERN), S. Farinon (INFN-Ge), C. Verwaerde and P. Mocaer (Alstom/MSA)]
- 9 June 2004: meeting at CERN to review material properties and discuss computation results
  - participants: A. Devred (CEA&CERN), T. Boutboul, P. Fessia, D. Leroy and S. Sgobba (CERN), S. Farinon and R. Musenich (INFN-Ge), P. Loverage (CCLRC)
- 7 July 2004: meeting at CERN to review material properties and discuss computation results
  - participants: A. Devred (CEA&CERN), T. Boutboul, P. Fessia, L. Oberli M. Pojer and S. Sgobba (CERN), P. Fabbriatore and S. Farinon (INFN-Ge)
- September 2004: first contract issued to EIAJ to perform nano-indentation measurements on an un-reacted, internal-tin wire cross-section
- 14 October 2004: visit to EIAJ, Le Locle (CH)
  - participants: T. Boutboul, C. Scheuerlein, S. Sgobba (CERN)
  - trip report: EDMS 520095
- 29 October 2004: first report issued by EIAJ on nano-indentation measurements (EDMS 548100)
- 11 November 2004: meeting at CERN to review nano-indentation measurements performed at EIAJ
  - participants: A. Devred (CEA&CERN), T. Boutboul, P. Fessia, D. Leroy, L. Oberli, V. Previtali, D. Richter and S. Sgobba (CERN), P. Fabbriatore and S. Farinon (INFN-Ge)
- 11 November 2004: first report issued by C. Scheuerlein (CERN) on micro-hardness measurements at CERN (EDMS 548116)
- 22 November 2004: meeting at CERN to review micro-hardness measurements
  - participants: A. Devred (CEA&CERN), T. Boutboul, C. Scheuerlein, S. Sgobba and W. Scandale (CERN)
- 15 February 2005: second report issued by C. Scheuerlein (CERN) on micro-hardness measurements at CERN (EDMS 567297)
- 15 February 2005: meeting at CERN to update table of material properties to be used in FE model
  - participants: A. Devred (CEA&CERN), T. Boutboul, D. Leroy, C. Scheuerlein, S. Sgobba (CERN)
- 17 February 2005: report issued by T. Boutboul (CERN) on RRR measurements at CERN (EDMS 567365)
- 22 February 2005: table of material properties issued by S. Sgobba and C. Scheuerlein (CERN; EDMS 567375)
- 23 March 2005: note issued by T. Boutboul and L. Oberli (CERN) defining new parameters of internal tin wire (EDMS 575661)
- April 2005: second contract issued to EIAJ to perform nano-indentation measurements on a longitudinal cross-section of an un-reacted, internal-tin wire
- 9 May 2005: first version of report on UTS measurements at CERN issued by C. Scheuerlein (CERN; EDMS 567375)
- 6 June 2005: second version of report on UTS measurements at CERN issued by C. Scheuerlein (CERN; EDMS 567375V2)
- 6 October 2005: meeting at CERN to discuss results of tensile tests performed at BAM

- participants: A. Devred (CEA&CERN), T.Boutboul, L. Oberli, C. Scheuerlein (CERN)
- 10 November 2005: visit of C. Scheuerlein to BAM (CERN; EDMS 681910)
- 11 November 2005: meeting at CERN to update Table of material properties (CERN; EDMS 567375V2)
  - participants: L. Oberli, C. Scheuerlein, S. Sgobba (CERN)
- 24 November 2005: meeting at CERN to discuss problems with FE modelling in the plastic range
  - participants: A. Desirelli and S. Sgobba (CERN), S. Farinon (INFN-Mi)
- 9 December 2005: report on “room temperature tensile properties of the powder-in-tube (PIT) Nb<sub>3</sub>Sn strand SMI B201 for NED” issued by C. Scheuerlein (CERN; EDMS 688862)

### JRA4.3.9 Overall Progress of Work Package 3

The following table highlights the progress of work planned in the year 2005 for the work package WP3 by listing the lowest level subtasks of the NED detailed implementation plan.

WP3	Title	Original begin date	Original end date	Estimated Status	Revised end date
3.1	CD WP Coordination				
3.2	Design of a 15 T Dipole Magnet	1 Jan. 2004	31 Dec. 2004	Completed	Jul. 2005
3.3	Specifications on Wire and Cable	1 Apr. 2004	30 Jun. 2004	Completed	On time
3.4	Wire Development	1 Jul. 2004	30 Jun. 2006	Started	30 Sept. 2006
3.5	Wire Characterization				
3.5.1	Definition of Measuring Procedures	1 Jan. 2004	30 Jun. 2005	80%	28 Feb. 2006
3.5.2	Ic measurements at CEA	1 Jul. 2005	30 Jun. 2006	Started	31 Dec. 2006
3.5.3	Ic measurements at INFN-Mi	1 Jul. 2005	30 Jun. 2006	Started	31 Dec. 2006
3.5.4	Ic measurements at TEU	1 Jul. 2005	30 Jun. 2006	Started	31 Dec. 2006
3.5.5	Wire Magnetization Measurements	1 Jul. 2005	30 Jun. 2006	Started	31 Dec. 2006
3.6	Cable Development	1 Jul. 2005	31 Dec. 2006	Not started	15 Dec. 2006
3.7	Cable Characterization	1 Oct. 2005	31 Dec. 2006	Not started	-
3.8	Mechanical Studies <sup>a)</sup>	1 Jan. 2004	31 Dec. 2005	40%	30 Jun. 2006

<sup>a)</sup> Extension of scope with respect to CARE Annex I.

## **JRA4.4 Work Package 4: Insulation Development & Implementation (IDI)**

Work Package 4 includes two main Tasks:

- conventional insulation development  
(carried out by CCLRC/RAL, Task Leader: S. Canfer)
- innovative insulation development  
(carried out by CEA, Taks Leader: F. Rondeaux)

### **2004 Summary**

CCLRC and CEA have written an engineering specification for the NED conductor insulation (EDMS 548037) and a coordinated Test Programme for the conventional and innovative insulations (EDMS 548038).

CCLRC has started investigations on glass fiber sizings and epoxy resin fillers and is developing an experimental set up to perform fracture tests based on a double-cantilever beam (DCB).

The start of the work on Innovative Insulation at CEA (Task 4.4) has been delayed, pending the hiring of a technician to support the activity of the chemistry laboratory.

### **2005 Summary**

Screening testing of candidate materials for Conventional Insulation has progressed well. CCLRC has developed a standardised laminate production system and relies on three tests for screening: (1) inter-laminar fracture test, (2) short-beam shear test and (3) electrical breakdown test. The standard laminates leave sufficient material for radiation testing.

To gain experience and validate the inter-laminar fracture tests, three know systems of epoxy resins have been investigated: (1) a brittle system made up of DGEBA resin with an acid anhydride hardener (HY918, Ciba), (2) a tough system, made up of DGEBA resin with an aliphatic amine hardener (Jeffamine D-400), and (3) an intermediary system, made up of DGEBF resin, a PPGDGE flexibiliser and an aromatic amine hardener (HY5200, Ciba). All samples were prepared using as received E-glass tapes with commercial sizing, and the tests were performed at room temperature and at 77 K. As expected, the brittle system yields the lowest work of fracture ( $\sim 0.45 \text{ kJ/m}^2$  at room temperature), while the toughest system yields the highest one ( $\sim 1 \text{ kJ/m}^2$  at room temperature), and the intermediary system is in between ( $\sim 0.8 \text{ kJ/m}^2$  at room temperature). The results are in the same order, but 20 to 40% higher at 77 K.

Furthermore, CCLRC has investigated the issue of fibre glass sizing. The sizing that coats the filaments of commercial fibre tapes is a mixture of organic materials that is not intended for high temperature use, and, if left in place, can result in undesirable carbon residues at the end of the  $\text{Nb}_3\text{Sn}$  reaction cycle. In practice, the sizing is removed from the tapes (by carbonization in air at temperatures in the 350-450 °C range) prior to conductor wrapping and winding. However, removing the sizing renders the tape fragile and easy to tear off by friction, which complicates the manufacturing process. In addition, sizing removal has proved to have a bearing on the mechanical and electrical performances of the final insulation system. CCLRC has identified an improved sizing material, which is a commercial polyimide produced by Hydrosize, NC, USA that may sustain the  $\text{Nb}_3\text{Sn}$  reaction cycle without deleterious degradation. This sizing has been applied to glass and quartz fibre fabric by JPS Glass, SC, USA.

To assess the suitability of the polyimide sizing, CCLRC has undertaken a comparative test on standard laminates made up of conventional S-glass tapes (as received, de-sized and heat treated for 60 hours at 660 °C in a vacuum after de-sizing) and of polyimide-sized, S-glass and quartz fabrics provided by JPS (as received and heat-treated for 60 hours at 660 °C in a vacuum without de-sizing). The laminates were vacuum-impregnated with a system made up of DGBEF resin (DER354P, Dow) and a DETDA hardener (HY5200, Vantico). (This system was chosen because it is both relatively radiation stable and has a low viscosity, and, thereby, seems the best suited to NED application). The work of fracture measured on the conventional, as-received, S-glass sample is 0.49 kJ/m<sup>2</sup> at room temperature, which puts the resin system into the brittle category (not unexpected given the nature of the hardener that was chosen). No meaningful work of fracture could be measured on the conventional, de-sized, heat-treated, S-glass sample. Indeed, the sample failed through the glass layer and not in an inter-laminar fashion, thereby indicating that the glass was adversely affected by heat treatment. The results on the polyimide-sized, S-glass samples are very promising: the work of fracture on the sample made up of as-received fabric is 0.7 kJ/m<sup>2</sup> at room temperature and stays at 0.67 kJ/m<sup>2</sup> on the sample made up of heat-treated fabric. The short-beam shear strengths measured at 77 K are above ~90 MPa for all samples, save for the conventional, de-sized, heat-treated, S-glass sample where it falls to 69 MPa. Finally, electrical breakdown tests were carried out on conventional, heat-treated, de-sized and not de-sized S-glass samples and on heat-treated, polyimide-sized S-glass samples. The voltage measured on the conventional, de-sized sample and on the polyimide-sized sample are both in excess of 30 kV/mm, while the one measured on the sample made up of conventional S glass, heat-treated without de-sizing, is degraded to 2.5 kV/mm. Preliminary results on this sub-task have been reported in a paper presented at ICMC2005 in Keystone, CO (EDM 685456)

The work on the Innovative Insulation is still on hold pending the hiring of a technician in the chemistry lab at CEA, which has been further delayed until the end of 2005. To compensate this delay, it has been decided to re-allocate part of the EU funding to hire a postdoc at CEA.

#### **JRA4.4.1 Work Package Coordination**

The IDI Work Package is coordinated by E. Baynham (CCLRC). The conventional Insulation Task (4.3) is headed by S. Canfer (CCLRC) while the Innovative Insulation Task (4.4) is headed by F. Rondeaux (CEA). The Work Package and Task Leaders report to the NED Steering Committee and, ultimately, to the NED/JRA Coordinator.

#### **JRA4.4.2 Specification Drafting**

The following actions have been carried out:

- 6 May 2004: draft specifications issued by S. Canfer (CCLRC)
- 11 May 2004: conference call on insulation specifications  
participants: S. Canfer and J. Greenhalgh (CCLRC), F. Rondeaux (CEA), A. Devred (CEA&CERN), A. den Ouden (TEU)
- 11 May 2004: Version 2 of specifications issued by S. Canfer (CCLRC; EDMS 548037V1)
- 25 May 2004: Version 2.2 of specifications issued by S. Canfer (CCLRC; EDMS 548037V2)
- 1 June 2004: Version 2.3 of specifications issued by S. Canfer (CCLRC; EDMS 548037V3)
- 23 June 2004: Version 2.3b of specifications issued by S. Canfer (CCLRC; EDMS 548037V4)
- 16 July 2004: final specifications (EDMS 548037V5); EU milestone

**JRA4.4.3 Conventional Insulation**

The following actions have been carried out and/or are foreseen:

- 27 July 2004: first draft of conventional insulation Test Programme (EDMS 548038V1)
- 12 August 2004: second draft of conventional insulation Test Programme
- 27 October 2004: final insulation Test Programme (including Test Programme for innovative insulation; EDMS 548038V2); EU milestone
- 30 September 2004: completion of Literature Survey (Sub-Task 4.3.1)
- 30 November 2004: completion of Tooling Preparation (Sub-Task 4.3.2)
- 31 December 2004: completion of Component Supply (Sub-Task 4.3.3)
  - ⇒ 1 January 2005 – 30 September 2005: Iterative Tests (Sub-Task 4.3.4)
  - ⇒ 1 October 2005 – 31 December 2005: Data Analysis (Sub-Task 4.3.5)
  - ⇒ 1 July 2005 – 30 June 2006: Irradiation Tests (extension of scope with respect to CARE Annex I)
  - ⇒ 30 June 2006: final report on conventional insulation; EU deliverable

**JRA4.4.4 Innovative Insulation**

The following actions have been carried out and/or are foreseen

- 6 May 2004: preparatory meeting at CEA  
participants: J.M. Rifflet, F. Rondeaux and P. Védrine (CEA), A. Devred (CEA&CERN); conclusions of this meeting are reported above
- 30 August 2004: first draft of innovative insulation Test Programme
- September 2004: final innovative insulation Test Programme (added to EU milestone on conventional insulation Test Programme)
  - ⇒ 1 January 2005 – 31 December 2005: Tape Weaving Trial (Sub-Task 4.4.1)
  - ⇒ 1 January 2005 – 30 June 2006: Characterization Tests (Sub-Task 4.4.2; scope has been modified with respect to CARE Annex I)
  - ⇒ 30 June 2006: final report on innovative insulation; EU deliverable

**JRA4.4.5 Overall Progress of Work Package 4**

The following table highlights the progress of work planned in the year 2005 for the work package WP4 by listing the lowest level subtasks of the NED detailed implementation plan.

WP4	Title	Original begin date	Original end date	Estimated Status	Revised end date
4.1	IDI WP Coordination				
4.2	Specifications' Drafting	1 Apr. 2004	30 Jun. 2004	Completed	22 Jul. 2004
4.3	Conventional Insulation				
4.3.1	Literature Survey	1 Jul. 2004	30 Sept. 2004	Completed	On time
4.3.2	Tooling Preparation	1 Oct. 2004	30 Oct. 2004	Completed	31 Dec. 2005
4.3.3	Component Supply	1 Oct. 2004	31 Dec. 2004	Completed	On time
4.3.4	Iterative Tests	1 Jan. 2005	30 Sept. 2005	75%	31 Mar. 2006
4.3.5	Data Analysis	1 Oct. 2005	31 Dec. 2005	Not started	-
4.3.6	Irradiation tests <sup>a)</sup>	1 Jul. 2005	30 Jun. 2006	Not started	-
4.4	Innovative Insulation				
4.4.1	Tape Weaving Trial	1 Jul. 2004	31 Dec. 2004	Not started	30 Jun. 2006
4.4.2	Characterization Tests <sup>b)</sup>	1 Jul. 2004	30 Jun. 2005	Not started	31 Dec. 2006

<sup>a)</sup> Extension of scope with respect to CARE Annex I.

<sup>b)</sup> Modification of scope with respect to CARE Annex I.

## JRA4.5 Working Group Magnet Design and Optimisation

### 2004 Summary

CCLRC, CEA, CERN and CIEMAT have decided to join forces in order to create an informal Working Group on Magnet Design and Optimization (WGMDO), whose charges and composition are defined in EDMS 547882.

The Working Group is made up of

- H. Félice (CEA)
- P. Fessia (CERN)
- P. Loveridge (CCLRC)
- J. Rochford (CCLRC)
- S. Sanz (CIEMAT)
- F. Toral-Fernandez (CIEMAT), Technical Secretary
- P. Védrine (CEA), Chairman

This Working Group is an extension of scope with respect to CARE Annex 1. It is supported by CCLRC (whose contribution foreseen to Task 3.2 has been shifted to this end) and by additional resources from CEA, CERN and CIEMAT.

The Working Group has agreed on a common set of high-field-dipole-magnet design parameters (EDMS 547884) and on a common set of material properties, such as iron yoke  $B$ - $H$  curve (EDMS 555825) and Young's moduli and integrated thermal expansion coefficients (EDMS 683000V5). Then, it has selected a number of magnetic configurations to be studied and compared, which include:

- the conventional,  $\cos\theta$ , layer design,
- Pérot's  $\cos\theta$ , slot design,
- a so-called ellipse-*type* design proposed by CEA,
- a so called *motor-type* design proposed by CIEMAT,
- the twin-*aperture*, common-coil design, first proposed by G. Danby at Brookhaven National Laboratory (BNL) in 1983 and subsequently resuscitated by R. Gupta in 1996,
- the *double-helix* or helical dipole design first investigated in the 1970's.

The comparison will be carried out in three steps: (1) comparison of 2-D electromagnetic designs, (2) comparison of 2-D mechanical designs and (3) comparison of 3-D designs. Each partner has chosen one or two configurations and has started to work on 2-D electromagnetic and mechanical designs.

### 2005 Summary

CCLRC/RAL has chosen to investigate the Reference Design V1,  $\cos\theta$ , layer design and to assess the feasibility of a double-helix magnetic configuration. The  $\cos\theta$  optimization was carried out using software supplied by the commercial company Vector Fields, which has close links with the RAL magnet group. At first, the software was used to construct a 2D parameterized FE model, which includes the option of modeling the nonlinear effects of iron and a non-uniform current density in the conductor winding (as generated by the slightly-keystoned, NED Rutherford-type cable). A number of test cases were run to check the optimizer provided by Vector Fields and to look at the effects of changing the objective functions. The output from the full model has now been compared with ROXIE and it gives the same results for the same geometry and field. Investigations are being carried out to determine whether the optimizer routines from both packages yield the same solutions, given the same starting point. The work on the helical dipole configuration has just begun and a basic model capable of being used with the VF optimizer has been built and is ready to run.



In parallel, CCLRC/RAL has started the development of a 2D mechanical model of NED Reference Design V1 based on ANSYS<sup>®</sup>. The model is in two steps. The first step includes the coil assembly, the ground plane insulation, pairs of austenitic steel collars and keys. It is used to simulate the collaring process during which the collars are implemented around the insulated coil assembly and are clamped by means of the keys to pre-compress the coil azimuthally. The second step includes the aforementioned collared-coil assembly completed by a two-piece, horizontally-split, iron yoke and a welded outer shell that holds the coldmass together. The two yoke halves are assembled around the collared-coil assembly in such way that there remains a gap at their midplane. The room-temperature coil pre-compression after collaring and the yoke midplane gap after shell welding must be optimized to ensure that, when the magnet is cold and energized, the coil remains under compression and the yoke midplane gap is closed, thereby providing a very stiff support against the Lorentz force. The first step of the model is now fully operational, while the details of the second step are being worked out.

CEA has been working on an original design referred to as *ellipse-type*, and has carried out 2D electromagnetic analyses of 88-mm-, 130-mm- and 160-mm-aperture models using ROXIE. It has been shown that, in each case, accelerator-field quality can be reached by optimizing the conductor distribution and that the peak-to-central-field ratio is very advantageous. Nevertheless, the Lorentz forces involved are huge a lot of attention has to be paid to the mechanical design. CEA is presently developing a mechanical model of the 130-mm-aperture design based on CASTEM.

In parallel, and at the margin of the WGMDO efforts, CEA has been subcontracted by EFDA to study a 130-mm-aperture, 12.5-central-field, dipole magnet relying on a conventional  $\cos\theta$ , layer design. The preliminary mechanical analysis carried out as part of this study concludes that the Lorentz stresses originating in the coils are excessive and that there is no easy way to control and limit them. This may indicate that such a field level in such an aperture is out of reach for the conventional  $\cos\theta$ , layer design and that one needs to rely on a different magnetic configuration.

CERN has pursued the 2D electromagnetic optimization of Reference Design V1 with ROXIE. The optimization was carried out with respect to

- *conductor* geometry (to minimize all multipole coefficients and improve radial positioning of conductor blocks in 2D cross-section),
- shape of iron yoke inner boundary (to minimize saturation effects),
- size and implementation of ferromagnetic shims (to compensate superconductor magnetization effects).

The re-optimization is now completed and has led to the definition of a new reference design, referred to as Reference Design V2 (EDMS 692145), with a good field quality (all multipole coefficients are below 1 unit at a reference radius of 29 mm, save for the normal 18-pole,  $b_9$ , which is equal to 1.7 unit and the normal 22-pole,  $b_{11}$ , which is equal to 2.7 unit), efficient peak-to-central field ratio ( $\sim 1.03$  to 1), 15.0 T conductor peak field for a quench current of 29.4 kA and a more radial conductor distribution.

Regarding iron saturation, computations were carried out for the conductor distribution of Reference Design V2 and two different yoke configurations: one with a circular inner boundary (with an inner radius of 125.4 mm) and one with an optimized, elliptical inner boundary (with a vertical, half major axis of 136.6 mm and an horizontal, half minor axis of 125.4 mm). Relying on an elliptical inner boundary enables one to reduce the  $b_3$  peak-to-peak variations by a factor  $\sim 3$ .

Regarding superconductor magnetization, computations were carried out either computed when taking into account the full effect (no corrective shims) and or when introducing two ferromagnetic shims at suitable locations inside the coils: one 1.5-mm-thick shim attached right below the upper wedge of the outer layer and one 0.7-mm-thick shim attached right below the middle wedge of the inner layer. The effects of persistent magnetization currents were estimated using a ROXIE feature which combines a vector hysteresis model for hard superconductors with the BEM-FEM method and which relies on a given  $J_C(B)$  fit function for the superconducting filaments. The  $J_C(B)$  function used in the simulation was extracted from magnetization measurements performed by Twente University on an existing 0.9-mm-diameter, 504-filament PIT wire, produced by SMI in 2000, appropriately rescaled to NED specifications (in particular, with respect to the non-copper critical current density of  $3000 \text{ A/mm}^2$  at 4.2 K and 12 T and to the effective filament outer diameter of  $50 \mu\text{m}$ ; EDMS 638344). The introduction of the two ferromagnetic shims enables one to reduce the  $b_3$  variations during the up-ramp (lower part of the hysteresis curves) by a factor in excess of 3. These encouraging results show that the selected correction schemes can be quite effective (at least on the normal sextupole coefficient,  $b_3$ ), and that we do have some means of compensating the effects of both iron saturation and superconductor magnetization.

CIEMAT has worked on the 2D electromagnetic analysis of the 88-mm- and 130-mm-aperture motor-type design and of the 88-mm-aperture common-coil design using ROXIE. Starting from the set of design parameters agreed upon by the Working Group, the field quality has been optimized in the cross-section while keeping an eye on the feasibility of the mechanical design and on the Lorentz forces to be handled. For both configurations, the number of design variables is enough to get an optimum field quality, as well as a good peak-to-central field ratio. However, the motor-type design appears to yield a high fringe field while calling for a large superconductor volume.

The following actions have been carried and/or are foreseen:

- 19 May 2004: brainstorming session at CEA/Saclay  
participants: H. Felice, L. Quettier and P. Védérine (CEA), A. Devred, (CEA&CERN), P. Fessia (CERN), S. Sanz and F. Toral (CIEMAT), P. Loveridge and J. Rochford (CCLRC)  
preparatory document: EDMS 547883  
minutes: EDMS 547884
- 23 November 2004: meeting at CERN to discuss CCLRC computations on NED baseline (88-mm-aperture,  $\cos\theta$ , layer) design  
participants: D.E. Baynham and P. Loveridge (CCLRC), A. Devred, (CEA&CERN), D. Leroy (CERN)
- 17 December 2004: WGMDO meeting at CIEMAT to review 2-D magnetic designs  
participants: P. Loveridge, J. Rochford (CCLRC), H. Felice, P. Védérine (CEA), A. Devred (CEA&CERN), S. Sanz, F. Toral (CIEMAT)  
talks and minutes: EDMS 547885
- 27 January 2005: visit of P. Loveridge (CCLRC) to CEA to discuss FE modelling  
participants: P. Loveridge (CCLRC), M. Ségréti and P. Védérine (CEA), A. Devred (CEA&CERN)
- 13 April 2005: meeting at CERN to discuss CCLRC progress on ANSYS model of NED Reference Design V1  
participants: E. Baynham, P. Loveridge (CCLRC), A. Devred (CEA&CERN), P. Fessia and M. Pojer (CERN)
- 13 April 2005: WGMDO meeting at CERN

participants: E. Baynham, P. Loveridge, J. Rochford (CCLRC), H. Félice (CEA), A. Devred (CEA&CERN), P. Fessia, N. Schwerg (CERN), S. Sanz and F. Toral (CIEMAT)

talks and minutes: EDMS 581911

- 14 June 2005: WGMDO meeting at CCLRC to review progress on 2-D magnetic and mechanical designs  
participants: E. Baynham, S. Canfer, C. Densham, J. Greenhalgh, P. Loveridge, J. Rochford, (CCLRC), H. Félice (CEA), A. Devred (CEA&CERN), N. Schwerg (CERN), S. Sanz and F. Toral (CIEMAT)  
talks and minutes: EDMS 600861
- 23 June 2005: meeting at CERN to discuss CCLRC progress on ANSYS model of NED Reference Design V1  
participants: E. Baynham (CCLRC/RAL), A. Devred (CEA&CERN) and D. Leroy (CERN)
- 1 September 2005: start date of Federico Regis at CERN, as unpaid associate supported by a Associazione Sviluppo Tecnologico e Scientifico Piemonte (ASP) grant, to work on NED mechanical design under the supervision of P. Fessia (CERN)
- 27 September 2005: CERN/AT/MAS seminar of N. Schwerg (CERN) on “Optimization of the coil cross section for NED”
- 6 October 2005: meeting at CERN to discuss CCLRC progress on ANSYS model of NED Reference Design V1  
Participants: E. Baynham, P.Loveridge (CCLRC/RAL), A. Devred (CEA&CERN), D. Leroy (CERN)
- 21 November 2005: Version 4 of Table of material properties issued by P. Loveridge (CCLRC/RAL; EDMS 683000V4)
- 22 November 2005: WGMDO meeting at CERN to review progress on 2-D magnetic and mechanical designs  
participants: P. Loveridge, (CCLRC), H. Félice (CEA), A. Devred (CEA&CERN), B. Auchmann, P. Fessia. D. Leroy, M. Pojer, F. Regis S. Russenschuck (CERN), S. Sanz and F. Toral (CIEMAT), A. den Ouden (TEU)  
agenda and talks: EDMS 682994
- 16 December 2005: Version 5 of Table of material properties issued by P. Loveridge (CCLRC/RAL; EDMS 683000V5)

#### **JRA4.6 Significant Achievements**

- Manufacturing and reception tests of double-bath, HeII cryostat for heat transfer measurements.
- Detailed computations of thermo-electrical behaviour of NED-like magnets during a quench.
- Assembly of first round of billets for NED conductor production at Alstom/MSA and SMI.
- Identification of a polyimide-sized, glass fiber tape candidate for conventional conductor insulation.
- Iterated design of an 88 mm aperture 15 T dipole magnet (NED Reference Design V2).

**JRA4.7 List of all milestones and deliverables (D) during the reporting period**

WP	Title	Responsible Lab(s)	Due date in Annex 1	Status	Revised delivery date
2.2.4	Report on Heat Transfer Facility Commissioning (deliverable)	CEA and WUT	1 Apr. 2005	Not started	31 Jan. 2006
2.2.5	Interim Report on Heat Transfer Measurements (milestone)	CEA	31 Dec. 2005	Not started	30 Jun. 2006
2.2.5	Final Report on Heat Transfer Measurements (deliverable)	CEA	31 Dec. 2006	Not started	-
2.3	Interim Report on Quench Protection (milestone)	INFN-Mi	31 Dec. 2004	Completed	13 Apr. 2005
2.3	Final Report on Quench Protection (deliverable)	INFN-Mi	30 Jun. 2005	Ongoing	31 Dec. 2005
3.2	Design Report (deliverable)	CERN	31 Dec. 2004	Completed	Jul. 2005
3.3	Final Report on Wire and Cable Specifications (deliverable)	CERN	30 Jun. 2004	Completed	On time
3.4	Progress Report on Wire Development (milestone)	CERN	30 Jun. 2005 <sup>a)</sup>	Completed Ongoing	15 Dec. 2004 31 Dec. 2005
3.4	Production of Final Wire (deliverable)	CERN	30 Jun. 2006	Not started	15 Dec. 2006
3.5	Intermediate Results on Wire Characterization (milestone)	CEA, INFN-Ge, INFN-Mi, TEU	31 Dec. 2005	Started	28 Feb. 2006
3.5	Final Report on Wire Characterization (deliverable)	CEA, INFN-Ge, INFN-Mi, TEU	30 Jun. 2006	Not started	31 Dec. 2006
3.6	Production of Final Cable (deliverable)	CERN	31 Dec. 2006	Not started	-
3.7	Final Report on Cable Performances (deliverable)	TEU	31 Dec. 2006	Not started	-
4.2	Report on Specifications for Conductor Insulation (milestone)	CCLRC	30 Jun. 2004	Completed	22 Jul. 2004
4.3&4.4	Report on Definition of the Test Programme (milestone) <sup>b)</sup>	CCLRC&CEA	31 Jul. 2004	Completed	27 October 2004
4.3	Report on Conventional Insulation (deliverable)	CCLRC	31 Dec. 2005	Not started	30 Jun. 2006
4.4	Report on Innovative Insulation (deliverable)	CEA	30 Jun. 2005	Not started	31 Dec. 2006

a) The CARE Annex I milestone entitled "First Results on Wire Development" that was due on 30 June 2005 has been split into three "Status Reports" due on 15 Dec. 2004 and 31 Dec. 2005.

b) Scope of report has been extended to include test programme on innovative insulation (Task 4.4)

**JRA4.8 List of major meetings organized under NED during the reporting period**

<b>Date</b>	<b>Title /Subject</b>	<b>Location</b>	<b>Number of attendees</b>	<b>Web Site address</b>
Jan 20	NED SC	CERN	22	<a href="http://lt.tnw.utwente.nl/project.php?projectid=9">http://lt.tnw.utwente.nl/project.php?projectid=9</a>
Feb 2	NED WGCC	LASA	6	<a href="http://lt.tnw.utwente.nl/project.php?projectid=9">http://lt.tnw.utwente.nl/project.php?projectid=9</a>
Apr 13	NED WGMDO	CERN	8	<a href="http://lt.tnw.utwente.nl/project.php?projectid=9">http://lt.tnw.utwente.nl/project.php?projectid=9</a>
Apr 14	NED SC	CERN	18	<a href="http://lt.tnw.utwente.nl/project.php?projectid=9">http://lt.tnw.utwente.nl/project.php?projectid=9</a>
May 3	NED WGCC	CERN	8	<a href="http://lt.tnw.utwente.nl/project.php?projectid=9">http://lt.tnw.utwente.nl/project.php?projectid=9</a>
Jun 14	NED WGMDO	CCLRC	11	<a href="http://lt.tnw.utwente.nl/project.php?projectid=9">http://lt.tnw.utwente.nl/project.php?projectid=9</a>
Jul 7	NED SC	WUT	14	<a href="http://lt.tnw.utwente.nl/project.php?projectid=9">http://lt.tnw.utwente.nl/project.php?projectid=9</a>
Nov 22	NED WGCC	CERN	7	<a href="http://lt.tnw.utwente.nl/project.php?projectid=9">http://lt.tnw.utwente.nl/project.php?projectid=9</a>
Nov 22	NED WGMDO	CERN	12	<a href="http://lt.tnw.utwente.nl/project.php?projectid=9">http://lt.tnw.utwente.nl/project.php?projectid=9</a>
Nov 24	NED SC	CERN	26	<a href="http://lt.tnw.utwente.nl/project.php?projectid=9">http://lt.tnw.utwente.nl/project.php?projectid=9</a>

## 2. List of deliverables

2004

Activity	Deliverable N°	Deliverable Name	Deliverable Type	Workpackage/ Task N°	Delivered by Contractor (s)	Planned (in months)	Achieved (in months)
<b>ELAN</b>	1	ELAN web site	<a href="#">Web site</a>	All WPs	CNRS-Orsay	4	4
<b>ELAN</b>	2	Beam Dynamics code repository site functional	<a href="#">Data base</a>	WP3	CERN	12	12
<b>ELAN</b>	3	Instrumentation web site	<a href="#">Web site</a>	WP4	CCLRC, UMA	6	21
<b>ELAN</b>	4	Instrumentation data base	<a href="#">Data base</a>	WP4	CCLRC, UMA	12	23
<b>BENE</b>	5	BENE web site	<a href="#">Web site</a>	All WPs	INFN-Na	4	4
<b>BENE</b>	6	Annual report of the BENE network	<a href="#">Report</a>	All WPs	INFN-Na	12	12
<b>BENE</b>	7	Proposal for FP6 Design Study of a new neutrino facility	Report	All WPs	INFN-Na	12	delayed to FP7
<b>BENE</b>	8	Proceedings of Multi-MW workshop	<a href="#">Report</a>	All WPs	INFN-Na	12	14
<b>BENE</b>	9	BENE Physics web site	<a href="#">Web site</a>	WP1	INFN-Pa, CERN	3	3
<b>HHH</b>	10	HHH web site	<a href="#">Web site</a>	All WPs	CERN	12	9
<b>HHH</b>	11	APD web site	<a href="#">Web site</a>	WP3	CERN	6	9
<b>SRF</b>	12	Final report on reliability issues	Report	WP2	DESY	9	Delayed, 30
<b>SRF</b>	13	EP on samples: best EP parameters	<a href="#">Report</a>	WP5	CEA	12	26
<b>NED</b>	14	Final report on wire and cable specifications	<a href="#">Report</a>	WP3	CERN	6	6
<b>NED</b>	15	Design report on 15 T dipole magnet	<a href="#">Report</a>	WP3	CERN	12	13



## 2005

Activity	Deliverable N°	Deliverable Name	Deliverable Type	Workpackage/ Task N°	Delivered by Contractor (s)	Planned (in months)	Achieved (in months)
<b>ELAN</b>	1	Work plan and documentation data base	<a href="#">Data base</a>	WP1	CERN	24	22
<b>ELAN</b>	2	Data base on SRF documents	<a href="#">Data base</a>	WP2	DESY	24	24, 70% final
<b>BENE</b>	3	18-month interim report	<a href="#">Report</a>	All WPs	INFN-Na	23	23
<b>BENE</b>	4	Annual report of the BENE network	<a href="#">Report</a>	All WPs	INFN-Na	24	24
<b>BENE</b>	5	Proceedings of NuFact'05 workshop	Report	All WPs	INFN-Na	24	27, sent to publisher
<b>BENE</b>	6	Launch of scoping study of a new neutrino facility	<a href="#">Web site</a> <a href="#">Report</a>	All WPs	INFN-Na	18	18
<b>HHH</b>	7	Beam Dynamics code repository	<a href="#">Data base</a>	WP3	CERN	24	18
<b>SRF</b>	8	EP on multi-cells: parameters fixed	Report	WP5	DESY	13	delayed, 27
<b>SRF</b>	9	Automated EP is defined	Report	WP5	INFN-Legnaro	21	delayed, 26
<b>SRF</b>	10	Dry ice cleaning: parameters fixed	Report	WP5	DESY	18	delayed, 30
<b>SRF</b>	11	CEA tuner: start of integrated experiments	<a href="#">Prototype</a>	WP8	CEA	15	24
<b>SRF</b>	12	Report on IN2P3 tuner activities	Report	WP8	CNRS-Orsay	24	delayed, 32
<b>SRF</b>	13	Report on data management developments	<a href="#">Report</a>	WP9	DESY	21	24
<b>SRF</b>	14	Report on RF gun control tests	Report	WP9	DESY	23	delayed, 34
<b>PHIN</b>	15	High efficiency photocathode comparison	Report	WP2	FZR	24	24
<b>PHIN</b>	16	High power laser oscillator	<a href="#">Report</a>	WP3	CCLRC-RAL	13	13

A. ACTIVITY REPORT

<b>PHIN</b>	17	Amplifier construction	Prototype	WP3	CCLRC-RAL	19	19
<b>PHIN</b>	18	Oscillator + amplifier test	Report	WP3	CCLRC-RAL	23	delayed, 27
<b>PHIN</b>	19	Pulse shaping system: phase mask acquisition and test	<a href="#">Report</a>	WP3	INFN-Milano	16	23
<b>PHIN</b>	20	Pulse shaping system: Dazzler acquisition and test	Report	WP3	INFN-LNF	17	17
<b>PHIN</b>	21	Pulse shaping comparison	Prototype	WP3	INFN-LNF, INFN-Milano	22	22
<b>PHIN</b>	22	UV harmonic generator test	Prototype	WP3	CCLRC-RAL	16	delayed, 30
<b>PHIN</b>	23	Laser RF feedback development	Report	WP3	CERN	21	21
<b>PHIN</b>	24	Two 3 GHz RF guns construction	Prototype	WP4	CNRS-Orsay	18	delayed, 32
<b>PHIN</b>	25	1-50 MeV spectrometer construction	Prototype	WP4	CNRS-LOA	24	24
<b>HIPPI</b>	26	Halo measurement device design and construction	<a href="#">Report</a>	WP5	CERN	18	24
<b>NED</b>	27	Commissioning of heat transfer facility	Prototype	WP2	CEA, WUT	16	delayed, 25
<b>NED</b>	28	Final report on Quench Protection	<a href="#">Report</a>	WP2	INFN-Milano	18	23
<b>NED</b>	29	Report on conventional insulation	Report	WP4	CCLRC-RAL	24	delayed, 30
<b>NED</b>	30	Report on innovative insulation	Report	WP4	CEA	18	delayed, 36

### 3. Use and dissemination of knowledge

The CARE dissemination board includes the seven activity deputy coordinators and is chaired by the CARE deputy coordinator. The dissemination of knowledge activity focused on the publication of scientific articles presenting work partially funded by the CARE activity, on establishing Web sites and on promoting the CARE results at accelerator conferences.

#### 3.1 Web Sites

The central CARE Web site <http://care.lal.in2p3.fr/>, with a new URL, has been regularly updated. It includes:

- Links to the seven activity (NA and JRA) Web sites
- CARE official documents (Consortium agreement, Annex I, etc...)
- The table of CARE deliverables
- The CARE management network and directory
- The calendar of CARE meetings
- A link to the Publication repository
- Advertisements for vacant CARE funded temporary positions.

All seven activity Web sites are active and regularly updated by the corresponding activity management. Most of these Web sites provide access to informative Work Package Web pages.

#### 3.2 Publications

Anticipating that the number of PhD thesis initiated by CARE will become larger in the remaining years of the project, a new category of publication, namely PhD thesis, has been added to the 5 already existing categories established by the CARE dissemination board according to the following table:

Publication category	Type of publication and Responsibility	Reviewing	Storage and numbering
CARE/Activ Document-year-number	Technical documents Responsibility of the authors	No review	Stored locally in NA/JRA web sites Numbering by NA/JRA coordinators
CARE-Pub-year-number	Journal publications CARE responsibility	Internal review	Stored in CARE web site Central numbering
CARE-Report-year-number	Yearly reports, and final deliverables to EC CARE responsibility	Submitted to EU commission	Stored in CARE web site Central numbering
CARE-Conf-year-number-Activ	Conference proceedings NA/JRA responsibility	Abstract approved by NA/JRA coordinators Internal review	Stored in CARE web site Central numbering
CARE-Note-year-number-Activ	CARE workshops and reviewed papers not aimed at publication CARE responsibility	Internal review	Stored in CARE web site Central numbering
CARE-Thesis-year-number-Activ	PhD thesis partly funded by CARE CARE responsibility	Internal review	Stored in CARE web site Central numbering

## Publication Web Repository

All CARE papers belonging to the last five categories are stored and are publicly available on Web-based publication repository <http://www-dapnia.cea.fr/Documentation/Care/index.php>. This Web repository is linked to the central CARE Web site from a new Web page <http://care.lal.in2p3.fr/Publications/> which includes straightforwardly the following requested acknowledgement to the EC support:

*We acknowledge the support of the European Community-Research Infrastructure Activity under the FP6 "Structuring the European Research Area" programme (CARE, contract number RII3-CT-2003-506395).*

The repository has also migrated to a new Web server to ensure better maintenance and it is regularly updated by members of the CEA documentation group.

The following table records the number of CARE scientific articles issued by the different activities (NA and JRA) in each category.

<b><u>2005 CARE Publications</u></b>					
	<b>Journal Publications</b>	<b>Conferences</b>	<b>Notes</b>	<b>Reports</b>	<b>Thesis</b>
<b>ELAN</b>		2	7	3	
<b>BENE</b>				4	
<b>HHH</b>	1	8	2	3	
<b>SRF</b>	13	29	6	3	
<b>PHIN</b>		1		5	1
<b>HIPPI</b>	1	11	7	4	
<b>NED</b>	5	2		4	
<b>ALL</b>	1	1		1	
<b>TOTAL</b>	<b>21</b>	<b>54</b>	<b>22</b>	<b>27</b>	<b>1</b>

## Publication lists for 2005:

The list of CARE papers can be directly uploaded from the following Web pages:

- CARE Journal Publications:  
<http://www-dapnia.cea.fr/Documentation/Care/care-pub-index-2005.php>
- CARE Reports:  
<http://www-dapnia.cea.fr/Documentation/Care/care-rapport-index-2005.php>
- CARE Conference Proceedings:  
<http://www-dapnia.cea.fr/Documentation/Care/care-conf-index-2005.php>
- CARE Notes:
  - ELAN: <http://www-dapnia.cea.fr/Documentation/Care/care-note-elan-index-2005.php>
  - BENE: <http://www-dapnia.cea.fr/Documentation/Care/care-note-bene-index-2005.php>
  - HHH: <http://www-dapnia.cea.fr/Documentation/Care/care-note-hhh-index-2005.php>
  - SRF: <http://www-dapnia.cea.fr/Documentation/Care/care-note-srf-index-2005.php>
  - PHIN: <http://www-dapnia.cea.fr/Documentation/Care/care-note-phin-index-2005.php>
  - HIPPI: <http://www-dapnia.cea.fr/Documentation/Care/care-note-hippi-index-2005.php>
  - NED: <http://www-dapnia.cea.fr/Documentation/Care/care-note-ned-index-2005.php>

### 3.3 Conference Presentations

The following table lists the presentations at major accelerator conferences and workshops, excluding the ones organized under CARE, of the scientific results obtained within the CARE collaboration. The presentation files are publicly available at the CARE Web page <http://care.lal.in2p3.fr/Publications/>.

	<b>Subject</b>	<b>Speaker/Lab</b>	<b>Event</b>	<b>Date</b>
Management	EU Supported Accelerator Activities	R. Aleksan / CEA	EPS Conference HEP2005 <a href="http://www.lip.pt/events/2005/hep2005/">http://www.lip.pt/events/2005/hep2005/</a>	21-27/07/05 Lisbon (P)
Management	The CARE Project	O. Napoly / CEA	International Conference on Accelerator Application <a href="http://accapp05.infn.it/">http://accapp05.infn.it/</a>	29/08-1/09/05 Venice (I)

## Annexes

### **Annex 1 – Summaries and main conclusions of the General Meeting**

The CARE general meeting, CARE05, took place at CERN, Geneva (Switzerland) on Nov. 23-25, 2005. The meeting Web site <http://hep-lab.web.cern.ch/HEP-lab/CARE05/JRANA.htm> provides the information concerning the participation (195 participants), the scientific program and the presentations. An overview of the program is given on the next page.

The general meeting included one day of plenary session devoted to 12 highlight talks invited by the seven CARE activities to report on the most significant developments in their field of research. It also included one day of parallel of sessions dedicated to the CARE activity workshops and internal meetings to prepare for their annual report.

An important part of the program was the plenary session on November 25 dedicated to the summary talks of the seven CARE activity coordinators. They all reported on the continued commitment of the institutes and their scientists towards the CARE programme and the objectives of the CARE activities. They also reported on the impressive amount of scientific and technical work already accomplished. Significant results have already been obtained, outlined elsewhere in this document, and no significant delays or difficulties appeared in their respective programme. In general, the progress of the second year of the CARE project has been quite satisfactory.

Like in 2004, the meeting was attended by CARE's Scientific Officer, Mr. Daniel Pasini who made a presentation of the goals, the instruments and the preparation of the FP7 programme. In his concluding remarks, the CARE coordinator discussed the possibilities for the continuation of the CARE project in FP7.



A. ACTIVITY REPORT

	Wednesday, November 23		Thursday, November 24		Friday, November 25
08:00	Registration Library 7th floor building 30				
09:00	<b>PLENARY (Auditorium)</b>	09:00	<b>PLENARY</b>	09:00	<b>PLENARY (Auditorium)</b>
AT Aud 30/7-018	<b>Introduction session</b> Chair: G. Guignard	AT Aud 30/7-018	<b>Highlight talks</b> Chair:	AT Aud 30/7-018	<b>JRA Activity Reports</b> Chair:
09:00	Welcome - From the Lab. Director hosting the general CARE meeting, R.Aymar CERN/DG (10mn)	09:00	MERIT, its scientific goals and importance J. Lettry, CERN. (20mn)	09:00	Report on SRF Activities D.Proch/T.Garvey DESY/IN2P3 (30+5mn)
09:10	CARE General Status & Plans - by CARE coordinator, R.Aleksan CEA/IN2P3 (20 mn)	09:20	Advances of the Low Level RF control (LLRF) for VUVFEL. S.Simrock, DESY. (20mn)	09:35	Report on PHIN Activities A. Ghigo INFN (20+5mn)
09:30	CARE Dissemination Activities by Dissemination Board Chair. O. Napoly, CEA (20mn)	09:40	The Superconducting photoinjector at Rossendorf. J.Teichert, FZ Rossendorf. (20mn)	10:00	Report on HIPPI Activities M. Vretenar CERN (20+5mn)
09:50	Strategy Group activity. T.Akesson ( 10mn )	10:00	Development of the CH-DTL accelerating structure.U. Ratzinger, IAP-Frankfurt. (20mn)	10:25	Report on NED Activities A. Devred CERN (20+5mn)
		10:20	Insulation materials development for the Next European Dipole project.S.Canfer,RAL (15mn)		
		10:35	Recent activities/results on pulsed SC magnet for the CERN and GSI accelerator complex. L. Bottura, CERN (10mn)		
10:00	<i>Coffee Break</i>	10:45	<i>Coffee Break</i>	10:50	<i>Coffee Break</i>
10:30	<b>PLENARY</b>	11:15	<b>PARALLEL</b>	11:10	<b>PLENARY (Auditorium)</b>
AT Aud 30/7-018	<b>Highlight talks</b> Chair:		Networking/Joint Research Activities		<b>JRA Activity Reports</b>
10:30	Recent results on beam optics for the LHC upgrade: J-P.Koutchouk, CERN (15mn)	AB Aud 6/2-024	ELAN	AT Aud 30/7-018	Chair: R. Aleksan
10:45	Progress in the HIPPI code benchmarking A. Franchi, GSI. (20mn)	IT Aud 31/ 3-004	ECFA / BENE	11:10	Report on ELAN Activities F. Richard LAL (20+5mn)
11:05	Superconducting RF Cavities for Electron Linear Accelerators. B.Visentin, CEA. (30mn)	112/R-034	HHH (ABI)	11:35	Report on BENE Activities V. Palladino INFN (20+5mn)
11:35	The PHIN Photoinjector for CTF3. R.Losito,CERN. (20mn)	AT Aud 30/7-018	SRF + HIPPI +PHIN	12:00	Report on HHH Activities F. Ruggiero CERN (20+5mn)
11:55	Design of a tuning system for high gradient superconducting accelerating cavities. P. Sekalski, TU Lodz. (20mn)	13/2-005	NED	12:25	FP7 presentation D. Pasini, Europ.Comm.(15mn)
12:15	Magnetization measurements as a tool for investigating the potential electrical transport properties of Nb3Sn superconducting wires.M.Greco, INFN-Ge. (20mn)			12:40	Concluding remarks R. Aleksan CEA/IN2P3 (15mn)
12:35	<i>Lunch</i>	12:45	<i>Lunch</i>	12:55	<i>Lunch</i>
14:00	<b>PARALLEL</b>	14:00	<b>PARALLEL</b>	14:30	
	Networking Activities		ATLAS Visit 2:00pm to 4:00pm Networking/Joint Research Activities	60/6-002	Governing Board
AB Aud 6/2-024	ELAN	AB Aud 6/2-024	ELAN		
IT Aud 31/ 3-004	ECFA / BENE	IT Aud 31/ 3-004	ECFA / BENE		
AT Aud 30/7-018	HHH (AMT)	AT Aud 30/7-018	HHH (AMT)		
112/R-034	SRF	112/R-034	HHH (APD)		
6/2-004	PHIN	30/7-012	HIPPI		
		13/2-005	NED		
		AT Aud 30/7-018	SRF + HIPPI +PHIN		
16:00	<i>Coffee Break</i>	16:00	<i>Coffee Break</i>	16:30	<i>Coffee Break</i>
16:30	<b>PARALLEL</b>	16:30	<b>PARALLEL</b>	16:45	
	Networking Activities		Networking/Joint Research Activities	60/6-002	Steering Committee / Dissemination Board
AB Aud 6/2-024	ELAN	AB Aud 6/2-024	ELAN Steering Committee		
IT Aud 31/ 3-004	ECFA / BENE	IT Aud 31/ 3-004	ECFA / BENE		
AT Aud 30/7-018	HHH (AMT)	AT Aud 30/7-018	HHH (AMT)		
112/R-034	SRF	112/R-034	HHH (APD)		
6/2-004	PHIN	6/2-004	PHIN		
30/7-012	HIPPI (+HHH/APD)	30/7-012	HIPPI		
		13/2-005	NED		
17:30	Visit of the labo for the R&D				
		18:30	<i>Adjourn</i>	18:00	<i>Adjourn</i>
18:15	<b>COCKTAIL Restaurant 2</b>	19:30	<b>CARE Dinner Restaurant 2</b>		

## B. Management Report (financial information)

### 1. Justification of the resources deployed

Contract N°	RII3-CT-2003-506395	Project acronym	CARE
Participant N°	1	Participant short name	CEA
		<b>Management</b>	
		Total effort in person-months <sup>(1)</sup>	22.9
<b>Cost category</b>	<b>Actual direct eligible costs (€)</b>	<b>Justification of costs</b> description of expenditure and link to the specific work carried out (e.g. tasks, work packages, ...)	
Personnel cost <sup>(2)</sup>	162 000,95	Permanent personnel for CARE management: CARE coordinator and deputy coordinator, financial assistant, secretary, accounting office.	
Durable equipment			
Consumable and prototyping	202,00	Meeting room fees for the VIT@MIB meeting (November 2004) at CNRS-Paris.	
Travel	3 762,58	Participation in the : CARE Steering committees 1st CERN (2 persons), 2nd Paris (2 persons); CARE Annual meeting (2 persons); Meeting in Frankfurt (1 person); AccApp05 Conference in Venice for a CARE invited talk (1 person).	
Audit certificate	0,00	audit certificate	
		<b>N1-ELAN - Electron Linear Accelerator Network</b>	
		Total effort in person-months <sup>(1)</sup>	
<b>Cost category</b>	<b>Actual direct eligible costs (€)</b>	<b>Justification of costs</b> description of expenditure and link to the specific work carried out (e.g. tasks, work packages, ...)	
Personnel cost <sup>(2)</sup>			
Durable equipment			
Consumable and prototyping			
Travel	5 501,96	Participation in the ELAN supported meetings: ELAN-ILC Regional meeting at London (1 person); SRF'05 Workshop at Cornell (1 person); Collimation meeting at Daresbury (1 person); TTC meeting at Hamburg (1 person).	

		<b>N2-BENE - Beam for European Neutrino Experiments</b>	
		<b>Total effort in person-months <sup>(1)</sup></b>	
<b>Cost category</b>	<b>Actual direct eligible costs (€)</b>	<b>Justification of costs</b> <i>description of expenditure and link to the specific work carried out (e.g. tasks, work packages, ...)</i>	
<b>Personnel cost <sup>(2)</sup></b>			
<b>Durable equipment</b>			
<b>Consumable and prototyping</b>			
<b>Travel</b>	7 793,62	Participation in the BENE supported meetings: First Beta-Beam meeting at Oxford (5 persons); BENE week at CERN (3 persons); NuFact'05 workshop at Frascati (1 person); AccApp05 conference at Venice (1 person).	
		<b>N3-HHH - High Energy High Intensity Hadron Beams</b>	
		<b>Total effort in person-months <sup>(1)</sup></b>	
<b>Cost category</b>	<b>Actual direct eligible costs (€)</b>	<b>Justification of costs</b> <i>description of expenditure and link to the specific work carried out (e.g. tasks, work packages, ...)</i>	
<b>Personnel cost <sup>(2)</sup></b>			
<b>Durable equipment</b>			
<b>Consumable and prototyping</b>			
<b>Travel</b>	5 476,61	Participation in the HHH supported meetings: HHH/AMT workshop on insulation (2 persons); DOE review of the LARP program at Fermilab (1 person) ; invited talk at SPIE congress in Warsaw (1 person).	
		<b>R1-SRF - Superconducting Radio Frequency</b>	
		<b>Total effort in person-months <sup>(1)</sup></b>	143.2
<b>Cost category</b>	<b>Actual direct eligible costs (€)</b>	<b>Justification of costs</b> <i>description of expenditure and link to the specific work carried out (e.g. tasks, work packages, ...)</i>	
<b>Personnel cost <sup>(2)</sup></b>	688 646,47	Permanent and additional personnel for WP5 (Surface Preparation), Task 5.1 (EP for single cell): EP studies on Nb samples, fabrication and security certification of EP set-up, reception of 3 single cell cavities. Permanent and additional personnel for WP8 (Tuners): Task 8.3 (CEA tuner) - reception of 2 complete tuners with piezo-electric crystals, first warm ad cold tests. WP10 (Tests in CRYHOLAB) project management, high gradient cavity test and first test of CEA piezo-tuner system. Permanent and additional personnel for WP11 (Beam Diagnostics), Task 11.1: appropriation and reception of the first beam position monitor cavity including its feedtroughs and electronics, mechanical design for a second BPM cavity prototype; beam studies of the BPM cavity at DESY-TTF; tests of 50 HOM-BPM electronics boards at SLAC (Stanford);	
<b>Durable equipment</b>	6 482,35	WP5: purchasing of EP set-up cryothermostat. WP10: ionic pump. WP8: purchasing of one RF-laboratory PC. WP11: purchasing of one RF-laboratory PC.	
<b>Consumable and prototyping</b>	81 751,81	WP5: purchasing of electropolishing set-up cryothermostat , 3 single cell cavities, chemical products and tanks; WP8 : purchasing of 2 tuner mechanics, piezo-amplifiers and RF components, ; WP10 : oil for CryHoLab modulator; WP11: purchasing of one BPM cavity, electronics boards, connectors, antennas, hybrid couplers and other RF components.	
<b>Travel</b>	19 732,23	Participation in the CARE/SRF meetings: CARE'05 meeting, CERN (2 persons); SRF'05 meeting at Legnaro (4 persons); work stay at SLAC, Stanford (1 person, 1 month); BPM beam tests at DESY, Hamburg (4 persons, 1 week);	

		<b>R3- HIPPI - High Intensity Pulsed Proton Injector</b>	
		<b>Total effort in person-months <sup>(1)</sup></b>	45.9
<b>Cost category</b>	<b>Actual direct eligible costs (€)</b>	<b>Justification of costs</b> <i>description of expenditure and link to the specific work carried out (e.g. tasks, work packages, ...)</i>	
<b>Personnel cost <sup>(2)</sup></b>	271 038,44	Permanent personnel for WP2 (coupler design), WP3 (design of superconducting cavity and coupler, studies of modifications of HV generator, preparation of orders for the 1MW klystron, the circulator, the HV power supply and for the Niobium for cavity fabrication). Permanent and additional personnel for WP5 (...) for beam dynamics studies (development of code for the study of coupling between the plasma and the EM wave in an ECR source)	
<b>Durable equipment</b>	3 972,16	WP3:RF loads, laboratory equipment for tuning system studies	
<b>Consumable and prototyping</b>	55 072,90	WP3: Niobium for cavity fabrication, acid for cavity preparation, mechanical modifications of High Pressure Rinsing set-up, electronic components for tuning system studies, RF material for the power test stand	
<b>Travel</b>	7 960,50	Participation to CARE/HIPPI meetings: CARE'05 at CERN (2 persons); HIPPI'05 at Oxford (5 persons); WP2 meetings at CERN (1 person) ; WP3 meeting at Milan(4 persons); WP5 meeting at Oxford (1 person); technical meetings; two-way Moscow home flight for temporary staff (I. Roudskoy, ITEP)	
		<b>R4- NED - Next European Dipole</b>	
		<b>Total effort in person-months <sup>(1)</sup></b>	27.1
<b>Cost category</b>	<b>Actual direct eligible costs (€)</b>	<b>Justification of costs</b> <i>description of expenditure and link to the specific work carried out (e.g. tasks, work packages, ...)</i>	
<b>Personnel cost <sup>(2)</sup></b>	120 829,52	Permanent personnel for Activity management and coordination (WP1); Permanent personnel for WP2 (Thermal Studies and Quench Protection): follow up of cryostat and heat exchanger module fabrication in Wroclaw, fabrication and test of parts for cryostat, participation to reception tests of cryostat in Wroclaw; Permanent personnel for WP3 (Conductor development): critical current measurements.	
<b>Durable equipment</b>	139,78	WP2 (Thermal Studies and Quench Protection): purchasing of heat exchanger module for double-bath cryostat, temperature instrumentation.	
<b>Consumable and prototyping</b>	4 692,64	WP2 (Thermal Studies and Quench Protection): purchasing of components for leak tight feed throughs; WP3 (Conductor Development): purchasing of components and sample holders for critical current measurements.	
<b>Travel</b>	12 936,77	Participation to CARE/NED meetings: January NED SC meeting at CERN (2 people); April NED SC meeting at CERN (2 persons); June NED SC meeting at Wroclaw (3 persons); meeting on beam loss at CERN (WP2) (1 person); cryostat reception tests at Wroclaw (2 persons); WGCC meeting at INFN/Milan (2 persons); December 04 WGMDO meeting at CIEMAT (3 persons); April WGMDO meeting at CERN (1 person); June WGMDO meeting at CCLRC (3 person); EUCAS conference (1 person); CARE'05 at CERN (3 persons)	
<b>Total direct eligible costs</b>	<b>1 457 993,29</b>		
<b>Total indirect costs</b>	<b>919 475,89</b>		
<b>Total costs <sup>(3)</sup></b>	<b>2 377 469,18</b>	Global estimate of the total costs for AC contractors (not only the eligible costs)	
<b>Justify any deviations with respect to the planned budget</b>			
an adjustment of <b>-1 962,98</b> euros for the 2004 costs is to be subtracted to the total 2005 costs: the adjusted 2005 is thus <b>2 375 506,20</b> euros			
received 6/2/2006			

(1) AC contractors must include both the total estimated human effort (including permanent staff) and, in brackets, additional staff only.

(2) For TA activities excluding the effort charged under the user fees if the UF cost model is used.

(3) Totals should correspond to the respective figures on FORM C - Financial Statement

B. MANAGEMENT REPORT (FINANCIAL INFORMATION)

Contract N°	RII3-CT-2003-506395	Project acronym	CARE
Participant N°	2	Participant short name	UCLN
		<b>Management</b>	
		Total effort in person-months <sup>(1)</sup>	
Cost category	Actual direct eligible costs (€)	Justification of costs <i>description of expenditure and link to the specific work carried out (e.g. tasks, work packages, ...)</i>	
Audit certificate	300,00	audit certificate	
		<b>N2-BENE - Beam for European Neutrino Experiments</b>	
		Total effort in person-months <sup>(1)</sup>	1
Cost category	Actual direct eligible costs (€)	Justification of costs <i>description of expenditure and link to the specific work carried out (e.g. tasks, work packages, ...)</i>	
Personnel cost <sup>(2)</sup>			
Durable equipment			
Consumable and prototyping	31,22	Express mail	
Travel	1 739,27	1 person EURISOL 17-18/1/2005 Didcot(UK ), 1 person Care-Bene 7/4/2005 Orsay(F), 1 person Care-Bene 14/4/2005 CERN, 1 person 21-24/10/2005 meeting MICE, Ruth. Lab(UK)	
Total direct eligible costs	2 070,49		
Total indirect costs	354,10		
Total costs <sup>(3)</sup>	2 424,59	Global estimate of the total costs for AC contractors (not only the eligible costs)	6000
<b>Justify any deviations with respect to the planned budget</b>			

<sup>(1)</sup> AC contractors must include both the total estimated human effort (including permanent staff) and, in brackets, additional staff only.

<sup>(2)</sup> For TA activities excluding the effort charged under the user fees if the UF cost model is used.

<sup>(3)</sup> Totals should correspond to the respective figures on FORM C - Financial Statement

<b>Contract N°</b>	<b>RII3-CT-2003-506395</b>	<b>Project acronym</b>	<b>CARE</b>
<b>Participant N°</b>	<b>3</b>	<b>Participant short name</b>	<b>CNRS</b>
		<b><i>N1-ELAN - Electron Linear Accelerator Network</i></b>	
		<b>Total effort in person-months <sup>(1)</sup></b>	
<b>Cost category</b>	<b>Actual direct eligible costs (€)</b>	<b>Justification of costs</b> <i>description of expenditure and link to the specific work carried out (e.g. tasks, work packages, ...)</i>	
<b>Personnel cost <sup>(2)</sup></b>	<b>Personnel cost <sup>(2)</sup></b>		
<b>Durable equipment</b>			
<b>Consumable and prototyping</b>			
<b>Travel</b>	32119.07 (UPS), 6275.26 (LAL), 616.95 (LPGP)	Linear Collider Workshop, San Francisco (2 people), TESLA Collaboration meeting, Hamburg (1 person), Workshop on positron sources for ILC, Daresbury (3 people), CARE steering committee meeting, Geneva (1 person), Registration fees High Energy Electron Acceleration using Plasmas workshop, Paris (19 people), European ILC-BDIR meeting, London (4 people), American Linear Collider Physics Workshop, Snowmass (4 people). European Industrial Forum, Hamburg (2 people), European GDE meeting, Oxford (3 people), Annual CARE meeting, Geneva ( 1 person), ICFA seminar (1 person).	
		<b><i>N2-BENE - Beam for European Neutrino Experiments</i></b>	
		<b>Total effort in person-months <sup>(1)</sup></b>	
<b>Cost category</b>	<b>Actual direct eligible costs (€)</b>	<b>Justification of costs</b> <i>description of expenditure and link to the specific work carried out (e.g. tasks, work packages, ...)</i>	
<b>Personnel cost <sup>(2)</sup></b>			
<b>Durable equipment</b>			
<b>Consumable and prototyping</b>			
<b>Travel</b>	4599.96 (LAL), 1813.40 (UPS)	Neutrino Factory Workshop, Frascati (1 person), International Scoping Study, Geneva via Lyon (1 person), Neutrino factory meeting at CERN (1 person).	



		Total effort in person-months <sup>(1)</sup>	140 (LAL), 24 (IPNO)
Cost category	Actual direct eligible costs (€)	Justification of costs <i>description of expenditure and link to the specific work carried out (e.g. tasks, work packages, ...)</i>	
Personnel cost <sup>(2)</sup>	454493.04 (LAL), 83678.71 (IPNO)	Permanent personnel for WP7 (couplers), Task 7.1 (proto-types) - Thermal calculations, purchase of code for calculations, surface studies, engineering drawings, critical review meetings, calls for tenders. Additional (temporary) personnel for drawings of new TTF-III proto-types. Ordering of proto-types. Task 7.2 (TiN coating bench) - preparation of technical specification. Visits to potential suppliers. Task 7.3 (Conditioning studies) - personnel for reception, control, clean room preparation and mounting of couplers for RF conditioning. Improvements in automated conditioning procedure, studies of bake-out and vacuum handling procedures, documentation of these procedures. Analysis of conditioning data. Operation of high power test equipment. Dissemination of information on coupler WEB page and preparation of communications to CARE meetings. Presentation of results in meetings and conferences, writing papers for these conferences. Project management of WP7. Permanent personnel (IPNO) for WP8 (tuners). Tests of piezo-electric transducers, Radiation hardness tests.	
Durable equipment	15315.82 (LAL), 38.08 (IPNO)	(WP7) - Ultra-pure water production consumables, UP water storage, copies of drawings, clean room consumables, nitrogen gas, coupler prototypes, vacuum seals, vacuum parts, ANSYS software licence, calls for tender announcements, detergents, interlock parts, power supply, filters, storage cabinets, transformers, circuit breaker. (WP8) - Liquid helium, electronic components, piezo-electric components.	
Consumable and prototyping	39609.05 (LAL)	(WP7) - Lifting table, tender announcement, clean room consumables, gloves, chemical resin, nitrogen and helium bottles. (WP8) - Irradiation chamber, software licence, temperature sensors.	
Travel	8113.13 (UPS)	TESLA Collaboration meeting, Hamburg (3 people), Technical discussions, DESY-Hamburg (1 person), CARE Steering committee meeting, Geneva (1 person), Visit to company, ACCEL-Cologne (3 people), Attendace at SPIE conference, Warsaw (1 person), Technical visit, Paris (1 person).	
		<b>R2- PHIN - Photo Injector</b>	
		Total effort in person-months <sup>(1)</sup>	50 (LAL), 63 (LOA)
Cost category	Actual direct eligible costs (€)	Justification of costs <i>description of expenditure and link to the specific work carried out (e.g. tasks, work packages, ...)</i>	
Personnel cost <sup>(2)</sup>	246329.56 (LOA) 184101.35 (LAL)	Permanent personnel (Orsay) for WP4. Task 4.2 - Design of RF gun: RF simulations, engineering drawings, conception of vacuum chamber, design of magnetic focusing elements and beam dynamics calculations. Dissemination of information. Project management. Collaboration meetings with CERN on CTF3. Also, design of photo-cathode preparation chamber. Study of offers of laser, reception and test of laser. Test of proto-type cavity at low power. Infrastructure preparation of NEPAL laboratory. Purchase of solenoid focusing magnets. Purchase of optical table. Vacuum equipment for CTF. Administrative work for approval for beam tests in NEPAL laboratory. Permanent personnel (LOA) for task 4.3 - design of low and high energy spectrometers. Experiments on laser-plasma acceleration. Contractual personnel for these experiments.	
Durable equipment	5498.41 (LAL)	Master oscillator, proto-type cavity, optical components, valves, ion pumps, stainless steel	
Consumable and prototyping	2912.16 (LAL), 87377.70 (LOA)	(LAL-Orsay) - High purity copper, thermometers, vacuum components. (LOA) electronic material, optical material, laser components.	
Travel	9751.69 (LOA), 674.31 (UPS)	Technical meetings at CERN (UPS, 3 people). (LOA) - Geant 4 symposium, Bordeaux (3 people), CLEO conference, Munich (1 person), SFP meeting, Roscoff (1 person), CARE meeting, Geneva (1 person), Plasma conferences, Italy (2 people), EPS meeting, Taragone (1 person) ESTRO conference, Lisbon (1 person).	

		<b>R3- HIPPI - High Intensity Pulsed Proton Injector</b>	
		Total effort in person-months <sup>(1)</sup>	19,7 (LPSC), 8,3 (IPNO)
Cost category	Actual direct eligible costs (€)	Justification of costs <i>description of expenditure and link to the specific work carried out (e.g. tasks, work packages, ...)</i>	
Personnel cost <sup>(2)</sup>	79391.90 (LPSC) 36047.14 (IPNO)	Radio-frequency and thermal design work on cavities. Design of power coupler for multi-gap spoke cavity.	
Durable equipment	66.33 (LPSC)	computer material	
Consumable and prototyping			
Travel	2417.27 (LPSC)	WP2 meetings, Geneva (5 people) , Annual HIPPI meeting, Oxford ( 1 person), Low-level RF workshop and LINAC4 meetings, Geneva (6 people).	
Total direct eligible costs	1 301 240,29		
Total indirect costs	260 248,05		
Total costs <sup>(3)</sup>	1 561 488,34	Global estimate of the total costs for AC contractors (not only the eligible costs)	
<p><b>Justify any deviations with respect to the planned budget</b></p> <p><b>An adjustment of +32 784,95 euros (CNRS) and +8563,13 euros (University Paris-Sud) for the 2004 costs is to be added to the total 2005 costs: the total adjusted costs for 2005 is thus 1 602 836,42 euros.</b></p> <p>Delay in construction of titanium-nitride coating bench while awaiting validation of coating procedures used by industrial suppliers (SRF WP7)</p> <p>Delay in construction of photo-injector for CERN due to evolving specifications. Delay in construction of accelerator at Orsay due to new safety regulations (PHIN)</p>			

<sup>(1)</sup> AC contractors must include both the total estimated human effort (including permanent staff) and, in brackets, additional staff only.

<sup>(2)</sup> For TA activities excluding the effort charged under the user fees if the UF cost model is used.

<sup>(3)</sup> Totals should correspond to the respective figures on FORM C - Financial Statement

B. MANAGEMENT REPORT (FINANCIAL INFORMATION)

Contract N°	RII3-CT-2003-506395	Project acronym	CARE
Participant N°	4	Participant short name	GSI
		<b>N2-BENE - Beam for European Neutrino Experiments</b>	
		Total effort in person-months <sup>(1)</sup>	2,5
<b>Cost category</b>	<b>Actual direct eligible costs (€)</b>	<b>Justification of costs</b> <i>description of expenditure and link to the specific work carried out (e.g. tasks, work packages, ...)</i>	
Personnel cost <sup>(2)</sup>	0,00		
Durable equipment	0,00		
Consumable and prototyping	0,00		
Travel	384,72	1 person, Abington, UK, work meeting, WP5	
		<b>N3-HHH - High Energy High Intensity Hadron Beams</b>	
		Total effort in person-months <sup>(1)</sup>	2,5
<b>Cost category</b>	<b>Actual direct eligible costs (€)</b>	<b>Justification of costs</b> <i>description of expenditure and link to the specific work carried out (e.g. tasks, work packages, ...)</i>	
Personnel cost <sup>(2)</sup>	0,00		
Durable equipment	0,00		
Consumable and prototyping	0,00		
Travel	4 476,51	1 person, CERN, workshop 2 persons, CERN, workshop 3 persons, Hirschberg, workshop,	

<b>R3- HIPPI - High Intensity Pulsed Proton Injector</b>		
		<b>Total effort in person-months <sup>(1)</sup></b>
		<b>37,2</b>
<b>Cost category</b>	<b>Actual direct eligible costs (€)</b>	<b>Justification of costs</b> <i>description of expenditure and link to the specific work carried out (e.g. tasks, work packages, ...)</i>
<b>Personnel cost <sup>(2)</sup></b>	193 353,83	WP5 exclusively: non-distr. transv. profile meas.: 2,8 PM on-line transmission control: 0,3 PM coordination of beam diagn. works: 1,8 PM preparation of UNILAC experiment: 17,0 PM simulation of UNILAC experiment: 3,0 PM high current modelling, code improvement: 9,3 PM WP management: 3,0 PM
<b>Durable equipment (depreciation)</b>	4 841,00	camera and electronics for beam diagnosis
<b>Consumable and prototyping</b>	4 592,92	Measurement unit for residual gas fluorescence detection
<b>Travel</b>	10 499,60	4 persons, Abington, UK, WP5 Meeting 1 person, Lyon, DIPAC Conference (WP5) 4 persons, Abington, UK, HIPPI05 Meeting 2 persons, CERN, CARE05
<b>Total direct eligible costs</b>	<b>218 148,58</b>	
<b>Total indirect costs</b>	<b>34 433,75</b>	
<b>Total costs <sup>(3)</sup></b>	<b>252 582,33</b>	<b>Global estimate of the total costs for AC contractors (not only the eligible costs)</b>
<b>Justify any deviations with respect to the planned budget</b>		
The budget foreseen for prototyping was not used this year due to the unexpected leave of the staff in charge in August. The vacancy will be filled in December and the budget will be spend in the first few months of 2006 instead.		

received 6/2/2006

<sup>(1)</sup> AC contractors must include both the total estimated human effort (including permanent staff) and, in brackets, additional staff only.<sup>(2)</sup> For TA activities excluding the effort charged under the user fees if the UF cost model is used.<sup>(3)</sup> Totals should correspond to the respective figures on FORM C - Financial Statement

<b>Contract N°</b>	RII3-CT-2003-506395	<b>Project acronym</b>	CARE
<b>Participant N°</b>	5	<b>Participant short name</b>	IAP-FU
<b>Management</b>			
		<b>Total effort in person-months <sup>(1)</sup></b>	
<b>Cost category</b>	<b>Actual direct eligible costs (€)</b>	<b>Justification of costs</b> description of expenditure and link to the specific work carried out (e.g. tasks, work packages, ...)	
<b>Audit certificate</b>	566,94	audit certificate 2004	
<b>R3- HIPPI - High Intensity Pulsed Proton Injector</b>			
		<b>Total effort in person-months <sup>(1)</sup></b>	51 (39 = 26 university + 13 HIPPI EU)
<b>Cost category</b>	<b>Actual direct eligible costs (€)</b>	<b>Justification of costs</b> description of expenditure and link to the specific work carried out (e.g. tasks, work packages, ...)	
<b>Personnel cost <sup>(2)</sup></b>	65 723,82	4 additional staff members (scientists/researchers), as follows: - 1 add. staff member hired from 2004 until 02.2005. Activities within WP2 and WP5: LORASR code development: programming + simulation studies. - 1 add. staff member hired from 2004 until 05.2005. Activities within WP2 and WP5: LORASR code development: programming + simulation studies. - 1 add. staff member under contract since 10.2004. Activities within WP3 and WP5 : LORASR code benchmarking : simulation studies; SC CH cavity tuner design : design work. - 1 add. staff member under contract since 11.2005. Activities within WP2 and WP5: Beam dynamics design: simulation studies; CH model and prototype cavity design: design work.	
<b>Durable equipment</b>			
<b>Consumable and prototyping</b>	0,00	All costs accrued in 2005 were financed by own resources.	
<b>Travel</b>	3 654,57	Participation to the HIPPI Work Package meetings (14.4.-15.4. WP5, Abingdon, UK, 1 person; 2.6.-3.6., CERN, Switzerland, 1 person) and the HIPPI Annual Meeting (28.9.-30.9., Abingdon, UK, 3 persons). Participation to the General CARE Annual Meeting (23.11.-25.11., CERN, Switzerland, 1 person)	
<b>Total direct eligible costs</b>	<b>69 945,33</b>		
<b>Total indirect costs</b>	<b>13 875,68</b>		
<b>Total costs <sup>(3)</sup></b>	<b>83 821,01</b>	<b>Global estimate of the total costs for AC contractors (not only the eligible costs)</b>	300000
<b>Justify any deviations with respect to the planned budget</b>			
<p>Personnel cost: Scheduled budget was spent.</p> <p>Consumable and prototyping: All costs (WP2: model cavity; WP3: tuner components) were financed from own resources. It is planned to finance the "main items" (WP2: prototype cavity; WP3: tuner for SC-CH cavity) from the CARE-HIPPI support. These components are still in the design phase. This is why the requested EU funding will be mainly used in 2006.</p>			

<sup>(1)</sup> AC contractors must include both the total estimated human effort (including permanent staff) and, in brackets, additional staff only.

<sup>(2)</sup> For TA activities excluding the effort charged under the user fees if the UF cost model is used.

<sup>(3)</sup> Totals should correspond to the respective figures on FORM C - Financial Statement

<b>Contract N°</b>	<b>RII3-CT-2003-506395</b>	<b>Project acronym</b>	<b>CARE</b>
<b>Participant N°</b>	<b>6</b>	<b>Participant short name</b>	<b>DESY</b>
		<b><i>N1-ELAN - Electron Linear Accelerator Network</i></b>	
		<b>Total effort in person-months <sup>(1)</sup></b>	<b>2,2 (2,2)</b>
<b>Cost category</b>	<b>Actual direct eligible costs (€)</b>	<b>Justification of costs</b> <i>description of expenditure and link to the specific work carried out (e.g. tasks, work packages, ...)</i>	
<b>Personnel cost <sup>(2)</sup></b>			
<b>Durable equipment</b>			
<b>Consumable and prototyping</b>			
<b>Travel</b>	50 019,40	12th International Workshop on RF Superconductivity, Cornell, (12 physicist): exchange of the latest advances in technology and application of RF superconductivity; ILC European Regional Meeting in London/Oxford (6 physicist); 2nd ILC workshop at Snowmass studying and planning the linear collider program (3 physicist); JRA1-SRF Annual Meeting (4 physicist); DMCS Conference Slesin, Poland (2 physicist); microelectronics and compute science; Low Level RF workshop 2005, CERN (2 Physicist); Presentation Krakow university (1 physicist); Presentation Peking university (1 physicist)	
		<b><i>N3-HHH - High Energy High Intensity Hadron Beams</i></b>	
		<b>Total effort in person-months <sup>(1)</sup></b>	<b>0,8 (0,8)</b>
<b>Cost category</b>	<b>Actual direct eligible costs (€)</b>	<b>Justification of costs</b> <i>description of expenditure and link to the specific work carried out (e.g. tasks, work packages, ...)</i>	
<b>Personnel cost <sup>(2)</sup></b>			
<b>Durable equipment</b>			
<b>Consumable and prototyping</b>			
<b>Travel</b>	2 251,02	ECOMAG 2005, Frascati: HHH-AMT workshop on Superconducting Pulsed Magnets, (1 physicist); LHC Lumi 05, Arcidosso: review of overall scenario and needs for LHC upgrade, (2 physicist); 3rd CARE-HHH-ABI-Meeting, Hirschberg: Remote diagnostics and maintenance of beam instrumentation devices, (6 physicist)	



		<b>R1-SRF - Superconducting Radio Frequency</b>	
		<b>Total effort in person-months <sup>(1)</sup></b>	212 (36)
<b>Cost category</b>	<b>Actual direct eligible costs (€)</b>	<b>Justification of costs</b> <i>description of expenditure and link to the specific work carried out (e.g. tasks, work packages, ...)</i>	
<b>Personnel cost <sup>(2)</sup></b>	184 376,74	WP 1 Management&Communication: Administrative tasks (1 physicist 12 person-months); Task 3.2 Seamless cavities: design & commission of hydroforming machine (2 scientists, total 6 person-months); Task 5.2 Electropolishing of multicells (1 technician 4 person-months); Task 5.4 Dry ice cleaning: Installation and test of cleaning system (1 technician 4 person-months); Task 6.1 Design of squid scanning system: test of scanning system (1 scientist 4 person-months); Task 6.3 DC field emission scanning: Automation of apparatus and measurements (1 physicist 3 person-months); Task 9.1 Low level rf control: test of stable reference line (1 engineer 3 person-months);	
<b>Durable equipment</b>			
<b>Consumable and prototyping</b>	145 233,46	Task 2.3 Electron beam welding: Design and construction of a manipulator unit for e-beam welding; Task 3.2 Seamless cavity production: The tube necking machine was successfully constructed, Niobium tube material has been ordered; Task 5.2: Electropolishing: parameters for continuous runs are fixed and quality control is established; Task 5.4 Dry ice cleaning: Installation material for high purity dry ice production unit; Task 6.1 Squid scanning system: System is finished, second rate of subcontract for industrial development of squid scanning apparatus; first testing of functionality has been done; Task 6.3 DC field emission studies: Measurements have been started and first results have been presented; Task 9.1 Operability and technical performance: Hardware of filter for transient detection, circuitry for remote control and automatic system calibration is completed;	
<b>Travel</b>	32 410,65	Work package meetings with partners in Warsaw (3 persons), Paris (2 persons), Wuppertal (1 person), Legnaro 3 person); WILGA Conference (6 physicists); Presentations in Krakow (1 person) and Uppsala (1 person); Steering committee Geneva (2 persons) and Paris (2 persons); e-p meeting at University of Brussels (2 persons); JAR1 Annual Meeting (9 persons);	

<b>Total direct eligible costs</b>	<b>414 291,27</b>		
<b>Total indirect costs</b>	<b>71 798,25</b>		
<b>Total costs <sup>(3)</sup></b>	<b>486 089,52</b>	<b>Global estimate of the total costs for AC contractors (not only the eligible costs)</b>	<b>1 366 090</b>

**Justify any deviations with respect to the planned budget**

Spending for JRA1 in 2005 is about 85% of received support (adjustments to the previous period have been included in the individual activities and represent a total amount of -22 701,27 euros). The slight under spending is due to 1) delay in design and installation of mechanical rotation and transversal axis of the UHV beam welding equipment in WP2.3, and 2) delay in hiring a technician for the electronic control system for dry ice cleaning in WP5.4.

Spending in ELAN is 100% of received support.

Spending in HHH is about 35%. This considerable under spending is due to very late travel in December and subsequent accounting to the next year.

<sup>(1)</sup> AC contractors must include both the total estimated human effort (including permanent staff) and, in brackets, additional staff only.

<sup>(2)</sup> For TA activities excluding the effort charged under the user fees if the UF cost model is used.

<sup>(3)</sup> Totals should correspond to the respective figures on FORM C - Financial Statement

Contract N°	RII3-CT-2003-506395	Project acronym	CARE
Participant N°	7	Participant short name	FZJ
		<b>N1-ELAN - Electron Linear Accelerator Network</b>	
		Total effort in person-months <sup>(1)</sup>	1
Cost category	Actual direct eligible costs (€)	Justification of costs <i>description of expenditure and link to the specific work carried out (e.g. tasks, work packages, ...)</i>	
Personnel cost <sup>(2)</sup>			
Durable equipment			
Consumable and prototyping			
Travel	268,35	1 person Moskwa working session for WP4 INSTR	
		<b>N2-BENE - Beam for European Neutrino Experiments</b>	
		Total effort in person-months <sup>(1)</sup>	3
Cost category	Actual direct eligible costs (€)	Justification of costs <i>description of expenditure and link to the specific work carried out (e.g. tasks, work packages, ...)</i>	
Personnel cost <sup>(2)</sup>			
Durable equipment			
Consumable and prototyping			
Travel	4 253,66	1 person Ithaca WP2 sc driver, 1 person Cracow WP3 target, 1 person Geneva WP3 target	
		<b>R3- HIPPI - High Intensity Pulsed Proton Injector</b>	
		Total effort in person-months <sup>(1)</sup>	38
Cost category	Actual direct eligible costs (€)	Justification of costs <i>description of expenditure and link to the specific work carried out (e.g. tasks, work packages, ...)</i>	
Personnel cost <sup>(2)</sup>	232 887,18	permanent personnel salary for work on WP3 SC spoke and for work on WP5 BD. Electrostatic simulation of cavities, construction work on 352 MHz cavity, coupler design, investigation of beam dynamics issues, code development for cavity comparison. 50.610,69 Euro for temporary staff.	
Durable equipment	3 169,61	Equipment for cavity handling.	
Consumable and prototyping	43 810,15	design, construction and assembly of forming and supporting structures. Consumables for cavity mounting and cavity measurements	
Travel	14 535,18	5 persons Saclay WP3 meeting, 3 persons Milano HIPPI meeting, 2 persons Saclay cavity cleaning, 3 persons Abingdon WP5 meeting, 1 person Salzburg Computational Physics, 1 person Lyon DIPAC05, 1 person Knoxville (+Düsseldorf and Frankfurt) PAC05, 2 persons Hürth and Solingen cavity end caps, 1 person Frankfurt seminar, 5 persons Abingdon HIPPI05, 1 person Geneva CARE05, 1 person Paris cavity stiffening	
Total direct eligible costs	298 924,13		
Total indirect costs	245 756,30		
Total costs <sup>(3)</sup>	544 680,43	Global estimate of the total costs for AC contractors (not only the eligible costs)	

**Justify any deviations with respect to the planned budget**

1 temporary staff could be hired only starting in Sep05. 1 temporary staff could only be hired starting in Nov05  
Expected cost was 450 kEuro, more activity was performed than in 2004.

Adjustments to the previous period have been included in the individual activities and represent a total amount of **+8 441,97 euros**

<sup>(1)</sup> AC contractors must include both the total estimated human effort (including permanent staff) and, in brackets, additional staff only.

<sup>(2)</sup> For TA activities excluding the effort charged under the user fees if the UF cost model is used.

<sup>(3)</sup> Totals should correspond to the respective figures on FORM C - Financial Statement

B. MANAGEMENT REPORT (FINANCIAL INFORMATION)

Contract N°	RII3-CT-2003-506395	Project acronym	CARE
Participant N°	8	Participant short name	TUM
		<b>N2-BENE - Beam for European Neutrino Experiments</b>	
		Total effort in person-months <sup>(1)</sup>	0.5
Cost category	Actual direct eligible costs (€)	Justification of costs <i>description of expenditure and link to the specific work carried out (e.g. tasks, work packages, ...)</i>	
Personnel cost <sup>(2)</sup>			
Durable equipment			
Consumable and prototyping			
Travel	2 267,04	participation and presentation of BENE related material at two workshops: 'neutrino telescopes', Venice, Italy (22.-25.2.05, 1 person) and 'SUSY05', Durham, UK (18.-23.7.05, 1 person)	
Total direct eligible costs	2 267,04		
Total indirect costs	453,40		
Total costs <sup>(3)</sup>	2 720,44	Global estimate of the total costs for AC contractors (not only the eligible costs)	5000
<b>Justify any deviations with respect to the planned budget</b>			
received 16/1/2006			

<sup>(1)</sup> AC contractors must include both the total estimated human effort (including permanent staff) and, in brackets, additional staff only.

<sup>(2)</sup> For TA activities excluding the effort charged under the user fees if the UF cost model is used.

<sup>(3)</sup> Totals should correspond to the respective figures on FORM C - Financial Statement

B. MANAGEMENT REPORT (FINANCIAL INFORMATION)

<b>Contract N°</b>	<b>RII3-CT-2003-506395</b>	<b>Project acronym</b>	<b>CARE</b>
<b>Participant N°</b>	<b>9</b>	<b>Participant short name</b>	<b>FZR</b>
		<b>N1-ELAN - Electron Linear Accelerator Network</b>	
		<b>Total effort in person-months <sup>(1)</sup></b>	1.5 (0.0)
<b>Cost category</b>	<b>Actual direct eligible costs (€)</b>	<b>Justification of costs</b> description of expenditure and link to the specific work carried out (e.g. tasks, work packages, ...)	
<b>Personnel cost <sup>(2)</sup></b>			
<b>Durable equipment</b>			
<b>Consumable and prototyping</b>			
<b>Travel</b>	4 957,70	Participation in the SRF workshop, Ithaca (2 persons) and the CARE Annual meeting, Geneva (2 persons)	
		<b>R2-PHIN - Photo Injector</b>	
		<b>Total effort in person-months <sup>(1)</sup></b>	40 (18)
<b>Cost category</b>	<b>Actual direct eligible costs (€)</b>	<b>Justification of costs</b> description of expenditure and link to the specific work carried out (e.g. tasks, work packages, ...)	
<b>Personnel cost <sup>(2)</sup></b>	65 807,84	additional staff (temporary contracts), in 2004: 1 scientist working in WP 2, photocathode know-how, photocathode preparation equipment for 12 months, 1 scientist working in WP4, SC RF gun, for 6 months	
<b>Durable equipment</b>			
<b>Consumable and prototyping</b>	52 048,20	WP 2, photocathode preparation equipment: consumables for the installation of new equipment, for control electronics and WP 4, SC RF gun:	
<b>Travel</b>	1 644,96	WP 4: cost for ICFA Nanobeam workshop, Kyoto (1 person)	
<b>Total direct eligible costs</b>	<b>124 458,70</b>		
<b>Total indirect costs</b>	<b>24 891,74</b>		
<b>Total costs <sup>(3)</sup></b>	<b>149 350,44</b>	<b>Global estimate of the total costs for AC contractors (not only the eligible costs)</b>	227000
<b>Justify any deviations with respect to the planned budget</b>			

Received 17/1/2006

<sup>(1)</sup> AC contractors must include both the total estimated human effort (including permanent staff) and, in brackets, additional staff only.

<sup>(2)</sup> For TA activities excluding the effort charged under the user fees if the UF cost model is used.

<sup>(3)</sup> Totals should correspond to the respective figures on FORM C - Financial Statement

Contract N°	RII3-CT-2003-506395	Project acronym	CARE
Participant N°	10	Participant short name	INFN
		<b>N1-ELAN - Electron Linear Accelerator Network</b>	
		<b>Total effort in person-months <sup>(1)</sup></b>	3,5
<b>Cost category</b>	<b>Actual direct eligible costs (€)</b>	<b>Justification of costs</b> <i>description of expenditure and link to the specific work carried out (e.g. tasks, work packages, ...)</i>	
Personnel cost <sup>(2)</sup>			
Durable equipment			
Consumable and prototyping			
Travel	12 323,73	Workshop on "Positron Sources for the International Linear Collider", Daresbury (UK), April 05 (LNF 1 physicist); ILC European Regional meeting London, June 05 (LNF 2 physicists); "International Workshop on High Energy Electron Acceleration Using Plasmas", HEEAUP 2005, Paris, June 05 (LNF 1 physicist); 2nd ILC workshop at Snowmass (USA), August 05, studying and planning the linear collider program (LNF 1 physicist)	
		<b>N2-BENE - Beam for European Neutrino Experiments</b>	
		<b>Total effort in person-months <sup>(1)</sup></b>	6,0
<b>Cost category</b>	<b>Actual direct eligible costs (€)</b>	<b>Justification of costs</b> <i>description of expenditure and link to the specific work carried out (e.g. tasks, work packages, ...)</i>	
Personnel cost <sup>(2)</sup>			
Durable equipment			
Consumable and prototyping			
Travel	1 787,85	Neutrino Betabeam Meeting, Rutherford, 17-19 Jan 05 (NA 1 person); "Next Neutrino & Nucleon decay detector" Workshop NNN 05, Aussois (Fr), 6-8 Apr 05 (NA 1 person)	
		<b>N3-HHH - High Energy High Intensity Hadron Beams</b>	
		<b>Total effort in person-months <sup>(1)</sup></b>	3,0
<b>Cost category</b>	<b>Actual direct eligible costs (€)</b>	<b>Justification of costs</b> <i>description of expenditure and link to the specific work carried out (e.g. tasks, work packages, ...)</i>	
Personnel cost <sup>(2)</sup>			
Durable equipment			
Consumable and prototyping			
Travel	602,31	"2005 CARE-HHH-APD Workshop on Scenarios for the LHC Luminosity Upgrade" Arcidosso, Italy, 31 August-3 September 2005 (LNF 1 person)	

		<b>Total effort in person-months <sup>(1)</sup></b>	LNF 32,3 (9,5) LNL 36,2 (24,2) MI 30 (16) RMII 30 (24)
<b>Cost category</b>	<b>Actual direct eligible costs (€)</b>	<b>Justification of costs</b> <i>description of expenditure and link to the specific work carried out (e.g. tasks, work packages, ...)</i>	
<b>Personnel cost <sup>(2)</sup></b>	228 356,61	LNF: 2 physicists, 9.5 person-months for WP11 Beam diagnostics, screen and optics construction and installation; LNL: 1,6 person-months working for WP3,WP5 and WP6, 4,9 person-months working for WP3,WP5 and WP6; 6 person-months working for WP3,WP5 and WP6, 11,7 person-months working for WP3,WP5 and WP6; MI: (Laura Monaco: WP 2 Task 2.1 Reliability analysis and Task 2.2 Improved component design; Roberto Paulon: WP 2 Task 2.2 Improved component design and WP8 Task 8.1 UMI tuner; Nicola Panzeri - 85%: WP 2 Task 2.2 Improved component design and WP 8 Task 8.1 UMI tuner); RM II: 2 physicists, 24 person-months for WP4.2 – Planar-Arc Cathode Coating	
<b>Durable equipment</b>	3 817,98	Depreciation Costs for: LNF (1 Notebook WP11); LNL: 1 Switching Power Supply used for the AUTOMATED EP in WP5; RM II (1 Gaussmeter and 1 Laser Nd-YAG Lotis-Tii Mod. LS-2131)	
<b>Consumable and prototyping</b>	40 516,35	LNF € 7.937,00 (WP11: Optical elements, construction of mechanical support); RM II € 24.975,85 (WP4.2: Nitrogen injection line, UHV anode chamber, water cooled CF200 flange, OFHC copper disk substrates); MI € 7.603,50 (WP 2 Task 2.2 improved component design: Al gasket procurement, testing and analysis, strain gauges, WP8 Task 8.1 UMI tuner: piezo linear translators, liquid helium for tests and analysis software)	
<b>Travel</b>	15 351,66	LNF (4 Travels to DESY Hamburg: Installation of beam position monitor based on optical diffraction radiation); RM II ((JRA1/WP4 Meeting, Warsaw 8-9/2/2005 (1 scientist); SRF-2005 Workshop 10-15/7/2005, Cornell US (2 scientists); MI ( 1 Travel to Warsaw: CARE activity presentation at SPIE2005)	
		<b>R2-PHIN - Photo Injector</b>	
		<b>Total effort in person-months <sup>(1)</sup></b>	LNF 39,5 (13,5) MI 15 (7)
<b>Cost category</b>	<b>Actual direct eligible costs (€)</b>	<b>Justification of costs</b> <i>description of expenditure and link to the specific work carried out (e.g. tasks, work packages, ...)</i>	
<b>Personnel cost <sup>(2)</sup></b>	57 223,34	LNF: 2 physicists 13.5 person-months - CTF3 photoinjector studies; MI (Claudio Borghi; Luca Cultrera) 7 person-months - Laser pulse shaping	
<b>Durable equipment</b>			
<b>Consumable and prototyping</b>	25 145,79	LNF € 14.107,29 optical elements; MI € 11.038,50, optical elements for WP2: laser	
<b>Travel</b>			



		Total effort in person-months <sup>(1)</sup>	MI 16(8)
<b>Cost category</b>	<b>Actual direct eligible costs (€)</b>	<b>Justification of costs</b> <i>description of expenditure and link to the specific work carried out (e.g. tasks, work packages, ...)</i>	
Personnel cost <sup>(2)</sup>	16 289,74	MI (Marta Novati under WP 3 tasks 3.1.1 cavity specifications and WP 5 Task 5.1 code development; Nicola Panzeri - 15%, under WP 3: Tasks 3.1.2-3.1.3 piezo tuner design)	
Durable equipment			
Consumable and prototyping	0,00		
Travel	1 135,40	MI ( 1 Travel to Abingdon-UK, HIPPI05 Yearly meeting )	
		<b>R4- NED - Next European Dipole</b>	
		Total effort in person-months <sup>(1)</sup>	16(5)
<b>Cost category</b>	<b>Actual direct eligible costs (€)</b>	<b>Justification of costs</b> <i>description of expenditure and link to the specific work carried out (e.g. tasks, work packages, ...)</i>	
Personnel cost <sup>(2)</sup>	9 980,19	MI: 1 physicist 5 person-months	
Durable equipment			
Consumable and prototyping	0,00		
Travel	610,96	MI: 1 Travel to CERN, NED Steering Committee meeting, 19-21 Jan 05	
<b>Total direct eligible costs</b>	<b>413 141,91</b>		
<b>Total indirect costs</b>	<b>82 628,38</b>		
<b>Adjustments to previous periods</b>	<b>-17 677,08</b>	Plus: IRAP Tax on 2004 Personnel Costs; Travels done in 2004 but paid in 2005. Minus: Travels to CERN Accelerator School; Costs retained not eligible because are General Expenses and Dissemination; Costs retained not eligible by the auditor for which we are going to ask the opinion of UE Commission.	
<b>Total costs <sup>(3)</sup></b>	<b>478 093,21</b>	<b>Global estimate of the total costs for AC contractors (not only the eligible costs)</b>	<b>939 578,90</b>
<b>Justify any deviations with respect to the planned budget</b>			

<sup>(1)</sup> AC contractors must include both the total estimated human effort (including permanent staff) and, in brackets, additional staff only.

<sup>(2)</sup> For TA activities excluding the effort charged under the user fees if the UF cost model is used.

<sup>(3)</sup> Totals should correspond to the respective figures on FORM C - Financial Statement

Contract N°	RII3-CT-2003-506395	Project acronym	CARE
Participant N°	11	Participant short name	TEU
		<b>Management</b>	
		Total effort in person-months <sup>(1)</sup>	
Cost category	Actual direct eligible costs (€)	<b>Justification of costs</b> <i>description of expenditure and link to the specific work carried out (e.g. tasks, work packages, ...)</i>	
Audit certificate	814	audit certificate for 2004	
		<b>N3-HHH - High Energy High Intensity Hadron Beams</b>	
		Total effort in person-months <sup>(1)</sup>	
Cost category	Actual direct eligible costs (€)	<b>Justification of costs</b> <i>description of expenditure and link to the specific work carried out (e.g. tasks, work packages, ...)</i>	
Personnel cost <sup>(2)</sup>			
Durable equipment			
Consumable and prototyping			
Travel	1 624	HHH-AMT Workshop on Insulation systems, March 2005, CERN HHH-AMT workshop on Pulsed Magnets, Frascati-Rome Care central meeting at Cern	
		<b>R2- PHIN - Photo Injector</b>	
		Total effort in person-months <sup>(1)</sup>	4,8
Cost category	Actual direct eligible costs (€)	<b>Justification of costs</b> <i>description of expenditure and link to the specific work carried out (e.g. tasks, work packages, ...)</i>	
Personnel cost <sup>(2)</sup>	24 047	diagnostics photocathode preparation and photocathode preparation chamber.	
Durable equipment			
Consumable and prototyping	1 112	Small components and consumables.	
Travel			

		<b>R4- NED - Next European Dipole</b>	
		<b>Total effort in person-months <sup>(1)</sup></b>	<b>8</b>
<b>Cost category</b>	<b>Actual direct eligible costs (€)</b>	<b>Justification of costs</b> <i>description of expenditure and link to the specific work carried out (e.g. tasks, work packages, ...)</i>	
<b>Personnel cost <sup>(2)</sup></b>	47 402	WP1: JRA management, WP3: Management Workgroup on Conductor Characterisation + experiments and reporting conductor characterisation	
<b>Durable equipment</b>			
<b>Consumable and prototyping</b>	0,00	WP3: Experiments conductor characterisation	
<b>Travel</b>	1 782	1 person: 4 SC meetings, 1 WGCC meeting, CARE central meeting	
<b>Total direct eligible costs</b>	<b>76 781</b>		
<b>Total indirect costs</b>	<b>69 388</b>		
<b>Total costs <sup>(3)</sup></b>	<b>146 169</b>	<b>Global estimate of the total costs for AC contractors (not only the eligible costs)</b>	
<b>Justify any deviations with respect to the planned budget</b>			

<sup>(1)</sup> AC contractors must include both the total estimated human effort (including permanent staff) and, in brackets, additional staff only.

<sup>(2)</sup> For TA activities excluding the effort charged under the user fees if the UF cost model is used.

<sup>(3)</sup> Totals should correspond to the respective figures on FORM C - Financial Statement

Contract N°	RII3-CT-2003-506395	Project acronym	CARE
Participant N°	12 (AC)	Participant short name	TUL
		<b>N1-ELAN - Electron Linear Accelerator Network</b>	
		Total effort in person-months <sup>(1)</sup>	
Cost category	Actual direct eligible costs (€)	Justification of costs description of expenditure and link to the specific work carried out (e.g. tasks, work packages, ...)	
Personnel cost <sup>(2)</sup>			
Durable equipment			
Consumable and prototyping			
Travel	2 032	organization of CARE session during MIXDES 2005 conference, (June 2005, Cracow, Poland)	
		<b>R1-SRF - Superconducting Radio Frequency</b>	
		Total effort in person-months <sup>(1)</sup>	72(36)
Cost category	Actual direct eligible costs (€)	Justification of costs description of expenditure and link to the specific work carried out (e.g. tasks, work packages, ...)	
Personnel cost <sup>(2)</sup>	27 382	WP8: Task 8.2 (Magneto-strictive Tuner) 2 researchers (12 months each) - design, production and debugging of LLRF control board SIMCON3.1L for MT control; WP9: in total four researchers: Task 9.1.2 (LLRF Automation) Klystron FSM development (1 persons - 9 months), Klystron linearization (1 persons - 9 months), Task 9.2.2 (Radiation damage study) RadMon - system for on-line radiation monitoring, development and installation in VU-FEL tunnel (1 person - 12 months, 1 person - 9 months), Task 9.4.1 (Data management development) database for LLRF system settings integrated with DOOCS system (1 person - 9 months)	
Durable equipment			
Consumable and prototyping	93 235	WP8: Task 8.2 (Magneto-strictive Tuner) magneto-strictive rods for tuner construction, electronic components for SIMCON3.1L board; production of prototype of Simcon3.1L board, WP9: Task 9.2.2 (Radiation damage study) electronic components and materials for radiation tests, electronic components for RadMon (radiation monitoring system), production of prototype of RadMon boards	
Travel	9 669	WP8: 1) characterization and radiation experiments with piezzo and magnetostrictive tuner Participation in Paris, France (1 person); WP8&WP9: Participation in 1) RADECS Conference (September 2005) (1 person); 2) JRA 1 meeting, Legnaro, Italy (October 2005) (1 person); 3) Tesla Technology Collaboration Meeting, Frascati December 2005 (2 persons)	
Total direct eligible costs	132 317		
Total indirect costs	26 464		
Total costs <sup>(3)</sup>	158 781	Global estimate of the total costs for AC contractors (not only the eligible costs)	219 185
<i>Justify any deviations with respect to the planned budget</i>			
received 24/1/2006			

<sup>(1)</sup> AC contractors must include both the total estimated human effort (including permanent staff) and, in brackets, additional staff only.

<sup>(2)</sup> For TA activities excluding the effort charged under the user fees if the UF cost model is used.

<sup>(3)</sup> Totals should correspond to the respective figures on FORM C - Financial Statement

Contract N°	RII3-CT-2003-506395	Project acronym	CARE
Participant N°	13	Participant short name	IPJ
<b>Management</b>			
Total effort in person-months <sup>(1)</sup>			2,4
Cost category	Actual direct eligible costs (€)	Justification of costs description of expenditure and link to the specific work carried out (e.g. tasks, work packages, ...)	
Audit certificate	1 011,25	audit certificate	
<b>N1-ELAN - Electron Linear Accelerator Network</b>			
Total effort in person-months <sup>(1)</sup>			0,4 (0,2)
Cost category	Actual direct eligible costs (€)	Justification of costs description of expenditure and link to the specific work carried out (e.g. tasks, work packages, ...)	
Personnel cost <sup>(2)</sup>			
Durable equipment			
Consumable and prototyping			
Travel	3 042,25	ILC-Europ. Workshop London (2 p.) -19-24.06, SPIE Conf. Warsaw (2 p.) - 28.08-2.09.2005	
<b>R1-SRF - Superconducting Radio Frequency</b>			
Total effort in person-months <sup>(1)</sup>			83(12)
Cost category	Actual direct eligible costs (€)	Justification of costs description of expenditure and link to the specific work carried out (e.g. tasks, work packages, ...)	
Personnel cost <sup>(2)</sup>	12 148,00	additional staff - 1 scientist working in WP4 for 12 months	
Durable equipment	2 267,00	WP4; depreciation costs of turbomolecular pump ATP900 and camera CANON	
Consumable and prototyping	26 463,00	WP4; electric and technical materials/tools, measurement cards PCI6281, services	
Travel	8 095,00	Kudowa Zdroj-Int. Sch&Work (2p.) - 6-10.06, PLASMA 2005 (3p.) - 6-9.09, JRA1 Ann. M. (2 p.) - 16-21.10, Univ. Roma (3 p.) 13-22.05, CERN (2p)23-25.11.2005	
<b>Total direct eligible costs</b>	<b>53 026,50</b>		
<b>Total indirect costs</b>	<b>10 403,00</b>		
<b>Total costs <sup>(3)</sup></b>	<b>63 429,50</b>	<b>Global estimate of the total costs for AC contractors (not only the eligible costs)</b>	<b>€ 120 000</b>

Justify any deviations with respect to the planned budget

The verified total costs of WP4.1 in 2005 were EUR 63429,5, i.e. considerably lower than those estimated previously (EUR 130000 for 12 months), because of 3 reasons:

in addition to the sum above, EUR 7704,47 has been declared in the form C as an adjustment to the 2004 costs due to a correction of the conversion rate. The overall total costs is therefore 71133,97 euros.

1. The WP4.1 task leader became seriously sick in July 2005, and after a medical treatment and long stay at a hospital he is still recovering. It induced serious organization problems and it postponed the realization of some experimental tasks. 2. Laboratory tests of a prototype cylindrical magnetic filter (designed and manufactured for the elimination of micro-droplets) showed that its efficiency is too low. The second prototype filter is to be designed and prepared for tests within the linear (cylindrical) UHV-arc facility. According to the discussion with the JRA1 coordinators, as held during the recent CARE Annual Meeting at CERN, this milestone has been postponed by about 6 months, and it should be achieved in mid 2006.3. RF cavities made of high-purity copper (and appropriately prepared for the deposition of Nb layers) have not been delivered so far. According to declarations of the JRA1 coordinators, such cavities are to be manufactured within the collaboration of CERN, INFN-Legnaro and DESY. They should be delivered in mid 2006.

received 20/1/2006

<sup>(1)</sup> AC contractors must include both the total estimated human effort (including permanent staff) and, in brackets, additional staff only.

<sup>(2)</sup> For TA activities excluding the effort charged under the user fees if the UF cost model is used.

<sup>(3)</sup> Totals should correspond to the respective figures on FORM C - Financial Statement

Contract N°	RII3-CT-2003-506395	Project acronym	CARE
Participant N°	14	Participant short name	WUT-ISE
		<b>N1-ELAN - Electron Linear Accelerator Network</b>	
		Total effort in person-months <sup>(1)</sup>	
<b>Cost category</b>	<b>Actual direct eligible costs (€)</b>	<b>Justification of costs</b> description of expenditure and link to the specific work carried out (e.g. tasks, work packages, ...)	
Personnel cost <sup>(2)</sup>	0,00		
Durable equipment	0,00		
Consumable and prototyping	0,00		
Travel	3 754,21	Participation fee for 21 persons (WUT-ISE Lab team) - SPIE 2005 Conference in Warsaw - from 30th August until 2nd September	
		<b>R1- SRF - Superconducting Radio Frequency</b>	
		Total effort in person-months <sup>(1)</sup>	31,9 (22,3)
<b>Cost category</b>	<b>Actual direct eligible costs (€)</b>	<b>Justification of costs</b> description of expenditure and link to the specific work carried out (e.g. tasks, work packages, ...)	
Personnel cost <sup>(2)</sup>	40 663,86	Additional staff: 1 technician, 2 postgraduate students, 2 Ph.D. students, 1 engineer, 3 researchers. Design and tests of hardware LLRF blocks - WP9-T03 (23.991,31€). Realisation of software blocks WP9-T04 (10403,93€)	
Durable equipment	0,00		
Consumable and prototyping	52 492,63	Purchase of electronic (complete sub-assemblies, PCB, connectors, wires and cables) for LLRF blocks - WP9-T03	
Travel	22 431,44	Costs of the hotel of two persons from DESY visiting Warsaw for working and coordination talks 20-23 January 2005. Costs of the insurance for 11 persons from WUT-ISE Lab team participating in the LLRF Workshop in CERN 10-13 October 2005 (remaining costs of this participation were booked in October), Annual Meeting CARE in CERN	
<b>Total direct eligible costs</b>	<b>119 342,14</b>		
<b>Total indirect costs</b>	<b>23 868,43</b>		
<b>Total costs <sup>(3)</sup></b>	<b>143 210,57</b>	Global estimate of the total costs for AC contractors (not only the eligible costs)	<b>305 500,00</b>
<b>Justify any deviations with respect to the planned budget</b>			

<sup>(1)</sup> AC contractors must include both the total estimated human effort (including permanent staff) and, in brackets, additional staff only.

<sup>(2)</sup> For TA activities excluding the effort charged under the user fees if the UF cost model is used.

<sup>(3)</sup> Totals should correspond to the respective figures on FORM C - Financial Statement



Contract N°	RII3-CT-2003-506395	Project acronym	CARE
Participant N°	15	Participant short name	WUT
<b>N3-HHH - High Energy High Intensity Hadron Beams</b>			
		Total effort in person-months <sup>(1)</sup>	0.2(0.0)
Cost category	Actual direct eligible costs (€)	Justification of costs <i>description of expenditure and link to the specific work carried out (e.g. tasks, work packages, ...)</i>	
Personnel cost <sup>(2)</sup>			
Durable equipment			
Consumable and prototyping			
Travel	677,66	Participation in workshops, CERN (1 person)	
<b>R4- NED - Next European Dipole</b>			
		Total effort in person-months <sup>(1)</sup>	23.4(12)
Cost category	Actual direct eligible costs (€)	Justification of costs <i>description of expenditure and link to the specific work carried out (e.g. tasks, work packages, ...)</i>	
Personnel cost <sup>(2)</sup>	9 195,24	Two additional staff (temporary contracts) working for 6 months in WP2, cryostat commissioning, vacuum leak test, cold leak test, heat flux test to liquid helium	
Durable equipment	0,00		
Consumable and prototyping	6 378,90	WP2, the purchase and transport of liquid nitrogen and pipes and the purchase of materials for the frame bearer of the NED cryostat, assembly of the cryostat test	
Travel	339,27	Transport the cryostat to Saclay, (1 person)	
Total direct eligible costs	16 591,06		
Total indirect costs	3 318,21		
Total costs <sup>(3)</sup>	19 909,27	Global estimate of the total costs for AC contractors (not only the eligible costs)	61000
<i>Justify any deviations with respect to the planned budget</i>			
Received 8/2/2006			

<sup>(1)</sup> AC contractors must include both the total estimated human effort (including permanent staff) and, in brackets, additional staff only.

<sup>(2)</sup> For TA activities excluding the effort charged under the user fees if the UF cost model is used.

<sup>(3)</sup> Totals should correspond to the respective figures on FORM C - Financial Statement

B. MANAGEMENT REPORT (FINANCIAL INFORMATION)

Contract N°	RII3-CT-2003-506395	Project acronym	CARE
Participant N°	16	Participant short name	CSIC
		<b>Management</b>	
		Total effort in person-months <sup>(1)</sup>	
Cost category	Actual direct eligible costs (€)	Justification of costs description of expenditure and link to the specific work carried out (e.g. tasks, work packages, ...)	
Audit certificate	920,69	audit certificate 2004	
		<b>N1-ELAN - Electron Linear Accelerator Network</b>	
		Total effort in person-months <sup>(1)</sup>	5.0
Cost category	Actual direct eligible costs (€)	Justification of costs description of expenditure and link to the specific work carried out (e.g. tasks, work packages, ...)	
Personnel cost <sup>(2)</sup>			
Durable equipment			
Consumable and prototyping			
Travel	1 670,98	Participation in ELAN meeting London 20-23 June(2 people) and CARE General Meeting CERN 23-25 November(1 person). WP:BDYN	
		Total effort in person-months <sup>(1)</sup>	10.8
Cost category	Actual direct eligible costs (€)	Justification of costs description of expenditure and link to the specific work carried out (e.g. tasks, work packages, ...)	
Personnel cost <sup>(2)</sup>			
Durable equipment			
Consumable and prototyping			
Travel	6 666,95	Participation in BENE meetings CERN 17-20 March/ 21-24 September(3 people), NuFACT 21-26 June(3 people) and 17-20 June MICE (2 people). WP: Physcis	
		<b>N3-HHH - High Energy High Intensity Hadron Beams</b>	
		Total effort in person-months <sup>(1)</sup>	5.0
Cost category	Actual direct eligible costs (€)	Justification of costs description of expenditure and link to the specific work carried out (e.g. tasks, work packages, ...)	
Personnel cost <sup>(2)</sup>			
Durable equipment			
Consumable and prototyping			
Travel	1 000,00	Participation HHH meetings CERN 20-26 March(1 person), 25-27 October Frascati (1 person) and CARE General Meeting CERN 23-25 November (1person). WP: AMT	
Total direct eligible costs	10 258,62		
Total indirect costs			
Total costs <sup>(3)</sup>	10 258,62	Global estimate of the total costs for AC contractors (not only the eligible costs)	
<b>Justify any deviations with respect to the planned budget</b>			
<b>Received 17/1/2006</b>			

<sup>(1)</sup> AC contractors must include both the total estimated human effort (including permanent staff) and, in brackets, additional staff only.

<sup>(2)</sup> For TA activities excluding the effort charged under the user fees if the UF cost model is used.

<sup>(3)</sup> Totals should correspond to the respective figures on FORM C - Financial Statement

Contract N°	RII3-CT-2003-506395	Project acronym	CARE
Participant N°	17	Participant short name	CERN
		<b>N1-ELAN - Electron Linear Accelerator Network</b>	
		Total effort in person-months <sup>(1)</sup>	11(0)
Cost category	Actual direct eligible costs (€)	Justification of costs description of expenditure and link to the specific work carried out (e.g. tasks, work packages, ...)	
Personnel cost <sup>(2)</sup>	0,00		
Durable equipment			
Consumable and prototyping			
Travel	20 275,80	<p>Travel costs of the participants from CERN and Associate Institutes into:</p> <ul style="list-style-type: none"> <li>- the mid-year ELAN workshop (WS) joint to the European meeting on ILC in London (UK), to give a survey of the first-half 2005 network activities, coordinate efforts on beam instrumentation and dynamics, deals with the preparation of the future ILC efforts, 5 physicists from WP1&amp;WP3.</li> <li>- WS on wiggler design optimization at Frascati (IT), 6 physicists from WP1&amp;WP3.</li> <li>- WS on positron sources for ILC in Daresbury, 1 physicist from WP1.</li> <li>- WS on e- acceleration using plasmas in Paris, 2 physicists from Associate Institutes, 1 physicist from CERN</li> <li>- SPIE Europe Congress in Warsaw, talk on photoinjector, 1 physicist from WP1</li> <li>- Pulsed Power IEEE Conference in Monterey, USA, 1 physicist</li> <li>- ILC-GDE meeting in Oxford (UK), 1 engineer, 1 physicist from WP3.</li> <li>- ILC- first workshop, KEK (JA), 1 physicist</li> <li>- CARE04 meeting in Hamburg (D), 2 physicists (1 from Associate Institute)</li> <li>- ILC-GDE meeting in Frascati (I), 1 physicist, 1 engineer.</li> </ul>	
		<b>N2-BENE - Beam for European Neutrino Experiments</b>	
		Total effort in person-months <sup>(1)</sup>	15(0)
Cost category	Actual direct eligible costs (€)	Justification of costs description of expenditure and link to the specific work carried out (e.g. tasks, work packages, ...)	
Personnel cost <sup>(2)</sup>	0,00		
Durable equipment			
Consumable and prototyping			
Travel	15 305,30	<p>Travel costs of the participants into the following meetings :</p> <ol style="list-style-type: none"> <li>1. JOINT UK BENE Nuclear and Particle Physics meeting on the beta-beam, Rutherford Laboratory, January, 2005. Presentations: i) The beta-beam baseline ii) The EURISOL design study iii) The beta-beam task iv) Synergies with other tasks v) FFAG options vi) Tracking studies, 6 physicists, two of them invited from Canada (50% of costs covered by BENE).</li> <li>2. MICE collaboration and the American Muon Collaboration at LBNL in February, 2005: Presentation: Synergies of Targetry Experiment with Other Programs - n_TOF11. 1 physicist.</li> <li>3. Meeting on the future physics program at ZARAF, Israel, 2005: Beta-beam and ISOL techniques, 1 physicist</li> <li>4. Nufact05, Frascati, 2005: Working groups on Machines and on targets. Presentations: i) The technical challenges of Superbeams and Neutrino Physics ii) Targets WG plan and summary iii) An isochronous 10-20 GeV Muon Ring iv) Questions and challenges for the driver WG v) Beam dynamics in an isochronous FFAG ring vi) Technical challenges for the beta-beam and vii) How to optimize the beta-beam. 6 physicists.</li> <li>5. 2nd High Power Targetry Workshop at ORNL, October, 2005</li> <li>6. MERIT collaboration meeting at MIT, October 2005</li> <li>7. General BENE and ENG (European Neutrino Group) meetings in March &amp; August</li> <li>8. Seminar at Louvain-La-Neuve, May, 2005: The beta-beam, 2 physicists.</li> <li>9. Paris (Orsay), informal meetings on the beta-beam</li> <li>10. Grenoble, informal meeting and supervision at LPSC, 1 physicist</li> </ol>	

		<b>N3-HHH - High Energy High Intensity Hadron Beams</b>	
		<b>Total effort in person-months <sup>(1)</sup></b>	<b>30(0)</b>
<b>Cost category</b>	<b>Actual direct eligible costs (€)</b>	<b>Justification of costs</b> <i>description of expenditure and link to the specific work carried out (e.g. tasks, work packages, ...)</i>	
<b>Personnel cost <sup>(2)</sup></b>	0,00		
<b>Durable equipment</b>			
<b>Consumable and prototyping</b>			
<b>Travel</b>	34 357,98	Travel costs of the participants from CERN and Associate Institutes into: - WS (AMT) at CERN on 'heat deposition and quench level in SC magnets' 80 participants (6 of which fully supported by HHH) - WS (APD) at CERN on 'crystal collimation in hadron colliders' 80 participants (10 of which fully supported by HHH) - WS (AMT) at CERN on 'insulation and impregnation techniques' 70 participants (6 of which fully supported by HHH) - WS (APD) in Arcidosso - Italy on 'scenarios for the LHC luminosity upgrade' 40 specialists (14 of which fully supported by HHH) - WS (AMT) in Frascati - Italy on 'superconducting pulsed magnets for accelerators' 70 participants (6 of which fully supported by HHH) - Subsistence for two expert from USA visiting AMS WP specialists, one for 4 weeks the other for 2.5 weeks - Participation to WS organized by INFN (6 trips) USLARP(1trip) and University of Marsiglia(1 trip). - WS Ecomag, 3 participants supported by HHH.	
		<b>R2- PHIN - Photo Injector</b>	
		<b>Total effort in person-months <sup>(1)</sup></b>	<b>48(0)</b>
<b>Cost category</b>	<b>Actual direct eligible costs (€)</b>	<b>Justification of costs</b> <i>description of expenditure and link to the specific work carried out (e.g. tasks, work packages, ...)</i>	
<b>Personnel cost <sup>(2)</sup></b>	0,00	3 m/y staff + 1 m/y Fellow (all payed by CERN). WP1: participation to Steering committees, preparation of both technical and financial reports; organization of PHIN meeting. WP2: Preparation of the photocatode lab for production and calibration of thickness, preparation of drawings and tooling for XPS measurements WP3: Collaboration with RAL for the test of the oscillator, purchasing procedures for several component of the lasers, preparation of the laser room and of the beam path to the RG gun. Search for pockels cells drivers compatible with the phase coding specifications. WP4: Collaboration with LAL (several meetings and videoconferences) for the definition and the mechanical design of the RF gun for CTF3, preparation of the test line at CERN for the RF gun.	
<b>Durable equipment</b>			
<b>Consumable and prototyping</b>	722 473,64	miscellaneous material for laser test.1.5 Ghz Nd:Yif Oscillator. Diodes, drivers and mechanical mounting for first amplifier, informatic cards and software for the control system, miscellaneous material for the set-up of the laser at RAL. Miscellaneous material for the photocathode lab, including jackets for the bake-out of the test line, gases for the calibration of the mass spectrometer, different material on specification to CERN services and workshops.	
<b>Travel</b>	5 151,02	CARE steering committee in Paris, visit to RAL for oscillator acceptance test, visit to european companies in Laser 2005 in munich, visit to FID technologies in St. Petersburg for the phase coding pockels cell driver, IEEE international Pulsed Power conference+visite to SLAC	
		<b>R3- HIPPI - High Intensity Pulsed Proton Injector</b>	
		<b>Total effort in person-months <sup>(1)</sup></b>	<b>98 (24)</b>
<b>Cost category</b>	<b>Actual direct eligible costs (€)</b>	<b>Justification of costs</b> <i>description of expenditure and link to the specific work carried out (e.g. tasks, work packages, ...)</i>	

		<b>R4- NED - Next European Dipole</b>	
		<b>Total effort in person-months <sup>(1)</sup></b>	12(0)
<b>Cost category</b>	<b>Actual direct eligible costs (€)</b>	<b>Justification of costs</b> <i>description of expenditure and link to the specific work carried out (e.g. tasks, work packages, ...)</i>	
<b>Personnel cost <sup>(2)</sup></b>	0,00	only personnel payed by CERN (0.8 m/y staff and 0.2 m/y fellow). WP3: participation to Steering committees; preparation of both technical and financial reports; follow-up of the NED conductor development in industry; participation to the work of the Working Group on Conductor Characterization; Literature survey of the mechanical properties of the materials, micro-hardness and tensile measurements performed on strands at CERN, RRR measurements; metallographic preparations and observations of strands deformed by rolling.	
<b>Durable equipment</b>			
<b>Consumable and prototyping</b>	44 625,00	Payment of 15% of total contract amount placed to to SMI for Nb3Sn superconducting cable. The 15 % covers the conductor development carried out by SMI to increase the critical current density in the non copper part of the 192 filaments conductor to a value above 2500 A/mm <sup>2</sup> at 12 teslas and 4.2 K. Two strand lengths of 327 m and 320 m were delivered to CERN.	
<b>Travel</b>			
<b>Total direct eligible costs</b>	<b>976 503,63</b>		
<b>Total indirect costs</b>	<b>186 375,73</b>		
<b>Total costs <sup>(3)</sup></b>	<b>1 162 879,36</b>	<b>Global estimate of the total costs for AC contractors (not only the eligible costs)</b>	appr. 3,400,000
<b>Justify any deviations with respect to the planned budget</b>			
received 22/2/2006			

<sup>(1)</sup> AC contractors must include both the total estimated human effort (including permanent staff) and, in brackets, additional staff only.

<sup>(2)</sup> For TA activities excluding the effort charged under the user fees if the UF cost model is used.

<sup>(3)</sup> Totals should correspond to the respective figures on FORM C - Financial Statement

B. MANAGEMENT REPORT (FINANCIAL INFORMATION)

<b>Contract N°</b>	<b>RII3-CT-2003-506395</b>	<b>Project acronym</b>	<b>CARE</b>
<b>Participant N°</b>	<b>18</b>	<b>Participant short name</b>	<b>UniGE</b>
		<b>N2-BENE - Beam for European Neutrino Experiments</b>	
		<b>Total effort in person-months <sup>(1)</sup></b>	<b>7</b>
<b>Cost category</b>	<b>Actual direct eligible costs (€)</b>	<b>Justification of costs</b> <i>description of expenditure and link to the specific work carried out (e.g. tasks, work packages, ...)</i>	
<b>Personnel cost <sup>(2)</sup></b>			
<b>Durable equipment</b>			
<b>Consumable and prototyping</b>	859,94 €	BENE MegaWatt Workshop reprints	
<b>Travel</b>	9 354,08 €	BENE workshop DESY Nov 2004 (1 pers) ; muon cooling meetings in London 2004 (1 pers) ; in RAL (Janvier 2005) in Berkeley Lab feb 2005 (3 pers), BENE activities presentaiton at the Lisbon conference (1 pers) participation in NUFACT05 Frascati (3 pers); International sscoping study meeting july 2005 (1 pers); invitation expert to ISS meeting at CERN sept. 2005.	
		NB taux de conversion € -- CHF 1,5536	
<b>Total direct eligible costs</b>	10 214,02 €		
<b>Total indirect costs</b>	409,95 €		
<b>Total costs <sup>(3)</sup></b>	10 623,97 €	<b>Global estimate of the total costs for AC contractors (not only the eligible costs)</b>	
<b>Justify any deviations with respect to the planned budget</b>			

<sup>(1)</sup> AC contractors must include both the total estimated human effort (including permanent staff) and, in brackets, additional staff only.

<sup>(2)</sup> For TA activities excluding the effort charged under the user fees if the UF cost model is used.

<sup>(3)</sup> Totals should correspond to the respective figures on FORM C - Financial Statement

Contract N°	RII3-CT-2003-506395	Project acronym	CARE
Participant N°	19	Participant short name	PSI
		<b><i>N1-ELAN - Electron Linear Accelerator Network</i></b>	
		Total effort in person-months <sup>(1)</sup>	
Cost category	Actual direct eligible costs (€)	Justification of costs <i>description of expenditure and link to the specific work carried out (e.g. tasks, work packages, ...)</i>	
Personnel cost <sup>(2)</sup>			
Durable equipment			
Consumable and prototyping			
Travel	1 248,09	Travel Expenses for Network-Meetings: - 1 person JRA-1 Annual Meeting in Padua (18.-21. Okt 2005) - 1 person CARE Annual Meeting 2005 in Geneve (22.-25. Nov 2005)	
		<b><i>R1-SRF - Superconducting Radio Frequency</i></b>	
		Total effort in person-months <sup>(1)</sup>	14
Cost category	Actual direct eligible costs (€)	Justification of costs <i>description of expenditure and link to the specific work carried out (e.g. tasks, work packages, ...)</i>	
Personnel cost <sup>(2)</sup>	60 111,73	WP9 LLRF: - work at DESY within their LLRF-group for RF-gun control and evaluation of common HW-platforms to be used for RF control (1 CARE-person); - PSI-contributions: RF-Gun Regulation Concept, Evaluation Detectors, HW, SW, Firmware Support VPC-Board (several PSI persons)	
Durable equipment	23 191,25	RF Frequency Generator; VME-Lab.-Equipment and Hardware (PSI-contribution)	
Consumable and prototyping	1 944,95	VPC Prototype Board (PSI-contribution)	
Travel			
Total direct eligible costs	86 496,02		
Total indirect costs	4 639,08		
Total costs <sup>(3)</sup>	91 135,10	Global estimate of the total costs for AC contractors (not only the eligible costs)	
<b><i>Justify any deviations with respect to the planned budget</i></b>			

<sup>(1)</sup> AC contractors must include both the total estimated human effort (including permanent staff) and, in brackets, additional staff only.

<sup>(2)</sup> For TA activities excluding the effort charged under the user fees if the UF cost model is used.

<sup>(3)</sup> Totals should correspond to the respective figures on FORM C - Financial Statement



Contract N°	RII3-CT-2003-506395	Project acronym	CARE
Participant N°	20	Participant short name	CCLRC
		<b>N2-BENE - Beam for European Neutrino Experiments</b>	
		Total effort in person-months <sup>(1)</sup>	
<b>Cost category</b>	<b>Actual direct eligible costs (€)</b>	<b>Justification of costs</b> <i>description of expenditure and link to the specific work carried out (e.g. tasks, work packages, ...)</i>	
Personnel cost <sup>(2)</sup>			
Durable equipment			
Consumable and prototyping			
Travel	18 122,68	3 BENE meetings at CERN: (Mar, Aug & Nov, total 10 people); NuFact'05 (Jun, 4 people); ISS meeting at CERN (Sep, 10 people)	
		<b>N3-HHH - High Energy High Intensity Hadron Beams</b>	
		Total effort in person-months <sup>(1)</sup>	
<b>Cost category</b>	<b>Actual direct eligible costs (€)</b>	<b>Justification of costs</b> <i>description of expenditure and link to the specific work carried out (e.g. tasks, work packages, ...)</i>	
Personnel cost <sup>(2)</sup>			
Durable equipment			
Consumable and prototyping			
Travel	287,07	NED meeting at CERN (Mar05, 1 person)	
		<b>R2- PHIN - Photo Injector</b>	
		Total effort in person-months <sup>(1)</sup>	18,07
<b>Cost category</b>	<b>Actual direct eligible costs (€)</b>	<b>Justification of costs</b> <i>description of expenditure and link to the specific work carried out (e.g. tasks, work packages, ...)</i>	
Personnel cost <sup>(2)</sup>	76 945,04	1.5 staff months on WP1, 16.6 on WP3	
Durable equipment			
Consumable and prototyping	0,00		
Travel	6 587,36		
		<b>R3- HIPPI - High Intensity Pulsed Proton Injector</b>	
		Total effort in person-months <sup>(1)</sup>	30,94
<b>Cost category</b>	<b>Actual direct eligible costs (€)</b>	<b>Justification of costs</b> <i>description of expenditure and link to the specific work carried out (e.g. tasks, work packages, ...)</i>	
Personnel cost <sup>(2)</sup>	146 003,03	13.0 staff months on WP2, 15.7 on WP4, 2.2 on WP5	
Durable equipment			
Consumable and prototyping	62 807,42	Further engineering drawings and components for the Chopper	
Travel	7 464,30	HIPPI meetings at CERN (Jun) and RAL (Sep); various visits to suppliers; local HIPPI meetings (Mar, Aug)	

		<b>R4- NED - Next European Dipole</b>	
		<b>Total effort in person-months <sup>(1)</sup></b>	19,55
<b>Cost category</b>	<b>Actual direct eligible costs (€)</b>	<b>Justification of costs</b> <i>description of expenditure and link to the specific work carried out (e.g. tasks, work packages, ...)</i>	
<b>Personnel cost <sup>(2)</sup></b>	81 859,75	0.9 staff months on WP1, 3.3 on WP3, 15.4 on WP4	
<b>Durable equipment</b>			
<b>Consumable and prototyping</b>	19 598,35	WP4: chemicals for insulator construction; equipment for characterisation and testing	
<b>Travel</b>	10 356,39	NED meetings at CERN (Jan, Mar, Apr, Nov), Madrid (Jan), RAL (Jun) & Wroclaw (Jul)	

<b>Total direct eligible costs</b>	<b>430 031,39</b>		
<b>Total indirect costs</b>	<b>358 171,25</b>		
<b>Total costs <sup>(3)</sup></b>	<b>788 202,64</b>	<b>Global estimate of the total costs for AC contractors (not only the eligible costs)</b>	

**Justify any deviations with respect to the planned budget**

An adjustment of **+32 549, 73 euros** for the 2004 costs is to be added to the total 2005 costs: the total adjusted costs for 2005 is thus **820 752,37 euros**.

There is a lower than expected spend for both ELAN and HIPPI. For ELAN this is largely due to the continuing illness of the CCLRC coordinator. For HIPPI, it is due to a delay in recruitment arising from a problem obtaining a visa and the difficulty in finding a suitable candidate for another post.

The overspend for BENE is to compensate for an underspend in 2004.

**received 3/2/2006**

<sup>(1)</sup> AC contractors must include both the total estimated human effort (including permanent staff) and, in brackets, additional staff only.

<sup>(2)</sup> For TA activities excluding the effort charged under the user fees if the UF cost model is used.

<sup>(3)</sup> Totals should correspond to the respective figures on FORM C - Financial Statement

Contract N°	RII3-CT-2003-506395	Project acronym	CARE
Participant N°	21	Participant short name	ICL
<b>Management</b>			
		Total effort in person-months <sup>(1)</sup>	
Cost category	Actual direct eligible costs (€)	Justification of costs description of expenditure and link to the specific work carried out (e.g. tasks, work packages, ...)	
Audit certificate	726,43	Cost of audit certificate	
<b>N1-ELAN - Electron Linear Accelerator Network</b>			
		Total effort in person-months <sup>(1)</sup>	0.5(0)
Cost category	Actual direct eligible costs (€)	Justification of costs description of expenditure and link to the specific work carried out (e.g. tasks, work packages, ...)	
Personnel cost <sup>(2)</sup>			
Durable equipment			
Consumable and prototyping			
Travel	5 251,67	Participation in ELAN meetings (6 persons)	
<b>N2-BENE - Beam for European Neutrino Experiments</b>			
		Total effort in person-months <sup>(1)</sup>	1(0)
Cost category	Actual direct eligible costs (€)	Justification of costs description of expenditure and link to the specific work carried out (e.g. tasks, work packages, ...)	
Personnel cost <sup>(2)</sup>			
Durable equipment			
Consumable and prototyping			
Travel	21 006,69	Participation in NuFact05, Frascati (11 persons), ISS plenary meeting at CERN (8 persons), BENE meetings at CERN (10 persons)	
Total direct eligible costs	26 984,79		
Total indirect costs	5 251,67		
Total costs <sup>(3)</sup>	32 236,46	Global estimate of the total costs for AC contractors (not only the eligible costs)	5998,66
<b>Justify any deviations with respect to the planned budget</b>			
The difference between the planned budget and the actual costs in 2005 is due to the slow start up. The successful launch of the one-year international scoping study of a future Neutrino Factory and super-beam complex will increase the need for interaction between the various scientists who seek to contribute. It is therefore expected that the rate of expenditure will ramp up.			

<sup>(1)</sup> AC contractors must include both the total estimated human effort (including permanent staff) and, in brackets, additional staff only.

<sup>(2)</sup> For TA activities excluding the effort charged under the user fees if the UF cost model is used.

<sup>(3)</sup> Totals should correspond to the respective figures on FORM C - Financial Statement

Note : The costs on our Form C differ because the 726.43 Euros does not incur overheads but on this form there is no way to prevent this  
Cost statement summary:-

Management Costs - 726.43 Euros

Travel costs Direct - 26258.36 Euros

Indirect costs based on 20% of 26258.36 = 5251.67

Total Form C - 32236.46 Euros

B. MANAGEMENT REPORT (FINANCIAL INFORMATION)

<b>Contract N°</b>	-CT-2003-506395/DG	<b>Project acronym</b>	CARE
<b>Participant N°</b>	22	<b>Participant short name</b>	UMA
		<b>N1-ELAN - Electron Linear Accelerator Network</b>	
		<b>Total effort in person-months <sup>(1)</sup></b>	3(0)
<b>Cost category</b>	<b>Actual direct eligible costs (€)</b>	<b>Justification of costs</b> description of expenditure and link to the specific work carried out (e.g. tasks, work packages, ...)	
<b>Personnel cost <sup>(2)</sup></b>			
<b>Durable equipment</b>			
<b>Consumable and prototyping</b>			
<b>Travel</b>	9 119,71	3 ELAN meetings (1 person at Hamburg, 1 person at Frascati, 1 person at DESY), Plasma workshop HEEAUP05 (5 persons, Paris), ELAN-ILC meeting (10 persons, RHUL), ELAN meeting (1 person, DESY)	
<b>Total direct eligible costs</b>	9 119,71		
<b>Total indirect costs</b>	1823,94		
<b>Total costs <sup>(3)</sup></b>	10 943,65	<b>Global estimate of the total costs for AC contractors (not only the eligible costs)</b>	20 000
<b>Justify any deviations with respect to the planned budget</b>			

<sup>(1)</sup> AC contractors must include both the total estimated human effort (including permanent staff) and, in brackets, additional staff only.

<sup>(2)</sup> For TA activities excluding the effort charged under the user fees if the UF cost model is used.

<sup>(3)</sup> Totals should correspond to the respective figures on FORM C - Financial Statement

**2. Forms C - Financial Statements**

Form C – Financial Statements (Appendix 2)

## 1 CEA

**Form C - Model of Financial Statement per Activity for Integrated Infrastructure Initiatives**  
*(to be completed by each contractor)*

Type of instrument	Integrated Infrastructure Initiatives	Type of Action (if necessary)	I3
Project Title (or Acronym)	CARE	Contract n°	RII3-CT-2003-506395
Contractors's legal name	COMMISSARIAT A L'ENERGIE ATOMIQUE		
Legal Type	Governmental		
Contact Person	Roy Aleksan	Telephone	33 1 69083347
Telecopy	33 1 69086428	E-mail	aleksan@dapnia.cea.fr
Cost model used (AC/FC or FCF) (UF: User Fee)(*)	FC	Indirect costs (Real or Flat Rate of 20% of Direct costs, except subcontracting)	Real
Period from	01/01/2005	TO	31/12/2005

(\*) If UF is used under "other specific activities: transnational access/connectivity", please mention the two cost models used (eg. FC/UF or FCF/UF or AC/UF)

**1- Resources (Third party(ies))**

Are there any resources made available on the basis of a prior agreement with third parties identified in Annex I of the contract? (Yes / No)

NO

If Yes, please provide the following information

Third Party 1 (Y1)	Legal name	Cost model used
--------------------	------------	-----------------

If necessary add another Form C

**2- Declaration of eligible costs (in €)**

	Type of Activity												Total (G) = (A)+(B)+(C)+ (D)+(E)+(F)			
	Research and Technological Development / Innovation (A)		Demonstration (B)		Management of the Consortium (C)		Other Specific Activities: Coordination / Networking (D)		Other Specific Activities: Transnational Access / Connectivity (E)		Other Specific Activities (E)					
	Contractor	Third Party(ies)	Contractor	Third Party(ies)	Contractor	Third Party(ies)	Contractor	Third Party(ies)	Contractor	Third Party(ies)	Contractor	Third Party(ies)	Contractor	Third Party(ies)		
Direct costs	1 273 255,58	0	0	0	165 965,53	0	18 772,19	0	0	0	0	0	0	0	1 457 993,29	
<i>of which subcontracting</i>																
Indirect costs	799 287,39	0	0	0	120 188,50	0	0,00	0	0	0	0	0	0	0	919 475,89	
Adjustments to previous period(s)	-1 962,98														-1 962,98	
<b>Total costs</b>	<b>2 070 579,98</b>	<b>0,00</b>	<b>0,00</b>	<b>0,00</b>	<b>286 154,03</b>	<b>0,00</b>	<b>18 772,19</b>	<b>0,00</b>	<b>0,00</b>	<b>0,00</b>	<b>0,00</b>	<b>0,00</b>	<b>0,00</b>	<b>0,00</b>	<b>2 375 506,20</b>	

**3- Declaration of receipts (in €)**

If you are a contractor using the additional cost model (AC), indicate only receipts covered by Article II.23.c of the contract.

If you are a contractor using a full cost model (FC/FCF), indicate receipts covered by Article II.23 of the contract.

	Type of Activity												Total (G) = (A)+(B)+(C)+ (D)+(E)+(F)			
	Research and Technological Development / Innovation (A)		Demonstration (B)		Management of the Consortium (C)		Other Specific Activities: Coordination / Networking (D)		Specific Activities: Transnational Access / Connectivity (E)		Other Specific Activities (E)					
	Contractor	Third Party(ies)	Contractor	Third Party(ies)	Contractor	Third Party(ies)	Contractor	Third Party(ies)	Contractor	Third Party(ies)	Contractor	Third Party(ies)	Contractor	Third Party(ies)		
<b>Total receipts</b>																

<b>4- Declaration of interest generated by the pre-financing (in €)</b>	
<i>To be completed only by the coordinator.</i>	
<i>Did the pre-financing (advance) you received by the Commission for this period earn interest? (Yes / No)</i>	
<i>If yes, please indicate the amount (in €)</i>	

<b>5- Request of FP6 Financial Contribution (in €)</b>	
<i>For this period, the FP6 Community financial contribution requested is equal to ( amount in €)</i>	618 474

<b>6- Audit certificates</b>	
<i>According to the contract, does this Financial Statement need an audit certificate (or several in case of Third party(ies)) delivered by independent auditor(s)? (Yes / No)</i>	YES
<i>If Yes, does this(those) audit certificate(s) cover only this Financial Statement per Activity? (Yes / No)</i>	NO
<i>If No, what are the periods covered by this(those) audit certificate(s) ?</i>	From - to From 01/01/04 to 31/12/05
<i>What is the total cost of this(those) audit certificate(s) (in €) per independent auditor(s) ?</i>	

<b>Audit certificate of the contractor (X)</b>			
<b>Legal name of the audit firm</b>	<b>Salustro Reydel</b>	<b>Cost of the certificate</b>	
<b>Audit certificate(s) of the third party(ies) (Ys) (if necessary)</b>			
<b>Y1 : Legal name of the audit firm</b>		<b>Cost of the certificate</b>	
<b>If necessary add another Form C.</b>		<b>Total (Z) = (X) +</b>	
<i>Reminders:</i>			
<i>The cost of an audit certificate is included in the costs declared under the activity "Management of the Consortium". The required audit certificate (s) is (are) attached to this Financial Statement</i>			

<b>7- Conversion rates</b>	
Costs incurred in currencies other than EURO shall be reported in EURO.	
Please mention the conversion rate used (only one choice is possible) – Please note that the same principle applies for receipts.	
<b>Contractor</b>	
- Conversion rate of the date of incurred actual costs? (YES / NO)	
- Conversion rate of the first day of the first month following the period covered by this Financial Statement? (YES/NO)	
<b>Third Party(ies) (if necessary)</b>	
<b>Third Party 1 (Y1)</b>	
- Conversion rate of the date of incurred actual costs? (YES / NO)	
- Conversion rate of the first day of the first month following the period covered by this Financial Statement? (YES/NO)	

If necessary add another Form C.

<b>8- Contractor's Certificate</b>		
We certify that:		
- the costs declared above are directly related to the resources used to reach the objectives of the project ;		
- the receipts declared above are directly related to the resources used to reach the objectives of the project ;		
- the costs declared above fall within the definition of eligible costs specified in Articles II.19, II.20, II.21, II.22 and II.25 of the contract, and, if relevant, in Annex III and Article 9 (special clauses) of the contract ;		
- the receipts declared above fall within the definition of receipts specified in Article II.23 of the contract ;		
- the interest generated by the pre-financing declared above falls within the definition of Article II.27 of the contract ;		
- the necessary adjustments, especially to costs reported in previous Financial Statement(s) per Activity, have been incorporated in the above Statement ;		
- the above information declared is complete and true ;		
- there is full supporting documentation to justify the information hereby declared. It will be made available at the request of the Commission and in the event of an audit by the Commission and/or by the Court of Auditors and/or their authorised represen		
<b>Contractor's Stamp</b>	<b>Name of the Person responsible for the work</b>	<b>Name of the duly authorised Financial Officer</b>
	<b>Aleksan Roy</b>	<b>Boyer Muriel</b>
	<b>Date</b>	<b>Date</b>
	<b>02/01/2006</b>	<b>31/01/2006</b>
	<b>Signature</b>	<b>Signature</b>



## 2 UCLN

**Form C - Model of Financial Statement per Activity for Integrated Infrastructure Initiatives**  
*(to be completed by each contractor)*

Type of instrument	Integrated Infrastructure Initiatives	Type of Action (if necessary)	
Project Title (or Acronym)	CARE	Contract n°	RII-CT-2003-506395
Contractors's legal name	Universite Catholique de Louvain (UCL)		
Legal Type	PRIV		
Contact Person	Thierry Delbar	Telephone	(32)10473202
Telecopy	(32)10452183	E-mail	delbar@fynu.ucl.ac.be
Cost model used (AC/FC or FCF)/ (UF: User Fee)(*)	AC	Indirect costs (Real or Flat Rate of 20% of Direct costs, except subcontracting)	20%
Period from	01/01/2005	TO	31/12/2005

(\*) If UF is used under "other specific activities: transnational access/connectivity", please mention the two cost models used (eg. FC/UF or FCF/UF or AC/UF)

**1- Resources (Third party(ies))**

Are there any resources made available on the basis of a prior agreement with third parties identified in Annex I of the contract? (Yes / No)

No

If Yes, please provide the following information

Third Party 1 (Y1)	Legal name	Cost model used

If necessary add another Form C

**2- Declaration of eligible costs (in €)**

	Type of Activity													
	Research and Technological Development / Innovation		Demonstration		Management of the Consortium		Other Specific Activities: Coordination / Networking		Other Specific Activities: Transnational Access / Connectivity		Other Specific Activities		Total	
	(A)	(B)	(C)	(D)	(E)	(E)	(G) = (A)+(B)+(C)+(D)+(E)+(F)							
	Contractor	Third Party(ies)	Contractor	Third Party(ies)	Contractor	Third Party(ies)	Contractor	Third Party(ies)	Contractor	Third Party(ies)	Contractor	Third Party(ies)	Contractor	Third Party(ies)
Direct costs					300		1770,49						2 070,49	
Of which subcontracting														
Indirect costs							354,10						354,10	
Adjustments to previous period(s)														
<b>Total costs</b>					<b>300</b>		<b>2124,59</b>						<b>2 424,59</b>	

**3- Declaration of receipts (in €)**

If you are a contractor using the additional cost model (AC), indicate only receipts covered by Article II.23.c of the contract.

If you are a contractor using a full cost model (FC/FCF), indicate receipts covered by Article II.23 of the contract.

	Type of Activity													
	Research and Technological Development / Innovation		Demonstration		Management of the Consortium		Other Specific Activities: Coordination / Networking		Other Specific Activities: Transnational Access / Connectivity		Other Specific Activities		Total	
	(A)	(B)	(C)	(D)	(E)	(E)	(G) = (A)+(B)+(C)+(D)+(E)+(F)							
	Contractor	Third Party(ies)	Contractor	Third Party(ies)	Contractor	Third Party(ies)	Contractor	Third Party(ies)	Contractor	Third Party(ies)	Contractor	Third Party(ies)	Contractor	Third Party(ies)
<b>Total receipts</b>														0

<b>4- Declaration of interest generated by the pre-financing (in €)</b>	
<i>To be completed only by the coordinator.</i>	
<i>Did the pre-financing (advance) you received by the Commission for this period earn interest? (Yes / No)</i>	
<i>If yes, please indicate the amount (in €)</i>	

<b>5- Request of FP6 Financial Contribution (in €)</b>	
<i>For this period, the FP6 Community financial contribution requested is equal to ( amount in €)</i>	2 400,00

<b>6- Audit certificates</b>	
<i>According to the contract, does this Financial Statement need an audit certificate (or several in case of Third party(ies)) delivered by independent auditor(s)? (Yes / No)</i>	yes
<i>If Yes, does this(those) audit certificate(s) cover only this Financial Statement per Activity? (Yes / No)</i>	no
<i>If No, what are the periods covered by this(those) audit certificate(s) ?</i>	From - to 1-1-2004 to 31-12-2005
<i>What is the total cost of this(those) audit certificate(s) (in €) per independent auditor(s) ?</i>	300

<b>Audit certificate of the contractor (X)</b>			
<b>Legal name of the audit firm</b>	SPRL Pierre SOHET & C°	<b>Cost of the certificate</b>	300
<b>Audit certificate(s) of the third party(ies) (Ys) (if necessary)</b>			
<b>Y1 : Legal name of the audit firm</b>		<b>Cost of the certificate</b>	
<b>If necessary add another Form C.</b>		<b>Total (Z) = (X) + (Ys)</b>	300
<i>Reminders:</i>			
<i>The cost of an audit certificate is included in the costs declared under the activity "Management of the Consortium". The required audit certificate (s) is (are) attached to this Financial Statement</i>			

<b>7- Conversion rates</b>	
Costs incurred in currencies other than EURO shall be reported in EURO. Please mention the conversion rate used (only one choice is possible) – Please note that the same principle applies for receipts.	
<b>Contractor</b>	
- Conversion rate of the date of incurred actual costs? (YES / NO)	No
- Conversion rate of the first day of the first month following the period covered by this Financial Statement? (YES/NO)	No
<b>Third Party(ies) (if necessary)</b>	
<b>Third Party 1 (Y1)</b>	
- Conversion rate of the date of incurred actual costs? (YES / NO)	
- Conversion rate of the first day of the first month following the period covered by this Financial Statement? (YES/NO)	

If necessary add another Form C.

<b>8- Contractor's Certificate</b>		
We certify that:		
- the costs declared above are directly related to the resources used to reach the objectives of the project ;		
- the receipts declared above are directly related to the resources used to reach the objectives of the project ;		
- the costs declared above fall within the definition of eligible costs specified in Articles II.19, II.20, II.21, II.22 and II.25 of the contract, and, if relevant, in Annex III and Article 9 (special clauses) of the contract ;		
- the receipts declared above fall within the definition of receipts specified in Article II.23 of the contract ;		
- the interest generated by the pre-financing declared above falls within the definition of Article II.27 of the contract ;		
- the necessary adjustments, especially to costs reported in previous Financial Statement(s) per Activity, have been incorporated in the above Statement ;		
- the above information declared is complete and true ;		
- there is full supporting documentation to justify the information hereby declared. It will be made available at the request of the Commission and in the event of an audit by the Commission and/or by the Court of Auditors and/or their authorised representatives.		
<b>Contractor's Stamp</b>	<b>Name of the Person responsible for the work</b>	<b>Name of the duly authorised Financial Officer</b>
	<b>Thierry DELBAR</b>	<b>Brigitte BOSSUT</b>
	<b>Date</b>	<b>Date</b>
	<b>30/01/2006</b>	<b>30/01/2006</b>
	<b>Signature</b>	<b>Signature</b>

## 3 CNRS

**Form C - Model of Financial Statement per Activity for Integrated Infrastructure Initiatives**  
*(to be completed by each contractor)*

Type of instrument	<b>Integrated Infrastructure Initiatives</b>	Type of Action (if necessary)	
Project Title (or Acronym)	CARE	Contract n°	506395
Contractors's legal name	CNRS		
Legal Type	gov		
Contact Person	Terence Garvey	Telephone	33 1 64 46 89 61
Telecopy	01 64 46 83 62	E-mail	garvey@lal.in2p3.fr
Cost model used (AC/FC or FCF/ (UF: User Fee)(*)	FCF	Indirect costs (Real or Flat Rate of 20% of Direct costs, except subcontracting)	20%
Period from	01/01/2005	To	31/12/2005

(\*) If UF is used under "other specific activities: transnational access/connectivity", please mention the two cost models used (eg. FC/UF or FCF/UF or AC/UF)

**1- Resources (Third party(ies))**

Are there any resources made available on the basis of a prior agreement with third parties identified in Annex I of the contract? (Yes / No)	
If Yes, please provide the following information	
Third Party 1 (Y1)	Legal name
	Cost model used
If necessary add another Form C	

**2- Declaration of eligible costs (in €)**

	Type of Activity												Total (G) = (A)+(B)+(C)+ (D)+(E)+(F)		
	Research and Technological Development / Innovation (A)		Demonstration (B)		Management of the Consortium (C)		Other Specific Activities: Coordination / Networking (D)		Other Specific Activities: Transnational Access / Connectivity (E)		Other Specific Activities (F)				
	Contractor	Third Party(ies)	Contractor	Third Party(ies)	Contractor	Third Party(ies)	Contractor	Third Party(ies)	Contractor	Third Party(ies)	Contractor	Third Party(ies)	Contractor	Third Party(ies)	
Direct costs	1 241 937,76				0,00		16 582,62							1 258 520,38	
<i>Of which subcontracting</i>															
Indirect costs	248 387,55				0,00		3 316,52							251 704,07	
Adjustments to previous period(s)	8 563,23				0,00		-0,10							8 563,13	
<b>Total costs</b>	<b>1 498 888,54</b>	<b>0,00</b>	<b>0,00</b>	<b>0,00</b>	<b>0,00</b>	<b>0,00</b>	<b>19 899,04</b>	<b>0,00</b>	<b>0,00</b>	<b>0,00</b>	<b>0,00</b>	<b>0,00</b>	<b>0,00</b>	<b>1 518 787,58</b>	<b>0,00</b>

**3- Declaration of receipts (in €)**

If you are a contractor using the additional cost model (AC), indicate only receipts covered by Article II.23.c of the contract.

If you are a contractor using a full cost model (FC/FCF), indicate receipts covered by Article II.23 of the contract.

	Type of Activity												Total (G) = (A)+(B)+(C)+ (D)+(E)+(F)		
	Research and Technological Development / Innovation (A)		Demonstration (B)		Management of the Consortium (C)		Other Specific Activities: Coordination / Networking (D)		Other Specific Activities: Transnational Access / Connectivity (E)		Other Specific Activities (F)				
	Contractor	Third Party(ies)	Contractor	Third Party(ies)	Contractor	Third Party(ies)	Contractor	Third Party(ies)	Contractor	Third Party(ies)	Contractor	Third Party(ies)	Contractor	Third Party(ies)	
<b>Total receipts</b>															

<b>4- Declaration of interest generated by the pre-financing (in €)</b>	
<i>To be completed only by the coordinator.</i>	
Did the pre-financing (advance) you received by the Commission for this period earn interest? (Yes / No)	
If yes, please indicate the amount (in €)	

<b>5- Request of FP6 Financial Contribution (in €)</b>	
For this period, the FP6 Community financial contribution requested is equal to ( amount in €)	769 343,31

<b>6- Audit certificates</b>	
According to the contract, does this Financial Statement need an audit certificate (or several in case of Third party(ies)) delivered by independent auditor(s)? (Yes / No)	yes
If Yes, does this(those) audit certificate(s) cover only this Financial Statement per Activity? (Yes / No)	NO
If No, what are the periods covered by this(those) audit certificate(s) ?	From - to 01/01/2004 - 31/12/2005
What is the total cost of this(those) audit certificate(s) (in €) per independent auditor(s) ?	

<b>Audit certificate of the contractor (X)</b>			
Legal name of the audit firm	CNRS, Agent Comptable Principal	Cost of the certificate	0
<b>Audit certificate(s) of the third party(ies) (Ys) (if necessary)</b>			
Y1 : Legal name of the audit firm		Cost of the certificate	
<i>If necessary add another Form C.</i>		Total (Z) = (X) + (Ys)	
<i>Reminders:</i>			
<i>The cost of an audit certificate is included in the costs declared under the activity "Management of the Consortium". The required audit certificate (s) is (are) attached to this Financial Statement</i>			

<b>7- Conversion rates</b>	
Costs incurred in currencies other than EURO shall be reported in EURO.	
Please mention the conversion rate used (only one choice is possible) – Please note that the same principle applies for receipts.	
<b>Contractor</b>	
- Conversion rate of the date of incurred actual costs? (YES / NO)	
- Conversion rate of the first day of the first month following the period covered by this Financial Statement? (YES/NO)	
<b>Third Party(ies) (if necessary)</b>	
<b>Third Party 1 (Y1)</b>	
- Conversion rate of the date of incurred actual costs? (YES / NO)	
- Conversion rate of the first day of the first month following the period covered by this Financial Statement? (YES/NO)	

If necessary add another Form C.

<b>8- Contractor's Certificate</b>		
We certify that:		
- the costs declared above are directly related to the resources used to reach the objectives of the project ;		
- the receipts declared above are directly related to the resources used to reach the objectives of the project ;		
- the costs declared above fall within the definition of eligible costs specified in Articles II.19, II.20, II.21, II.22 and II.25 of the contract, and, if relevant, in Annex III and Article 9 (special clauses) of the contract ;		
- the receipts declared above fall within the definition of receipts specified in Article II.23 of the contract ;		
- the interest generated by the pre-financing declared above falls within the definition of Article II.27 of the contract ;		
- the necessary adjustments, especially to costs reported in previous Financial Statement(s) per Activity, have been incorporated in the above Statement ;		
- the above information declared is complete and true ;		
- there is full supporting documentation to justify the information hereby declared. It will be made available at the request of the Commission and in the event of an audit by the Commission and/or by the Court of Auditors and/or their authorised representatives.		
<b>Contractor's Stamp</b>	<b>Name of the Person responsible for the work</b>	<b>Name of the duly authorised Financial Officer</b>
	<b>T. Garvey</b>	<b>M. Dorin-Gerald</b>
	<b>Date</b>	<b>Date</b>
	<b>13/02/2006</b>	<b>13/02/2006</b>
	<b>Signature</b>	<b>Signature</b>

**Form C - Model of Financial Statement per Activity for Integrated Infrastructure Initiatives**  
(to be completed by each contractor)

Type of instrument	<b>Integrated Infrastructure Initiatives</b>	Type of Action (if necessary)	
Project Title (or Acronym)	<b>CARE</b>	Contract n°	<b>506395</b>
Contractors's legal name	<b>CNRS</b>		
Legal Type	<b>gov</b>		
Contact Person	<b>Terence Garvey</b>	Telephone	<b>33 1 64 46 89 61</b>
Telecopy	<b>01 64 46 83 62</b>	E-mail	<b>garvey@lal.in2p3.fr</b>
Cost model used (AC/FC or FCF)/ (UF: User Fee)(*)	<b>FCF</b>	Indirect costs (Real or Flat Rate of 20% of Direct costs, except subcontracting)	<b>20%</b>
Period from	<b>01/01/2005</b>	To	<b>31/12/2005</b>

(\*) If UF is used under "other specific activities: transnational access/connectivity", please mention the two cost models used (eg. FC/UF or FCF/UF or AC/UF)

**1- Resources (Third party(ies))**

Are there any resources made available on the basis of a prior agreement with third parties identified in Annex I of the contract? (Yes / No) yes

If Yes, please provide the following information

Third Party / JRA 1 (Y1)	Legal name	<b>Université Paris Sud</b>	Cost model used	<b>FCF</b>
Third Party 2 (Y2)	Legal name		Cost model used	

If necessary add another Form C

**2- Declaration of eligible costs (in €)**

	Type of Activity													
	Research and Technological Development / Innovation (A)		Demonstration (B)		Management of the Consortium (C)		Other Specific Activities: Coordination / Networking (D)		Other Specific Activities: Transnational Access / Connectivity (E)		Other Specific Activities (F)		Total (G) = (A)+(B)+(C)+(D)+(E)+(F)	
	Contractor	Third Party(ies)	Contractor	Third Party(ies)	Contractor	Third Party(ies)	Contractor	Third Party(ies)	Contractor	Third Party(ies)	Contractor	Third Party(ies)	Contractor	Third Party(ies)
Direct costs		8 787,44						33 932,47						42 719,91
Of which subcontracting														
Indirect costs		1 757,49						6 786,49						8 543,98
Adjustments to previous period(s)		5 157,64						27 627,31						32 784,95
<b>Total costs</b>	0,00	15 702,57	0,00	0,00	0,00	0,00	0,00	68 346,27	0,00	0,00	0,00	0,00		84 048,84

**3- Declaration of receipts (in €)**

If you are a contractor using the additional cost model (AC), indicate only receipts covered by Article II.23.c of the contract.

If you are a contractor using a full cost model (FC/FCF), indicate receipts covered by Article II.23 of the contract.

	Type of Activity													
	Research and Technological Development / Innovation		Demonstration		Management of the Consortium		Other Specific Activities: Coordination / Networking		Other Specific Activities: Transnational Access / Connectivity		Other Specific Activities		Total (G) =	
	Contractor	Third Party(ies)	Contractor	Third Party(ies)	Contractor	Third Party(ies)	Contractor	Third Party(ies)	Contractor	Third Party(ies)	Contractor	Third Party(ies)	Contractor	Third Party(ies)
<b>Total receipts</b>														

B. MANAGEMENT REPORT (FINANCIAL INFORMATION)

<b>4- Declaration of interest generated by the pre-financing (in €)</b>	
<i>To be completed only by the coordinator.</i>	
Did the pre-financing (advance) you received by the Commission for this period earn interest? (Yes / No)	
If yes, please indicate the amount (in €)	

<b>5- Request of FP6 Financial Contribution (in €)</b>	
For this period, the FP6 Community financial contribution requested is equal to ( amount in €)	76 197,56

<b>6- Audit certificates</b>	
According to the contract, does this Financial Statement need an audit certificate (or several in case of Third party(ies)) delivered by independent auditor(s)? (Yes / No)	
If Yes, does this(those) audit certificate(s) cover only this Financial Statement per Activity? (Yes / No)	
If No, what are the periods covered by this(those) audit certificate(s) ?	From - to
What is the total cost of this(those) audit certificate(s) (in €) per independent auditor(s) ?	

Audit certificate of the contractor (X)	
Legal name of the audit firm	CNRS, Agent Comptable Principal
Cost of the certificate	
Audit certificate(s) of the third party(ies) (Ys) (if necessary)	
Y1 : Legal name of the audit firm	
Cost of the certificate	
Y4 : Legal name of the audit firm	
Cost of the certificate	
<b>If necessary add another Form C.</b>	<b>Total (Z) = (X) + (Ys)</b>
<b>Reminders:</b>	
The cost of an audit certificate is included in the costs declared under the activity "Management of the Consortium". The required audit certificate (s) is (are) attached to this Financial Statement	

<b>7- Conversion rates</b>	
Costs incurred in currencies other than EURO shall be reported in EURO.	
Please mention the conversion rate used (only one choice is possible) – Please note that the same principle applies for receipts.	
Contractor	
- Conversion rate of the date of incurred actual costs? (YES / NO)	
- Conversion rate of the first day of the first month following the period covered by this Financial Statement? (YES/NO)	
Third Party(ies) (if necessary)	
Third Party 1 (Y1)	
- Conversion rate of the date of incurred actual costs? (YES / NO)	
- Conversion rate of the first day of the first month following the period covered by this Financial Statement? (YES/NO)	
If necessary add another Form C.	

<b>8- Contractor's Certificate</b>		
We certify that:		
- the costs declared above are directly related to the resources used to reach the objectives of the project ;		
- the receipts declared above are directly related to the resources used to reach the objectives of the project ;		
- the costs declared above fall within the definition of eligible costs specified in Articles II.19, II.20, II.21, II.22 and II.25 of the contract, and, if relevant, in Annex III and Article 9 (special clauses) of the contract ;		
- the receipts declared above fall within the definition of receipts specified in Article II.23 of the contract ;		
- the interest generated by the pre-financing declared above falls within the definition of Article II.27 of the contract ;		
- the necessary adjustments, especially to costs reported in previous Financial Statement(s) per Activity, have been incorporated in the above Statement ;		
- the above information declared is complete and true ;		
- there is full supporting documentation to justify the information hereby declared. It will be made available at the request of the Commission and in the event of an audit by the Commission and/or by the Court of Auditors and/or their authorised representatives.		
Contractor's Stamp	Name of the Person responsible for the work	Name of the duly authorised Financial Officer
	<b>T. Garvey</b>	<b>M. Brigitte Renard</b>
	Date	Date
	<b>19/02/2006</b>	<b>19/01/1900</b>
	Signature	Signature

## 4 GSI

**Form C - Model of Financial Statement per Activity for Integrated Infrastructure Initiatives**  
*(to be completed by each contractor)*

Type of instrument	Integrated Infrastructure Initiatives	Type of Action (if necessary)	
Project Title (or Acronym)	CARE/JRA HIPPI	Contract n°	RII-CT-2003-506395
Contractors's legal name	Gesellschaft für Schwerionenforschung mbH (GSI)		
Legal Type	GmbH limited liability company		
Contact Person	Dr. Lars Groening	Telephone	0049 6159 71 2344
Telecopy		E-mail	la.groening@gsi.de
Cost model used (AC/FC or FCF) (UF: User Fee)(*)	FC	Indirect costs (Real or Flat Rate of 20% of Direct costs, except subcontracting)	
Period from	01/01/2005	TO	31/12/2005

(\*) If UF is used under "other specific activities: transnational access/connectivity", please mention the two cost models used (eg. FC/UF or FCF/UF or AC/UF)

**1- Resources (Third party(ies))**

Are there any resources made available on the basis of a prior agreement with third parties identified in Annex I of the contract? (Yes / No) No

If Yes, please provide the following information

Third Party 1 (Y1)	Legal name	Cost model used

If necessary add another Form C

**2- Declaration of eligible costs (in €)**

	Type of Activity												Total (G) = (A)+(B)+(C)+ (D)+(E)+(F)		
	Research and Technological Development / Innovation (A)		Demonstration (B)		Management of the Consortium (C)		Other Specific Activities: Coordination / Networking (D)		Other Specific Activities: Transnational Access / Connectivity (E)		Other Specific Activities (E)				
	Contractor	Third Party(ies)	Contractor	Third Party(ies)	Contractor	Third Party(ies)	Contractor	Third Party(ies)	Contractor	Third Party(ies)	Contractor	Third Party(ies)	Contractor	Third Party(ies)	
Direct costs	218 843,48						6 035,05							224 878,53	
Of which subcontracting															
Indirect costs	36 615,06													36 615,06	
Adjustments to previous period(s)	-9 434,30						523,04								
<b>Total costs</b>	<b>246 024,24</b>						<b>6 558,09</b>							<b>252 582,33</b>	

**3- Declaration of receipts (in €)**

If you are a contractor using the additional cost model (AC), indicate only receipts covered by Article II.23.c of the contract.

If you are a contractor using a full cost model (FC/FCF), indicate receipts covered by Article II.23 of the contract.

	Type of Activity												Total (G) = (A)+(B)+(C)+ (D)+(E)+(F)		
	Research and Technological Development / Innovation (A)		Demonstration (B)		Management of the Consortium (C)		Other Specific Activities: Coordination / Networking (D)		Other Specific Activities: Transnational Access / Connectivity (E)		Other Specific Activities (E)				
	Contractor	Third Party(ies)	Contractor	Third Party(ies)	Contractor	Third Party(ies)	Contractor	Third Party(ies)	Contractor	Third Party(ies)	Contractor	Third Party(ies)	Contractor	Third Party(ies)	
<b>Total receipts</b>														0	



<b>4- Declaration of interest generated by the pre-financing (in €)</b>	
<i>To be completed only by the coordinator.</i>	
<i>Did the pre-financing (advance) you received by the Commission for this period earn interest? (Yes / No)</i>	
<i>If yes, please indicate the amount (in €)</i>	

<b>5- Request of FP6 Financial Contribution (in €)</b>	
<i>For this period, the FP6 Community financial contribution requested is equal to ( amount in €),received</i>	50 000,00

<b>6- Audit certificates</b>	
<i>According to the contract, does this Financial Statement need an audit certificate (or several in case of Third party(ies)) delivered by independent auditor(s)? (Yes / No)</i>	YES
<i>If Yes, does this(those) audit certificate(s) cover only this Financial Statement per Activity? (Yes / No)</i>	NO
<i>If No, what are the periods covered by this(those) audit certificate(s) ?</i>	From - to 01.01.2004-31.12.2005
<i>What is the total cost of this(those) audit certificate(s) (in €) per independent auditor(s) ?</i>	3500 €

<b>Audit certificate of the contractor (X)</b>			
<b>Legal name of the audit firm</b>	internal revision	<b>Cost of the certificate</b>	
<b>Audit certificate(s) of the third party(ies) (Ys) (if necessary)</b>			
<b>Y1 : Legal name of the audit firm</b>		<b>Cost of the certificate</b>	
<b>If necessary add another Form C.</b>		<b>Total (Z) = (X) + (Ys)</b>	
<i>Reminders:</i>			
<i>The cost of an audit certificate is included in the costs declared under the activity "Management of the Consortium". The required audit certificate (s) is (are) attached to this Financial Statement</i>			

<b>7- Conversion rates</b>	
Costs incurred in currencies other than EURO shall be reported in EURO.	
Please mention the conversion rate used (only one choice is possible) – Please note that the same principle applies for receipts.	
<b>Contractor</b>	
- Conversion rate of the date of incurred actual costs? (YES / NO)	No
- Conversion rate of the first day of the first month following the period covered by this Financial Statement? (YES/NO)	No
<b>Third Party(ies) (if necessary)</b>	
<b>Third Party 1 (Y1)</b>	
- Conversion rate of the date of incurred actual costs? (YES / NO)	
- Conversion rate of the first day of the first month following the period covered by this Financial Statement? (YES/NO)	

If necessary add another Form C.

<b>8- Contractor's Certificate</b>		
We certify that:		
- the costs declared above are directly related to the resources used to reach the objectives of the project ;		
- the receipts declared above are directly related to the resources used to reach the objectives of the project ;		
- the costs declared above fall within the definition of eligible costs specified in Articles II.19, II.20, II.21, II.22 and II.25 of the contract, and, if relevant, in Annex III and Article 9 (special clauses) of the contract ;		
- the receipts declared above fall within the definition of receipts specified in Article II.23 of the contract ;		
- the interest generated by the pre-financing declared above falls within the definition of Article II.27 of the contract ;		
- the necessary adjustments, especially to costs reported in previous Financial Statement(s) per Activity, have been incorporated in the above Statement ;		
- the above information declared is complete and true ;		
- there is full supporting documentation to justify the information hereby declared. It will be made available at the request of the Commission and in the event of an audit by the Commission and/or by the Court of Auditors and/or their authorised representatives.		
<b>Contractor's Stamp</b>	<b>Name of the Person responsible for the work</b>	<b>Name of the duly authorised Financial Officer</b>
	<b>Dr. Lars Groening</b>	<b>Annette Städter</b>
	<b>Date</b>	<b>Date</b>
	<b>31/01/2005</b>	<b>31/01/2005</b>
	<b>Signature</b>	<b>Signature</b>

## 5 IAP-FU

**Form C - Model of Financial Statement per Activity for Integrated Infrastructure Initiatives**  
*(to be completed by each contractor)*

Type of instrument	Integrated Infrastructure Initiatives	Type of Action (if necessary)	
Project Title (or Acronym)	CARE	Contract n°	RII3-CT-2003-506395
Contractors's legal name	Johann Wolfgang Goethe Universität Frankfurt am Main		
Legal Type	Public research body organized under the laws of Germany		
Contact Person	Dr. Susanne Eickemeier	Telephone	+ 49 69 798 22130
Telecopy	+ 49 69 798 25007	E-mail	u.ratzinger@iap.uni-frankfurt.c
Cost model used (AC/FC or FCF)/ (UF; User Fee)(*)	AC	Indirect costs (Real or Flat Rate of 20% of Direct costs, except subcontracting)	20%
Period from	1.01.2005	TO	31.12.2005

(\*) If UF is used under "other specific activities: transnational access/connectivity", please mention the two cost models used (eg. FC/UF or FCF/UF or AC/UF)

**1- Resources (Third party(ies))**

Are there any resources made available on the basis of a prior agreement with third parties identified in Annex I of the contract? (Yes / No)

If Yes, please provide the following information

Third Party 1 (Y1)	Legal name	Cost model used

If necessary add another Form C

**2- Declaration of eligible costs (in €)**

	Type of Activity													
	Research and Technological Development / Innovation (A)		Demonstration (B)		Management of the Consortium (C)		Other Specific Activities: Coordination / Networking (D)		Other Specific Activities: Transnational Access / Connectivity (E)		Other Specific Activities (E)		Total (G) = (A)+(B)+(C)+(D)+(E)+(F)	
	Contractor	Third Party(ies)	Contractor	Third Party(ies)	Contractor	Third Party(ies)	Contractor	Third Party(ies)	Contractor	Third Party(ies)	Contractor	Third Party(ies)	Contractor	Third Party(ies)
Direct costs	69 378,39				566,94									69 945,33
Of which subcontracting														0,00
Indirect costs	13 875,68													13 875,68
Adjustments to previous period(s)														0,00
<b>Total costs</b>	<b>83 254,07</b>				<b>566,94</b>									<b>83 821,01</b>

**3- Declaration of receipts (in €)**

If you are a contractor using the additional cost model (AC), indicate only receipts covered by Article II.23.c of the contract.

If you are a contractor using a full cost model (FC/FCF), indicate receipts covered by Article II.23 of the contract.

	Type of Activity													
	Research and Technological Development / Innovation (A)		Demonstration (B)		Management of the Consortium (C)		Other Specific Activities: Coordination / Networking (D)		Other Specific Activities: Transnational Access / Connectivity (E)		Other Specific Activities (E)		Total (G) = (A)+(B)+(C)+(D)+(E)+(F)	
	Contractor	Third Party(ies)	Contractor	Third Party(ies)	Contractor	Third Party(ies)	Contractor	Third Party(ies)	Contractor	Third Party(ies)	Contractor	Third Party(ies)	Contractor	Third Party(ies)
<b>Total receipts</b>														

<b>4- Declaration of interest generated by the pre-financing (in €)</b>	
<i>To be completed only by the coordinator.</i>	
<i>Did the pre-financing (advance) you received by the Commission for this period earn interest? (Yes / No)</i>	
<i>If yes, please indicate the amount (in €)</i>	

<b>5- Request of FP6 Financial Contribution (in €)</b>	
<i>For this period, the FP6 Community financial contribution requested is equal to ( amount in €)</i>	83 821,01

<b>6- Audit certificates</b>	
<i>According to the contract, does this Financial Statement need an audit certificate (or several in case of Third party(ies)) delivered by independent auditor(s)? (Yes / No)</i>	<b>Yes</b>
<i>If Yes, does this(those) audit certificate(s) cover only this Financial Statement per Activity? (Yes / No)</i>	<b>Yes</b>
<i>If No, what are the periods covered by this(those) audit certificate(s) ?</i>	1/1/2004 - 31/12/2005
<i>What is the total cost of this(those) audit certificate(s) (in €) per independent auditor(s) ?</i>	566,94

<b>Audit certificate of the contractor (X)</b>			
<b>Legal name of the audit firm</b>	<b>Interne Revision - Frankf. Univ</b>	<b>Cost of the certificate</b>	<b>566,94</b>
<b>Audit certificate(s) of the third party(ies) (Ys) (if necessary)</b>			
<b>Y1 : Legal name of the audit firm</b>		<b>Cost of the certificate</b>	
<b>If necessary add another Form C.</b>		<b>Total (Z) = (X) + (Ys)</b>	
<i>Reminders:</i>			
<i>The cost of an audit certificate is included in the costs declared under the activity "Management of the Consortium". The required audit certificate (s) is (are) attached to this Financial Statement</i>			

<b>7- Conversion rates</b>	
Costs incurred in currencies other than EURO shall be reported in EURO.	
Please mention the conversion rate used (only one choice is possible) – Please note that the same principle applies for receipts.	
<b>Contractor</b>	
- Conversion rate of the date of incurred actual costs? (YES / NO)	
- Conversion rate of the first day of the first month following the period covered by this Financial Statement? (YES/NO)	
<b>Third Party(ies) (if necessary)</b>	
<b>Third Party 1 (Y1)</b>	
- Conversion rate of the date of incurred actual costs? (YES / NO)	
- Conversion rate of the first day of the first month following the period covered by this Financial Statement? (YES/NO)	

If necessary add another Form C.

<b>8- Contractor's Certificate</b>		
We certify that:		
- the costs declared above are directly related to the resources used to reach the objectives of the project ;		
- the receipts declared above are directly related to the resources used to reach the objectives of the project ;		
- the costs declared above fall within the definition of eligible costs specified in Articles II.19, II.20, II.21, II.22 and II.25 of the contract, and, if relevant, in Annex III and Article 9 (special clauses) of the contract ;		
- the receipts declared above fall within the definition of receipts specified in Article II.23 of the contract ;		
- the interest generated by the pre-financing declared above falls within the definition of Article II.27 of the contract ;		
- the necessary adjustments, especially to costs reported in previous Financial Statement(s) per Activity, have been incorporated in the above Statement ;		
- the above information declared is complete and true ;		
- there is full supporting documentation to justify the information hereby declared. It will be made available at the request of the Commission and in the event of an audit by the Commission and/or by the Court of Auditors and/or their authorised representatives.		
<b>Contractor's Stamp</b>	<b>Name of the Person responsible for the work</b>	<b>Name of the duly authorised Financial Officer</b>
	<b>Prof. U. Ratzinger</b>	<b>S. Eickemeier</b>
	<b>Date</b>	<b>Date</b>
	<b>01/02/2006</b>	<b>02/02/2006</b>
	<b>Signature</b>	<b>Signature</b>

## 6 DESY

**Form C - Model of Financial Statement per Activity for Integrated Infrastructure Initiatives**  
*(to be completed by each contractor)*

Type of Instrument	Integrated Infrastructure Initiatives	Type of Action (if necessary)	
Project Title (or Acronym)	CARE	Contract n°	RII3-CT-2003-506395
Contractors's legal name	Stiftung Deutsches Elektronen-Synchrotron		
Legal Type			
Contact Person	Prof. Dr. Dieter Proch	Telephone	(+49)-40-8998-3273
Telecopy	(+49)-40-8998-4302	E-mail	dieter.proch@desy.de
Cost model used (AC/FC or FCF)/ (UF: User Fee)(*)	AC	Indirect costs (Real or Flat Rate of 20% of Direct costs, except subcontracting)	Flat rate 20%
Period from	01/01/2005	TO	31/12/2005

(\*) If UF is used under "other specific activities: transnational access/connectivity", please mention the two cost models used (eg. FC/UF or FCF/UF or AC/UF)

**1- Resources (Third party(ies))**

Are there any resources made available on the basis of a prior agreement with third parties identified in Annex I of the contract? (Yes / No)

No

If Yes, please provide the following information

Third Party 1 (Y1)	Legal name	Cost model used

If necessary add another Form C

**2- Declaration of eligible costs (in €)**

	Type of Activity												Total (G) = (A)+(B)+(C)+ (D)+(E)+(F)		
	Research and Technological Development / Innovation (A)		Demonstration (B)		Management of the Consortium (C)		Other Specific Activities: Coordination / Networking (D)		Other Specific Activities: Transnational Access / Connectivity (E)		Other Specific Activities (E)				
	Contractor	Third Party(ies)	Contractor	Third Party(ies)	Contractor	Third Party(ies)	Contractor	Third Party(ies)	Contractor	Third Party(ies)	Contractor	Third Party(ies)	Contractor	Third Party(ies)	
Direct costs	377 219,48						51 381,18							428 600,66	
Of which subcontracting	27 650,00													27 650,00	
Indirect costs	69 913,90						10 276,24							80 190,13	
Adjustments to previous period(s)	-23 768,36						1 067,09							-22 701,27	
<b>Total costs</b>	<b>423 365,02</b>						<b>62 724,51</b>							<b>486 089,52</b>	

**3- Declaration of receipts (in €)**

If you are a contractor using the additional cost model (AC), indicate only receipts covered by Article II.23.c of the contract.

If you are a contractor using a full cost model (FC/FCF), indicate receipts covered by Article II.23 of the contract.

	Type of Activity												Total (G) = (A)+(B)+(C)+ (D)+(E)+(F)		
	Research and Technological Development / Innovation (A)		Demonstration (B)		Management of the Consortium (C)		Other Specific Activities: Coordination / Networking (D)		Other Specific Activities: Transnational Access / Connectivity (E)		Other Specific Activities (E)				
	Contractor	Third Party(ies)	Contractor	Third Party(ies)	Contractor	Third Party(ies)	Contractor	Third Party(ies)	Contractor	Third Party(ies)	Contractor	Third Party(ies)	Contractor	Third Party(ies)	
<b>Total receipts</b>															

<b>4- Declaration of interest generated by the pre-financing (in €)</b>	
<i>To be completed only by the coordinator.</i>	
Did the pre-financing (advance) you received by the Commission for this period earn interest? (Yes / No)	
If yes, please indicate the amount (in €)	

<b>5- Request of FP6 Financial Contribution (in €)</b>	
For this period, the FP6 Community financial contribution requested is equal to ( amount in €)	486 089,52

<b>6- Audit certificates</b>	
According to the contract, does this Financial Statement need an audit certificate (or several in case of Third party(ies)) delivered by independent auditor(s)? (Yes / No)	Yes
If Yes, does this(those) audit certificate(s) cover only this Financial Statement per Activity? (Yes / No)	No
If No, what are the periods covered by this(those) audit certificate(s) ?	From - to 01.01.2004 - 31.12.2005
What is the total cost of this(those) audit certificate(s) (in €) per independent auditor(s) ?	1.199,21

Audit certificate of the contractor (X)			
Legal name of the audit firm	DESY Internal Auditor	Cost of the certificate	1 199,21
Audit certificate(s) of the third party(ies) (Ys) (if necessary)			
Y1 : Legal name of the audit firm		Cost of the certificate	
If necessary add another Form C.		Total (Z) = (X) + (Ys)	
Reminders: The cost of an audit certificate is included in the costs declared under the activity "Management of the Consortium". The required audit certificate (s) is (are) attached to this Financial Statement			

<b>7- Conversion rates</b>	
Costs incurred in currencies other than EURO shall be reported in EURO.	
Please mention the conversion rate used (only one choice is possible) – Please note that the same principle applies for receipts.	
Contractor	
- Conversion rate of the date of incurred actual costs? (YES / NO)	No
- Conversion rate of the first day of the first month following the period covered by this Financial Statement? (YES/NO)	
Third Party(ies) (if necessary)	
Third Party 1 (Y1)	
- Conversion rate of the date of incurred actual costs? (YES / NO)	
- Conversion rate of the first day of the first month following the period covered by this Financial Statement? (YES/NO)	

If necessary add another Form C.

<b>8- Contractor's Certificate</b>		
We certify that:		
- the costs declared above are directly related to the resources used to reach the objectives of the project ;		
- the receipts declared above are directly related to the resources used to reach the objectives of the project ;		
- the costs declared above fall within the definition of eligible costs specified in Articles II.19, II.20, II.21, II.22 and II.25 of the contract, and, if relevant, in Annex III and Article 9 (special clauses) of the contract ;		
- the receipts declared above fall within the definition of receipts specified in Article II.23 of the contract ;		
- the interest generated by the pre-financing declared above falls within the definition of Article II.27 of the contract ;		
- the necessary adjustments, especially to costs reported in previous Financial Statement(s) per Activity, have been incorporated in the above Statement ;		
- the above information declared is complete and true ;		
- there is full supporting documentation to justify the information hereby declared. It will be made available at the request of the Commission and in the event of an audit by the Commission and/or by the Court of Auditors and/or their authorised representatives.		
Contractor's Stamp	Name of the Person responsible for the work	Name of the duly authorised Financial Officer
	<b>Dr. Dieter Proch</b>	<b>Uwe Wolframm</b>
	Date	Date
	<b>01-févr-06</b>	<b>01-févr-06</b>
	Signature	Signature

## 7 FZJ

**Form C - Model of Financial Statement per Activity for Integrated Infrastructure Initiatives**  
(to be completed by each contractor)

Type of instrument	Integrated Infrastructure Initiatives	Type of Action (if necessary)	
Project Title (or Acronym)	CARE	Contract n°	RII3-CT-2003-506395
Contractor's legal name	Forschungszentrum Juelich GmbH		
Legal Type	GmbH		
Contact Person	Dr. Raimund Tölle	Telephone	+49-2461-615615
Telecopy	+49-2461-612670	E-mail	r.toelle@fz-juelich.de
Cost model used (AC/FC or FCF)/ (UF: User Fee)(*)	FC	Indirect costs (Real or Flat Rate of 20% of Direct costs, except subcontracting)	Real
Period from	01.01.2005	To	31.12.2005

(\*) If UF is used under "other specific activities: transnational access/connectivity", please mention the two cost models used (eg. FC/UF or FCF/UF or AC/UF)

**1- Resources (Third party(ies))**

Are there any resources made available on the basis of a prior agreement with third parties identified in Annex I of the contract? (Yes / No) No

If Yes, please provide the following information

Third Party (Y1)	Legal name	Cost model used
Third Party 2 (Y2)	Legal name	Cost model used
Third Party 3 (Y3)	Legal name	Cost model used
Third Party 4 (Y4)	Legal name	Cost model used

If necessary add another Form C

**2- Declaration of eligible costs (in €)**

Please complete only the activity covered by the relevant instrument (and type of action) indicated above and as mentioned in Article II.25 and/or in Annexes I and III of the contract.

If you are a contractor using the additional cost model (AC):

- indica

	Type of Activity												Total (G) = (A)+(B)+(C)+ (D)+(E)+(F)		
	Research and Technological Development / Innovation (A)		Demonstration (B)		Management of the Consortium (C)		Other Specific Activities: Coordination / Networking (D)		Other Specific Activities: Transnational Access / Connectivity (E)		Other Specific Activities (E)				
	Contractor	Third Party(ies)	Contractor	Third Party(ies)	Contractor	Third Party(ies)	Contractor	Third Party(ies)	Contractor	Third Party(ies)	Contractor	Third Party(ies)	Contractor	Third Party(ies)	
Direct costs	312.508,27						4.339,79							316.848,06	0,00
Of which subcontracting														0,00	0,00
Indirect costs	219.390,39													219.390,39	0,00
Adjustments to previous period(s)	8.487,44						-46,47							8.441,97	0,00
<b>Total costs</b>	<b>540.386,11</b>	<b>0,00</b>	<b>0,00</b>	<b>0,00</b>	<b>0,00</b>	<b>0,00</b>	<b>4.294,32</b>	<b>0,00</b>	<b>0,00</b>	<b>0,00</b>	<b>0,00</b>	<b>0,00</b>	<b>0,00</b>	<b>544.680,43</b>	<b>0,00</b>

**3- Declaration of receipts (in €)**

If you are a contractor using the additional cost model (AC), indicate only receipts covered by Article II.23.c of the contract.

If you are a contractor using a full cost model (FC/FCF), indicate receipts covered by Article II.23 of the contract.

	Type of Activity												Total (G) = (A)+(B)+(C)+ (D)+(E)+(F)		
	Research and Technological Development / Innovation (A)		Demonstration (B)		Management of the Consortium (C)		Other Specific Activities: Coordination / Networking (D)		Other Specific Activities: Transnational Access / Connectivity (E)		Other Specific Activities (E)				
	Contractor	Third Party(ies)	Contractor	Third Party(ies)	Contractor	Third Party(ies)	Contractor	Third Party(ies)	Contractor	Third Party(ies)	Contractor	Third Party(ies)	Contractor	Third Party(ies)	
<b>Total receipts</b>														0	0



<b>4- Declaration of interest generated by the pre-financing (in €)</b>	
<i>To be completed only by the coordinator.</i>	
Did the pre-financing (advance) you received by the Commission for this period earn interest? (Yes / No)	
If yes, please indicate the amount (in €)	


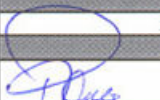
<b>5- Request of FP6 Financial Contribution (in €)</b>	
For this period, the FP6 Community financial contribution requested is equal to ( amount in €)	<b>129.447,74</b>

<b>6- Audit certificates</b>	
According to the contract, does this Financial Statement need an audit certificate (or several in case of Third party(ies)) delivered by independent auditor(s)? (Yes / No)	Yes
If Yes, does this(those) audit certificate(s) cover only this Financial Statement per Activity? (Yes / No)	No
If No, what are the periods covered by this(those) audit certificate(s) ?	From - to <b>01.01.04 - 31.12.05</b>
What is the total cost of this(those) audit certificate(s) (in €) per independent auditor(s) ?	

Audit certificate of the contractor (X)			
Legal name of the audit firm	<b>Ernst &amp; Young AG</b>	Cost of the certificate	2.500,00 (decl. next period!)
Audit certificate(s) of the third party(ies) (Ys) (if necessary)			
Y1 : Legal name of the audit firm		Cost of the certificate	
Y2 : Legal name of the audit firm		Cost of the certificate	
Y3 : Legal name of the audit firm		Cost of the certificate	
Y4 : Legal name of the audit firm		Cost of the certificate	
If necessary add another Form C.		Total (Z) = (X) + (Ys)	
Reminders: The cost of an audit certificate is included in the costs declared under the activity "Management of the Consortium". The required audit certificate (s) is (are) attached to this Financial Statement			

<b>7- Conversion rates</b>	
Costs incurred in currencies other than EURO shall be reported in EURO.	
Please mention the conversion rate used (only one choice is possible) – Please note that the same principle applies for receipts.	
Contractor	
- Conversion rate of the date of incurred actual costs? (YES / NO)	Yes
- Conversion rate of the first day of the first month following the period covered by this Financial Statement? (YES/NO)	No

Third Party(ies) (if necessary)	
Third Party 1 (Y1)	
- Conversion rate of the date of incurred actual costs? (YES / NO)	
- Conversion rate of the first day of the first month following the period covered by this Financial Statement? (YES/NO)	
If necessary add another Form C.	

<b>8- Contractor's Certificate</b>		
We certify that:		
- the costs declared above are directly related to the resources used to reach the objectives of the project ;		
- the receipts declared above are directly related to the resources used to reach the objectives of the project ;		
- the costs declared above fall within the definition of eligible costs specified in Articles II.19, II.20, II.21, II.22 and II.25 of the contract, and, if relevant, in Annex III and Article 9 (special clauses) of the contract ;		
- the receipts declared above fall within the definition of receipts specified in Article II.23 of the contract ;		
- the interest generated by the pre-financing declared above falls within the definition of Article II.27 of the contract ;		
- the necessary adjustments, especially to costs reported in previous Financial Statement(s) per Activity, have been incorporated in the above Statement ;		
- the above information declared is complete and true ;		
- there is full supporting documentation to justify the information hereby declared. It will be made available at the request of the Commission and in the event of an audit by the Commission and/or by the Court of Auditors and/or their authorised represen		
Contractor's Stamp	Name of the Person responsible for the work	Name of the duly authorised Financial Officer
	<b>Dr. Raimund Tölle</b>	<b>i.A. Elke Philipp</b> <b>i.A. Fritz Sommer</b>
	Date	Date
	<b>20.01.2006</b>	<b>20.01.2006</b>
	Signature	Signature
		

**FORSCHUNGSZENTRUM JÜLICH GMBH**  
 - Geschäftsbereich Finanzen -  
 F-K / Projektbuchung  
 52429 Jülich  
 Fracht-/Paketanschrift: Leo-Brandt-Str., 52429 Jülich



## 8 TUM

**Form C - Model of Financial Statement per Activity for Integrated Infrastructure Initiatives**  
*(to be completed by each contractor)*

Type of instrument	Integrated Infrastructure Initiatives	Type of Action (if necessary)	
Project Title (or Acronym)	CARE	Contract n°	RII-CT-2003-506395
Contractors's legal name	Technical University of München		
Legal Type			
Contact Person	Manfred Lindner	Telephone	+49 89 289 12196
Telecopy	(49) 89 289 14583	E-mail	lindner@ph.tum.de
Cost model used (AC/FC or FCF)/ (UF: User Fee)(*)	AC	Indirect costs (Real or Flat Rate of 20% of Direct costs, except subcontracting)	20%
Period from	01/01/2005	TO	31/12/2005

(\*) If UF is used under "other specific activities: transnational access/connectivity", please mention the two cost models used (eg. FC/UF or FCF/UF or AC/UF)

**1- Resources (Third party(ies))**

Are there any resources made available on the basis of a prior agreement with third parties identified in Annex I of the contract? (Yes / No)

No

If Yes, please provide the following information

Third Party 1 (Y1)	Legal name	Cost model used
--------------------	------------	-----------------

If necessary add another Form C

**2- Declaration of eligible costs (in €)**

	Type of Activity													
	Research and Technological Development / Innovation		Demonstration		Management of the Consortium		Other Specific Activities: Coordination / Networking		Other Specific Activities: Transnational Access / Connectivity		Other Specific Activities		Total	
	(A)	(B)	(C)	(D)	(E)	(E)	(G) = (A)+(B)+(C)+(D)+(E)+(F)							
	Contractor	Third Party(ies)	Contractor	Third Party(ies)	Contractor	Third Party(ies)	Contractor	Third Party(ies)	Contractor	Third Party(ies)	Contractor	Third Party(ies)	Contractor	Third Party(ies)
Direct costs									2267,04					2267,04
Of which subcontracting														
Indirect costs									453,40					453,40
Adjustments to previous period(s)														
<b>Total costs</b>									<b>2 720,44</b>					<b>2 720,44</b>

**3- Declaration of receipts (in €)**

If you are a contractor using the additional cost model (AC), indicate only receipts covered by Article II.23.c of the contract.

If you are a contractor using a full cost model (FC/FCF), indicate receipts covered by Article II.23 of the contract.

	Type of Activity													
	Research and Technological Development / Innovation		Demonstration		Management of the Consortium		Other Specific Activities: Coordination / Networking		Other Specific Activities: Transnational Access / Connectivity		Other Specific Activities		Total	
	(A)	(B)	(C)	(D)	(E)	(E)	(G) = (A)+(B)+(C)+(D)+(E)+(F)							
	Contractor	Third Party(ies)	Contractor	Third Party(ies)	Contractor	Third Party(ies)	Contractor	Third Party(ies)	Contractor	Third Party(ies)	Contractor	Third Party(ies)	Contractor	Third Party(ies)
<b>Total receipts</b>														0

<b>4- Declaration of interest generated by the pre-financing (in €)</b>	
<i>To be completed only by the coordinator.</i>	
<i>Did the pre-financing (advance) you received by the Commission for this period earn interest? (Yes / No)</i>	
<i>If yes, please indicate the amount (in €)</i>	

<b>5- Request of FP6 Financial Contribution (in €)</b>	
<i>For this period, the FP6 Community financial contribution requested is equal to ( amount in €)</i>	<b>2 720,44</b>

<b>6- Audit certificates</b>	
<i>According to the contract, does this Financial Statement need an audit certificate (or several in case of Third party(ies)) delivered by independent auditor(s)? (Yes / No)</i>	Yes
<i>If Yes, does this(those) audit certificate(s) cover only this Financial Statement per Activity? (Yes / No)</i>	No
<i>If No, what are the periods covered by this(those) audit certificate(s) ?</i>	From - to <b>01/01/2004 - 31/12/2005</b>
<i>What is the total cost of this(those) audit certificate(s) (in €) per independent auditor(s) ?</i>	

<b>Audit certificate of the contractor (X)</b>			
<b>Legal name of the audit firm</b>		<b>Cost of the certificate</b>	
<b>Audit certificate(s) of the third party(ies) (Ys) (if necessary)</b>			
<b>Y1 : Legal name of the audit firm</b>		<b>Cost of the certificate</b>	
<b>If necessary add another Form C.</b>		<b>Total (Z) = (X) + (Ys)</b>	
<b>Reminders:</b>			
<i>The cost of an audit certificate is included in the costs declared under the activity "Management of the Consortium". The required audit certificate (s) is (are) attached to this Financial Statement</i>			

<b>7- Conversion rates</b>	
Costs incurred in currencies other than EURO shall be reported in EURO.	
Please mention the conversion rate used (only one choice is possible) – Please note that the same principle applies for receipts.	
<b>Contractor</b>	
<i>- Conversion rate of the date of incurred actual costs? (YES / NO)</i>	No
<i>- Conversion rate of the first day of the first month following the period covered by this Financial Statement? (YES/NO)</i>	No
<b>Third Party(ies) (if necessary)</b>	
<b>Third Party 1 (Y1)</b>	
<i>- Conversion rate of the date of incurred actual costs? (YES / NO)</i>	
<i>- Conversion rate of the first day of the first month following the period covered by this Financial Statement? (YES/NO)</i>	

If necessary add another Form C.

<b>8- Contractor's Certificate</b>		
We certify that:		
- the costs declared above are directly related to the resources used to reach the objectives of the project ;		
- the receipts declared above are directly related to the resources used to reach the objectives of the project ;		
- the costs declared above fall within the definition of eligible costs specified in Articles II.19, II.20, II.21, II.22 and II.25 of the contract, and, if relevant, in Annex III and Article 9 (special clauses) of the contract ;		
- the receipts declared above fall within the definition of receipts specified in Article II.23 of the contract ;		
- the interest generated by the pre-financing declared above falls within the definition of Article II.27 of the contract ;		
- the necessary adjustments, especially to costs reported in previous Financial Statement(s) per Activity, have been incorporated in the above Statement ;		
- the above information declared is complete and true ;		
- there is full supporting documentation to justify the information hereby declared. It will be made available at the request of the Commission and in the event of an audit by the Commission and/or by the Court of Auditors and/or their authorised representatives.		
<b>Contractor's Stamp</b>	<b>Name of the Person responsible for the work</b>	<b>Name of the duly authorised Financial Officer</b>
	<b>Prof. Dr. Manfred Lindner</b>	<b>A. Baur</b>
	<b>Date</b>	<b>Date</b>
	<b>01/01/2006</b>	<b>01/01/2006</b>
	<b>Signature</b>	<b>Signature</b>

## 9 FZR

**Form C - Model of Financial Statement per Activity for Integrated Infrastructure Initiatives**  
*(to be completed by each contractor)*

Type of instrument	Integrated Infrastructure Initiatives	Type of Action (if necessary)	
Project Title (or Acronym)	CARE	Contract n°	RII3-CT-2003-506395
Contractors's legal name	Forschungszentrum Rossendorf e.V.		
Legal Type	Private public non-commercial		
Contact Person	Dr. Jochen Teichert	Telephone	0049 351 260 3445
Telecopy	0049 351 260 3690	E-mail	j.teichert@fz-rossendorf.de
Cost model used (AC/FC or FCF)/ (UF: User Fee)(*)	AC	Indirect costs (Real or Flat Rate of 20% of Direct costs, except subcontracting)	20%
Period from	01/01/2005	TO	31/12/2005

(\*) If UF is used under "other specific activities: transnational access/connectivity", please mention the two cost models used (eg. FC/UF or FCF/UF or AC/UF)

**1- Resources (Third party(ies))**

Are there any resources made available on the basis of a prior agreement with third parties identified in Annex I of the contract? (Yes / No) No

If Yes, please provide the following information

Third Party 1 (Y1)	Legal name	Cost model used
--------------------	------------	-----------------

If necessary add another Form C

**2- Declaration of eligible costs (in €)**

	Type of Activity													
	Research and Technological Development / Innovation		Demonstration		Management of the Consortium		Other Specific Activities: Coordination / Networking		Other Specific Activities: Transnational Access / Connectivity		Other Specific Activities		Total	
	(A)	(B)	(C)	(D)	(E)	(E)	(G) = (A)+(B)+(C)+(D)+(E)+(F)							
	Contractor	Third Party(ies)	Contractor	Third Party(ies)	Contractor	Third Party(ies)	Contractor	Third Party(ies)	Contractor	Third Party(ies)	Contractor	Third Party(ies)	Contractor	Third Party(ies)
Direct costs	119 501,00						4 957,70							124 458,70
Of which subcontracting														
Indirect costs	23 900,20						991,54							24 891,74
Adjustments to previous period(s)														
<b>Total costs</b>	143 401,20						5 949,24							149 350,44

**3- Declaration of receipts (in €)**

If you are a contractor using the additional cost model (AC), indicate only receipts covered by Article II.23.c of the contract.

If you are a contractor using a full cost model (FC/FCF), indicate receipts covered by Article II.23 of the contract.

	Type of Activity													
	Research and Technological Development / Innovation		Demonstration		Management of the Consortium		Other Specific Activities: Coordination / Networking		Other Specific Activities: Transnational Access / Connectivity		Other Specific Activities		Total	
	(A)	(B)	(C)	(D)	(E)	(E)	(G) = (A)+(B)+(C)+(D)+(E)+(F)							
	Contractor	Third Party(ies)	Contractor	Third Party(ies)	Contractor	Third Party(ies)	Contractor	Third Party(ies)	Contractor	Third Party(ies)	Contractor	Third Party(ies)	Contractor	Third Party(ies)
<b>Total receipts</b>													0	0

<b>4- Declaration of interest generated by the pre-financing (in €)</b>	
<i>To be completed only by the coordinator.</i>	
<i>Did the pre-financing (advance) you received by the Commission for this period earn interest? (Yes / No)</i>	
<i>If yes, please indicate the amount (in €)</i>	

<b>5- Request of FP6 Financial Contribution (in €)</b>	
<i>For this period, the FP6 Community financial contribution requested is equal to ( amount in €)</i>	149 350,44

<b>6- Audit certificates</b>	
<i>According to the contract, does this Financial Statement need an audit certificate (or several in case of Third party(ies)) delivered by independent auditor(s)? (Yes / No)</i>	Yes
<i>If Yes, does this(those) audit certificate(s) cover only this Financial Statement per Activity? (Yes / No)</i>	No
<i>If No, what are the periods covered by this(those) audit certificate(s) ?</i>	From - to 01.01.2004 - 31.12.2005
<i>What is the total cost of this(those) audit certificate(s) (in €) per independent auditor(s) ?</i>	

Audit certificate of the contractor (X)			
Legal name of the audit firm	ECOVIS Wirtschaftstreuhand GmbH	Cost of the certificate	
Audit certificate(s) of the third party(ies) (Ys) (if necessary)			
Y1 : Legal name of the audit firm		Cost of the certificate	
<i>If necessary add another Form C.</i>		Total (Z) = (X) + (Ys)	
<i>Reminders:</i>			
<i>The cost of an audit certificate is included in the costs declared under the activity "Management of the Consortium". The required audit certificate (s) is (are) attached to this Financial Statement</i>			

<b>7- Conversion rates</b>	
Costs incurred in currencies other than EURO shall be reported in EURO.	
Please mention the conversion rate used (only one choice is possible) – Please note that the same principle applies for receipts.	
Contractor	
- Conversion rate of the date of incurred actual costs? (YES / NO)	
- Conversion rate of the first day of the first month following the period covered by this Financial Statement? (YES/NO)	
Third Party(ies) (if necessary)	
Third Party 1 (Y1)	
- Conversion rate of the date of incurred actual costs? (YES / NO)	
- Conversion rate of the first day of the first month following the period covered by this Financial Statement? (YES/NO)	

If necessary add another Form C.

<b>8- Contractor's Certificate</b>		
We certify that:		
- the costs declared above are directly related to the resources used to reach the objectives of the project ;		
- the receipts declared above are directly related to the resources used to reach the objectives of the project ;		
- the costs declared above fall within the definition of eligible costs specified in Articles II.19, II.20, II.21, II.22 and II.25 of the contract, and, if relevant, in Annex III and Article 9 (special clauses) of the contract ;		
- the receipts declared above fall within the definition of receipts specified in Article II.23 of the contract ;		
- the interest generated by the pre-financing declared above falls within the definition of Article II.27 of the contract ;		
- the necessary adjustments, especially to costs reported in previous Financial Statement(s) per Activity, have been incorporated in the above Statement ;		
- the above information declared is complete and true ;		
- there is full supporting documentation to justify the information hereby declared. It will be made available at the request of the Commission and in the event of an audit by the Commission and/or by the Court of Auditors and/or their authorised representatives.		
Contractor's Stamp	Name of the Person responsible for the work	Name of the duly authorised Financial Officer
	Dr. Jochen Teichert	Peter Griepentrog
	Date	Date
	17/01/2006	17/01/2006
	Signature	Signature

## 10 INFN

**Form C - Model of Financial Statement per Activity for Integrated Infrastructure Initiatives**  
*(to be completed by each contractor)*

Type of instrument	Integrated Infrastructure Initiatives	Type of Action (if necessary)	
Project Title (or Acronym)	CARE	Contract n°	R1I3-CT-2003-506395
Contractors's legal name	Istituto Nazionale di Fisica Nucleare		
Legal Type	GOV		
Contact Person	Maria Teresa Ghirelli	Telephone	+39 6 94032237
Telecopy	+39 6 94032630	E-mail	ghirelli@inf.infn.it
Cost model used (AC/FC or FCF) (UF: User Fee)(*)	AC	Indirect costs (Real or Flat Rate of 20% of Direct costs, except subcontracting)	20%
Period from	01/01/2005	TO	31/12/2005

(\*) If UF is used under "other specific activities: transnational access/connectivity", please mention the two cost models used (eg. FC/UF or FCF/UF or AC/UF)

**1- Resources (Third party(ies))**

Are there any resources made available on the basis of a prior agreement with third parties identified in Annex I of the contract? (Yes / No)

NO

If Yes, please provide the following information

Third Party 1 (Y1)	Legal name		Cost model used	
--------------------	------------	--	-----------------	--

If necessary add another Form C

**2- Declaration of eligible costs (in €)**

	Type of Activity												Total (G) = (A)+(B)+(C)+ (D)+(E)+(F)		
	Research and Technological Development / Innovation (A)		Demonstration (B)		Management of the Consortium (C)		Other Specific Activities: Coordination / Networking (D)		Other Specific Activities: Transnational Access / Connectivity (E)		Other Specific Activities (E)				
	Contractor	Third Party(ies)	Contractor	Third Party(ies)	Contractor	Third Party(ies)	Contractor	Third Party(ies)	Contractor	Third Party(ies)	Contractor	Third Party(ies)	Contractor	Third Party(ies)	
Direct costs	398428,02						14713,89							413141,91	
Of which subcontracting															
Indirect costs	79685,60						2942,78							82628,38	
Adjustments to previous period(s)	-31959,92						14282,84							-17677,08	
<b>Total costs</b>	<b>446153,70</b>						<b>31939,51</b>							<b>478093,21</b>	

**3- Declaration of receipts (in €)**

If you are a contractor using the additional cost model (AC), indicate only receipts covered by Article II.23.c of the contract.

If you are a contractor using a full cost model (FC/FCF), indicate receipts covered by Article II.23 of the contract.

	Type of Activity												Total (G) = (A)+(B)+(C)+ (D)+(E)+(F)		
	Research and Technological Development / Innovation (A)		Demonstration (B)		Management of the Consortium (C)		Other Specific Activities: Coordination / Networking (D)		Other Specific Activities: Transnational Access / Connectivity (E)		Other Specific Activities (E)				
	Contractor	Third Party(ies)	Contractor	Third Party(ies)	Contractor	Third Party(ies)	Contractor	Third Party(ies)	Contractor	Third Party(ies)	Contractor	Third Party(ies)	Contractor	Third Party(ies)	
<b>Total receipts</b>															

<b>4- Declaration of interest generated by the pre-financing (in €)</b>	
<i>To be completed only by the coordinator.</i>	
<i>Did the pre-financing (advance) you received by the Commission for this period earn interest? (Yes / No)</i>	
<i>If yes, please indicate the amount (in €)</i>	

<b>5- Request of FP6 Financial Contribution (in €)</b>	
<i>For this period, the FP6 Community financial contribution requested is equal to ( amount in €)</i>	<b>478 093,21</b>

<b>6- Audit certificates</b>	
<i>According to the contract, does this Financial Statement need an audit certificate (or several in case of Third party(ies)) delivered by independent auditor(s)? (Yes / No)</i>	<b>yes</b>
<i>If Yes, does this(those) audit certificate(s) cover only this Financial Statement per Activity? (Yes / No)</i>	no
<i>If No, what are the periods covered by this(those) audit certificate(s) ?</i>	From - to <b>01/01/04 to 31/12/05</b>
<i>What is the total cost of this(those) audit certificate(s) (in €) per independent auditor(s) ?</i>	

<b>Audit certificate of the contractor (X)</b>			
<b>Legal name of the audit firm</b>	<b>Studio Cippitani &amp; Di Gioacchino</b>	<b>Cost of the certificate</b>	<b>3851,05 (will be included in the expenses for 2007)</b>
<b>Audit certificate(s) of the third party(ies) (Ys) (if necessary)</b>			
<b>Y1 : Legal name of the audit firm</b>		<b>Cost of the certificate</b>	
<b>If necessary add another Form C.</b>		<b>Total (Z) = (X) + (Ys)</b>	
<i>Reminders: The cost of an audit certificate is included in the costs declared under the activity "Management of the Consortium". The required audit certificate (s) is (are) attached to this Financial Statement</i>			

<b>7- Conversion rates</b>	
Costs incurred in currencies other than EURO shall be reported in EURO.	
Please mention the conversion rate used (only one choice is possible) – Please note that the same principle applies for receipts.	
<b>Contractor</b>	
- Conversion rate of the date of incurred actual costs? (YES / NO)	
- Conversion rate of the first day of the first month following the period covered by this Financial Statement? (YES/NO)	
<b>Third Party(ies) (if necessary)</b>	
<b>Third Party 1 (Y1)</b>	
- Conversion rate of the date of incurred actual costs? (YES / NO)	
- Conversion rate of the first day of the first month following the period covered by this Financial Statement? (YES/NO)	

If necessary add another Form C.

<b>8- Contractor's Certificate</b>		
We certify that:		
- the costs declared above are directly related to the resources used to reach the objectives of the project ;		
- the receipts declared above are directly related to the resources used to reach the objectives of the project ;		
- the costs declared above fall within the definition of eligible costs specified in Articles II.19, II.20, II.21, II.22 and II.25 of the contract, and, if relevant, in Annex III and Article 9 (special clauses) of the contract ;		
- the receipts declared above fall within the definition of receipts specified in Article II.23 of the contract ;		
- the interest generated by the pre-financing declared above falls within the definition of Article II.27 of the contract ;		
- the necessary adjustments, especially to costs reported in previous Financial Statement(s) per Activity, have been incorporated in the above Statement ;		
- the above information declared is complete and true ;		
- there is full supporting documentation to justify the information hereby declared. It will be made available at the request of the Commission and in the event of an audit by the Commission and/or by the Court of Auditors and/or their authorised representatives.		
<b>Contractor's Stamp</b>	<b>Name of the Person responsible for the work</b>	<b>Name of the duly authorised Financial Officer</b>
	<b>Susanna Guiducci</b>	<b>Maria Teresa Ghirelli</b>
	<b>Date</b>	<b>Date</b>
	<b>30/03/2006</b>	<b>30/03/2006</b>
	<b>Signature</b>	<b>Signature</b>

## 11 TEU

**Form C - Model of Financial Statement per Activity for Integrated Infrastructure Initiatives**  
*(to be completed by each contractor)*

Type of instrument	Integrated Infrastructure Initiatives	Type of Action (if necessary)	
Project Title (or Acronym)	CARE	Contract n°	RII3-CT-2003-506395
Contractors's legal name	UNIVERSITY OF TECHNOLOGY TWENTE		
Legal Type	GOVERNMENTAL		
Contact Person	A. Tigelaar	Telephone	+31 53 4893665
Telecopy	+31 53 4894841	E-mail	<a href="mailto:A.Tigelaar@utwente.nl">A.Tigelaar@utwente.nl</a>
Cost model used (AC/FC or FCF/UF: User Fee)(*))	FC	Indirect costs (Real or Flat Rate of 20% of Direct costs, except subcontracting)	
Period from	01-janv-05	TO	31-dec-2005

(\*)) If UF is used under "other specific activities: transnational access/connectivity", please mention the two cost models used (eg. FC/UF or FCF/UF or AC/UF)

**1- Resources (Third party(ies))**

Are there any resources made available on the basis of a prior agreement with third parties identified in Annex I of the contract? (Yes / No) **No**

If Yes, please provide the following information

Third Party 1 (Y1)	Legal name	Cost model used

If necessary add another Form C

**2- Declaration of eligible costs (in €)**

	Type of Activity													
	Research and Technological Development / Innovation (A)		Demonstration (B)		Management of the Consortium (C)		Other Specific Activities: Coordination / Networking (D)		Other Specific Activities: Transnational Access / Connectivity (E)		Other Specific Activities (E)		Total (G) = (A)+(B)+(C)+(D)+(E)+(F)	
	Contractor	Third Party(ies)	Contractor	Third Party(ies)	Contractor	Third Party(ies)	Contractor	Third Party(ies)	Contractor	Third Party(ies)	Contractor	Third Party(ies)	Contractor	Third Party(ies)
Direct costs	75967				814									76781
Of which subcontracting														
Indirect costs	69388													69388
Adjustments to previous period(s)														
<b>Total costs</b>	<b>145355</b>													<b>146169</b>

**3- Declaration of receipts (in €)**

If you are a contractor using the additional cost model (AC), indicate only receipts covered by Article II.23.c of the contract.

If you are a contractor using a full cost model (FC/FCF), indicate receipts covered by Article II.23 of the contract.

	Type of Activity													
	Research and Technological Development / Innovation (A)		Demonstration (B)		Management of the Consortium (C)		Other Specific Activities: Coordination / Networking (D)		Other Specific Activities: Transnational Access / Connectivity (E)		Other Specific Activities (E)		Total (G) = (A)+(B)+(C)+(D)+(E)+(F)	
	Contractor	Third Party(ies)	Contractor	Third Party(ies)	Contractor	Third Party(ies)	Contractor	Third Party(ies)	Contractor	Third Party(ies)	Contractor	Third Party(ies)	Contractor	Third Party(ies)
<b>Total receipts</b>														0



<b>4- Declaration of interest generated by the pre-financing (in €)</b>			
<i>To be completed only by the coordinator.</i>			
Did the pre-financing (advance) you received by the Commission for this period earn interest? (Yes / No)			
If yes, please indicate the amount (in €)			
<b>5- Request of FP6 Financial Contribution (in €)</b>			
For this period, the FP6 Community financial contribution requested is equal to ( amount in €)			<b>66478,00</b>
<b>6- Audit certificates</b>			
According to the contract, does this Financial Statement need an audit certificate (or several in case of Third party(ies)) delivered by independent auditor(s)? (Yes / No)			<b>yes</b>
If Yes, does this(those) audit certificate(s) cover only this Financial Statement per Activity? (Yes / No)			<b>no</b>
If No, what are the periods covered by this(those) audit certificate(s) ?		From - to	01-01-2004 to 31-12-2005
What is the total cost of this(those) audit certificate(s) (in €) per independent auditor(s) ? 814 euros			
<b>Audit certificate of the contractor (X)</b>			
Legal name of the audit firm	Ten Kate & Huizinga	Cost of the certificate	814 (for 2004), cost for 2005 not included in this form
<b>Audit certificate(s) of the third party(ies) (Ys) (if necessary)</b>			
Y1 : Legal name of the audit firm		Cost of the certificate	
Y2 : Legal name of the audit firm		Cost of the certificate	
Y3 : Legal name of the audit firm		Cost of the certificate	
Y4 : Legal name of the audit firm		Cost of the certificate	
If necessary add another Form C.		Total (Z) = (X) + (Ys)	
<i>Reminders:</i>			
<i>The cost of an audit certificate is included in the costs declared under the activity "Management of the Consortium". The required audit certificate (s) is (are) attached to this Financial Statement</i>			
<b>7- Conversion rates</b>			
Costs incurred in currencies other than EURO shall be reported in EURO.			
Please mention the conversion rate used (only one choice is possible) – Please note that the same principle applies for receipts.			
<b>Contractor</b>			
- Conversion rate of the date of incurred actual costs? (YES / NO)			<b>No</b>
- Conversion rate of the first day of the first month following the period covered by this Financial Statement? (YES/NO)			
<b>Third Party(ies) (if necessary)</b>			
<b>Third Party 1 (Y1)</b>			
- Conversion rate of the date of incurred actual costs? (YES / NO)			
- Conversion rate of the first day of the first month following the period covered by this Financial Statement? (YES/NO)			
If necessary add another Form C.			
<b>8- Contractor's Certificate</b>			
We certify that:			
- the costs declared above are directly related to the resources used to reach the objectives of the project ;			
- the receipts declared above are directly related to the resources used to reach the objectives of the project ;			
- the costs declared above fall within the definition of eligible costs specified in Articles II.19, II.20, II.21, II.22 and II.25 of the contract, and, if relevant, in Annex III and Article 9 (special clauses) of the contract ;			
- the receipts declared above fall within the definition of receipts specified in Article II.23 of the contract ;			
- the interest generated by the pre-financing declared above falls within the definition of Article II.27 of the contract ;			
- the necessary adjustments, especially to costs reported in previous Financial Statement(s) per Activity, have been incorporated in the above Statement ;			
- the above information declared is complete and true ;			
- there is full supporting documentation to justify the information hereby declared. It will be made available at the request of the Commission and in the event of an audit by the Commission and/or by the Court of Auditors and/or their authorised representatives.			
<b>Contractor's Stamp</b>	<b>Name of the Person responsible for the work</b>	<b>Name of the duly authorised Financial Officer</b>	
	<b>ir. A. den Ouden</b>	<b>A. Groenink</b>	
	<b>Date</b>	<b>Date</b>	
	<b>February 3rd. 2006</b>	<b>February 3rd. 2006</b>	
	<b>Signature</b>	<b>Signature</b>	

12 TUL

**Form C - Model of Financial Statement per Activity for Integrated Infrastructure Initiatives**  
*(to be completed by each contractor)*

Type of instrument	Integrated Infrastructure Initiatives	Type of Action (if necessary)	
Project Title (or Acronym)	CARE	Contract n°	RII3-CT-2003-506395
Contractors's legal name	TECHNICAL UNIVERSITY of LODZ, POLAND		
Legal Type	TECHNICAL UNIVERSITY		
Contact Person	Mariusz Grecki	Telephone	0-48-42-631-26-28
Telecopy	0-48-42-636-03-27	E-mail	grecki@dmcs.p.lodz.pl
Cost model used (AC/FC or FCF)/ (UF: User Fee)(*)	AC	Indirect costs (Real or Flat Rate of 20% of Direct costs, except subcontracting)	20%
Period from	1.01.2005	TO	31.12.2005

(\*) If UF is used under "other specific activities: transnational access/connectivity", please mention the two cost models used (eg. FC/UF or FCF/UF or AC/UF)

**1- Resources (Third party(ies))**

Are there any resources made available on the basis of a prior agreement with third parties identified in Annex I of the contract? (Yes / No)		No
If Yes, please provide the following information		
Third Party 1 (Y1)	Legal name	Cost model used
If necessary add another Form C		

**2- Declaration of eligible costs (in €)**

	Type of Activity													
	Research and Technological Development / Innovation		Demonstration		Management of the Consortium		Other Specific Activities: Coordination / Networking		Other Specific Activities: Transnational Access / Connectivity		Other Specific Activities		Total	
	(A)	(B)	(C)	(D)	(E)	(E)	(G) = (A)+(B)+(C)+(D)+(E)+(F)							
	Contractor	Third Party(ies)	Contractor	Third Party(ies)	Contractor	Third Party(ies)	Contractor	Third Party(ies)	Contractor	Third Party(ies)	Contractor	Third Party(ies)	Contractor	Third Party(ies)
Direct costs	130 286						2 032						132 317	
Of which subcontracting													0	
Indirect costs	26 057						406,3						26 464	
Adjustments to previous period(s)													0	
<b>Total costs</b>	<b>156 343</b>						<b>2 438</b>						<b>158 781</b>	

**3- Declaration of receipts (in €)**

If you are a contractor using the additional cost model (AC), indicate only receipts covered by Article II.23.c of the contract.  
 If you are a contractor using a full cost model (FC/FCF), indicate receipts covered by Article II.23 of the contract.

	Type of Activity													
	Research and Technological Development / Innovation		Demonstration		Management of the Consortium		Other Specific Activities: Coordination / Networking		Other Specific Activities: Transnational Access / Connectivity		Other Specific Activities		Total	
	(A)	(B)	(C)	(D)	(E)	(E)	(G) = (A)+(B)+(C)+(D)+(E)+(F)							
	Contractor	Third Party(ies)	Contractor	Third Party(ies)	Contractor	Third Party(ies)	Contractor	Third Party(ies)	Contractor	Third Party(ies)	Contractor	Third Party(ies)	Contractor	Third Party(ies)
<b>Total receipts</b>	0	0	0	0	0	0	0	0	0	0	0	0	0	0

<b>4- Declaration of interest generated by the pre-financing (in €)</b>	
<i>To be completed only by the coordinator.</i>	
Did the pre-financing (advance) you received by the Commission for this period earn interest? (Yes / No)	
If yes, please indicate the amount (in €)	

<b>5- Request of FP6 Financial Contribution (in €)</b>	
For this period, the FP6 Community financial contribution requested is equal to ( amount in €)	<b>158 781</b>

<b>6- Audit certificates</b>	
According to the contract, does this Financial Statement need an audit certificate (or several in case of Third party(ies)) delivered by independent auditor(s)? (Yes / No)	<b>Yes</b>
If Yes, does this(those) audit certificate(s) cover only this Financial Statement per Activity? (Yes / No)	<b>No</b>
If No, what are the periods covered by this(those) audit certificate(s) ?	From - to <b>01/01/2004 - 31/12/2005</b>
What is the total cost of this(those) audit certificate(s) (in €) per independent auditor(s) ?	<i>Euro 1250</i>

<b>Audit certificate of the contractor (X)</b>			
Legal name of the audit firm	AuditioSp.z o.o.Łódź, Kolarska 141,No.2187	Cost of the certificate	1250
Y1 : Legal name of the audit firm		Cost of the certificate	
<b>If necessary add another Form C.</b>		<b>Total (Z) = (X) + (Ys)</b>	1250
<i>Reminders:</i>			
<i>The cost of an audit certificate is included in the costs declared under the activity "Management of the Consortium". The required audit certificate (s) is (are) attached to this Financial Statement</i>			

<b>7- Conversion rates</b>	
Costs incurred in currencies other than EURO shall be reported in EURO.	
Please mention the conversion rate used (only one choice is possible) – Please note that the same principle applies for receipts.	
<b>Contractor</b>	
- Conversion rate of the date of incurred actual costs? (NO)	No
- Conversion rate of the first day of the first month following the period covered by this Financial Statement? (YES)	Yes
<b>Third Party(ies) (if necessary)</b>	
<b>Third Party 1 (Y1)</b>	
- Conversion rate of the date of incurred actual costs? (YES / NO)	
- Conversion rate of the first day of the first month following the period covered by this Financial Statement? (YES/NO)	

If necessary add another Form C.

<b>8- Contractor's Certificate</b>		
We certify that:		
- the costs declared above are directly related to the resources used to reach the objectives of the project ;		
- the receipts declared above are directly related to the resources used to reach the objectives of the project ;		
- the costs declared above fall within the definition of eligible costs specified in Articles II.19, II.20, II.21, II.22 and II.25 of the contract, and, if relevant, in Annex III and Article 9 (special clauses) of the contract ;		
- the receipts declared above fall within the definition of receipts specified in Article II.23 of the contract ;		
- the interest generated by the pre-financing declared above falls within the definition of Article II.27 of the contract ;		
- the necessary adjustments, especially to costs reported in previous Financial Statement(s) per Activity, have been incorporated in the above Statement ;		
- the above information declared is complete and true ;		
- there is full supporting documentation to justify the information hereby declared. It will be made available at the request of the Commission and in the event of an audit by the Commission and/or by the Court of Auditors and/or their authorised representatives.		
<b>Contractor's Stamp</b>	<b>Name of the Person responsible for the work</b>	<b>Name of the duly authorised Financial Officer</b>
	<b>prof. Andrzej Napieralski</b>	<b>Jadwiga Machnicka</b>
	<b>Date</b>	<b>Date</b>
	<b>20.01.2005</b>	<b>20.01.2005</b>
	<b>Signature</b>	<b>Signature</b>

## 13 IPJ

**Form C - Model of Financial Statement per Activity for Integrated Infrastructure Initiatives**  
*(to be completed by each contractor)*

Type of instrument	Integrated Infrastructure Initiatives	Type of Action (if necessary)	
Project Title (or Acronym)	CARE	Contract n°	RII3-CT-2003-506395
Contractors's legal name	The Andrzej Soltan Institute for Nuclear Studies		
Legal Type	gov		
Contact Person	Bogumila Rykaczewska	Telephone	48 22 7180583
Telecopy	48 22 7793481	E-mail	b.rykaczewska@ipi.gov.pl
Cost model used (AC/FC or FCF)/ (UF: User Fee)(*)	AC	Indirect costs (Real or Flat Rate of 20% of Direct costs, except subcontracting)	20%
Period from	January 1st 2005	TO	December 31 2005

(\*) If UF is used under "other specific activities: transnational access/connectivity", please mention the two cost models used (eg. FC/UF or FCF/UF or AC/UF)

**1- Resources (Third party(ies))**

Are there any resources made available on the basis of a prior agreement with third parties identified in Annex I of the contract? (Yes / No)

No

If Yes, please provide the following information

Third Party 1 (Y1)	Legal name	Cost model used
--------------------	------------	-----------------

If necessary add another Form C

**2- Declaration of eligible costs (in €)**

	Type of Activity													
	Research and Technological Development / Innovation (A)		Demonstration (B)		Management of the Consortium (C)		Other Specific Activities: Coordination / Networking (D)		Other Specific Activities: Transnational Access / Connectivity (E)		Other Specific Activities (E)		Total (G) = (A)+(B)+(C)+(D)+(E)+(F)	
	Contractor	Third Party(ies)	Contractor	Third Party(ies)	Contractor	Third Party(ies)	Contractor	Third Party(ies)	Contractor	Third Party(ies)	Contractor	Third Party(ies)	Contractor	Third Party(ies)
Direct costs	48 973,00				1 011,25		3 042,25							53 026,50
Of which subcontracting														
Indirect costs	9 794,60						608,40							10 403,00
Adjustments to previous period(s)	7 457,87						246,60							7 704,47
<b>Total costs</b>	<b>66 225,47</b>				<b>1 011,25</b>		<b>3 897,25</b>							<b>71 133,97</b>

**3- Declaration of receipts (in €)**

If you are a contractor using the additional cost model (AC), indicate only receipts covered by Article II.23.c of the contract.

If you are a contractor using a full cost model (FC/FCF), indicate receipts covered by Article II.23 of the contract.

	Type of Activity													
	Research and Technological Development / Innovation (A)		Demonstration (B)		Management of the Consortium (C)		Other Specific Activities: Coordination / Networking (D)		Other Specific Activities: Transnational Access / Connectivity (E)		Other Specific Activities (E)		Total (G) = (A)+(B)+(C)+(D)+(E)+(F)	
	Contractor	Third Party(ies)	Contractor	Third Party(ies)	Contractor	Third Party(ies)	Contractor	Third Party(ies)	Contractor	Third Party(ies)	Contractor	Third Party(ies)	Contractor	Third Party(ies)
<b>Total receipts</b>														0

<b>4- Declaration of interest generated by the pre-financing (in €)</b>	
<i>To be completed only by the coordinator.</i>	
<i>Did the pre-financing (advance) you received by the Commission for this period earn interest? (Yes / No)</i>	
<i>If yes, please indicate the amount (in €)</i>	

<b>5- Request of FP6 Financial Contribution (in €)</b>	
<i>For this period, the FP6 Community financial contribution requested is equal to ( amount in €)</i>	<b>71133,97</b>

<b>6- Audit certificates</b>	
<i>According to the contract, does this Financial Statement need an audit certificate (or several in case of Third party(ies)) delivered by independent auditor(s)? (Yes / No)</i>	<b>YES</b>
<i>If Yes, does this(those) audit certificate(s) cover only this Financial Statement per Activity? (Yes / No)</i>	<b>NO</b>
<i>If No, what are the periods covered by this(those) audit certificate(s) ?</i>	<b>From - to Jan 1, 2004 - Dec 31, 2005</b>
<i>What is the total cost of this(those) audit certificate(s) (in €) per independent auditor(s) ?</i>	<b>1011,25</b>

Audit certificate of the contractor (X)			
<b>Legal name of the audit firm</b>	<b>DORADCA Auditors Sp. z o.o.</b>	<b>Cost of the certificate</b>	<b>1011,25</b>
Audit certificate(s) of the third party(ies) (Ys) (if necessary)			
<b>Y1 : Legal name of the audit firm</b>		<b>Cost of the certificate</b>	
<b>If necessary add another Form C.</b>		<b>Total (Z) = (X) + (Ys)</b>	<b>1011,25</b>
<b>Reminders:</b>			
<i>The cost of an audit certificate is included in the costs declared under the activity "Management of the Consortium". The required audit certificate (s) is (are) attached to this Financial Statement</i>			

<b>7- Conversion rates</b>	
Costs incurred in currencies other than EURO shall be reported in EURO.	
Please mention the conversion rate used (only one choice is possible) – Please note that the same principle applies for receipts.	
Contractor	
<i>- Conversion rate of the date of incurred actual costs? (YES / NO)</i>	<b>NO</b>
<i>- Conversion rate of the first day of the first month following the period covered by this Financial Statement? (YES/NO)</i>	<b>YES</b>
Third Party(ies) (if necessary)	
Third Party 1 (Y1)	
<i>- Conversion rate of the date of incurred actual costs? (YES / NO)</i>	
<i>- Conversion rate of the first day of the first month following the period covered by this Financial Statement? (YES/NO)</i>	

If necessary add another Form C.

<b>8- Contractor's Certificate</b>		
We certify that:		
- the costs declared above are directly related to the resources used to reach the objectives of the project ;		
- the receipts declared above are directly related to the resources used to reach the objectives of the project ;		
- the costs declared above fall within the definition of eligible costs specified in Articles II.19, II.20, II.21, II.22 and II.25 of the contract, and, if relevant, in Annex III and Article 9 (special clauses) of the contract ;		
- the receipts declared above fall within the definition of receipts specified in Article II.23 of the contract ;		
- the interest generated by the pre-financing declared above falls within the definition of Article II.27 of the contract ;		
- the necessary adjustments, especially to costs reported in previous Financial Statement(s) per Activity, have been incorporated in the above Statement ;		
- the above information declared is complete and true ;		
- there is full supporting documentation to justify the information hereby declared. It will be made available at the request of the Commission and in the event of an audit by the Commission and/or by the Court of Auditors and/or their authorised representatives.		
Contractor's Stamp	Name of the Person responsible for the work	Name of the duly authorised Financial Officer
	<b>Prof. M. Sadowski</b>	<b>Anna Slapa</b>
	<b>Date</b>	<b>Date</b>
	<b>January 20 2006</b>	<b>January 20 2006</b>
	<b>Signature</b>	<b>Signature</b>

## 14 WUT-ISE

**Form C - Model of Financial Statement per Activity for Integrated Infrastructure Initiatives**  
*(to be completed by each contractor)*

Type of instrument	Integrated Infrastructure Initiatives	Type of Action (if necessary)	
Project Title (or Acronym)	CARE	Contract n°	R113-CT-2003-506395
Contractors's legal name	Politechnika Warszawska		
Legal Type	Governmental		
Contact Person	Ryszard Romaniuk	Telephone	+48 22 6607738
Telecopy	+48 22 8252300	E-mail	rrom@ise.pw.edu.pl
Cost model used (AC/FC or FCF)/ (UF: User Fee)(*)	AC	Indirect costs (Real or Flat Rate of 20% of Direct costs, except subcontracting)	Flat rate 20%
Period from	01/01/2005	TO	31/12/2005

(\*) If UF is used under "other specific activities: transnational access/connectivity", please mention the two cost models used (eg. FC/UF or FCF/UF or AC/UF)

**1- Resources (Third party(ies))**

Are there any resources made available on the basis of a prior agreement with third parties identified in Annex I of the contract? (Yes / No)

No

If Yes, please provide the following information

Third Party 1 (Y1)	Legal name		Cost model used	
--------------------	------------	--	-----------------	--

If necessary add another Form C

**2- Declaration of eligible costs (in €)**

	Type of Activity														Total (G) = (A)+(B)+(C)+ (D)+(E)+(F)	
	Research and Technological Development / Innovation (A)		Demonstration (B)		Management of the Consortium (C)		Other Specific Activities: Coordination / Networking (D)		Other Specific Activities: Transnational Access / Connectivity (E)		Other Specific Activities (E)					
	Contractor	Third Party(ies)	Contractor	Third Party(ies)	Contractor	Third Party(ies)	Contractor	Third Party(ies)	Contractor	Third Party(ies)	Contractor	Third Party(ies)	Contractor	Third Party(ies)		
Direct costs	119 342,14														119 342,14	
Of which subcontracting	0,00														0,00	
Indirect costs	23 868,43														23 868,43	
Adjustments to previous period(s)																
<b>Total costs</b>	<b>143 210,57</b>														<b>143 210,57</b>	

**3- Declaration of receipts (in €)**

If you are a contractor using the additional cost model (AC), indicate only receipts covered by Article II.23.c of the contract.

If you are a contractor using a full cost model (FC/FCF), indicate receipts covered by Article II.23 of the contract.

	Type of Activity														Total (G) = (A)+(B)+(C)+ (D)+(E)+(F)	
	Research and Technological Development / Innovation (A)		Demonstration (B)		Management of the Consortium (C)		Other Specific Activities: Coordination / Networking (D)		Other Specific Activities: Transnational Access / Connectivity (E)		Other Specific Activities (E)					
	Contractor	Third Party(ies)	Contractor	Third Party(ies)	Contractor	Third Party(ies)	Contractor	Third Party(ies)	Contractor	Third Party(ies)	Contractor	Third Party(ies)	Contractor	Third Party(ies)		
<b>Total receipts</b>																

<b>4- Declaration of interest generated by the pre-financing (in €)</b>	
<i>To be completed only by the coordinator.</i>	
<i>Did the pre-financing (advance) you received by the Commission for this period earn interest? (Yes / No)</i>	
<i>If yes, please indicate the amount (in €)</i>	

<b>5- Request of FP6 Financial Contribution (in €)</b>	
<i>For this period, the FP6 Community financial contribution requested is equal to ( amount in €)</i>	143 210,57

<b>6- Audit certificates</b>	
<i>According to the contract, does this Financial Statement need an audit certificate (or several in case of Third party(ies)) delivered by independent auditor(s)? (Yes / No)</i>	Yes
<i>If Yes, does this(those) audit certificate(s) cover only this Financial Statement per Activity? (Yes / No)</i>	Yes
<i>If No, what are the periods covered by this(those) audit certificate(s) ?</i>	From - to
<i>What is the total cost of this(those) audit certificate(s) (in €) per independent auditor(s) ?</i>	

<b>Audit certificate of the contractor (X)</b>			
<b>Legal name of the audit firm</b>	Horwath JBC Audit Sp. Z.o.o.	<b>Cost of the certificate</b>	1 188,65
<b>Audit certificate(s) of the third party(ies) (Ys) (if necessary)</b>			
<b>Y1 : Legal name of the audit firm</b>		<b>Cost of the certificate</b>	
<i>If necessary add another Form C.</i>		<b>Total (Z) = (X) + (Ys)</b>	
<i>Reminders:</i>			
<i>The cost of an audit certificate is included in the costs declared under the activity "Management of the Consortium". The required audit certificate (s) is (are) attached to this Financial Statement</i>			

<b>7- Conversion rates</b>	
Costs incurred in currencies other than EURO shall be reported in EURO.	
Please mention the conversion rate used (only one choice is possible) – Please note that the same principle applies for receipts.	
<b>Contractor</b>	
- Conversion rate of the date of incurred actual costs? (YES / NO)	NO
- Conversion rate of the first day of the first month following the period covered by this Financial Statement? (YES/NO)	YES
<b>Third Party(ies) (if necessary)</b>	
<b>Third Party 1 (Y1)</b>	
- Conversion rate of the date of incurred actual costs? (YES / NO)	
- Conversion rate of the first day of the first month following the period covered by this Financial Statement? (YES/NO)	

If necessary add another Form C.

<b>8- Contractor's Certificate</b>		
We certify that:		
- the costs declared above are directly related to the resources used to reach the objectives of the project ;		
- the receipts declared above are directly related to the resources used to reach the objectives of the project ;		
- the costs declared above fall within the definition of eligible costs specified in Articles II.19, II.20, II.21, II.22 and II.25 of the contract, and, if relevant, in Annex III and Article 9 (special clauses) of the contract ;		
- the receipts declared above fall within the definition of receipts specified in Article II.23 of the contract ;		
- the interest generated by the pre-financing declared above falls within the definition of Article II.27 of the contract ;		
- the necessary adjustments, especially to costs reported in previous Financial Statement(s) per Activity, have been incorporated in the above Statement ;		
- the above information declared is complete and true ;		
- there is full supporting documentation to justify the information hereby declared. It will be made available at the request of the Commission and in the event of an audit by the Commission and/or by the Court of Auditors and/or their authorised representatives.		
<b>Contractor's Stamp</b>	<b>Name of the Person responsible for the work</b>	<b>Name of the duly authorised Financial Officer</b>
	<b>Ryszard Romaniuk</b>	<b>Jadwiga Bajkowska</b>
	<b>Date</b>	<b>Date</b>
	<b>16.01.2006</b>	<b>16.01.2006</b>
	<b>Signature</b>	<b>Signature</b>



## 15 WUT

**Form C - Model of Financial Statement per Activity for Integrated Infrastructure Initiatives**  
*(to be completed by each contractor)*

Type of instrument	<b>Integrated Infrastructure Initiatives</b>	Type of Action (if necessary)	
Project Title (or Acronym)	CARE	Contract n°	RII3-CT-2003-506395
Contractors's legal name	<b>WROCLAW UNIVERSITY OF TECHNOLOGY</b>		
Legal Type			
Contact Person	<b>Maciej CHOROWSKI</b>	Telephone	<b>+48 71 320 23 25</b>
Telecopy	<b>+48 71 320 42 28</b>	E-mail	maciej.chorowski@pwr.wroc.pl
Cost model used (AC/FC or FCF)/ (UF: User Fee)(*)	<b>AC</b>	Indirect costs (Real or Flat Rate of 20% of Direct costs, except subcontracting)	<b>Flat Rate of 20% of Direct costs, except subcontracting</b>
Period from	<b>January 1st 2005</b>	To	<b>December 31 2005</b>

(\*) If UF is used under "other specific activities: transnational access/connectivity", please mention the two cost models used (eg. FC/UF or FCF/UF or AC/UF)

**1- Resources (Third party(ies))**

Are there any resources made available on the basis of a prior agreement with third parties identified in Annex I of the contract? (Yes / No)

**No**

If Yes, please provide the following information

Third Party 1 (Y1)	Legal name	Cost model used

If necessary add another Form C

**2- Declaration of eligible costs (in €)**

	Type of Activity												Total	
	Research and Technological Development / Innovation		Demonstration		Management of the Consortium		Other Specific Activities: Coordination / Networking		Other Specific Activities: Transnational Access / Connectivity		Other Specific Activities		(G) = (A)+(B)+(C)+(D)+(E)+(F)	
	(A)	(B)	(C)	(D)	(E)	(E)	(G)	(G)	(G)	(G)	(G)	(G)	(G)	
	Contractor	Third Party(ies)	Contractor	Third Party(ies)	Contractor	Third Party(ies)	Contractor	Third Party(ies)	Contractor	Third Party(ies)	Contractor	Third Party(ies)	Contractor	Third Party(ies)
Direct costs	15 913,40						677,66						16 591,06	
Of which subcontracting	0,00						0,00						0,00	
Indirect costs	3 182,68						135,53						3 318,21	
Adjustments to previous period(s)	0,00						0,00						0,00	
<b>Total costs</b>	<b>19 096,08</b>						<b>813,19</b>						<b>19 909,27</b>	

**3- Declaration of receipts (in €)**

If you are a contractor using the additional cost model (AC), indicate only receipts covered by Article II.23.c of the contract.

If you are a contractor using a full cost model (FC/FCF), indicate receipts covered by Article II.23 of the contract.

	Type of Activity												Total	
	Research and Technological Development / Innovation		Demonstration		Management of the Consortium		Other Specific Activities: Coordination / Networking		Other Specific Activities: Transnational Access / Connectivity		Other Specific Activities		(G) = (A)+(B)+(C)+(D)+(E)+(F)	
	(A)	(B)	(C)	(D)	(E)	(E)	(G)	(G)	(G)	(G)	(G)	(G)	(G)	
	Contractor	Third Party(ies)	Contractor	Third Party(ies)	Contractor	Third Party(ies)	Contractor	Third Party(ies)	Contractor	Third Party(ies)	Contractor	Third Party(ies)	Contractor	Third Party(ies)
<b>Total receipts</b>													0	

<b>4- Declaration of interest generated by the pre-financing (in €)</b>	
<i>To be completed only by the coordinator.</i>	
<i>Did the pre-financing (advance) you received by the Commission for this period earn interest? (Yes / No)</i>	
<i>If yes, please indicate the amount (in €)</i>	

<b>5- Request of FP6 Financial Contribution (in €)</b>	
<i>For this period, the FP6 Community financial contribution requested is equal to ( amount in €)</i>	<b>19 909,27</b>

<b>6- Audit certificates</b>	
<i>According to the contract, does this Financial Statement need an audit certificate (or several in case of Third party(ies)) delivered by independent auditor(s)? (Yes / No)</i>	<b>No</b>
<i>If Yes, does this(those) audit certificate(s) cover only this Financial Statement per Activity? (Yes / No)</i>	
<i>If No, what are the periods covered by this(those) audit certificate(s) ?</i>	From - to
<i>What is the total cost of this(those) audit certificate(s) (in €) per independent auditor(s) ?</i>	

<b>Audit certificate of the contractor (X)</b>			
<b>Legal name of the audit firm</b>		<b>Cost of the certificate</b>	
<b>Audit certificate(s) of the third party(ies) (Ys) (if necessary)</b>			
<b>Y1 : Legal name of the audit firm</b>		<b>Cost of the certificate</b>	
<i>If necessary add another Form C.</i>		<b>Total (Z) = (X) + (Ys)</b>	
<i>Reminders:</i>			
<i>The cost of an audit certificate is included in the costs declared under the activity "Management of the Consortium". The required audit certificate (s) is (are) attached to this Financial Statement</i>			

<b>7- Conversion rates</b>	
Costs incurred in currencies other than EURO shall be reported in EURO.	
Please mention the conversion rate used (only one choice is possible) – Please note that the same principle applies for receipts.	
<b>Contractor</b>	
- Conversion rate of the date of incurred actual costs? (YES / NO)	<b>No</b>
- Conversion rate of the first day of the first month following the period covered by this Financial Statement? (YES/NO)	<b>Yes</b>
<b>Third Party(ies) (if necessary)</b>	
<b>Third Party 1 (Y1)</b>	
- Conversion rate of the date of incurred actual costs? (YES / NO)	
- Conversion rate of the first day of the first month following the period covered by this Financial Statement? (YES/NO)	

If necessary add another Form C.

<b>8- Contractor's Certificate</b>		
We certify that:		
- the costs declared above are directly related to the resources used to reach the objectives of the project ;		
- the receipts declared above are directly related to the resources used to reach the objectives of the project ;		
- the costs declared above fall within the definition of eligible costs specified in Articles II.19, II.20, II.21, II.22 and II.25 of the contract, and, if relevant, in Annex III and Article 9 (special clauses) of the contract ;		
- the receipts declared above fall within the definition of receipts specified in Article II.23 of the contract ;		
- the interest generated by the pre-financing declared above falls within the definition of Article II.27 of the contract ;		
- the necessary adjustments, especially to costs reported in previous Financial Statement(s) per Activity, have been incorporated in the above Statement ;		
- the above information declared is complete and true ;		
- there is full supporting documentation to justify the information hereby declared. It will be made available at the request of the Commission and in the event of an audit by the Commission and/or by the Court of Auditors and/or their authorised representatives.		
<b>Contractor's Stamp</b>	<b>Name of the Person responsible for the work</b>	<b>Name of the duly authorised Financial Officer</b>
	<b>Maciej Chorowski</b>	<b>Alicja Maniak</b>
	<b>Date</b>	<b>Date</b>
	<b>27.01.2006</b>	<b>27.01.2006</b>
	<b>Signature</b>	<b>Signature</b>

## 16 CSIC

**Form C - Model of Financial Statement per Activity for Integrated Infrastructure Initiatives**  
*(to be completed by each contractor)*

Type of Instrument	Integrated Infrastructure Initiatives	Type of Action (if necessary)	
Project Title (or Acronym)	CARE	Contract n°	RII3-CT-2003-506395
Contractors's legal name	Consejo Superior de Investigaciones Científicas		
Legal Type			
Contact Person	Angeles Faus-Golfe	Telephone	34 963543545
Telecopy	34 963543488	E-mail	Angeles.Faus-Golfe@uv.es
Cost model used (AC/FC or FCF)/ (UF: User Fee)(*)	FC	Indirect costs (Real or Flat Rate of 20% of Direct costs, except subcontracting)	Real
Period from	1 January 2005	TO	31 December 2005

(\*) If UF is used under "other specific activities: transnational access/connectivity", please mention the two cost models used (eg. FC/UF or FCF/UF or AC/UF)

**1- Resources (Third party(ies))**

Are there any resources made available on the basis of a prior agreement with third parties identified in Annex I of the contract? (Yes / No) No

If Yes, please provide the following information

Third Party 1 (Y1)	Legal name	Cost model used

If necessary add another Form C

**2- Declaration of eligible costs (in €)**

	Type of Activity														Total (G) = (A)+(B)+(C)+ (D)+(E)+(F)
	Research and Technological Development / Innovation (A)		Demonstration (B)		Management of the Consortium (C)		Other Specific Activities: Coordination / Networking (D)		Other Specific Activities: Transnational Access / Connectivity (E)		Other Specific Activities (E)				
	Contractor	Third Party(ies)	Contractor	Third Party(ies)	Contractor	Third Party(ies)	Contractor	Third Party(ies)	Contractor	Third Party(ies)	Contractor	Third Party(ies)	Contractor	Third Party(ies)	
Direct costs					920,69		9337,93								10258,62
Of which subcontracting															
Indirect costs															
Adjustments to previous period(s)															
<b>Total costs</b>					920,69		9337,93								10258,62

**3- Declaration of receipts (in €)**

If you are a contractor using the additional cost model (AC), indicate only receipts covered by Article II.23.c of the contract.

If you are a contractor using a full cost model (FC/FCF), indicate receipts covered by Article II.23 of the contract.

	Type of Activity														Total (G) = (A)+(B)+(C)+ (D)+(E)+(F)
	Research and Technological Development / Innovation (A)		Demonstration (B)		Management of the Consortium (C)		Other Specific Activities: Coordination / Networking (D)		Other Specific Activities: Transnational Access / Connectivity (E)		Other Specific Activities (E)				
	Contractor	Third Party(ies)	Contractor	Third Party(ies)	Contractor	Third Party(ies)	Contractor	Third Party(ies)	Contractor	Third Party(ies)	Contractor	Third Party(ies)	Contractor	Third Party(ies)	
<b>Total receipts</b>															

<b>4- Declaration of interest generated by the pre-financing (in €)</b>	
<i>To be completed only by the coordinator.</i>	
<i>Did the pre-financing (advance) you received by the Commission for this period earn interest? (Yes / No)</i>	
<i>If yes, please indicate the amount (in €)</i>	

<b>5- Request of FP6 Financial Contribution (in €)</b>	
<i>For this period, the FP6 Community financial contribution requested is equal to ( amount in €)</i>	10258,62

<b>6- Audit certificates</b>	
<i>According to the contract, does this Financial Statement need an audit certificate (or several in case of Third party(ies)) delivered by independent auditor(s)? (Yes / No)</i>	No
<i>If Yes, does this(those) audit certificate(s) cover only this Financial Statement per Activity? (Yes / No)</i>	
<i>If No, what are the periods covered by this(those) audit certificate(s) ?</i>	From - to
<i>What is the total cost of this(those) audit certificate(s) (in €) per independent auditor(s) ?</i>	

<b>Audit certificate of the contractor (X)</b>			
<b>Legal name of the audit firm</b>	Audihispana S.A.	<b>Cost of the certificate</b>	920,69
<b>Audit certificate(s) of the third party(ies) (Ys) (if necessary)</b>			
<b>Y1 : Legal name of the audit firm</b>		<b>Cost of the certificate</b>	
<b>If necessary add another Form C.</b>		<b>Total (Z) = (X) + (Ys)</b>	920,69
<i>Reminders:</i>			
<i>The cost of an audit certificate is included in the costs declared under the activity "Management of the Consortium". The required audit certificate (s) is (are) attached to this Financial Statement</i>			

<b>7- Conversion rates</b>	
Costs incurred in currencies other than EURO shall be reported in EURO.	
Please mention the conversion rate used (only one choice is possible) – Please note that the same principle applies for receipts.	
<b>Contractor</b>	
<i>- Conversion rate of the date of incurred actual costs? (YES / NO)</i>	No
<i>- Conversion rate of the first day of the first month following the period covered by this Financial Statement? (YES/NO)</i>	
<b>Third Party(ies) (if necessary)</b>	
<b>Third Party 1 (Y1)</b>	
<i>- Conversion rate of the date of incurred actual costs? (YES / NO)</i>	
<i>- Conversion rate of the first day of the first month following the period covered by this Financial Statement? (YES/NO)</i>	

If necessary add another Form C.

<b>8- Contractor's Certificate</b>		
We certify that:		
- the costs declared above are directly related to the resources used to reach the objectives of the project ;		
- the receipts declared above are directly related to the resources used to reach the objectives of the project ;		
- the costs declared above fall within the definition of eligible costs specified in Articles II.19, II.20, II.21, II.22 and II.25 of the contract, and, if relevant, in Annex III and Article 9 (special clauses) of the contract ;		
- the receipts declared above fall within the definition of receipts specified in Article II.23 of the contract ;		
- the interest generated by the pre-financing declared above falls within the definition of Article II.27 of the contract ;		
- the necessary adjustments, especially to costs reported in previous Financial Statement(s) per Activity, have been incorporated in the above Statement ;		
- the above information declared is complete and true ;		
- there is full supporting documentation to justify the information hereby declared. It will be made available at the request of the Commission and in the event of an audit by the Commission and/or by the Court of Auditors and/or their authorised representatives.		
<b>Contractor's Stamp</b>	<b>Name of the Person responsible for the work</b>	<b>Name of the duly authorised Financial Officer</b>
	<b>Angeles Faus-Golfe</b>	<b>Maria del Mar Garcia Ferrer</b>
	<b>Date</b>	<b>Date</b>
	<b>18 January 2006</b>	<b>25 January 2006</b>
	<b>Signature</b>	<b>Signature</b>

## 17 CERN

## Form C - Model of Financial Statement per Activity for Integrated Infrastructure Initiatives

(to be completed by each contractor)

Type of instrument	Integrated Infrastructure Initiatives	Type of Action (if necessary)	
Project Title (or Acronym)	CARE	Contract n°	RII3-CT-2003-506395
Contractors's legal name	European Organisation for Nuclear Research		
Legal Type			
Contact Person	Gilbert Guignard	Telephone	+41-22-7675975
Telecopy	+41-22-7679590	E-mail	gilbert.guignard@cern.ch
Cost model used (AC/FC or FCF)/ (UF: User Fee)(*)	AC	Indirect costs (Real or Flat Rate of 20% of Direct costs, except subcontracting)	Flat Rate of 20%
Period from	01-janv-05	TO	31-déc-05

(\*) If UF is used under "other specific activities: transnational access/connectivity", please mention the two cost models used (eg. FC/UF or FCF/UF or AC/UF)

<b>1- Resources (Third party(ies))</b>			
Are there any resources made available on the basis of a prior agreement with third parties identified in Annex I of the contract? (Yes / No)			NO
If Yes, please provide the following information			
Third Party 1 (Y1)	Legal name	N/A	Cost model used
If necessary add another Form C			

<b>2- Declaration of eligible costs (in €)</b>														
	Type of Activity													
	Research and Technological Development / Innovation (A)		Demonstration (B)		Management of the Consortium (C)		Other Specific Activities: Coordination / Networking (D)		Other Specific Activities: Transnational Access / Connectivity (E)		Other Specific Activities (E)		Total (G) = (A)+(B)+(C)+(D)+(E)+(F)	
	Contractor	Third Party(ies)	Contractor	Third Party(ies)	Contractor	Third Party(ies)	Contractor	Third Party(ies)	Contractor	Third Party(ies)	Contractor	Third Party(ies)	Contractor	Third Party(ies)
Direct costs	906 564,55	N/A	N/A	N/A	N/A	N/A	69 939,08	N/A	N/A	N/A	N/A	N/A	976 503,63	N/A
Of which subcontracting	44 625,00	N/A	N/A	N/A	N/A	N/A	0,00	N/A	N/A	N/A	N/A	N/A	44 625,00	N/A
Indirect costs previous period(s)	172 387,91	N/A	N/A	N/A	N/A	N/A	13 987,82	N/A	N/A	N/A	N/A	N/A	186 375,73	N/A
	0,00	N/A	N/A	N/A	N/A	N/A	0,00	N/A	N/A	N/A	N/A	N/A	0,00	N/A
<b>Total costs</b>	<b>1 078 952,46</b>	N/A	N/A	N/A	N/A	N/A	<b>83 926,90</b>	N/A	N/A	N/A	N/A	N/A	<b>1 162 879,36</b>	N/A

<b>3- Declaration of receipts (in €)</b>													
If you are a contractor using the additional cost model (AC), indicate only receipts covered by Article II.23.c of the contract.													
If you are a contractor using a full cost model (FC/FCF), indicate receipts covered by Article II.23 of the contract.													

	Type of Activity													
	Research and Technological Development / Innovation (A)		Demonstration (B)		Management of the Consortium (C)		Other Specific Activities: Coordination / Networking (D)		Other Specific Activities: Transnational Access / Connectivity (E)		Other Specific Activities (E)		Total (G) = (A)+(B)+(C)+(D)+(E)+(F)	
	Contractor	Third Party(ies)	Contractor	Third Party(ies)	Contractor	Third Party(ies)	Contractor	Third Party(ies)	Contractor	Third Party(ies)	Contractor	Third Party(ies)	Contractor	Third Party(ies)
<b>Total receipts</b>													N/A	N/A

<b>4- Declaration of interest generated by the pre-financing (in €)</b>	
<i>To be completed only by the coordinator.</i>	
Did the pre-financing (advance) you received by the Commission for this period earn interest? (Yes / No)	<b>N/A</b>
If yes, please indicate the amount (in €)	

<b>5- Request of FP6 Financial Contribution (in €)</b>	
For this period, the FP6 Community financial contribution requested is equal to ( amount in €)	<b>1 162 879,36</b>

<b>6- Audit certificates</b>	
According to the contract, does this Financial Statement need an audit certificate (or several in case of Third party(ies)) delivered by independent auditor(s)? (Yes / No)	<b>YES</b>
If Yes, does this(those) audit certificate(s) cover only this Financial Statement per Activity? (Yes / No)	<b>No</b>
If No, what are the periods covered by this(those) audit certificate(s) ?	From - to <b>01/01/2004 to 31/12/2005</b>
What is the total cost of this(those) audit certificate(s) (in €) per independent auditor(s) ?	<b>NIL</b>

<b>Audit certificate of the contractor (X)</b>			
Legal name of the audit firm	<b>N/A 2004</b>	Cost of the certificate	<b>NIL</b>
<b>Audit certificate(s) of the third party(ies) (Ys) (if necessary)</b>			
Y1 : Legal name of the audit firm	<b>N/A</b>	Cost of the certificate	<b>N/A</b>
<b>If necessary add another Form C.</b>		Total (Z) = (X) + (Ys)	
<b>Reminders:</b>			
The cost of an audit certificate is included in the costs declared under the activity "Management of the Consortium". The required audit certificate (s) is (are) attached to this Financial Statement			

<b>7- Conversion rates</b>	
Costs incurred in currencies other than EURO shall be reported in EURO.	
Please mention the conversion rate used (only one choice is possible) – Please note that the same principle applies for receipts.	
<b>Euro 1 = CHF 1.5536</b>	
<b>Contractor</b>	
- Conversion rate of the date of incurred actual costs? (YES / NO)	<b>NO</b>
- Conversion rate of the first day of the first month following the period covered by this Financial Statement? (YES/NO)	<b>YES</b>
<b>Third Party(ies) (if necessary)</b>	
<b>Third Party 1 (Y1)</b>	
- Conversion rate of the date of incurred actual costs? (YES / NO)	<b>N/A</b>
- Conversion rate of the first day of the first month following the period covered by this Financial Statement? (YES/NO)	

If necessary add another Form C.

<b>8- Contractor's Certificate</b>		
We certify that:		
- the costs declared above are directly related to the resources used to reach the objectives of the project ;		
- the receipts declared above are directly related to the resources used to reach the objectives of the project ;		
- the costs declared above fall within the definition of eligible costs specified in Articles II.19, II.20, II.21, II.22 and II.25 of the contract, and, if relevant, in Annex III and Article 9 (special clauses) of the contract ;		
- the receipts declared above fall within the definition of receipts specified in Article II.23 of the contract ;		
- the interest generated by the pre-financing declared above falls within the definition of Article II.27 of the contract ;		
- the necessary adjustments, especially to costs reported in previous Financial Statement(s) per Activity, have been incorporated in the above Statement ;		
- the above information declared is complete and true ;		
- there is full supporting documentation to justify the information hereby declared. It will be made available at the request of the Commission and in the event of an audit by the Commission and/or by the Court of Auditors and/or their authorised representatives.		
<b>Contractor's Stamp</b>	<b>Name of the Person responsible for the work</b>	<b>Name of the duly authorised Financial Officer</b>
	<b>Gilbert Guignard</b>	<b>Thierry Lagrange</b>
	Date	Date
	<b>February 22, 2006</b>	<b>February 22, 2006</b>
	Signature	Signature

## 18 UNI-GE

**Form C - Model of Financial Statement per Activity for Integrated Infrastructure Initiatives**  
*(to be completed by each contractor)*

Type of Instrument	Integrated Infrastructure Initiatives	Type of Action (if necessary)	
Project Title (or Acronym)	CARE	Contract n°	RII3-CT-2003-506395
Contractors's legal name	University of Geneva		
Legal Type			
Contact Person	Alain Blondel	Telephone	00 41 22 379 6227
Telecopy	41223796992	E-mail	alain.blondel@cern.ch
Cost model used (AC/FC or FCF)/ (UF: User Fee)(*)	AC	Indirect costs (Real or Flat Rate of 20% of Direct costs, except subcontracting)	
Period from	01-janv-05	TO	31-déc-05

(\*) If UF is used under "other specific activities: transnational access/connectivity", please mention the two cost models used (eg. FC/UF or FCF/UF or AC/UF)

**1- Resources (Third party(ies))**

Are there any resources made available on the basis of a prior agreement with third parties identified in Annex I of the contract? (Yes / No)

If Yes, please provide the following information

Third Party 1 (Y1)	Legal name	Cost model used

If necessary add another Form C

**2- Declaration of eligible costs (in €)**

	Type of Activity													
	Research and Technological Development / Innovation (A)		Demonstration (B)		Management of the Consortium (C)		Other Specific Activities: Coordination / Networking (D)		Other Specific Activities: Transnational Access / Connectivity (E)		Other Specific Activities (E)		Total (G) = (A)+(B)+(C)+(D)+(E)+(F)	
	Contractor	Third Party(ies)	Contractor	Third Party(ies)	Contractor	Third Party(ies)	Contractor	Third Party(ies)	Contractor	Third Party(ies)	Contractor	Third Party(ies)	Contractor	Third Party(ies)
Direct costs							10 214,02 €							10 214,02 €
Of which subcontracting														
Indirect costs							409,95 €							409,95 €
Adjustments to previous period(s)														
<b>Total costs</b>							10 623,97 €							10 623,97 €

**3- Declaration of receipts (in €)**

If you are a contractor using the additional cost model (AC), indicate only receipts covered by Article II.23.c of the contract.

If you are a contractor using a full cost model (FC/FCF), indicate receipts covered by Article II.23 of the contract.

	Type of Activity													
	Research and Technological Development / Innovation (A)		Demonstration (B)		Management of the Consortium (C)		Other Specific Activities: Coordination / Networking (D)		Other Specific Activities: Transnational Access / Connectivity (E)		Other Specific Activities (E)		Total (G) = (A)+(B)+(C)+(D)+(E)+(F)	
	Contractor	Third Party(ies)	Contractor	Third Party(ies)	Contractor	Third Party(ies)	Contractor	Third Party(ies)	Contractor	Third Party(ies)	Contractor	Third Party(ies)	Contractor	Third Party(ies)
<b>Total receipts</b>														



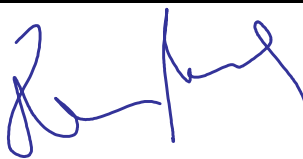
<b>4- Declaration of interest generated by the pre-financing (in €)</b>	
<i>To be completed only by the coordinator.</i>	
Did the pre-financing (advance) you received by the Commission for this period earn interest? (Yes / No)	
If yes, please indicate the amount (in €)	

<b>5- Request of FP6 Financial Contribution (in €)</b>	
For this period, the FP6 Community financial contribution requested is equal to ( amount in €)	0 €

<b>6- Audit certificates</b>	
According to the contract, does this Financial Statement need an audit certificate (or several in case of Third party(ies)) delivered by independent auditor(s)? (Yes / No)	no
If Yes, does this(those) audit certificate(s) cover only this Financial Statement per Activity? (Yes / No)	
If No, what are the periods covered by this(those) audit certificate(s) ?	From - to
What is the total cost of this(those) audit certificate(s) (in €) per independent auditor(s) ?	

<b>Audit certificate of the contractor (X)</b>			
Legal name of the audit firm		Cost of the certificate	
<b>Audit certificate(s) of the third party(ies) (Ys) (if necessary)</b>			
Y1 : Legal name of the audit firm		Cost of the certificate	
<b>If necessary add another Form C.</b>		<b>Total (Z) = (X) + (Ys)</b>	
<i>Reminders:</i>			
<i>The cost of an audit certificate is included in the costs declared under the activity "Management of the Consortium". The required audit certificate (s) is (are) attached to this Financial Statement</i>			

<b>7- Conversion rates</b>	
Costs incurred in currencies other than EURO shall be reported in EURO.	
Please mention the conversion rate used (only one choice is possible) – Please note that the same principle applies for receipts. 1€ = 1.5536 CHF	
<b>Contractor</b>	
- Conversion rate of the date of incurred actual costs? (YES / NO)	NO
- Conversion rate of the first day of the first month following the period covered by this Financial Statement? (YES/NO)	YES
<b>Third Party(ies) (if necessary)</b>	
<b>Third Party 1 (Y1)</b>	
- Conversion rate of the date of incurred actual costs? (YES / NO)	
- Conversion rate of the first day of the first month following the period covered by this Financial Statement? (YES/NO)	
If necessary add another Form C.	

<b>8- Contractor's Certificate</b>		
We certify that:		
- the costs declared above are directly related to the resources used to reach the objectives of the project ;		
- the receipts declared above are directly related to the resources used to reach the objectives of the project ;		
- the costs declared above fall within the definition of eligible costs specified in Articles II.19, II.20, II.21, II.22 and II.25 of the contract, and, if relevant, in Annex III and Article 9 (special clauses) of the contract ;		
- the receipts declared above fall within the definition of receipts specified in Article II.23 of the contract ;		
- the interest generated by the pre-financing declared above falls within the definition of Article II.27 of the contract ;		
- the necessary adjustments, especially to costs reported in previous Financial Statement(s) per Activity, have been incorporated in the above Statement ;		
- the above information declared is complete and true ;		
- there is full supporting documentation to justify the information hereby declared. It will be made available at the request of the Commission and in the event of an audit by the Commission and/or by the Court of Auditors and/or their authorised representatives.		
<b>Contractor's Stamp</b>	<b>Name of the Person responsible for the work</b>	<b>Name of the duly authorised Financial Officer</b>
	<b>Alain Blondel</b>	Beda Manzano di Blasi
	<b>Date</b>	<b>Date</b>
	<b>21-févr-06</b>	<b>21-févr-06</b>
	<b>Signature</b>	<b>Signature</b>
		

## 19 PSI

**Form C - Model of Financial Statement per Activity for Integrated Infrastructure Initiatives**  
*(to be completed by each contractor)*

Type of instrument	Integrated Infrastructure Initiatives	Type of Action (if necessary)	
Project Title (or Acronym)	CARE	Contract n°	RII3-CT-2003-506395
Contractors's legal name	Paul Scherrer Institute (PSI)		
Legal Type			
Contact Person	Volker Schlott	Telephone	00 41 56 310 4237
Telecopy	0041 56 310 4528	E-mail	volker.schlott@psi.ch
Cost model used (AC/FC or FCF/UF: User Fee)(*)	FC	Indirect costs (Real or Flat Rate of 20% of Direct costs, except subcontracting)	Real
Period from	01-janv-05	TO	31-déc-05

(\*) If UF is used under "other specific activities: transnational access/connectivity", please mention the two cost models used (eg. FC/UF or FCF/UF or AC/UF)

**1- Resources (Third party(ies))**

Are there any resources made available on the basis of a prior agreement with third parties identified in Annex I of the contract? (Yes / No) **No**

If Yes, please provide the following information

Third Party 1 (Y1)	Legal name	Cost model used

If necessary add another Form C

**2- Declaration of eligible costs (in €)**

	Type of Activity													
	Research and Technological Development / Innovation (A)		Demonstration (B)		Management of the Consortium (C)		Other Specific Activities: Coordination / Networking (D)		Other Specific Activities: Transnational Access / Connectivity (E)		Other Specific Activities (E)		Total (G) = (A)+(B)+(C)+(D)+(E)+(F)	
	Contractor	Third Party(ies)	Contractor	Third Party(ies)	Contractor	Third Party(ies)	Contractor	Third Party(ies)	Contractor	Third Party(ies)	Contractor	Third Party(ies)	Contractor	Third Party(ies)
Direct costs	85 247,93						1 248,09							86 496,02
Of which subcontracting														
Indirect costs	4 639,08													4 639,08
Adjustments to previous period(s)														
<b>Total costs</b>	<b>89 887,01</b>						<b>1 248,09</b>							<b>91 135,10</b>

**3- Declaration of receipts (in €)**

If you are a contractor using the additional cost model (AC), indicate only receipts covered by Article II.23.c of the contract.

If you are a contractor using a full cost model (FC/FCF), indicate receipts covered by Article II.23 of the contract.

	Type of Activity													
	Research and Technological Development / Innovation (A)		Demonstration (B)		Management of the Consortium (C)		Other Specific Activities: Coordination / Networking (D)		Other Specific Activities: Transnational Access / Connectivity (E)		Other Specific Activities (E)		Total (G) = (A)+(B)+(C)+(D)+(E)+(F)	
	Contractor	Third Party(ies)	Contractor	Third Party(ies)	Contractor	Third Party(ies)	Contractor	Third Party(ies)	Contractor	Third Party(ies)	Contractor	Third Party(ies)	Contractor	Third Party(ies)
<b>Total receipts</b>														<b>0</b>

<b>4- Declaration of interest generated by the pre-financing (in €)</b>	
<i>To be completed only by the coordinator.</i>	
<i>Did the pre-financing (advance) you received by the Commission for this period earn interest? (Yes / No)</i>	
<i>If yes, please indicate the amount (in €)</i>	

<b>5- Request of FP6 Financial Contribution (in €)</b>	
<i>For this period, the FP6 Community financial contribution requested is equal to ( amount in €)</i>	0 €

<b>6- Audit certificates</b>	
<i>According to the contract, does this Financial Statement need an audit certificate (or several in case of Third party(ies)) delivered by independent auditor(s)? (Yes / No)</i>	<b>No</b>
<i>If Yes, does this(those) audit certificate(s) cover only this Financial Statement per Activity? (Yes / No)</i>	
<i>If No, what are the periods covered by this(those) audit certificate(s) ?</i>	From - to
<i>What is the total cost of this(those) audit certificate(s) (in €) per independent auditor(s) ?</i>	

Audit certificate of the contractor (X)			
Legal name of the audit firm		Cost of the certificate	
Audit certificate(s) of the third party(ies) (Ys) (if necessary)			
Y1 : Legal name of the audit firm		Cost of the certificate	
<i>If necessary add another Form C.</i>		Total (Z) = (X) + (Ys)	
<i>Reminders:</i>			
<i>The cost of an audit certificate is included in the costs declared under the activity "Management of the Consortium". The required audit certificate (s) is (are) attached to this Financial Statement</i>			

<b>7- Conversion rates</b>	
Costs incurred in currencies other than EURO shall be reported in EURO.	
Please mention the conversion rate used (only one choice is possible) – Please note that the same principle applies for receipts.	
Contractor	
- Conversion rate of the date of incurred actual costs? (YES / NO)	<b>No</b>
- Conversion rate of the first day of the first month following the period covered by this Financial Statement? (YES/NO)	<b>Yes</b>
Third Party(ies) (if necessary)	
Third Party 1 (Y1)	
- Conversion rate of the date of incurred actual costs? (YES / NO)	
- Conversion rate of the first day of the first month following the period covered by this Financial Statement? (YES/NO)	

If necessary add another Form C.

<b>8- Contractor's Certificate</b>		
We certify that:		
- the costs declared above are directly related to the resources used to reach the objectives of the project ;		
- the receipts declared above are directly related to the resources used to reach the objectives of the project ;		
- the costs declared above fall within the definition of eligible costs specified in Articles II.19, II.20, II.21, II.22 and II.25 of the contract, and, if relevant, in Annex III and Article 9 (special clauses) of the contract ;		
- the receipts declared above fall within the definition of receipts specified in Article II.23 of the contract ;		
- the interest generated by the pre-financing declared above falls within the definition of Article II.27 of the contract ;		
- the necessary adjustments, especially to costs reported in previous Financial Statement(s) per Activity, have been incorporated in the above Statement ;		
- the above information declared is complete and true ;		
- there is full supporting documentation to justify the information hereby declared. It will be made available at the request of the Commission and in the event of an audit by the Commission and/or by the Court of Auditors and/or their authorised representatives.		
Contractor's Stamp	Name of the Person responsible for the work	Name of the duly authorised Financial Officer
	<b>Volker Schlott</b>	<b>Angela Vatter</b>
	Date	Date
	<b>15-févr-06</b>	<b>15-févr-06</b>
	Signature	Signature

**20 CCLRC**

This document has been approved by the Commission on 23 October 2003- Decision C(2003)3834 dated 23.10.03

**Form C - Model of Financial Statement per Activity for Integrated Initiatives for Infrastructures**  
(to be completed by each contractor)

Type of instrument	Integrated Initiative for Infrastructures	Type of Action (if necessary)	N.A.
Project title (or Acronym)	CARE	Contract n°	RII3-CT-2003-506395
Contractor's Legal Name	Council for the Central Laboratory of the Research Councils		
Legal Type			
Contact Person	Caroline Gore	Telephone	01235 445697
Telecopy	01235 445584	E-mail	c.m.gore@rl.ac.uk
Cost Model used (AC/FC or FCF) / (UF: User Fee) (*)	FC	Indirect costs (Real or Flat rate of 20% of Direct costs, except subcontracting)	Real
Period from	01-janv-05 To		31-déc-05

(\*) If UF is used under "other specific activities: transnational access/connectivity", please mention the two cost models used (e.g.: FC / UF or FCF / UF or AC/UF)

**1 - Resources (Third party(ies))**

Are there any resources made available on the basis of a prior agreement with third parties identified in Annex I of the contract (Yes/No)

If yes, please provide the following information

Third Party 1 (Y1)	Legal Name	Cost model used
--------------------	------------	-----------------

If necessary add another Form C

**2 - Declaration of eligible costs (in €)**

	Type of Activity												Total (G) = (A)+(B)+(C)+(D)+(E)+(F)			
	Research and Technological Development / Innovation (A)		Demonstration (B)		Management of the Consortium (C)		Other Specific Activities: Coordination / Networking (D)		Other Specific Activities: Transnational Access / Connectivity (E)		Other Specific Activities (F)					
	Contractor	Third Party(ies)	Contractor	Third Party(ies)	Contractor	Third Party(ies)	Contractor	Third Party(ies)	Contractor	Third Party(ies)	Contractor	Third Party(ies)	Contractor	Third Party(ies)		
Direct Costs	411 621,64						18 409,75								430 031,39	
Of which subcontracting																
Indirect costs	358 171,25														358 171,25	
Adjustments to previous period(s)	32 549,73														32 549,73	
Total costs	802 342,62					0,00	18 409,75								820 752,37	

**3- Declaration of receipts (in €)**

If you are a contractor using the additional cost model (AC), indicate only receipts covered by Article II.23.c of the contract.

If you are a contractor using a full cost model (FC/FCF), indicate receipts covered by Article II.23 of the contract.

	Type of Activity												Total (G) = (A)+(B)+(C)+(D)+(E)+(F)			
	Research and Technological Development / Innovation (A')		Demonstration (B')		Management of the Consortium (C')		Other Specific Activities: Coordination / Networking (D')		Other Specific Activities: Transnational Access / Connectivity (E)		Other Specific Activities (F)					
	Contractor	Third Party(ies)	Contractor	Third Party(ies)	Contractor	Third Party(ies)	Contractor	Third Party(ies)	Contractor	Third Party(ies)	Contractor	Third Party(ies)	Contractor	Third Party(ies)		
Total Receipts																

B. MANAGEMENT REPORT (FINANCIAL INFORMATION)

<b>4- Declaration of interest generated by the pre-financing (in €)</b>	
<i>To be completed only by the coordinator.</i>	
Did the pre-financing (advance) you received by the Commission for this period earn interest? (Yes / No)	
If yes, please indicate the amount (in €)	

<b>5- Request of FP6 Financial contribution (in €)</b>	
For this period, the FP6 Community financial contribution requested is equal to (amount in €)	<b>€ 233 946,67</b>

<b>6- Audit certificates</b>	
According to the contract, does this Financial Statement need an audit certificate (or several in case of Third party(ies)) delivered by independent auditor(s)? (Yes / No)	<b>Yes</b>
If Yes, does this(those) audit certificate(s) cover only this Financial Statement per Activity? (Yes / No)	<b>Yes</b>
If No, what are the periods covered by this(those) audit certificate(s) ?	<b>From - To</b>
What is the total cost of this(those) audit certificate(s) (in €) per independent auditor(s)	<b>€ 500 Estimate</b>
<b>Audit certificate of the contractor (X)</b>	
Legal name of the audit firm	Cost of the certificate
<b>Audit certificate(s) of the third party(ies) (Ys) (if necessary)</b>	
<b>Y1 : Legal name of the audit firm</b>	<b>Research Councils Internal Audit Service</b>
<b>Y2 : Legal name of the audit firm</b>	Cost of the certificate
<b>Y3 : Legal name of the audit firm</b>	Cost of the certificate
<b>Y4 : Legal name of the audit firm</b>	Cost of the certificate
<i>If necessary add another Form C.</i>	<b>Total (Z) = (X) + (Ys)</b>
<b>Reminders:</b>	
<i>The cost of an audit certificate is included in the costs declared under the activity "Management of the Consortium".</i>	
<i>The required audit certificate(s) is(are) attached to this Financial Statement.</i>	

<b>7- Conversion rates</b>	
Costs incurred in currencies other than EURO shall be reported in EURO.	
Please mention the conversion rate used (only one choice is possible) – Please note that the same principle applies for receipts.	

<b>Contractor</b>	
- Conversion rate of the date of incurred actual costs? (YES / NO)	<b>NO</b>
- Conversion rate of the first day of the first month following the period covered by this Financial Statement? (YES/NO)	<b>Yes E/R 0.6865</b>
<b>Third Party(ies) (if necessary)</b>	
<b>Third Party 1 (Y1)</b>	
- Conversion rate of the date of incurred actual costs? (YES / NO)	
- Conversion rate of the first day of the first month following the period covered by this Financial Statement? (YES/NO)	
<i>If necessary add another Form C.</i>	

<b>8- Contractor's Certificate</b>		
We certify that:		
- the costs declared above are directly related to the resources used to reach the objectives of the project ;		
- the receipts declared above are directly related to the resources used to reach the objectives of the project ;		
- the costs declared above fall within the definition of eligible costs specified in Articles II.19, II.20, II.21, II.22 and II.25 of the contract, and, if relevant, in Annex III and Article 9 (special clauses) of the contract ;		
- the receipts declared above fall within the definition of receipts specified in Article II.23 of the contract ;		
- the interest generated by the pre-financing declared above falls within the definition of Article II.27 of the contract ;		
- the necessary adjustments, especially to costs reported in previous Financial Statement(s) per Activity, have been incorporated in the above Statement ;		
- the above information declared is complete and true ;		
- there is full supporting documentation to justify the information hereby declared. It will be made available at the request of the Commission and in the event of an audit by the Commission and/or by the Court of Auditors and/or their authorised representatives.		
<b>Contractor's Stamp</b>	<b>Name of the Person responsible for the work</b>	<b>Name of the duly authorised Financial Officer</b>
	<b>Dr Rob Edgecock</b>	<b>Caroline Gore</b>
	<b>Date</b>	<b>Date</b>
	<b>02/02/2006</b>	<b>02/02/2006</b>
	<b>Signature</b>	<b>Signature</b>

## 21 ICL

**Form C - Model of Financial Statement per Activity for Integrated Initiatives for Infrastructures**  
*(to be completed by each contractor)*

Type of instrument	Integrated Initiatives for Infrastructures	Type of Action (if necessary)	N.A.
Project Title (or Acronym)	CARE	Contract n°	RII3-CT-2003-506395
Contractor's Legal Name	Imperial College of Science, Technology and Medicine		
Legal Type	PNP		
Contact Person	Brooke Alasya	Telephone	+44 (0)207 5941181
Telecopy	+44 (0)207 5941515	E-mail	b.alasya@imperial.ac.uk
Cost model used (AC/FC or FCF) / (UF: User Fee) (*)	AC	Indirect costs (Real or Flat Rate of 20% of Direct costs, except subcontracting)	Flat Rate of 20% of Direct Costs, except subcontracting
Period from	01 January 2005	To	31 December 2005

(\*) If UF is used under "other specific activities: transnational access", please mention the two costs models used (eg: FC/UF or FCF/UF or AC/UF)

**1 - Resources (Third party(ies))**

Are there any resources made available on the basis of a prior agreement with third parties identified in Annex I of the contract? (Yes / No)	No
If Yes, please provide the following information	

Third party 1 (Y1)	Legal Name		Cost model used	
If necessary add another Form C.				

**2 - Declaration of eligible costs (in €)**

	Type of Activity												Total (G) = (A)+(B)+(C)+(D)+(E)+(F)		
	Research and Technological Development / Innovation (A)		Demonstration (B)		Management of the Consortium (C)		Other Specific Activities: Coordination / Networking (D)		Other Specific Activities: Transnational Access /Connectivity (E)		Other Specific Activities (F)				
	Contractor	Third Party(ies)	Contractor	Third Party(ies)	Contractor	Third Party(ies)	Contractor	Third Party(ies)	Contractor	Third Party(ies)	Contractor	Third Party(ies)	Contractor	Third Party(ies)	
Direct costs					726,43		26 258,36							26 984,79	0,00
Of which subcontracting														0,00	0,00
Indirect costs							5 251,67							5 251,67	0,00
Adjustments to previous period(s)														0,00	0,00
<b>Total costs</b>	0,00	0,00	0,00	0,00	726,43	0,00	31 510,03	0,00	0,00	0,00	0,00	0,00	0,00	32 236,46	0,00

**3 - Declaration of receipts (in €)**

If you are a contractor using the additional cost model (AC), indicate only receipts covered by Article II.23.c of the contract.

If you are a contractor using a full cost model (FC/FCF), indicate receipts covered by Article II.23 of the contract.

	Type of Activity												Total (G) = (A)+(B)+(C)+(D)+(E)+(F)		
	Research and Technological Development / Innovation (A')		Demonstration (B')		Management of the Consortium (C)		Other Specific Activities: Coordination / Networking (D)		Other Specific Activities: Transnational Access /Connectivity (E)		Other Specific Activities (F)				
	Contractor	Third Party(ies)	Contractor	Third Party(ies)	Contractor	Third Party(ies)	Contractor	Third Party(ies)	Contractor	Third Party(ies)	Contractor	Third Party(ies)	Contractor	Third Party(ies)	
<b>Total receipts</b>														0,00	0,00

B. MANAGEMENT REPORT (FINANCIAL INFORMATION)

<b>4 - Declaration of interest generated by the pre-financing (in €)</b>	
To be completed only by the coordinator.	
Did the pre-financing (advance) you received by the Commission for this period earn interest (Yes / No)	
If yes, please indicate the amount (in €)	
<b>5 - Request of FP6 Financial contribution (in €)</b>	
For this period, the FP6 Community financial contribution requested is equal to (amount in €).	
32 236,46	
<b>6 - Audit certificates</b>	
According to the contract, does this Financial Statement need an audit certificate (or several in case of Third party(ies)) delivered by independent auditor(s)? (Yes / No)	
Yes	
If Yes, does this(those) audit certificate(s) cover only this Financial Statement per Activity? (Yes / No)	
Yes	
If No, what are the periods covered by this(those) audit certificate(s)?	
From - To	
What is the total cost of this(those) audit certificate(s) (in €) per independent auditor(s)?	
<b>Audit certificate of the contractor (X)</b>	
Legal name of the audit firm	Imperial College London
Cost of the certificate	285,01
<b>Audit certificate(s) of the third party(ies) (Ys) (if necessary)</b>	
Y1 : Legal name of the audit firm	
Cost of the certificate	
If necessary, add another Form C.	Total (Z) = (X) + (Ys) 285,01
Reminders:	
The cost of an audit certificate is included in the costs declared under the activity "Management of the Consortium".	
The required audit certificate is(are) attached to this Financial Statement.	
<b>7 - Conversion rates</b>	
Costs incurred in currencies other than EURO shall be reported in EURO.	
Please mention the conversion rate used (only one choice is possible) - Please note that the same principle applies for receipts.	
<b>Contractor</b>	
- Conversion rate of the date of incurred actual costs? (YES / NO)	no
- Conversion rate of the first day of the first month following the period covered by this Financial Statement? (YES/NO)	Yes
<b>Third party(ies) (if necessary)</b>	
<b>Third party 1 (Y1)</b>	
- Conversion rate of the date of incurred actual costs? (YES / NO)	
- Conversion rate of the first day of the first month following the period covered by this Financial Statement? (YES/NO)	
If necessary add another form C.	
<b>8 - Contractor's Certificate</b>	
We certify that:	
<ul style="list-style-type: none"> <li>- the costs declared above are directly related to the resources used to reach the objectives of the project ;</li> <li>- the receipts declared above are directly related to the resources used to reach the objectives of the project ;</li> <li>- the costs declared above fall within the definition of eligible costs specified in Articles II.19, II.20, II.21, II.22 and II.25 of the contract, and, if relevant, in Annex III and Article 9 (special clauses) of the contract ;</li> <li>- the receipts declared above fall within the definition of receipts specified in Article II.23 of the contract ;</li> <li>- the interest generated by the pre-financing declared above falls within the definition of Article II.27 of the contract ;</li> <li>- the necessary adjustments, especially to costs reported in previous Financial Statement(s) per Activity, have been incorporated in the above Statement ;</li> <li>- the above information declared is complete and true ;</li> <li>- there is full supporting documentation to justify the information hereby declared. It will be made available at the request of the Commission and in the event of an audit by the Commission and/or by the Court of Auditors and/or their authorised representatives.</li> </ul>	
<b>Contractor's Stamp</b>	<b>Name of the Person responsible for the work</b>
	Professor Ken Long
	Date
	20/01/2005
	Signature
	<b>Name of the duly authorised Financial Officer</b>
	Brooke Alasya
	Date
	20/01/2006
	Signature



## 22 UMA

**Form C - Model of Financial Statement per Activity for Integrated Infrastructure Initiatives**  
(to be completed by each contractor)

Type of instrument	<b>Integrated Infrastructure Initiatives</b>	Type of Action (if necessary)	
Project Title (or Acronym)	<b>CARE</b>	Contract n°	<b>R113-CT-2003-506395/DGRes/F</b>
Contractors's legal name	<b>The University Of Manchester</b>		
Legal Type	<b>University</b>		
Contact Person	<b>Craig Taylor</b>	Telephone	<b>+44(0)1613063027</b>
Telecopy		E-mail	
Cost model used (AC/FC or FCF) (UF: User Fee)(*)	<b>AC</b>	Indirect costs (Real or Flat Rate of 20% of Direct costs, except subcontracting)	<b>20% Total Cost</b>
Period from	<b>01/01/2005</b>	To	<b>31/12/2005</b>

(\*) If UF is used under "other specific activities: transnational access/connectivity", please mention the two cost models used (eg. FC/UF or FCF/UF or AC/UF)

**1- Resources (Third party(ies))**

Are there any resources made available on the basis of a prior agreement with third parties identified in Annex I of the contract? (Yes / No)

No

If Yes, please provide the following information

Third Party 1 (Y1)	Legal name		Cost model used	
--------------------	------------	--	-----------------	--

If necessary add another Form C

**2- Declaration of eligible costs (in €)**

	Type of Activity														Total (G) = (A)+(B)+(C)+ (D)+(E)+(F)	
	Research and Technological Development / Innovation (A)		Demonstration (B)		Management of the Consortium (C)		Other Specific Activities: Coordination / Networking (D)		Other Specific Activities: Transnational Access / Connectivity (E)		Other Specific Activities (F)					
	Contractor	Third Party(ies)	Contractor	Third Party(ies)	Contractor	Third Party(ies)	Contractor	Third Party(ies)	Contractor	Third Party(ies)	Contractor	Third Party(ies)	Contractor	Third Party(ies)		
Direct costs							9 119,71							9 119,71		
Of which subcontracting																
Indirect costs							1 823,94							1 823,94		
Adjustments to previous period(s)																
<b>Total costs</b>	0						10 943,65							10 943,65		

**3- Declaration of receipts (in €)**

If you are a contractor using the additional cost model (AC), indicate only receipts covered by Article II.23.c of the contract.

If you are a contractor using a full cost model (FC/FCF), indicate receipts covered by Article II.23 of the contract.

	Type of Activity														Total (G) = (A)+(B)+(C)+ (D)+(E)+(F)	
	Research and Technological Development / Innovation (A)		Demonstration (B)		Management of the Consortium (C)		Other Specific Activities: Coordination / Networking (D)		Other Specific Activities: Transnational Access / Connectivity (E)		Other Specific Activities (F)					
	Contractor	Third Party(ies)	Contractor	Third Party(ies)	Contractor	Third Party(ies)	Contractor	Third Party(ies)	Contractor	Third Party(ies)	Contractor	Third Party(ies)	Contractor	Third Party(ies)		
<b>Total receipts</b>																

<b>4- Declaration of interest generated by the pre-financing (in €)</b>	
<i>To be completed only by the coordinator.</i>	
<i>Did the pre-financing (advance) you received by the Commission for this period earn interest? (Yes / No)</i>	
<i>If yes, please indicate the amount (in €)</i>	

<b>5- Request of FP6 Financial Contribution (in €)</b>	
<i>For this period, the FP6 Community financial contribution requested is equal to ( amount in €)</i>	10943,65

<b>6- Audit certificates</b>	
<i>According to the contract, does this Financial Statement need an audit certificate (or several in case of Third party(ies)) delivered by independent auditor(s)? (Yes / No)</i>	yes
<i>If Yes, does this(those) audit certificate(s) cover only this Financial Statement per Activity? (Yes / No)</i>	No
<i>If No, what are the periods covered by this(those) audit certificate(s) ?</i>	From - to 01/01/04 - 31/12/05
<i>What is the total cost of this(those) audit certificate(s) (in €) per independent auditor(s) ?</i>	

<b>Audit certificate of the contractor (X)</b>			
Legal name of the audit firm	UNIAC	Cost of the certificate	800
<b>Audit certificate(s) of the third party(ies) (Ys) (if necessary)</b>			
Y1 : Legal name of the audit firm		Cost of the certificate	
<i>If necessary add another Form C.</i>		Total (Z) = (X) + (Ys)	
<i>Reminders:</i>			
<i>The cost of an audit certificate is included in the costs declared under the activity "Management of the Consortium". The required audit certificate (s) is (are) attached to this Financial Statement</i>			

<b>7- Conversion rates Exchange Rate used 0.6865 Sterling to EURP</b>	
Costs incurred in currencies other than EURO shall be reported in EURO.	
Please mention the conversion rate used (only one choice is possible) – Please note that the same principle applies for receipts.	
<b>Contractor</b>	
- Conversion rate of the date of incurred actual costs? (YES / NO)	No
- Conversion rate of the first day of the first month following the period covered by this Financial Statement? (YES/NO)	Yes
<b>Third Party(ies) (if necessary)</b>	
<b>Third Party 1 (Y1)</b>	
- Conversion rate of the date of incurred actual costs? (YES / NO)	
- Conversion rate of the first day of the first month following the period covered by this Financial Statement? (YES/NO)	

If necessary add another Form C.

<b>8- Contractor's Certificate</b>		
We certify that:		
- the costs declared above are directly related to the resources used to reach the objectives of the project ;		
- the receipts declared above are directly related to the resources used to reach the objectives of the project ;		
- the costs declared above fall within the definition of eligible costs specified in Articles II.19, II.20, II.21, II.22 and II.25 of the contract, and, if relevant, in Annex III and Article 9 (special clauses) of the contract ;		
- the receipts declared above fall within the definition of receipts specified in Article II.23 of the contract ;		
- the interest generated by the pre-financing declared above falls within the definition of Article II.27 of the contract ;		
- the necessary adjustments, especially to costs reported in previous Financial Statement(s) per Activity, have been incorporated in the above Statement ;		
- the above information declared is complete and true ;		
- there is full supporting documentation to justify the information hereby declared. It will be made available at the request of the Commission and in the event of an audit by the Commission and/or by the Court of Auditors and/or their authorised representatives.		
<b>Contractor's Stamp</b>	<b>Name of the Person responsible for the work</b>	<b>Name of the duly authorised Financial Officer</b>
	<b>Prof Roger Barlow</b>	<b>Craig Taylor</b>
	<b>Date</b>	<b>Date</b>
	<b>13th February 2006</b>	<b>13th February 2006</b>
	<b>Signature</b>	<b>Signature</b>

**3. Summary financial report**

Summary financial report (Appendix 3).

C. REPORT ON THE DISTRIBUTION OF THE COMMUNITY FINANCIAL CONTRIBUTION

Type of Instrument		13		Project Title (or Acronym)		From (dd/mm/yyyy)		To (dd/mm/yyyy)		Contract N°		Page						
Reporting period number		2		CARE		01/01/2005		31/12/2005		RI3-CT-2003-506395		1/1						
Contractor n°	Contractor Organisation Short Name	Cost model(s) used	Eligible costs (in €)	Type of activities						Other Specific Activities		Total eligible costs		Receipts				
				Research and Technological Development / Innovation (A)		Demonstration (B)		Management of the consortium (C)		Other Specific Activities: Coordination (D)		Other Specific Activities: Transnational Access (E)		Other Specific Activities (F)		(G)+(H)+(I)+(J)+(K)+(L)		(M)+(N)+(O)+(P)
				Contractor	AC Third party(ies)	FC/FCF Third party(ies)	Contractor	AC Third party(ies)	FC/FCF Third party(ies)	Contractor	AC Third party(ies)	UF Third party(ies)	Contractor	AC Third party(ies)	FC/FCF Third party(ies)	Contractor	AC Third party(ies)	FC/FCF Third party(ies)
1	CEA	FC	Direct eligible costs of which direct eligible costs of subcontractors	1 273 255,36												1 427 993,25	0,00	0,00
			Indirect eligible costs													0,00	0,00	0,00
			Adjustment on previous periods)	799 287,36			0,00									999 475,05	0,00	0,00
			Total eligible costs	-1 892,96												-1 892,96	0,00	0,00
				2 070 579,96	0,00	0,00	19 772,69	0,00	0,00	0,00	0,00	0,00	0,00	0,00	0,00	2 275 596,20	0,00	0,00
2	UCLN	AC	Direct eligible costs of which direct eligible costs of subcontractors				170,04									2 070,48	0,00	0,00
			Indirect eligible costs													0,00	0,00	0,00
			Adjustment on previous periods)				394,10									394,10	0,00	0,00
			Total eligible costs	0,00	0,00	0,00	2 424,98	0,00	0,00	0,00	0,00	0,00	0,00	0,00	0,00	2 424,98	0,00	0,00
3	CNRS	FCF	Direct eligible costs of which direct eligible costs of subcontractors	1 241 937,76			16 502,02									1 258 439,78	0,00	42 718,91
			Indirect eligible costs	248 387,55			3 316,52			6 786,48						0,00	0,00	0,00
			Adjustment on previous periods)	8 553,23			-0,10			27 627,31						8 553,13	0,00	32 764,38
			Total eligible costs	1 498 888,54	0,00	0,00	19 898,04	0,00	0,00	68 346,27	0,00	0,00	0,00	0,00	0,00	1 518 737,58	0,00	84 043,64
				218 843,46			6 035,01									224 878,47	0,00	0,00
			Indirect eligible costs													0,00	0,00	0,00
			Adjustment on previous periods)	38 615,05			523,04									38 615,06	0,00	0,00
			Total eligible costs	248 828,51	0,00	0,00	6 558,09	0,00	0,00	0,00	0,00	0,00	0,00	0,00	0,00	252 882,33	0,00	0,00
				69 375,36			6 035,01									69 945,33	0,00	0,00
			Indirect eligible costs													0,00	0,00	0,00
			Adjustment on previous periods)	13 875,68												13 875,68	0,00	0,00
			Total eligible costs	83 251,04	0,00	0,00	6 035,01	0,00	0,00	0,00	0,00	0,00	0,00	0,00	0,00	83 251,04	0,00	0,00
				377 219,48			51 381,14									428 600,62	0,00	0,00
			Indirect eligible costs	27 650,01												27 650,01	0,00	0,00
			Adjustment on previous periods)	69 913,95			10 276,24									80 190,19	0,00	0,00
			Total eligible costs	474 783,44	0,00	0,00	61 657,38	0,00	0,00	0,00	0,00	0,00	0,00	0,00	0,00	474 783,44	0,00	0,00
				312 508,27			4 336,78									316 845,05	0,00	0,00
			Indirect eligible costs													0,00	0,00	0,00
			Adjustment on previous periods)	219 390,36			-45,47									219 344,89	0,00	0,00
			Total eligible costs	540 398,11	0,00	0,00	4 291,31	0,00	0,00	0,00	0,00	0,00	0,00	0,00	0,00	540 398,11	0,00	0,00
							2287,04									2 287,04	0,00	0,00
			Indirect eligible costs													0,00	0,00	0,00
			Adjustment on previous periods)				453,40									453,40	0,00	0,00
			Total eligible costs	0,00	0,00	0,00	2 740,44	0,00	0,00	0,00	0,00	0,00	0,00	0,00	0,00	2 740,44	0,00	0,00





## C. REPORT ON THE DISTRIBUTION OF THE COMMUNITY FINANCIAL CONTRIBUTION

**Report on the distribution between contractors made during the reporting period of the  
Community financial contribution**



Report on the Distribution of the Community's contribution

Type of Instrument		13	Project Title (or Acronym)		CARE		Contract N°		RII3-CT-2003-506395											
Community's prefunding (or payment) sent to the coordinator (r)																				
Reporting Period 1 (2)		Reporting Period 2 (2)		Reporting Period 3 (2)		Reporting Period 4 (2)		Reporting Period 5 (2)		Reporting Period 6 (2)		Reporting Period 7 (2)		Reporting Period 8 (2)		Final payment		Total Amount (l) (3)		
From	To	From	To	From	To	From	To	From	To	From	To	From	To	Date	Amount (H)	Date	Amount (G)	Total	Amount (I) (3)	
EC	CEA	EC	CEA	EC	CEA	EC	CEA	EC	CEA	EC	CEA	EC	CEA							
Date	Amount (A)	Date	Amount (B)	Date	Amount (C)	Date	Amount (D)	Date	Amount (E)	Date	Amount (F)	Date	Amount (G)							
15/03/2004	5 235 000,00 €	24/06/2005	4 927 837,00 €																	10 162 837,00 €
Distribution of the Community's prefunding (or payment) between contractors according to the consortium decision(s) (4)																				
Contractor n°	Organisation Short Name	Country Code	Reporting Period 1		Reporting Period 2		Reporting Period 3		Reporting Period 4		Reporting Period 5		Reporting Period 6		Reporting Period 7		Final payment		Total Amount (l) (6)	
			Date(s) (5)	Amount(s) (A) (5)	Date(s) (5)	Amount(s) (B) (5)	Date(s) (5)	Amount(s) (C) (5)	Date(s) (5)	Amount(s) (D) (5)	Date(s) (5)	Amount(s) (E) (5)	Date(s) (5)	Amount(s) (F) (5)	Date(s) (5)	Amount(s) (G) (5)	Date(s) (5)	Amount(s) (H) (5)		
1	CEA	F	9/04/2004	653 490,00 €	24/06/2005	1 253 107,00 €													1 906 597,00 €	
			Total	653 490,00 €	Total	1 253 107,00 €														1 906 597,00 €
2	UCLN	B	19/04/2004	1 425,00 €	1/07/2005	1 200,00 €													2 625,00 €	
			Total	1 425,00 €	Total	1 200,00 €														2 625,00 €
3	CNRS	F	30/04/2004	831 242,00 €	1/07/2005	746 540,00 €													1 577 782,00 €	
			Total	831 242,00 €	Total	746 540,00 €														1 577 782,00 €
4	GSI	D	19/04/2004	133 554,00 €	1/05/2005	167 860,00 €													301 414,00 €	
			Total	133 554,00 €	Total	167 860,00 €														301 414,00 €
5	IAP-FU	D	3/05/2004	108 732,00 €	1/07/2005	137 110,00 €													245 842,00 €	
			Total	108 732,00 €	Total	137 110,00 €														245 842,00 €
6	DESJ	D	19/04/2004	638 912,00 €	1/07/2005	234 790,00 €													873 702,00 €	
			Total	638 912,00 €	Total	234 790,00 €														873 702,00 €
7	FZJ	D	22/04/2004	124 405,00 €	1/07/2005	214 400,00 €													338 805,00 €	
			Total	124 405,00 €	Total	214 400,00 €														338 805,00 €
8	TUM	D	30/04/2004	2 325,00 €	1/07/2005	1 050,00 €													3 375,00 €	
			Total	2 325,00 €	Total	1 050,00 €														3 375,00 €
9	FZR-ELBE	D	19/04/2004	147 726,00 €	1/07/2005	109 740,00 €													257 466,00 €	
			Total	147 726,00 €	Total	109 740,00 €														257 466,00 €
10	INFN	I	19/04/2004	780 160,00 €	1/07/2005	345 570,00 €													1 125 730,00 €	
			Total	780 160,00 €	Total	345 570,00 €														1 125 730,00 €

**Report on the Distribution of the Community's contribution**

Type of Instrument		13	Project title (or Acronym)		CARE		Contract N°		RI3-CT-2003-506395										
<b>Part II</b>																			
<b>Distribution of the Community's prefinancing (or payment) between contractors according to the consortium decision(s) (4)</b>																			
Contractor n°	Organisation Short Name	Country Code	Reporting Period 1		Reporting Period 2		Reporting Period 3		Reporting Period 4		Reporting Period 5		Reporting Period 6		Reporting Period 7		Final payment Amount(s) (H) (6)	Total Amount (I) (6)	
			Date(s) (g)	Amount(s) (A) (6)	Date(s) (g)	Amount(s) (B) (6)	Date(s) (g)	Amount(s) (C) (6)	Date(s) (g)	Amount(s) (D) (6)	Date(s) (g)	Amount(s) (E) (6)	Date(s) (g)	Amount(s) (F) (6)	Date(s) (g)	Amount(s) (G) (6)			
11	TEU	PL	19/04/2004	111 545,00 €	1/07/2005	83 400,00												194 945,00 €	
																			0,00 €
			<b>Total</b>	<b>111 545,00 €</b>	<b>1/07/2005</b>	<b>83 400,00</b>													
12	TUL Lodz	PL	20/04/2004	100 904,00 €	1/07/2005	61 250,00												162 154,00 €	
																			0,00 €
			<b>Total</b>	<b>100 904,00 €</b>	<b>1/07/2005</b>	<b>61 250,00</b>													
13	IPJ	PL	20/04/2004	93 885,00 €	1/07/2005	86 640,00												180 525,00 €	
																			0,00 €
			<b>Total</b>	<b>93 885,00 €</b>	<b>1/07/2005</b>	<b>86 640,00</b>													
14	PW (WUT-ISE)	PL	20/04/2004	146 526,00 €	1/07/2005	134 830,00												281 356,00 €	
																			0,00 €
			<b>Total</b>	<b>146 526,00 €</b>	<b>1/07/2005</b>	<b>134 830,00</b>													
15	WUT	PL	20/04/2004	40 119,00 €	1/07/2005	12 000,00												52 119,00 €	
																			0,00 €
			<b>Total</b>	<b>40 119,00 €</b>	<b>1/07/2005</b>	<b>12 000,00</b>													
16	CSIC	SP	30/04/2004	11 473,00 €	1/07/2005	11 670,00												23 143,00 €	
																			0,00 €
			<b>Total</b>	<b>11 473,00 €</b>	<b>1/07/2005</b>	<b>11 670,00</b>													
17	CERN	CH	19/04/2004	1 069 328,00 €	1/07/2005	1 117 320,00												2 186 648,00 €	
																			0,00 €
			<b>Total</b>	<b>1 069 328,00 €</b>	<b>1/07/2005</b>	<b>1 117 320,00</b>													
18	UNI-GE	CH		0,00 €														0,00 €	
																			0,00 €
			<b>Total</b>	<b>0,00 €</b>															
19	PSI	CH		0,00 €														0,00 €	
																			0,00 €
			<b>Total</b>	<b>0,00 €</b>															
20	CCLRC	GB	20/04/2004	209 029,00 €	1/07/2005	189 900,00												398 929,00 €	
																			0,00 €
			<b>Total</b>	<b>209 029,00 €</b>	<b>1/07/2005</b>	<b>189 900,00</b>													
21	ICL	GB	30/04/2004	20 472,00 €	1/07/2005	11 820,00												32 292,00 €	
																			0,00 €
			<b>Total</b>	<b>20 472,00 €</b>	<b>1/07/2005</b>	<b>11 820,00</b>													
22	UMA	GB	20/04/2004	9 748,00 €	1/07/2005	7 550,00												17 298,00 €	
																			0,00 €
			<b>Total</b>	<b>9 748,00 €</b>	<b>1/07/2005</b>	<b>7 550,00</b>													

**Report on the Distribution of the Community's contribution**

<b>Type of Instrument</b>		13		<b>Project Title (or Acronym)</b>		GARE		<b>Contract N°</b>		RII3-CT-2003-506395									
<b>Part II</b>																			
Distribution of the Community's prefinancing (or payment) between contractors according to the consortium decision(s) (4)																			
Contractor n°	Organisation Short Name	Country Code	Reporting Period 1		Reporting Period 2		Reporting Period 3		Reporting Period 4		Reporting Period 5		Reporting Period 6		Reporting Period 7		Final payment		Total Amount (I) (6)
			Date(s) (5)	Amount(s) (A) (6)	Date(s) (5)	Amount(s) (B) (6)	Date(s) (5)	Amount(s) (C) (6)	Date(s) (5)	Amount(s) (D) (6)	Date(s) (5)	Amount(s) (E) (6)	Date(s) (5)	Amount(s) (F) (6)	Date(s) (5)	Amount(s) (G) (6)	Date(s) (5)	Amount(s) (H) (6)	
Total (Y)			5 235 000,00 €		4 927 837,00 €		0,00		0,00		0,00		0,00		0,00		0,00		10 162 837,00 €

<b>Part III</b>																			
Difference between Community's prefinancing (or payment) sent to the coordinator and Total Distribution of the Community's prefinancing (or payment) between contractors according to the consortium decision(s) (4)																			
Community's prefinancing (or payment) not yet distributed between contractors (Z) (7)			Reporting Period 1		Reporting Period 2		Reporting Period 3		Reporting Period 4		Reporting Period 5		Reporting Period 6		Reporting Period 7		Final payment		Total Amount
			0,00		0,00		0,00		0,00		0,00		0,00		0,00		0,00		0,00

I certify that the information set out in this (these) form(s) is accurate and correct and agreed by all contractors.

<b>Name (8)</b>		<b>Surname (8)</b>		<b>Date (dd/mm/yyyy)</b>		<b>Signature of the administrative official authorised to commit the organisation of the coordinator (8)</b>					
Aleksan		Roy		10/01/2005							

**Explanatory notes**

- (1): To be filled in only by the Commission services.
- (2): Established in conformity with articles 4.2 and 6 of the contract.
- (3): (I) = (A) + (B) + (C) + (D) + (E) + (F) + (G) + (H)
- (4): To be filled in only by the coordinator.
- (5): Insert the dates (dd/mm/yyyy) and the amounts (x.xxx.xx €) transferred to a contractor (including the coordinator) for a reporting period. If there are more than one transfer to a contractor during a reporting period, identify each date and each relating transferred amount.
- (6): (I) = (A) + (B) + (C) + (D) + (E) + (F) + (G) + (H)
- (7): (Z) = (X) - (Y)
- (8): One the following persons : authorised contact person or first or second administrative official authorised to sign the contract, as mentioned in your Contract Preparation Form (Form A2b)

**D. Detailed Implementation Plan for the next 18 months**

The following Gantt charts present the updated detailed implementation plan for the next 18 months for the three CARE networking activities and the four CARE joint research activities. They are supplemented by tables providing the corresponding financial information.

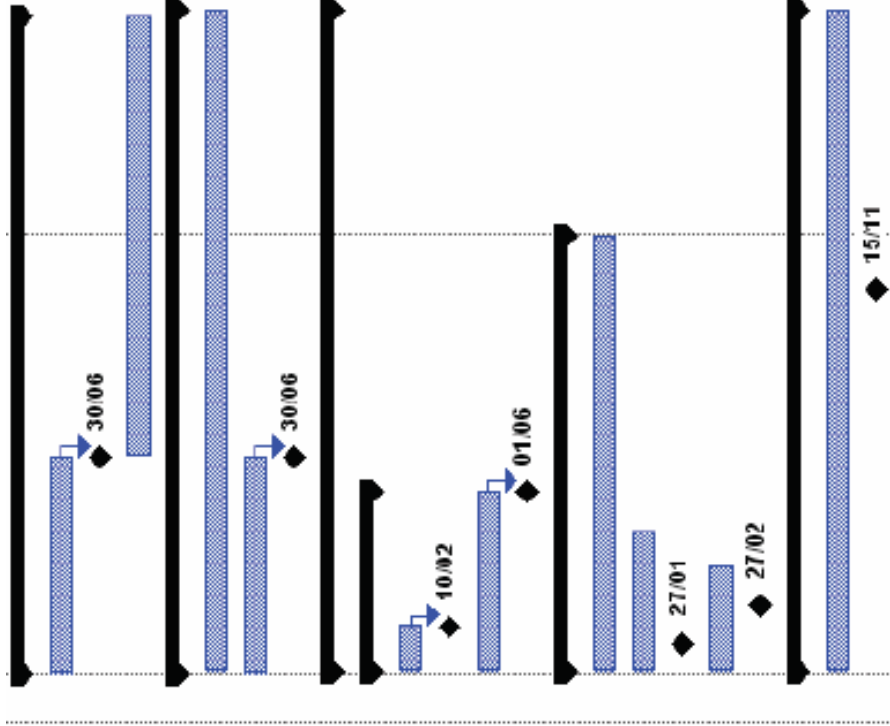
**NETWORKING ACTIVITIES (other than Management)**

**N1 Electron Linear Accelerator Network (ELAN)**

N°	Task Name	2006				2007							
		Tri 4	Tri 1	Tri 2	Tri 3	Tri 4	Tri 1	Tri 2	Tri 3	Tri 4			
1	<b>Review of network activity</b>												
2	Annual Meeting												
3	Annual Report												
4	Coordination with the GDE												
5	<b>WP 1</b>												
6	Progress on CTF3												
7	Annual review of CTF3 results												
8	Proceedings of CTF3 collaboration												
9	Progress on LITECNC topics, incl. topics common with other WVP												
10	Associated documents												
11	Review of structure prototype results												
12	Document on status												
13	Review report												
14	Review on sources including outcome of PHIN												
15	<b>WP 2</b>												
16	<b>ILC Technology Development</b>												
17	Monitor ILC preparation												
18	Coordinate work together with EUROTeV												
19	Build Database for SRF												
20	MS: Database												
21	Develop cavity reliability roadmap												
22	MS: Workshop (TTC Meeting I)												
23	Evaluation of quality control												
24	Evaluation of cleaning methods												
25	MS: Workshop (TTC Meeting II)												

D. DETAILED IMPLEMENTATION PLAN FOR THE NEXT 18 MONTHS

26	<b>WP 3</b>
27	Coordinate R&D toward ODE workshop
28	Workshop
29	Coordinate further R&D
30	<b>WP 4</b>
31	Coordinate R&D
32	Review progress and finalise designs on the ILC diagnostics sections
33	MS: Workshop
34	<b>WP5</b>
35	<b>Extended plasma wave excitation</b>
36	Evaluate existing laser guiding techniques
37	ID: Document
38	Identify optical diagnostics
39	ID: Document
40	<b>Coordinate European Proposals</b>
41	Coordination of NEST and RTN proposals
42	Preparation of NEST contract if EUROLEAP successful
43	Meeting
44	Preparation of RTN proposal if 1st step successful
45	Meeting
46	<b>Monitor progress of on-going projects</b>
47	Build database of plasma accelerators
48	Meeting



## N2 Beam for European Neutrino Physics (BENE)

Nom de la tâche	2006				2007				2008				
	Tr 4	Tr 1	Tr 2	Tr 3	Tr 4	Tr 1	Tr 2	Tr 3	Tr 4	Tr 1	Tr 2	Tr 3	Tr 4
N2: BENE Networking activities													
All Work Packages													
Proceed resolutely towards Design Study Proposal. Assemble the continental collaboration.													
WP1: Physics. Consolidate WP. Advance towards consensusal comparison of physics options for DS Proposal.													
Review studies adjust priorities, plans, organization.													
Reinforce connections in WP. Review work & priorities of WP. Improve WP Website													
Focus WP on ISS. Revisit existing preliminary assessments of physics reach using common yardsticks and tools													
WP Spring Meeting and meeting of the Physics Council of the ISS													
WP Summer Meeting at NuFact06 Workshop (plus reserve date)													
WP contributions to Proceedings NuFact06 International Workshop													
WP Fall Meeting at BENE06 meeting													
WP Annual Report 2006													
WP Winter Meeting													
MD: Physics Section DS Proposal													
WP Summer Meeting at NuFact07 International Workshop													
WP contribution to NuFact07 International Workshop													
WP2: Driver. Consolidate WP framework. Define program of Design Study in driver sector.													
Review studies adjust priorities, plans, organization.													
Reinforce connections in WP. Review work & priorities of WP. Improve WP Website													
Focus WP on ISS. Define plan of study and further R&D for the three driver options (SPL, RCS, FFAG)													
WP Spring Meeting and meeting of the driver section of Accelerator council of the ISS													
WP Summer Meeting at NuFact06 Workshop (plus reserve date)													
WP contributions to Proceedings NuFact06 International Workshop													
WP Fall Meeting at BENE06 meeting													
WP Annual Report 2006													
WP Winter Meeting													
MD: Driver Section DS Proposal													
WP Summer Meeting at NuFact07 Workshop (plus reserve date)													
WP contribution to NuFact07 International Workshop													
WP3: Target. Consolidate WP framework. Define program of Design Study in target sector.													
Review studies adjust priorities, plans, organization.													
Reinforce connections in WP. Review work & priorities of WP. Improve WP Website													
Focus WP on ISS. Define plan of study and further R&D for the solid, granular and liquid target options.													
WP Spring Meeting and meeting of the target section of Accelerator council of the ISS													
WP Summer Meeting at NuFact06 Workshop (plus reserve date)													
WP contributions to Proceedings NuFact06 International Workshop													
WP Fall Meeting at BENE06 meeting													
WP Annual Report 2006													
WP Winter Meeting													
MD: Target Section DS Proposal													
WP Summer Meeting at NuFact07 Workshop (plus reserve date)													



D. DETAILED IMPLEMENTATION PLAN FOR THE NEXT 18 MONTHS

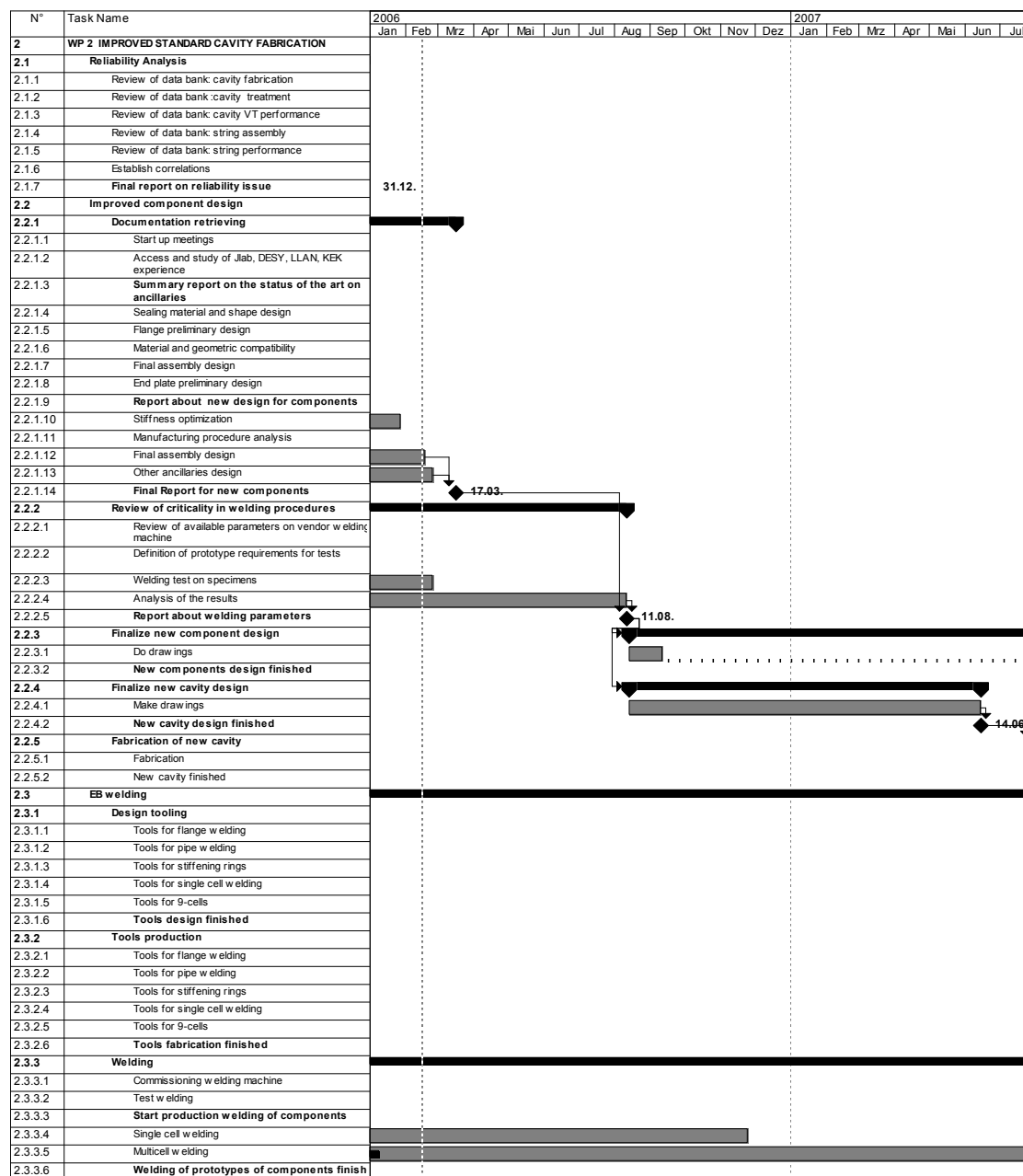
Nom de la tâche	2006				2007				2008				
	Tri 4	Tri 1	Tri 2	Tri 3	Tri 4	Tri 1	Tri 2	Tri 3	Tri 4	Tri 1	Tri 2	Tri 3	Tri 4
WP contribution to NuFact07 International Workshop													
<b>WP4: Collector. Consolidate WP framework. Define program of Design Study in collector sector.</b>													
Review studies adjust priorities, plans, organization.													
Reinforce connections in WP. Review work & priorities of WP. Improve WP Website													
Focus WP on ISS. Plan of studies & R&D for scientific & horns on tradition, mechanical & thermal stresses & on infrastructures.													
WP Spring Meeting and meeting of the collector section of Accelerator council of the ISS													
WP Summer Meeting at NuFact05 Workshop (plus reserve date)													
WP contributions to Proceedings NuFact05 International Workshop													
WP Fall Meeting at BENE06 meeting													
WP Annual Report 2006													
WP Winter Meeting													
MD: Collector Section DS Proposal													
WP Summer Meeting at NuFact05 Workshop (plus reserve date)													
WP contribution to NuFact07 International Workshop													
<b>WP5: Novel Neutrino Beams. Consolidate WP framework. Define program of Design Study for NuFact and Betabeam</b>													
Review studies adjust priorities, plans, organization.													
Reinforce connections in WP. Review work & priorities of WP. Improve WP Website													
Focus WP on ISS. Define plan of study and further R&D for the manipulation, acceleration, storage of muons and ions													
WP Spring Meeting and meeting of the muon and ion manipulation section of Accelerator council of the ISS													
WP Summer Meeting at NuFact05 Workshop (plus reserve date)													
WP contributions to Proceedings NuFact05 International Workshop													
WP Fall Meeting at BENE06 meeting													
WP Annual Report 2006													
WP Winter Meeting													
MD: Novel Beams Section DS Proposal													
WP Summer Meeting at NuFact05 Workshop (plus reserve date)													
WP contribution to NuFact07 International Workshop													

### N3 High Energy High Intensity Hadron Beams (HHH)

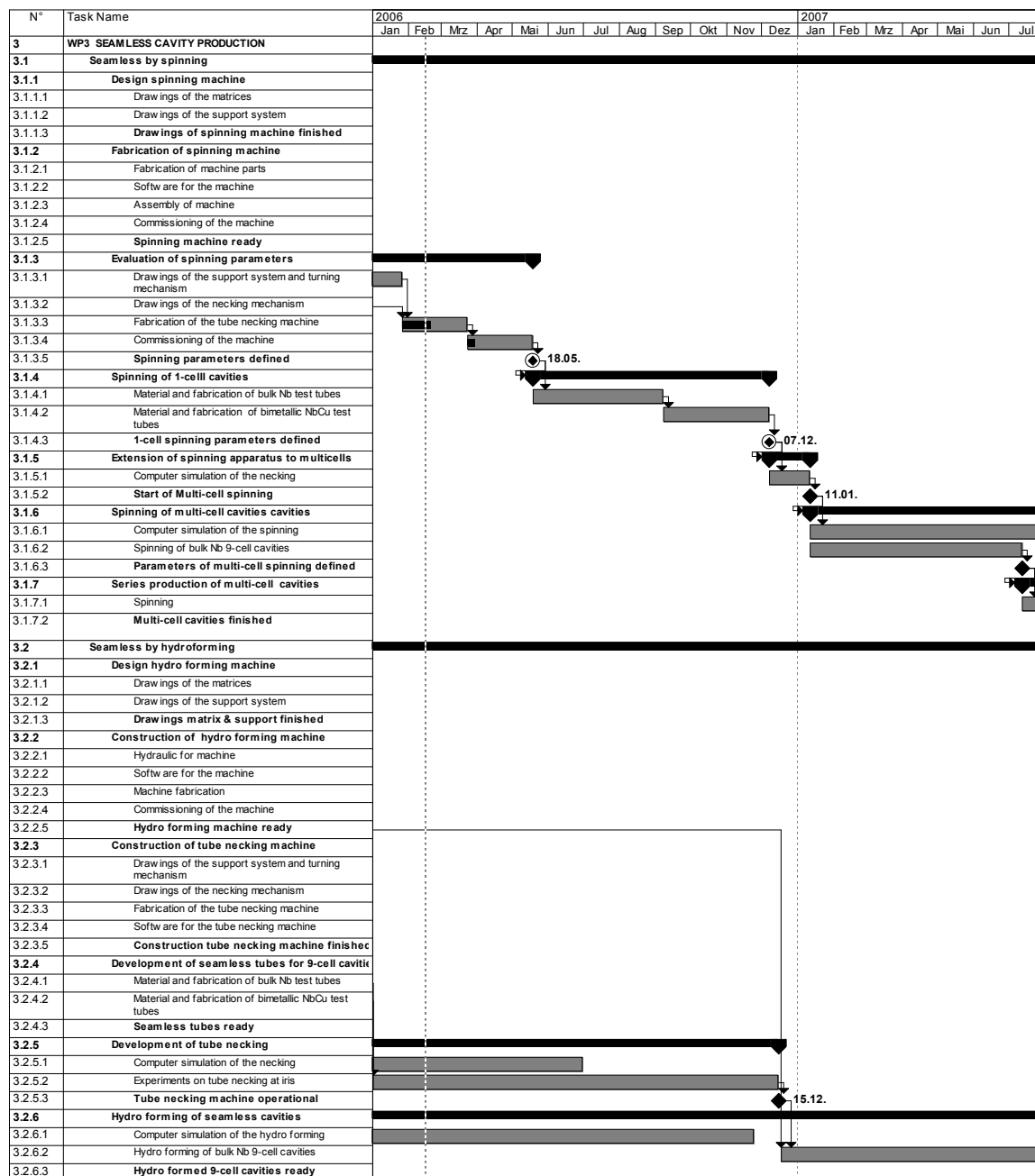


## JOINT RESEARCH ACTIVITIES

### JRA1: Superconducting Radio Frequency (SRF)



D. DETAILED IMPLEMENTATION PLAN FOR THE NEXT 18 MONTHS



D. DETAILED IMPLEMENTATION PLAN FOR THE NEXT 18 MONTHS

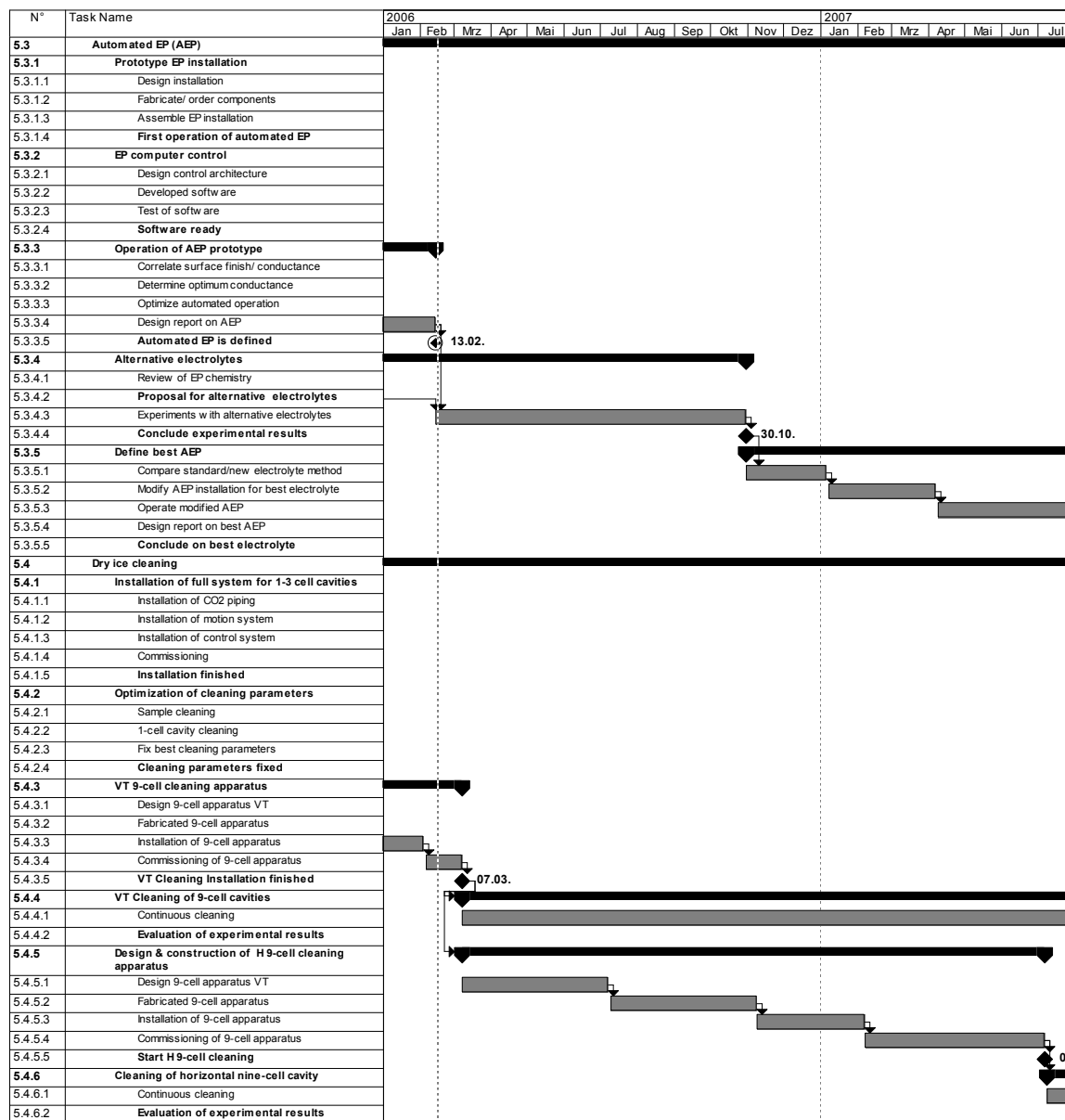
N°	Task Name	2006												2007					
		Jan	Feb	Mrz	Apr	Mai	Jun	Jul	Aug	Sep	Okt	Nov	Dez	Jan	Feb	Mrz	Apr	Mai	Jun
<b>4</b>	<b>WP4 THIN FILM CAVITY PRODUCTION</b>																		
<b>4.1</b>	<b>Linear-arc cathode coating</b>																		
<b>4.1.1</b>	<b>Installation &amp; commissioning of coating apparatus</b>																		
4.1.1.1	Modification of a prototype facility for single cells																		
4.1.1.2	Optimization of a triggering system																		
4.1.1.3	<b>Prototype facility ready</b>																		
4.1.1.4	Study of arc current reduction and stabilization																		
4.1.1.5	Optimization of powdering system																		
4.1.1.6	<b>Coating apparatus operational</b>																		
4.1.1.7	<b>Coating single cells</b>																		
4.1.1.7.1	Coating of single cells without micro droplet filtering																		
4.1.1.7.2	Design and construction of a micro droplet filter																		
4.1.1.7.3	<b>Droplet filter ready</b>																		
4.1.1.7.4	Coating of single cell with micro droplet filtering																		
<b>4.1.2</b>	<b>Coating multi-cell</b>																		
4.1.2.1	Design and commissioning																		
4.1.2.2	First multicell coating																		
<b>4.2</b>	<b>Planar-arc cathode coating</b>																		
<b>4.2.1</b>	<b>Modification of a planar-arc &amp; trigger system</b>																		
4.2.1.1	Modification																		
4.2.1.2	Optimization of the laser triggering system																		
4.2.1.3	<b>Planar arc system fully tested</b>																		
<b>4.2.2</b>	<b>Routine Operation of planar arc system</b>																		
4.2.2.1	Characterization of samples coated at different conditions																		
4.2.2.2	Characterization of Nb-coated sapphire sam																		
4.2.2.3	Characterization of Nb-coated copper sampl																		
4.2.2.4	<b>Summary report on quality of planar arc coating</b>																		
<b>4.2.3</b>	<b>Studies of other HTC superconducting coating</b>																		
4.2.3.1	Study of superconducting properties																		
4.2.3.2	<b>Report on quality of superconducting properties</b>																		

30.0

D. DETAILED IMPLEMENTATION PLAN FOR THE NEXT 18 MONTHS

N°	Task Name	2006												2007						
		Jan	Feb	Mrz	Apr	Mai	Jun	Jul	Aug	Sep	Okt	Nov	Dez	Jan	Feb	Mrz	Apr	Mai	Jun	Jul
<b>5</b>	<b>WP5 SURFACE PREPARATION</b>																			
<b>5.1</b>	<b>EP on single cells</b>																			
<b>5.1.1</b>	<b>EP on samples</b>																			
5.1.1.1	Establishing method of surface characterization																			
5.1.1.2	<b>Surface characterization fixed</b>																			
5.1.1.3	Series of EP with samples for surface investigations																			
5.1.1.4	<b>Best EP parameters</b>																			
<b>5.1.2</b>	<b>Single cell cavities</b>																			
5.1.2.1	Order Nb and fabricate 3 cavities																			
5.1.2.2	<b>3 cavities fabricated</b>																			
<b>5.1.3</b>	<b>Build EP chemistry for single cells</b>																			
5.1.3.1	Design of EP set-up																			
5.1.3.2	Fabrication of EP set-up																			
5.1.3.3	Commissioning of EP set-up																			
5.1.3.4	<b>First operation of EP set-up</b>																			
<b>5.1.4</b>	<b>Operation of single cell EP</b>																			
5.1.4.1	Continuous single cell operation																			
5.1.4.2	<b>Define working parameters for single cells</b>																			
<b>5.1.5</b>	<b>Continuous operation, search for best paramete</b>																			
5.1.5.1	Parametrising EP procedure																			
5.1.5.2	<b>EP parameters fixed</b>																			
<b>5.2</b>	<b>EP on multi-cells</b>																			
<b>5.2.1</b>	<b>Transfer of parameters from 1 cell to multi cell equipment</b>																			
<b>5.2.1.1</b>	<b>Finish EP setup nine-cells at DESY</b>																			
5.2.1.1.1	Improved gas cleaning system																			
5.2.1.1.2	Design for hot water rinsing																			
5.2.1.1.3	<b>Proof-of-Principle experiment hot water rinsing</b>																			
<b>5.2.1.2</b>	<b>Optimize electrode shape</b>																			
5.2.1.2.1	Develop computer model / Evaluate software																			
5.2.1.2.2	Design improved electrode																			
5.2.1.2.3	<b>Electrode design fixed</b>																			
<b>5.2.1.3</b>	<b>Fix process parameters/ Quality control</b>																			
5.2.1.3.1	Setup chemical lab																			
5.2.1.3.2	Bath aging																			
5.2.1.3.3	Bath mixture																			
5.2.1.3.4	Alternative (salt) mixtures																			
5.2.1.3.5	<b>Process parameters fixed</b>																			
<b>5.2.2</b>	<b>Laser roughness</b>																			
5.2.2.1	Evaluate existing systems																			
5.2.2.2	Specify laser system																			
5.2.2.3	Built laser system																			
5.2.2.4	<b>Roughness measurement finished</b>																			
<b>5.2.3</b>	<b>Oxipolishing as final chemical cleaning</b>																			
5.2.3.1	Laboratory studies																			
5.2.3.2	Design of OP system																			
5.2.3.3	Setup one-cell system																			
5.2.3.4	<b>Proof-of-Principle experiment Oxipolishing</b>																			
5.2.3.5	Design OP for nine-cells																			
5.2.3.6	Build OP for 9-cells																			
5.2.3.7	<b>OP for 9-cells ready</b>																			
5.2.3.8	Study op with 9-cell cavities																			
5.2.3.9	Evaluate experiments																			
<b>5.2.4</b>	<b>Transfer Electropolishing technology to industry</b>																			
5.2.4.1	Qualify industry with one-cells																			
5.2.4.2	Industrial design study on setup for multi-cells																			
5.2.4.3	<b>Report on industrial design</b>																			
5.2.4.4	Fabricate EP multi-cell industrial prototype																			
5.2.4.5	Commission EP multi-cell industrial prototype																			
5.2.4.6	<b>EP multi-cell industrial prototype ready</b>																			
5.2.4.7	Operate EP multi-cell industrial prototype																			
5.2.4.8	<b>Final report on industrial EP</b>																			

D. DETAILED IMPLEMENTATION PLAN FOR THE NEXT 18 MONTHS





D. DETAILED IMPLEMENTATION PLAN FOR THE NEXT 18 MONTHS

N°	Task Name	2006												2007						
		Jan	Feb	Mrz	Apr	Mai	Jun	Jul	Aug	Sep	Okt	Nov	Dez	Jan	Feb	Mrz	Apr	Mai	Jun	Jul
<b>6</b>	<b>WP6 MATERIAL ANALYSIS</b>																			
<b>6.1</b>	<b>SQUID scanning</b>																			
<b>6.1.1</b>	<b>Produce calibration defects</b>																			
6.1.1.1	Production of surface defects																			
6.1.1.2	Production of bulk defects																			
6.1.1.3	Calibration defects finished																			
<b>6.1.2</b>	<b>Design components of Squid scanner</b>																			
6.1.2.1	Design of the scanning table and support																			
6.1.2.2	Design of the SQUID cooling system																			
6.1.2.3	Design Scanner finished																			
<b>6.1.3</b>	<b>Construction of scanning apparatus</b>																			
6.1.3.1	Fabrication of the SQUID																			
6.1.3.2	Fabrication and purchase of components for SQUID apparatus																			
6.1.3.3	Softw are for the SQUID scanner																			
6.1.3.4	Commissioning and calibration of scanning apparatus																			
6.1.3.5	Scanning apparatus operational																			
<b>6.1.4</b>	<b>Scanning of sheets with artificial defects</b>																			
6.1.4.1	Scanning of sheets with artificial surface defects																			
6.1.4.2	Scanning of sheets with artificial bulk defects																			
6.1.4.3	Development of algorithm for material defects classification																			
6.1.4.4	Classification of defects finished																			
<b>6.1.5</b>	<b>Scanning of production sheets</b>																			
6.1.5.1	Scanning of sheets of different producers																			
6.1.5.2	Identification of defects by (EDX, SURFA etc.)																			
6.1.5.3	Conclusive comparison with eddy current data																			
6.1.5.4	Final report on SQUID scanning																			
<b>6.2</b>	<b>Flux gate magnetometry</b>																			
<b>6.2.1</b>	<b>Produce calibration defects</b>																			
6.2.1.1	Production of surface defects																			
6.2.1.2	Production of bulk defects																			
6.2.1.3	Calibration defects finished																			
<b>6.2.2</b>	<b>Design components of flux gate head</b>																			
6.2.2.1	Design electronics																			
6.2.2.2	Design of flux gate head																			
6.2.2.3	Design of operations softw are																			
6.2.2.4	Design flux gate head finished																			
<b>6.2.3</b>	<b>Fabrication of flux gate detector</b>																			
6.2.3.1	Fabrication of flux gate head																			
6.2.3.2	Fabrication of mechanics																			
6.2.3.3	Implementation of softw are																			
6.2.3.4	Commissioning of flux gate detector																			
6.2.3.5	Calibration of flux gate detector																			
6.2.3.6	Flux gate detector operational																			
<b>6.2.4</b>	<b>Commissioning of flux gate detector</b>																			
6.2.4.1	Operational tets tests																			
6.2.4.2	Evaluation of test results																			
6.2.4.3	Flux gate scanner commissioned																			
<b>6.2.5</b>	<b>Operation of flux gate detector</b>																			
6.2.5.1	Regular operation																			
6.2.5.2	Report of operation																			
6.2.5.3	Conclusion of flux gate scanning operation																			
<b>6.2.6</b>	<b>Comparison with SQUID scanner</b>																			
6.2.6.1	Compare measurements																			
6.2.6.2	Conclude SQUID scanner vs. flux gate detector																			
<b>6.3</b>	<b>DC field emission studies of Nb samples</b>																			
<b>6.3.1</b>	<b>Quality control scans</b>																			
6.3.1.1	Modification of Scanning apparatus																			
6.3.1.2	Calibration of Scanning apparatus																			
6.3.1.3	Start scanning activity																			
6.3.1.4	BCP and HPR samples																			
6.3.1.5	EP and HPR samples																			
6.3.1.6	BCP/EP and DIC samples																			
6.3.1.7	First report on BCP/EP and DIC surface																			
6.3.1.8	Continue QA scanning																			
6.3.1.9	Evaluation of scanning results																			
<b>6.3.2</b>	<b>Detailed measurements on strong emitters</b>																			
6.3.2.1	Calibrate apparatus for high current																			
6.3.2.2	Start strong emitter evaluation																			
6.3.2.3	IV curves and current limits																			
6.3.2.4	SEM and AES																			
6.3.2.5	Influence of heat treatment and ion impact																			
6.3.2.6	Evaluate strong emitter investigations																			

D. DETAILED IMPLEMENTATION PLAN FOR THE NEXT 18 MONTHS

N°	Task Name	2006												2007						
		Jan	Feb	Mrz	Apr	Mai	Jun	Jul	Aug	Sep	Okt	Nov	Dez	Jan	Feb	Mrz	Apr	Mai	Jun	Jul
<b>7</b>	<b>WP7 COUPLERS</b>																			
<b>7.1</b>	<b>New Prototype Coupler</b>	[Gantt bar from Jan 2006 to Jul 2006]																		
7.1.1	RF Simulations of Coupler	[Gantt bar from Jan 2006 to Jul 2006]																		
7.1.2	Report on Simulation	[Gantt bar from Jan 2006 to Jul 2006]																		
7.1.3	Detailed Engineering Draw ings	[Gantt bar from Jan 2006 to Jul 2006]																		
7.1.4	Engineering complete	[Gantt bar from Jan 2006 to Jul 2006]																		
7.1.5	Call for tenders	[Gantt bar from Jan 2006 to Jul 2006]																		
7.1.6	Prototype Fabrication in Industry	[Gantt bar from Jan 2006 to Jul 2006]																		
7.1.7	Low Power tests	[Gantt bar from Jun 2006 to Jul 2006]																		
7.1.8	<b>Ready for High Power Tests</b>	[Milestone diamond at Jul 2006 labeled 15.07.]																		
<b>7.2</b>	<b>Fabrication of TIN Coating System</b>	[Gantt bar from Jan 2006 to Dec 2006]																		
7.2.1	Mechanical design of vacuum chamber	[Gantt bar from Jan 2006 to Dec 2006]																		
7.2.2	Fabrication draw ings	[Gantt bar from Jan 2006 to Dec 2006]																		
7.2.3	Construction of vacuum chamber	[Gantt bar from Jan 2006 to Dec 2006]																		
7.2.4	Define vacuum needs	[Gantt bar from Apr 2006 to Jul 2006]																		
7.2.5	Appropriation of vacuum equipment	[Gantt bar from Jul 2006 to Oct 2006]																		
7.2.6	Design of electronic circuitry	[Gantt bar from Jan 2006 to Apr 2006]																		
7.2.7	Fabrication of electronics in industry	[Gantt bar from Apr 2006 to Oct 2006]																		
7.2.8	Installation and Test at Orsay	[Gantt bar from Oct 2006 to Dec 2006]																		
7.2.9	<b>First Window Coating</b>	[Milestone diamond at Dec 2006 labeled 01.12.]																		
<b>7.3</b>	<b>Conditioning Studies of Proto-type Couplers</b>	[Gantt bar from Jan 2006 to Dec 2006]																		
7.3.1	Conditioning of couplers	[Gantt bar from Jan 2006 to Dec 2006]																		
7.3.2	Evaluate conditioning results	[Gantt bar from Jan 2006 to Dec 2006]																		
7.3.3	<b>Final report on conditioning</b>	[Gantt bar from Jan 2006 to Dec 2006]																		

D. DETAILED IMPLEMENTATION PLAN FOR THE NEXT 18 MONTHS

N°	Task Name	2006												2007						
		Jan	Feb	Mrz	Apr	Mai	Jun	Jul	Aug	Sep	Okt	Nov	Dez	Jan	Feb	Mrz	Apr	Mai	Jun	Jul
<b>8</b>	<b>WP8 TUNERS</b>																			
<b>8.1</b>	<b>UMI TUNER</b>																			
8.1.1	Control electronics																			
8.1.2	Mechanical tuner design, leverage system/motor																			
8.1.3	Integration piezo design																			
8.1.4	Choice of transducer/actuator																			
8.1.5	<b>Report UMI tuner</b>																			
8.1.6	Tuner fabrication																			
8.1.7	Piezo fabrication and bench tests																			
8.1.8	Cavity-tuner-coupler integration																			
8.1.9	Pulsed RF tests																			
8.1.10	<b>Evaluation of tuner operation</b>																			
<b>8.2</b>	<b>Magneto-strictive Tuner</b>																			
8.2.1	Complete specification																			
8.2.2	Conceptual design																			
8.2.3	Prototype and performance evaluation																			
8.2.4	Finalize tuner and drive electronics design																			
8.2.5	Test of tuner																			
8.2.6	<b>Report on magneto-strictive Tuner</b>																			
<b>8.3</b>	<b>CEA Tuner</b>																			
8.3.1	Design Piezo + Tuning System																			
8.3.2	Fabrication																			
8.3.3	Installation RF																			
8.3.4	<b>Start of Integrated Experiments</b>																			
<b>8.4</b>	<b>IN2P3 Activity</b>																			
8.4.1	Characterize actuators/piezo-sensors at low temperat.																			
8.4.2	Report on actuator/piezo sensor																			
8.4.3	Test radiation hardness of piezo tuners																			
8.4.4	Report on radiation hardness tests																			
8.4.5	Integration of piezo and cold tuner																			
8.4.6	Cryostat tests																			
8.4.7	Tests with pulsed RF																			
8.4.8	<b>Report on IN2P3 tuner activities</b>																			

D. DETAILED IMPLEMENTATION PLAN FOR THE NEXT 18 MONTHS

N°	Task Name	2006												2007						
		Jan	Feb	Mrz	Apr	Mai	Jun	Jul	Aug	Sep	Okt	Nov	Dez	Jan	Feb	Mrz	Apr	Mai	Jun	Jul
<b>9</b>	<b>WP9 LOW LEVEL RF (LLRF)</b>																			
<b>9.1</b>	<b>Operability and technical performance</b>																			
<b>9.1.1</b>	<b>Transient detector</b>																			
9.1.1.1	Define requirements																			
9.1.1.2	Electronics design																			
9.1.1.3	Build prototype and evaluate																			
9.1.1.4	Final design of detector																			
9.1.1.5	Installation and commissioning																			
9.1.1.6	Test with beam																			
9.1.1.7	<b>Report on transient detector test</b>	◆ 08.12.																		
<b>9.1.2</b>	<b>LLRF Automation</b>																			
9.1.2.1	Dialogue with industrial experts																			
9.1.2.2	Develop full specification																			
9.1.2.3	Implement FMS for subsystems																			
9.1.2.4	Test and evaluation																			
9.1.2.5	Implement improvements																			
9.1.2.6	Evaluation and acceptance by operators																			
9.1.2.7	<b>Report on LLRF atomization design</b>	◆ 23.06.																		
<b>9.1.3</b>	<b>Control optimization</b>																			
9.1.3.1	Specification of system																			
9.1.3.2	Conceptual design of controller																			
9.1.3.3	Performance simulation																			
9.1.3.4	Implementation in DSP hardware																			
9.1.3.5	Implementation and tests on TTF																			
9.1.3.6	<b>Evaluation of test results</b>	◆ 13.10.																		
<b>9.1.4</b>	<b>Exceptional handling routines</b>																			
9.1.4.1	Specification																			
9.1.4.2	Design of exceptional handler																			
9.1.4.3	Implementation and test on TTF																			
9.1.4.4	<b>Report on exceptional handler operation</b>	2.																		
<b>9.2</b>	<b>LLRF cost and reliability study</b>																			
<b>9.2.1</b>	<b>Cost and reliability study</b>																			
9.2.1.1	Identify cost drivers of present LLRF																			
9.2.1.2	Develop cost reduction ideas																			
9.2.1.3	Build prototypes and evaluate																			
9.2.1.4	Final design of LLRF system																			
9.2.1.5	<b>Complete design of LLRF system for reduce cost</b>	◆ 29.09.																		
<b>9.2.2</b>	<b>Radiation damage study</b>																			
9.2.2.1	Identify critical electronics issues																			
9.2.2.2	Evaluate TESLA radiation																			
9.2.2.3	Develop tests for components																			
9.2.2.4	Procure and assemble test set up																			
9.2.2.5	Data acquisition from radiation tests																			
9.2.2.6	Analyze results and develop countermeasures																			
9.2.2.7	Implement countermeasures and verify																			
9.2.2.8	<b>Report on radiation damage studies</b>	◆ 27.10.																		
<b>9.3</b>	<b>Hardware</b>																			
<b>9.3.1</b>	<b>Multichannel downconverter</b>																			
9.3.1.1	Study and compare technologies																			
9.3.1.2	Select optimum PCB design																			
9.3.1.3	Build prototype and evaluate																			
9.3.1.4	Finalize multichannel downconverter																			
9.3.1.5	Determine characteristics																			
<b>9.3.2</b>	<b>Third generation RF control</b>																			
9.3.2.1	Integrate system generator with VHDL																			
9.3.2.2	Complete specification																			
9.3.2.3	Demonstrate simulator																			
9.3.2.4	Final design of RF electronic board																			
9.3.2.5	Evaluate performance																			
<b>9.3.3</b>	<b>Stable frequency distribution</b>																			
9.3.3.1	Complete specification																			
9.3.3.2	Conceptual design of frequency																			
9.3.3.3	Build prototype and evaluate																			
9.3.3.4	Final design																			
9.3.3.5	Procurement and assembly of subsystems																			
9.3.3.6	Installation and commissioning																			
9.3.3.7	Performance test with beam																			
9.3.3.8	<b>Report on new LLRF hardware components</b>	◆ 01.03.																		

D. DETAILED IMPLEMENTATION PLAN FOR THE NEXT 18 MONTHS

N°	Task Name	2006												2007						
		Jan	Feb	Mrz	Apr	Mai	Jun	Jul	Aug	Sep	Okt	Nov	Dez	Jan	Feb	Mrz	Apr	Mai	Jun	Jul
<b>9.4</b>	<b>Software</b>	[Bar chart showing software development tasks from Jan 2006 to Oct 2006]																		
<b>9.4.1</b>	<b>Data management development</b>	[Bar chart showing data management development tasks from Jan 2006 to Oct 2006]																		
9.4.1.1	Specification																			
9.4.1.2	Conceptional design w ith DOOCS																			
9.4.1.3	Prototype																			
9.4.1.4	User evaluation																			
9.4.1.5	Finalize design																			
9.4.1.6	Implementation in TTF																			
9.4.1.7	<b>Report on data management developments</b>																			
<b>9.4.2</b>	<b>RF gun control</b>	[Bar chart showing RF gun control tasks from Jan 2006 to Oct 2006]																		
9.4.2.1	Write specification																			
9.4.2.2	Design of controller																			
9.4.2.3	Procurement and assembly																			
9.4.2.4	Installation and test																			
9.4.2.5	<b>Report on RF gun control tests</b>	06.10.																		

N°	Task Name	2006												2007						
		Jan	Feb	Mrz	Apr	Mai	Jun	Jul	Aug	Sep	Okt	Nov	Dez	Jan	Feb	Mrz	Apr	Mai	Jun	Jul
<b>10</b>	<b>WP10 CRYOSTAT INTEGRATION TESTS</b>	[Bar chart showing cryostat integration tests from Jan 2006 to Jul 2007]																		
10.1	Displace CRYHOLAB																			
<b>10.2</b>	<b>CRYHOLAB adaption to 9 cell</b>	[Bar chart showing cryostat adaption tasks from Jan 2006 to Jul 2007]																		
10.2.1	Mechanical adaption																			
10.2.2	Low performance cavity and coupler																			
10.2.3	Assembly in CRYHOLAB and cryogenic test																			
10.2.4	High performance coupler - High power pulsed test																			
10.2.5	Magnetic shielding with cryoperm																			
<b>10.3</b>	<b>Integration tests in cryostat (1st test)</b>	[Bar chart showing 1st integration test from Jan 2006 to Oct 2006]																		
10.3.1	CEA Cold Tuning System + Pezo (Assembly + warm te																			
10.3.2	Installation of 9-cell & coupler - Cooldown n																			
10.3.3	Cold test in CryHoLab																			
10.3.4	Evaluate experimental results																			
<b>10.4</b>	<b>Integration tests in cryostat (2nd test)</b>	[Bar chart showing 2nd integration test from Sep 2006 to Nov 2006]																		
10.4.1	Magnetostrictive tuner																			
10.4.2	Evaluate experimental results																			
<b>10.5</b>	<b>Integration tests in cryostat (3rd test)</b>	[Bar chart showing 3rd integration test from Oct 2006 to Dec 2006]																		
10.5.1	Piezoelectric tuner																			
10.5.2	Evaluate experimental results																			
<b>10.6</b>	<b>Integration tests in cryostat (4th test)</b>	[Bar chart showing 4th integration test from Jan 2007 to Apr 2007]																		
10.6.1	New coupler from LAL																			
10.6.2	Evaluation of results																			
10.6.3	<b>Final evaluation</b>	04.04.																		

N°	Task Name	2006												2007						
		Jan	Feb	Mrz	Apr	Mai	Jun	Jul	Aug	Sep	Okt	Nov	Dez	Jan	Feb	Mrz	Apr	Mai	Jun	Jul
<b>11</b>	<b>WP 11 BEAM DIAGNOSTICS</b>	[Bar chart showing beam diagnostics tasks from Jan 2006 to Jul 2007]																		
<b>11.1</b>	<b>Beam position monitor</b>	[Bar chart showing beam position monitor tasks from Jan 2006 to Jul 2007]																		
11.1.1	Present BPM installed in TTF module																			
11.1.2	Cryogenic measurements on BPM																			
11.1.3	Beam tests of BPM on TTF																			
11.1.4	Design of BPM Cavity																			
11.1.5	Design of BPM cavity ready																			
11.1.6	Fabrication of BPM Cavity																			
11.1.7	BMP cavity ready	23.12.																		
11.1.8	Development of new hybrid coupler and electronics																			
11.1.9	Design of Digital Signal Processing																			
11.1.10	<b>New BPM ready for Installation</b>	01.01.																		
11.1.11	Beam Tests with new BPM																			
11.1.12	<b>Evaluation of BPM operation</b>																			
<b>11.2</b>	<b>Beam Emittance Monitor</b>	[Bar chart showing beam emittance monitor tasks from Jan 2006 to Jul 2007]																		
11.2.1	Slt width simulations																			
11.2.2	Slt design																			
11.2.3	Optics simulations																			
11.2.4	Optics appropriations																			
11.2.5	System assembly and tests																			
11.2.6	Mechanical assembly at TTF																			
11.2.7	Optical assembly at TTF																			
11.2.8	Integration of controls into TTF																			
11.2.9	<b>Ready for beam test in TTF</b>	31.12.																		
11.2.10	Beam tests at TTF																			
11.2.11	Evaluate first beam test result																			
11.2.12	Successive measurements																			
11.2.13	<b>Final evaluation</b>	02.06.																		

JRA2: Charge Production in Photo-Injector (PHIN)

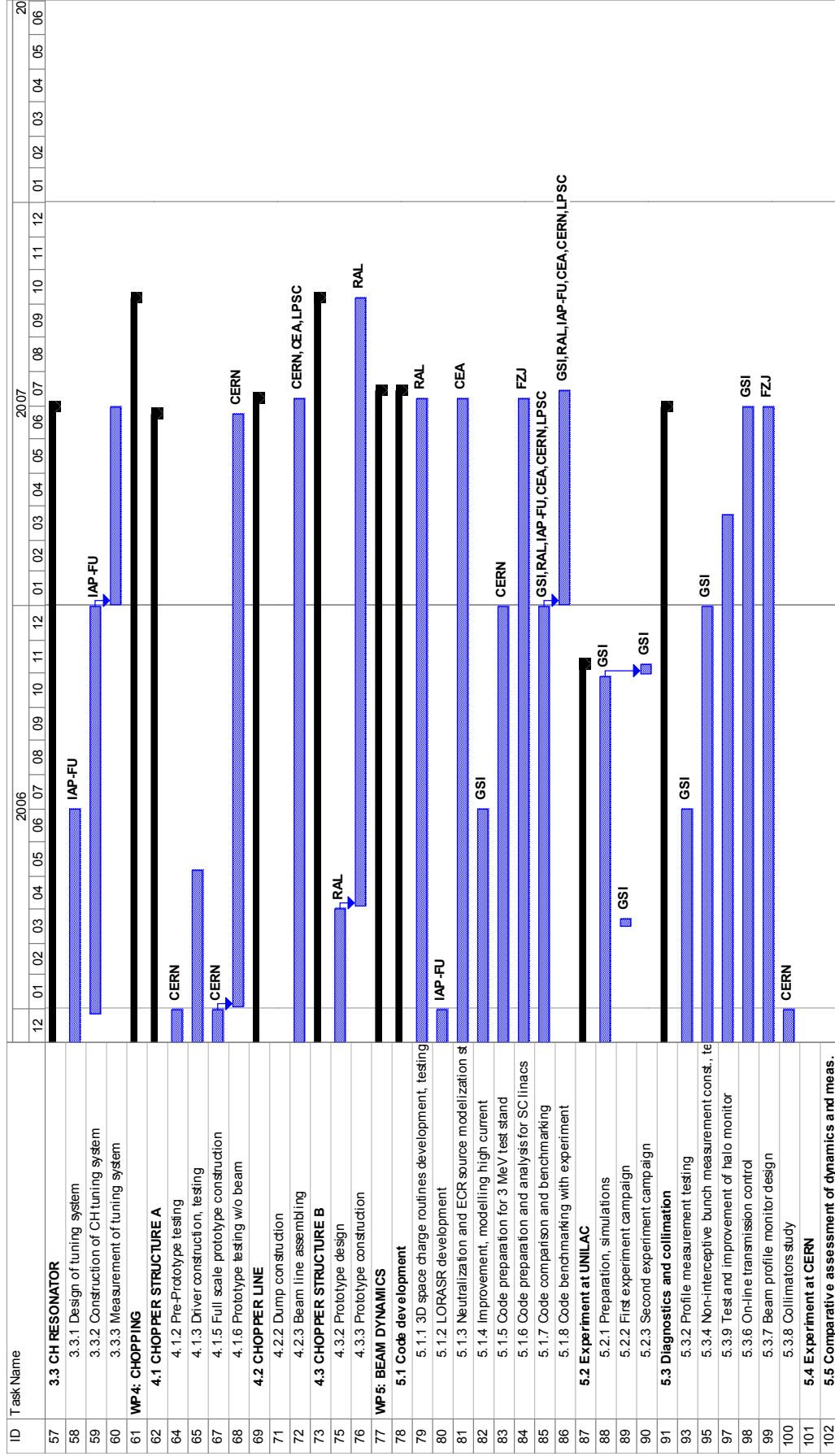
Task Name	Milestones	Main Deliverables	2006	2007
			12 1 2 3 4 5 6 7 8 9 10 11 12	1 2 3 4 5 6 7 8
<b>WP2 Charge Production</b>				
<b>High efficiency photocathode for 3 GHz RF gun</b>		<b>Final report</b>		
High efficiency photocathode comparison		<b>Photocathode ready</b>		
photocathode 3 GHz high field R&D			3/31	6/30
<b>Photocathode for SC cavity</b>		<b>Final Report</b>		
Photocathodes test				
<b>Laser driven plasma source</b>				
250 MeV laser driven plasma source R&D	Inter.Report			
<b>WP3 Laser</b>				
<b>Laser System</b>		<b>Final report</b>		
Oscillator + amplifier test			3/31	
<b>Pulse shaping system</b>		<b>Pulse shaper ready</b>		
Pulse shaping comparison				
<b>UV generation and Feedbacks</b>		<b>UV crystals ready</b>		
UV Harmonic generator test		<b>Feedback test</b>	4/28	
Laser-RF Feedback development		<b>Laser System ready</b>		8/25
Overall system assembly and tests				
<b>WP4 GUN</b>				
<b>SC RF gun</b>		<b>SC RF gun ready</b>		
SC RF gun realisation		<b>Final Report</b>	3/31	
SC RF gun test				
<b>3 GHz RF gun</b>		<b>3 GHz RF guns ready</b>		
Two 3 GHz RF guns construction		<b>Final report</b>	8/15	
CTF3 3GHz RF gun test at CERN		<b>Final report</b>		6/23
NEPAL 3 GHz RF gun testat Orsay				
<b>Spectrometer for e- beam</b>		<b>Spectrometer ready</b>		
1-250 MeV Spectrometer construction		<b>Final report</b>		
1-250 MeV Spectrometer test				
0.1-1Gev Spectrometer development	Inter. Report			

**JRA3: High Intensity Proton injector (HIPPI)**

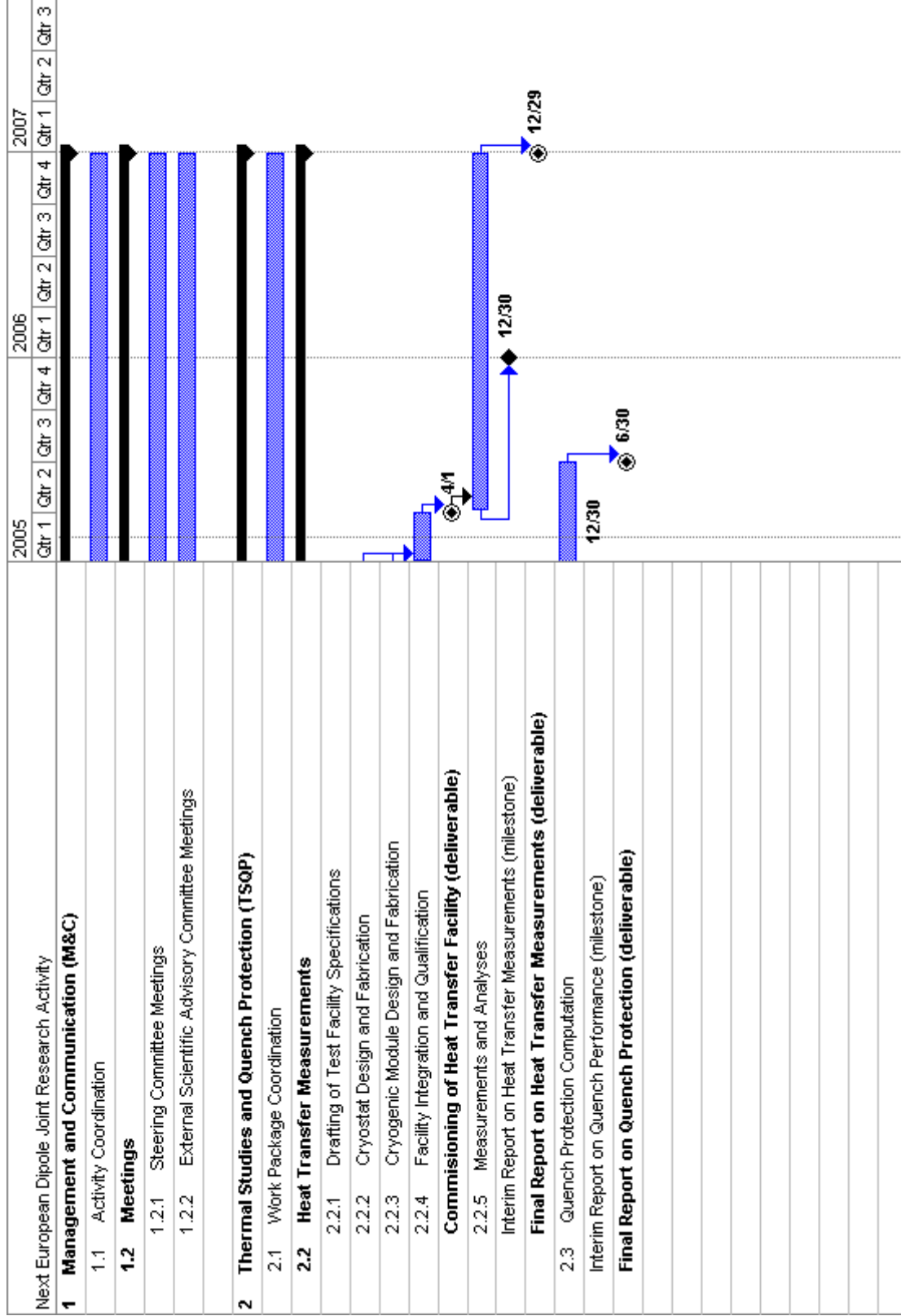
ID	Task Name	2006	2007	2008	2009	2010	2011	2012	2013	2014	2015	2016	2017
1	<b>WP2: NORMAL CONDUCTING STRUCTURES</b>												
2	2.1 Drift Tube Linac												
3	2.1.1 DTL design												
6	2.1.5 DTL coupler prototype construction and testing												
7	2.1.4 DTL beam dynamics design												
8	2.2 H-mode Drift Tube Linac												
9	2.2.1 RF model CH tank1 RF design												
10	2.2.2 RF cold model design & construction												
11	2.2.3 RF model construction												
13	2.2.5 CH model cavity tests												
15	2.2.7 CH-prototype construction, tests												
17	2.3 Side Coupled Linac												
18	2.3.1 RF model RF design												
19	2.3.2 RF model mechanical design												
20	2.3.3 RF model construction												
21	2.3.4 RF model testing												
22	2.3.5 SCL module design												
23	2.4 Cell Coupled Drift Tube Linac												
25	2.4.2 Pre-prototype high-power RF tests												
27	2.4.4 Revision of design after prototype testing												
28	2.4.5 Testing of ISTC prototype												
29	<b>WP3: SUPERCONDUCTING STRUCTURES</b>												
30	3.1 ELLIPTICAL CAVITIES												
32	3.1.2 Tuner design												
33	3.1.3 Integration of piezo design												
34	3.1.4 Tuner construction												
35	3.1.13 Cavity A assembly with tuner												
37	3.1.6 Construction cavity B												
38	3.1.13 Preparation, vert. test & welding cavity B												
39	3.1.7 Power coupler design & engineering												
40	3.1.9 RF couplers construction & preparation												
41	3.1.8 RF source order & construction												
42	3.1.10 Modulator preparation for 700 MHz test stand												
43	3.1.11 RF source testing												
44	3.1.12 High power pulsed tests												
45	3.2 SPOKE CAVITIES												
47	3.2.2 Evaluation of 760 MHz resonator in vertical cry												
49	3.2.4 Design of coupler prototype												
50	3.2.5 Construction of coupler prototype												
51	3.2.9 Test of coupler prototype												
54	3.2.8 Final design of 352 MHz multi-gap prototype												
55	3.2.10 Manufacturing of 352MHz multi-gap prototype												



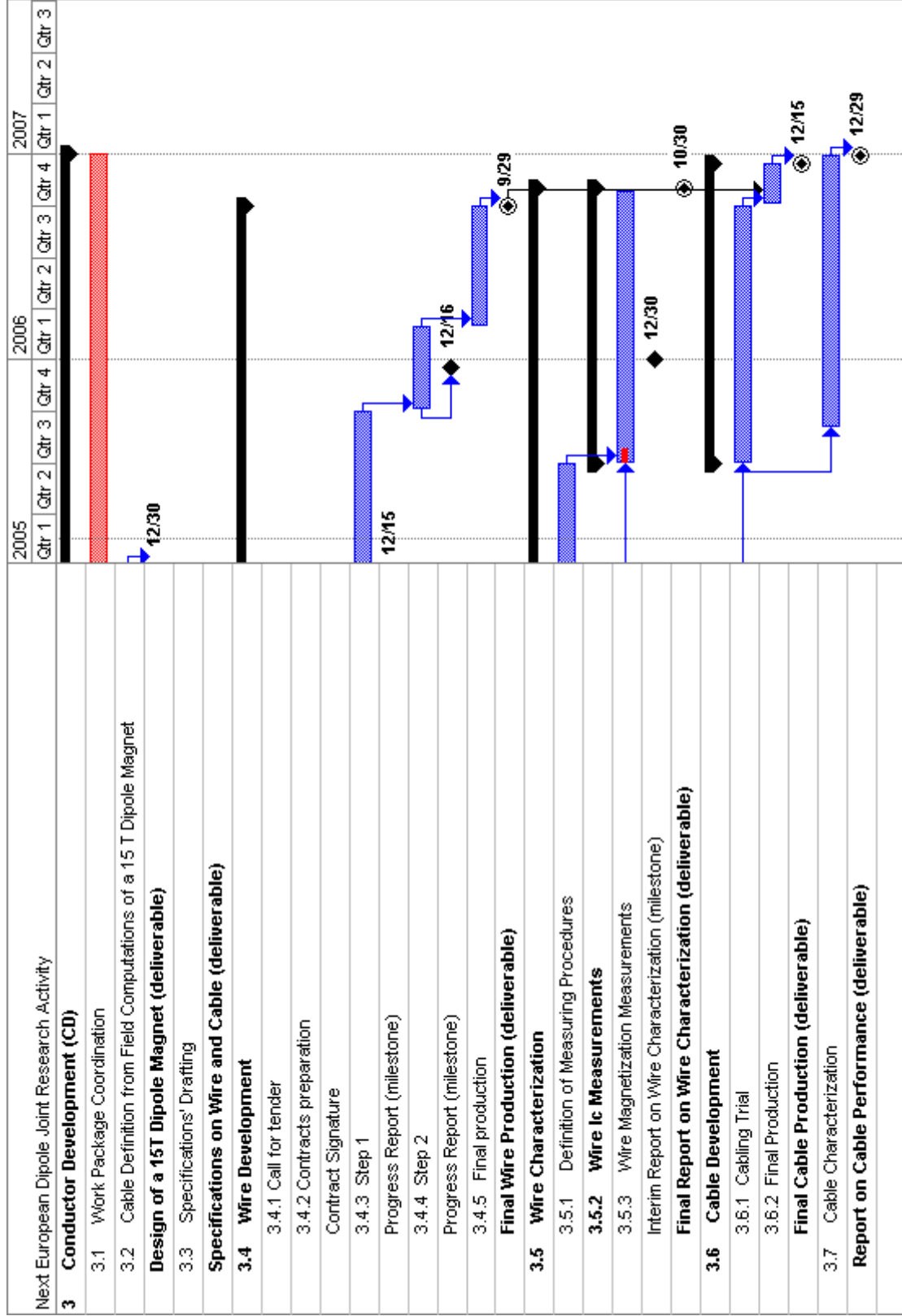
D. DETAILED IMPLEMENTATION PLAN FOR THE NEXT 18 MONTHS



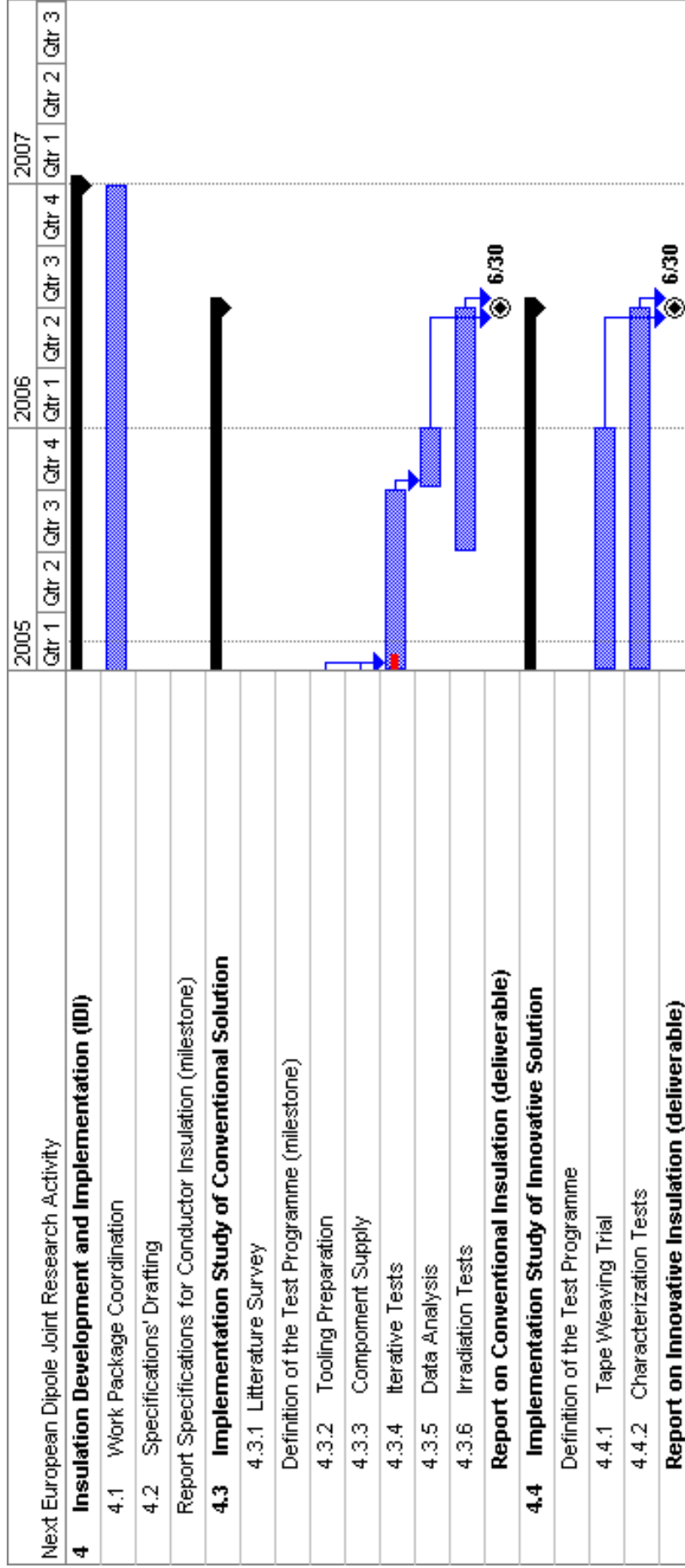
### JRA4: New European Dipole (NED)



D. DETAILED IMPLEMENTATION PLAN FOR THE NEXT 18 MONTHS



D. DETAILED IMPLEMENTATION PLAN FOR THE NEXT 18 MONTHS



**Financial information for the duration of the detailed implementation plan (per activity)**

**N0 Management**

	Participant (cost model)	Permanent Staff direct cost ONLY (Euros)	Eligible Staff direct cost ONLY (Euros)	Durable Equipment direct cost ONLY (Euros)	Consumables and Prototyping direct cost ONLY (Euros)	Travel including direct cost ONLY (Euros)	All Direct cost	Subcontract	Indirect cost	Expected costs including indirect cost (Euros)	Requested funding (Euros)
1	CEA(FC)	233 250	0	1 500	7 500	11 100	253 350	0	194 250	447 600	187 260
	<b>Grand total</b>	<b>233 250</b>	<b>0</b>	<b>1 500</b>	<b>7 500</b>	<b>11 100</b>	<b>253 350</b>	<b>0</b>	<b>194 250</b>	<b>447 600</b>	<b>187 260</b>

**N1 Electron Linear Accelerator Network (ELAN)**

N1	Participant (cost model)	Permanent Staff direct cost ONLY (Euros)	Eligible Staff direct cost ONLY (Euros)	Durable Equipment direct cost ONLY (Euros)	Consumables and Prototyping direct cost ONLY (Euros)	Travel including direct cost ONLY (Euros)	All Direct cost	Subcontract	Indirect cost	Expected costs including indirect cost (Euros)	Requested funding (Euros)
1	CEA(FC)	0	0	0	0	7 500	7 500	0	0	7 500	7 500
3	CNRS(FCF)	0	0	0	0	39 167	39 167	0	7 833	47 000	47 000
6	DESY(AC)	0	0	0	0	59 167	59 167	0	11 833	71 000	71 000
7	FZJ(FC)	0	0	0	0	2 000	2 000	0	0	2 000	2 000
9	FZR(AC)	0	0	0	0	5 000	5 000	0	1 000	6 000	6 000
10	INFN(AC)	0	0	0	0	22 500	22 500	0	4 500	27 000	27 000
11	TEU(FC)	0	0	0	0	2 200	2 200	0	0	2 200	2 200
12	TUL(AC)	0	0	0	0	2 750	2 750	0	550	3 300	3 300
13	IPJ(AC)	0	0	0	0	2 750	2 750	0	550	3 300	3 300
14	WUT-ISE(AC)	0	0	0	0	2 750	2 750	0	550	3 300	3 300
16	CSIC(FC)	0	0	0	0	3 400	3 400	0	0	3 400	3 400
17	CERN(AC)	0	0	0	0	33 333	33 333	0	6 667	40 000	40 000
19	PSI(FC)	0	0	0	0	3 000	3 000	0	0	3 000	0
20	CCLRC(FC)	0	0	0	0	13 500	13 500	0	0	13 500	13 500
21	ICL(AC)	0	0	0	0	4 667	4 667	0	933	5 600	5 600
22	UMA(AC)	0	0	0	0	12 167	12 167	0	2 433	14 600	14 600
	<b>Grand total</b>	<b>0</b>	<b>0</b>	<b>0</b>	<b>0</b>	<b>215 851</b>	<b>215 851</b>	<b>0</b>	<b>36 849</b>	<b>252 700</b>	<b>249 700</b>

**N2 Beam in Europe for Neutrino Experiments (BENE)**

N2	Participant (cost model)	Permanent Staff direct cost ONLY (Euros)	Eligible Staff direct cost ONLY (Euros)	Durable Equipment direct cost ONLY (Euros)	Consumables and Prototyping direct cost ONLY (Euros)	Travel direct cost ONLY (Euros)	All direct Cost	Subcontract	Indirect cost	Expected costs including indirect cost (Euros)	Requested funding (Euros)
1	CEA(FC)	0	0	0	0	14 250	14 250	0	0	14 250	14 250
2	UCLN(AC)	0	0	0	0	2 000	2 000	0	400	2 400	2 400
3	CNRS(FCF)	0	0	0	0	11 396	11 396	0	2 279	13 675	13 675
4	GSI(FC)	0	0	0	0	3 090	3 090	0	0	3 090	3 090
7	FZJ(FC)	0	0	0	0	9 900	9 900	0	0	9 900	9 900
8	TUM(AC)	0	0	0	0	2 583	2 583	0	517	3 100	3 100
10	INFN(AC)	0	0	0	0	23 250	23 250	0	4 650	27 900	27 900
16	CSIC(FC)	0	0	0	0	11 100	11 100	0	0	11 100	11 100
17	CERN (AC)	0	0	0	0	10 000	10 000	0	2 000	12 000	12 000
18	UNI-GE(AC)	0	0	0	0	23 914	23 914	0	3 986	27 900	0
19	PSI(FC)	0	0	0	0	5 220	5 220	0	0	5 220	0
20	CCLRC(FC)	0	0	0	0	13 000	13 000	0	0	13 000	13 000
21	ICL(AC)	0	0	0	0	25 000	25 000	0	5 000	30 000	30 000
	<b>Grand total</b>	<b>0</b>	<b>0</b>	<b>0</b>	<b>0</b>	<b>154 703</b>	<b>154 703</b>	<b>0</b>	<b>18 832</b>	<b>173 535</b>	<b>140 415</b>



**N3 High-Energy High-Intensity Hadron Beams (HHH)**

<b>N3</b>	<b>Participant (cost model)</b>	<b>Permanent Staff direct cost ONLY (Euros)</b>	<b>Additional Staff direct cost ONLY (Euros)</b>	<b>Durable Equipment direct cost ONLY (Euros)</b>	<b>Consumables and Prototyping direct cost ONLY (Euros)</b>	<b>Travel direct cost ONLY (Euros)</b>	<b>All Direct cost</b>	<b>Subcontract</b>	<b>Indirect cost</b>	<b>Expected costs including indirect cost (Euros)</b>	<b>Requested funding (Euros)</b>
1	CEA(FC)	0	0	0	0	5 250	5 250	0	0	5 250	5 250
4	GSI(FC)	0	0	0	0	4 950	4 950	0	0	4 950	4 950
6	DESY(AC)	0	0	0	0	4 717	4 717	0	943	5 660	5 660
10	INFN(AC)	0	0	0	0	12 000	12 000	0	2 400	14 400	14 400
11	TEU(FC)	0	0	0	0	0	0	0	0	0	0
15	WUT(AC)	0	0	0	0	0	0	0	0	0	0
16	CSIC(FC)	0	0	0	0	1 000	1 000	0		1 000	1 000
17	CERN(AC)	0	50 000	0	0	42 970	92 970	0	18 594	111 564	111 564
19	PSI(FC)	0	0	0	0	0	0	0	0	0	0
20	CCLRC(FC)	0	0	0	0	1 050	1 050	0	0	1 050	1 050
	<b>Grand total</b>	<b>0</b>	<b>50 000</b>	<b>0</b>	<b>0</b>	<b>71 937</b>	<b>121 937</b>	<b>0</b>	<b>21 937</b>	<b>143 874</b>	<b>143 874</b>

**JRA1 Superconducting Radio-Frequency (SRF)**

JRA1	Participant (cost model)	Permanent Staff direct cost ONLY (Euros)	Additional Staff direct cost ONLY (Euros)	Durable Equipment direct cost ONLY (Euros)	Consumables and Prototyping direct cost ONLY (Euros)	Travel direct cost ONLY (Euros)	All Direct Cost	Subcontract	Indirect cost	Expected costs including indirect cost (Euros)	Requested funding (Euros)
1	CEA(FC)	330 033	160 000	0	100 000	15 000	605 033	0	360 836	965 869	138 450
3	CNRS(FCF)	434 375	38 128	33 420	83 615	4 167	593 705	0	118 741	712 446	148 700
6	DESY(AC)	0	300 000	0	190 333	28 000	518 333	110 000	81 667	600 000	600 000
	INFN-LNL	0	80 000	0	0	5 000	85 000	0	17 000	102 000	102 000
	INFN-LNF	0	50 000	0	16 667	20 000	86 667	0	17 333	104 000	104 000
	INFN-Mi	0	41 585	0	23 537	4 670	69 792	0	13 958	83 750	83 750
	INFN-Ro2	0	45 970	3 600	16 350	6 788	72 708	0	14 542	87 250	87 250
10	INFN(AC)	0	217 555	3 600	56 554	36 458	314 167	0	62 833	377 000	377 000
12	TUL(AC)	0	18 000	0	27 750	6 960	52 710	0	10 542	63 252	63 252
13	IPJ(AC)	0	19 750	3 333	16 667	12 500	52 250	0	10 450	62 700	50 000
14	WUT-ISE(AC)	0	24 167	0	47 167	7 833	79 167	0	15 833	95 000	95 000
19	PSI(FC)	30 637	31 104	0	0	8 320	70 061	0	17 516	87 577	0
	<b>Grand total</b>	<b>795 045</b>	<b>808 704</b>	<b>40 353</b>	<b>522 085</b>	<b>119 238</b>	<b>2 285 426</b>	<b>110 000</b>	<b>678 418</b>	<b>2 963 843</b>	<b>1 472 401</b>

**JRA2 Charge Production with Photo-Injectors (PHIN)**

JRA2	Participant (cost model)	Permanent Staff direct cost ONLY (Euros)	Additional Staff direct cost ONLY (Euros)	Durable Equipment direct cost ONLY (Euros)	Consumables and Prototyping direct cost ONLY (Euros)	Travel direct cost ONLY (Euros)	All Direct Cost	Subcontract	Indirect cost	Expected costs including indirect cost (Euros)	Requested funding (Euros)
	CNRS-Orsay	384 375	35 000	90 000	10 000	5 000	524 375	0	104 875	629 250	175000
	CNRS-LOA	120 000	60 000	0	112 000	10 000	302 000	0	60 400	362 400	105000
3	CNRS(FCF)	504 375	95 000	90 000	122 000	15 000	826 375	0	165 275	991 650	280000
9	FZR(AC)	0	75 000	0	50 000	7 500	132 500	0	26 500	159 000	132500
	INFN-LNF	0	80 000	0	33 000	10 000	123 000	0	24 600	147 600	123000
	INFN-MI	0	80 000	0	25 000	6 600	111 600	0	22 320	133 920	111600
10	INFN(AC)	0	160 000	0	58 000	16 600	234 600	0	46 920	281 520	234600
11	TEU(FC)	35 910	167 580	0	45 000	5 000	253 490	0	50 600	304 090	101773
17	CERN (AC)	0	42 500	0	526 000	18 400	586 900	0	117 380	704 280	586 900
20	CCLRC (FC)	13 719	28 843	0	0	6 620	49 182	0	59582	108 764	11000
	<b>Grand total</b>	<b>554 004</b>	<b>568 923</b>	<b>90 000</b>	<b>801 000</b>	<b>69 120</b>	<b>2 083 047</b>	<b>0</b>	<b>466 257</b>	<b>2 549 304</b>	<b>1 346 773</b>

**JRA3 High Intensity Pulsed Proton Injectors (HIPPI)**

JRA3	Participant (cost model)	Permanent Staff direct cost ONLY (Euros)	Additional Staff direct cost ONLY (Euros)	Durable Equipment direct cost ONLY (Euros)	Consumables and Prototyping direct cost ONLY (Euros)	Travel direct cost ONLY (Euros)	All Direct Cost	Subcontract	Indirect cost	Expected costs including indirect cost (Euros)	Requested funding (Euros)
1	CEA (FC)	384 637	100 000	450 000	280 000	4 000	1 218 637	0	357 853	1 576 490	504 000
3	CNRS-IPNO	80 000	18 000	0	35 000	4 000	137 000	0	27 400	164 400	30 000
	CNRS-LPSC	96 000	0	0	40 000	3 000	139 000	0	27 800	166 800	24 000
	CNRS(FCF)	176 000	18 000	0	75 000	7 000	276 000	0	55 200	331 200	54 000
4	GSI(FC)	147 570	174 258	10 000	2 900	7 800	342 528	0	78 000	420 528	236 550
5	IAP-FU(AC)	0	185 000	0	310 000	13 333	508 333	0	101 667	610 000	245 000
7	FZJ(FC)	204 000	110 000	0	75 000	9 000	398 000	0	293 088	691 088	194 000
10	INFN-Mi(AC)	0	0	0	20 000	5 000	25 000	0	5 000	30 000	15 000
17	CERN (AC)	0	280 000	20 000	40 000	12 000	352 000	0	70 400	422 400	100 000
20	CCLRC (FC)	202 252	125 470	0	220 650	5 000	553 372	0	458 811	1 012 183	140 795
	<b>Grand total</b>	<b>1 114 459</b>	<b>992 728</b>	<b>480 000</b>	<b>1 023 550</b>	<b>63 133</b>	<b>3 673 870</b>	<b>0</b>	<b>1 420 019</b>	<b>5 093 889</b>	<b>1 489 345</b>

**JRA4 Next European Dipole (NED)**

JRA4	Participant (cost model)	Permanent Staff direct cost ONLY (Euros)	Eligible Staff direct cost ONLY (Euros)	Durable Equipment direct cost ONLY (Euros)	Consumables and Prototyping direct cost ONLY (Euros)	Travel direct cost ONLY (Euros)	All direct Cost	Subcontract	Indirect cost	Expected costs including indirect cost (Euros)	Requested funding (Euros)
1	CEA (FC)	98 857	96 642	0	37 500	20 000	252 999	0	152 668	405 667	31 755
10	INFN (AC)	0	7 000	0	15 700	4 000	26 700	0	5 340	32 040	32 000
11	TEU (FC)	62 563	0	0	15 000	3 000	80 563	0	56 817	137 380	54 700
15	WUT (AC)	0	0	0	0	6 042	6 042	0	1 208	7 250	7 250
17	CERN (AC)	0	0	0	465 000	0	465 000	465 000	0	465 000	465 000
20	CCLRC (FC)	99 000	0	0	9 300	5 300	113 600	0	57 717	171 317	24 012
	<b>Grand total</b>	<b>260 420</b>	<b>103 642</b>	<b>0</b>	<b>542 500</b>	<b>38 342</b>	<b>944 904</b>	<b>465 000</b>	<b>273 750</b>	<b>1 218 654</b>	<b>614 717</b>

**Financial information for the duration of the detailed implementation plan (per contractor)**

Proposal Number <sup>1</sup>	506395	Proposal Acronym <sup>2</sup>	CARE
------------------------------	--------	-------------------------------	------

Participant n° <i>Erreur ! Source du renvoi introuvable.</i>	Organization short name	Cost model used		Estimated eligible costs and requested EC contribution (first 18 months of the project)	RTD <i>Erreur ! Source du renvoi introuvable.</i> activities (1)	Demonstration activities <i>Erreur ! Source du renvoi introuvable.</i> (2)	Consortium Management activities <i>Erreur ! Source du renvoi introuvable.</i> (3)	Other specific activities <i>Erreur ! Source du renvoi introuvable.</i>				Total receipts <i>Erreur ! Source du renvoi introuvable.</i>
		For transnational Access <i>Erreur ! Source du renvoi introuvable.</i>	For any other activities <i>Erreur ! Source du renvoi introuvable.</i>					Coordinating <i>Erreur ! Source du renvoi introuvable.</i> (4)	Transnational access <i>Erreur ! Source du renvoi introuvable.</i> (5)	Connectivity <i>Erreur ! Source du renvoi introuvable.</i> (6)	Other including Specific Service Activities for CND <i>Erreur ! Source du renvoi introuvable.</i> (7)	
1	CEA	FC		Direct costs (a)	2 076 670		253 350	27 000				2 357 020
				Eligible costs	0		0					0
				Indirect costs (b)	871 356		194 250	0				
Requested EC contribution				Total eligible costs (a)+(b)	2 948 026		447 600	27 000				3 422 626
2	UCLN	AC		Direct costs (a)	0			2 000				2 000
				Eligible costs	0							0
				Indirect costs (b)	0			400				
Requested EC contribution				Total eligible costs (a)+(b)	0			2 400				2 400
3	CNRS	FCF		Direct costs (a)	1 696 080			50 563				1 746 643
				Eligible costs	0			0				0
				Indirect costs (b)	339 216			10 113				
Requested EC contribution				Total eligible costs (a)+(b)	2 035 296		60 676	60 676				2 095 972
4	GSI	FC		Direct costs (a)	342 528			8 040				350 568
				Eligible costs	0			0				0
				Indirect costs (b)	78 000			0				
Requested EC contribution				Total eligible costs (a)+(b)	420 528		8 040	8 040				428 568
Requested EC contribution				Eligible costs	236 550							244 590
Requested EC contribution				Requested EC contribution								
TOTAL <i>Erreur ! Source du renvoi introuvable.</i>												

Proposal Number <sup>1</sup>	506395	Proposal Acronym <sup>2</sup>	CARE
------------------------------	--------	-------------------------------	------

**Financial Information – “Reporting period 2 + first six months of Reporting period 3”**

Participant n° <i>Erreur ! Source du renvoi introuvable.</i>	Organization short name	Cost model used		Estimated eligible costs and requested EC contribution (first 18 months of the project)	RTD <i>Erreur ! Source du renvoi introuvable.</i> activities (1)	Demonstration activities <i>Erreur ! Source du renvoi introuvable.</i> (2)	Consortium Management activities <i>Erreur ! Source du renvoi introuvable.</i> (3)	Other specific activities <i>Erreur ! Source du renvoi introuvable.</i>				Total receipts <i>Erreur ! Source du renvoi introuvable.</i>		
		For transnational Access <i>Erreur ! Source du renvoi introuvable.</i>	For any other activities <i>Erreur ! Source du renvoi introuvable.</i>					Coordinating <i>Erreur ! Source du renvoi introuvable.</i> (4)	Transnational access <i>Erreur ! Source du renvoi introuvable.</i> (5)	Connectivity <i>Erreur ! Source du renvoi introuvable.</i> (6)	Other including Specific Service Activities for CND <i>Erreur ! Source du renvoi introuvable.</i> (7)		Total (8)= (1)+(2)+(3)+ (4)+(5)+(6)+ (7)	
5	IAP-FU	AC		Direct costs (a)	508 333							508 333		
				Eligible costs	0								0	
				Indirect costs (b)	101 667									101 667
				Total eligible costs (a)+(b)	610 000							610 000		
				Requested EC contribution	245 000							245 000		
6	DESY	AC		Direct costs (a)	518 333								518 333	
				Eligible costs	110 000									110 000
				Indirect costs (b)	81 667									81 667
				Total eligible costs (a)+(b)	600 000									600 000
				Requested EC contribution	600 000									
7	FZJ	FC		Direct costs (a)	398 000								398 000	
				Eligible costs	0									0
				Indirect costs (b)	293 088									293 088
				Total eligible costs (a)+(b)	691 088									691 088
				Requested EC contribution	194 000									
8	TUM	AC		Direct costs (a)	0								0	
				Eligible costs	0									0
				Indirect costs (b)	517									517
				Total eligible costs (a)+(b)	3 100									3 100
				Requested EC contribution	3 100									
<b>TOTAL</b> <i>Erreur ! Source du renvoi introuvable.</i>				Eligible costs										
				Requested EC contribution										



Proposal Number <sup>1</sup>	506395	Proposal Acronym <sup>2</sup>	CARE
------------------------------	--------	-------------------------------	------

**Financial Information – “Reporting period 2 + first six months of Reporting period 3”**

Participant n° <i>Erreur ! Source du renvoi introuvable.</i>	Organization short name	Cost model used		Estimated eligible costs and requested EC contribution (first 18 months of the project)	RTD <i>Erreur ! Source du renvoi introuvable.</i> activities (1)	Demonstration activities <i>Erreur ! Source du renvoi introuvable.</i> (2)	Consortium Management activities <i>Erreur ! Source du renvoi introuvable.</i> (3)	Other specific activities <i>Erreur ! Source du renvoi introuvable.</i>				Total receipts <i>Erreur ! Source du renvoi introuvable.</i>		
		For transnational Access <i>Erreur ! Source du renvoi introuvable.</i>	For any other activities <i>Erreur ! Source du renvoi introuvable.</i>					Coordinating (4) <i>Erreur ! Source du renvoi introuvable.</i>	Transnational access (5) <i>Erreur ! Source du renvoi introuvable.</i>	Connectivity (6) <i>Erreur ! Source du renvoi introuvable.</i>	Other including Specific Service Activities for CND (7) <i>Erreur ! Source du renvoi introuvable.</i>		Total (8) = (1)+(2)+(3)+(4)+(5)+(6)+(7)	
9	FZR	AC		Direct costs (a)	132 500								137 500	
				Eligible costs	0									0
				Indirect costs (b)	26 500									
10	INFN	AC		Total eligible costs (a)+(b)	159 000								165 000	
				Requested EC contribution	132 500									138 500
				Direct costs (a)	600 467									658 217
11	TEU	FC		Eligible costs	0								0	
				Indirect costs (b)	120 093									131 643
				Total eligible costs (a)+(b)	720 560									789 860
12	TUL	AC		Requested EC contribution	658 600								727 900	
				Direct costs (a)	334 053									336 253
				Eligible costs	0									0
TOTAL	<i>Erreur ! Source du renvoi introuvable.</i>			Indirect costs (b)	107 417								107 417	
				Total eligible costs (a)+(b)	441 470									443 670
				Requested EC contribution	156 473									158 673
				Direct costs (a)	52 710								55 460	
				Eligible costs	0									0
				Indirect costs (b)	10 542									11 092
				Total eligible costs (a)+(b)	63 252								66 552	
				Requested EC contribution	63 252									66 552
				Eligible costs										66 552
				Requested EC contribution								66 552		

Please use as many copies of form A3.3 as necessary for the number of participants Form A3.3 page 3 of 6

Proposal Number <sup>1</sup>	506395	Proposal Acronym <sup>2</sup>	CARE
------------------------------	--------	-------------------------------	------

**Financial Information – “Reporting period 2 + first six months of Reporting period 3”**

Participant n° <i>Erreur ! Source du renvoi introuvable.</i>	Organization short name	Cost model used		Estimated eligible costs and requested EC contribution (first 18 months of the project)	RTD <i>Erreur ! Source du renvoi introuvable.</i> activities (1)	Demonstration activities <i>Erreur ! Source du renvoi introuvable.</i> (2)	Consortium Management activities <i>Erreur ! Source du renvoi introuvable.</i> (3)	Other specific activities <i>Erreur ! Source du renvoi introuvable.</i>				Total receipts <i>Erreur ! Source du renvoi introuvable.</i>			
		For transnational Access <i>Erreur ! Source du renvoi introuvable.</i>	For any other activities <i>Erreur ! Source du renvoi introuvable.</i>					Coordinating <i>Erreur ! Source du renvoi introuvable.</i> (4)	Transnational access <i>Erreur ! Source du renvoi introuvable.</i> (5)	Connectivity <i>Erreur ! Source du renvoi introuvable.</i> (6)	Other including Specific Service Activities for CND <i>Erreur ! Source du renvoi introuvable.</i> (7)		Total (8)= (1)+(2)+(3)+(4)+(5)+(6)+(7)		
13	IPJ	AC		Direct costs (a)	52 250								55 000		
				Eligible costs	0										0
				Indirect costs (b)	10 450										
14	WUT-ISE	AC		Total eligible costs (a)+(b)	62 700									66 000	
				Requested EC contribution	50 000										53 300
				Direct costs (a)	79 167										81 917
15	WUT	AC		Eligible costs	0									0	
				Indirect costs (b)	15 833										16 383
				Total eligible costs (a)+(b)	95 000										98 300
16	CSIC	FC		Requested EC contribution	95 000									98 300	
				Direct costs (a)	6 042										6 042
				Eligible costs	0										0
TOTAL	<i>Erreur ! Source du renvoi introuvable.</i>			Indirect costs (b)	1 208									1 208	
				Total eligible costs (a)+(b)	7 250										7 250
				Requested EC contribution	7 250										7 250
TOTAL	<i>Erreur ! Source du renvoi introuvable.</i>			Direct costs (a)	0									0	
				Eligible costs	0										0
				Total eligible costs (a)+(b)	15 500										15 500
TOTAL	<i>Erreur ! Source du renvoi introuvable.</i>			Indirect costs (b)	0									0	
				Total eligible costs (a)+(b)	0										0
				Requested EC contribution	0										0
TOTAL	<i>Erreur ! Source du renvoi introuvable.</i>			Eligible costs	0									0	
				Requested EC contribution	15 500										15 500
				Requested EC contribution	15 500										15 500

Please use as many copies of form A3.3 as necessary for the number of participants **4** of **6**

Proposal Number <sup>1</sup>	506395	Proposal Acronym <sup>2</sup>	CARE
------------------------------	--------	-------------------------------	------

**Financial Information – “Reporting period 2 + first six months of Reporting period 3”**

Participant n° <i>Erreur ! Source du renvoi introuvable.</i>	Organization short name	Cost model used		Estimated eligible costs and requested EC contribution (first 18 months of the project)	RTD <i>Erreur ! Source du renvoi introuvable.</i> activities (1)	Demonstration activities <i>Erreur ! Source du renvoi introuvable.</i> (2)	Consortium Management activities <i>Erreur ! Source du renvoi introuvable.</i> (3)	Other specific activities <i>Erreur ! Source du renvoi introuvable.</i>				Total receipts <i>Erreur ! Source du renvoi introuvable.</i>			
		For transnational Access <i>Erreur ! Source du renvoi introuvable.</i>	For any other activities <i>Erreur ! Source du renvoi introuvable.</i>					Coordinating <i>Erreur ! Source du renvoi introuvable.</i> (4)	Transnational access <i>Erreur ! Source du renvoi introuvable.</i> (5)	Connectivity <i>Erreur ! Source du renvoi introuvable.</i> (6)	Other including Specific Service Activities for CND <i>Erreur ! Source du renvoi introuvable.</i> (7)		Total (8)= (1)+(2)+(3)+ (4)+(5)+(6)+ (7)		
17	CERN	AC		Direct costs (a)	1 403 900								1 540 203		
				Eligible costs	465 000										465 000
				Indirect costs (b)	187 780										
				Total eligible costs (a)+(b)	1 591 680								1 755 244		
				Requested EC contribution	1 151 900								1 315 464		
18	UNI-GE	AC		Direct costs (a)	0									23 914	
				Eligible costs	0										0
				Indirect costs (b)	0										
				Total eligible costs (a)+(b)	0								23 914		
				Requested EC contribution	(0)*								(23 914)*		
19	PSI	FC		Direct costs (a)	70 061									78 281	
				Eligible costs	0										0
				Indirect costs (b)	17 516										
				Total eligible costs (a)+(b)	87 577								95 797		
				Requested EC contribution	(87 577)*								(95 797)*		
20	CCLRC	FC		Direct costs (a)	716 154									743 704	
				Eligible costs	0										0
				Indirect costs (b)	576 110										
				Total eligible costs (a)+(b)	1 292 264								1 319 814		
				Requested EC contribution	175 807								203 357		
<b>TOTAL</b> <i>Erreur ! Source du renvoi introuvable.</i>				Eligible costs											
				Requested EC contribution											

Proposal Number <sup>1</sup>	506395	Proposal Acronym <sup>2</sup>	CARE
------------------------------	--------	-------------------------------	------

Participant n° <i>Erreur ! Source du renvoi introuvable.</i>	Organization short name	Cost model used		Estimated eligible costs and requested EC contribution (first 18 months of the project)	Other specific activities <i>Erreur ! Source du renvoi introuvable.</i>				Total receipts <i>Erreur ! Source du renvoi introuvable.</i>												
		For transnational Access <i>Erreur ! Source du renvoi introuvable.</i>	For any other activities <i>Erreur ! Source du renvoi introuvable.</i>		RTD <i>Erreur ! Source du renvoi introuvable.</i>	Demonstration activities <i>Erreur ! Source du renvoi introuvable.</i>	Consortium Management activities <i>Erreur ! Source du renvoi introuvable.</i>	Coordinating Network <i>Erreur ! Source du renvoi introuvable.</i>		Transnational access <i>Erreur ! Source du renvoi introuvable.</i>	Connectivity <i>Erreur ! Source du renvoi introuvable.</i>	Other including Specific Service Activities for CND <i>Erreur ! Source du renvoi introuvable.</i>									
21	ICL		AC	Direct costs (a) Eligible costs Indirect costs (b) Total eligible costs (a)+(b) Requested EC contribution	0	29 667	0	0	0	29 667											
22	UMA		AC	Direct costs (a) Eligible costs Indirect costs (b) Total eligible costs (a)+(b) Requested EC contribution	0	2 433	0	0	0	2 433											
<b>TOTAL</b>	<b>Erreur ! Source du renvoi introuvable.</b>			Eligible costs Requested EC contribution	<b>11 825 690</b> <b>11 825 690</b> <b>(+87 577 )*</b>	<b>447 600</b> <b>187 260</b>	<b>566 125</b> <b>533 989</b> <b>(+32 134)*</b>	<b>0</b>	<b>0</b>	<b>12 839 415</b> <b>5 644 485</b> <b>(+119711)*</b>											

Please use as many copies of form A3.3 as necessary for the number of participants **6** of **6** Form A3.3 page

\*Since the contract with EU was not signed in 2003 and the agreement on Swiss participation in the 6th FP was not yet be in force when the CARE contract was signed, Swiss Partners should be funded by the Swiss Government.