

# ATLAS SCT Hybrids Experience

Y. Unno

Institute of Particle and Nuclear Studies, High Energy Accelerator Research Organization (KEK), Tsukuba 305-0801, Japan  
yoshinobu.unno@kek.jp

## Abstract

The hybrids of ATLAS semi-conductor tracker (SCT) were made with Cu/Polyimide flex-circuits, reinforced with carbon-carbon substrates, in the barrel and in the endcap modules. We report successes, problems and solutions in the course of production of 2600 pieces of hybrids each.

## I. INTRODUCTION

As LHC turn-on is scheduled in two years, the construction of SCT barrel and endcap systems [1] is in the last corner of assembling. Module assembly is completed for the 2112 barrel and 1976 endcap modules for the experiment together with additional spares of >10% modules. Macro assembly of four individual cylinders with the barrel modules mounted is completed. Assembly of endcap disks with the endcap modules is in progress. Installation of four barrel-cylinders into the barrel thermal enclosure is in progress as shown in Figure 1.

Through the construction of barrel and endcap modules, we have gained valuable experiences in manufacturing the hybrids. We report a summary of these experiences for the series production of 2600 pieces in the barrel and the endcap hybrids each.

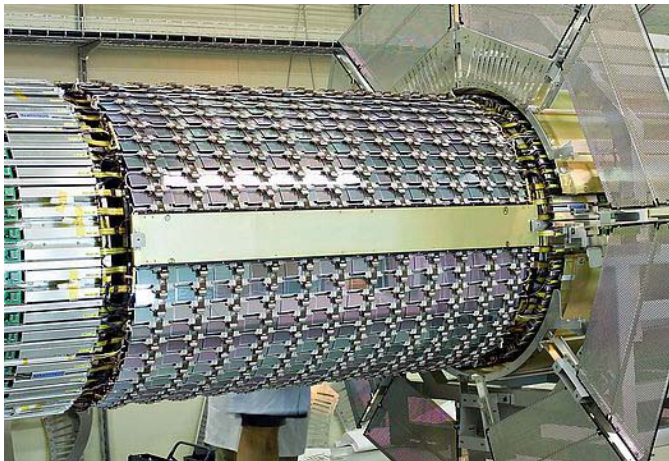

Figure 1 Installation of SCT-barrel-cylinders into the thermal enclosure

## II. ATLAS SCT BARREL HYBRID

The ATLAS SCT barrel module is shown in Figure 2. The module is made of 4 silicon microstrip sensors (64.0 mm long and 63.6 mm wide, each), 2 on top- and 2 on backside, and with a stereo angle of 40 mrad. The strips of 768 per side

with a strip pitch of 80 microns are read by front-end electronics, the ABCD application-specific-integrated-circuit (ASIC) chips [2]; 6 ASIC's per side and 12 ASIC's total that dissipate a power of 5W. The hybrid that carries the ASIC's is placed at the centre region of the module. The layout enables to have clean ends along the horizontal axis for close overlapping of the adjacent modules. Sensing the strips at the centre is reducing the input series resistance of the strips by 1/4 compared with sensing the strips at end, thus reducing the series resistance noise by about 100e. The mechanical structure of the hybrid at the centre is also reinforcing the module integrity.

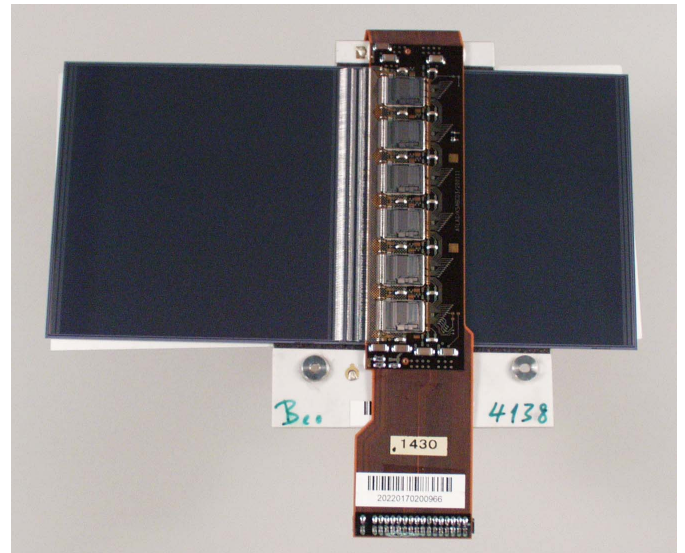

Figure 2 SCT barrel module

The cross section of the module at the hybrid is shown in Figure 3. The hybrid is made of Cu/Polyimide flex-circuit, reinforced with carbon-carbon substrates, and wrapping around the module. The carbon-carbon substrates are bridging over the sensors for the minimum damage to the sensors. The Cu/Polyimide flex-circuit, together with the carbon substrates, makes the hybrid to have low radiation length, good electrical stability with the thick and low-resistance conductor planes of copper, and one continuous construction from the connector to the far-end of ASIC's. The one-piece construction of the hybrid eliminates vulnerable connections between the cables and the sections of ASIC's.

The carbon-carbon substrate [3] gives good mechanical strength (Young's modulus of 294Gpa; as similar as ceramics), good thermal conductivity (700W/K/m) and low radiation length. The radiation length of the hybrid is  $(0.32\%+0.06\%(\text{ASIC's})) X_0$  averaged over one module area of 128 mm x 64 mm.

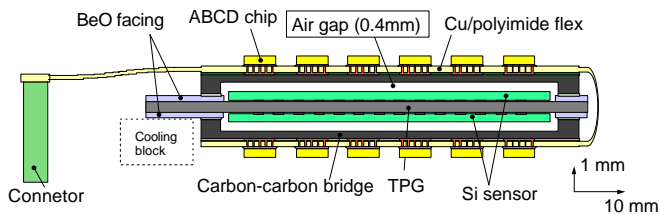

Figure 3 Cross-section of SCT barrel module

An expanded view of the hybrid is shown in Figure 4. The two ASIC sections are set off for making the stereo angle of 40 mrad, when the hybrid is wrapped around the module. The ASIC pads are visible on the ASIC sections. The front area of the pads has through-holes filled with a conductive epoxy for good thermal conduction of ASIC heat to the carbon-carbon substrate. The sections in front of the ASIC pads are fitted with the pitch-adapters described in the sub-section B.

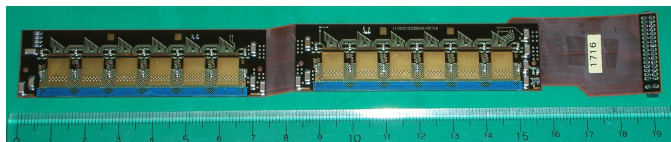

Figure 4 SCT barrel hybrid

### A. Cu/Polyimide Flex-circuit

A vendor in Japan produced the Cu/Polyimide flex-circuits for the barrel hybrids [4]. The vendor had the market share of about 50% worldwide in the flex-circuit fabrication (in 1996) and we have been working with the vendor for past 10 years. Their broad experience and knowledge could have been critical for the success of the hybrid.

#### 1) Cu/Polyimide Flex-circuit Design Rules

The design of the Cu/Polyimide flex-circuit was an outcome of numerous interactions with the vendor and circuit designer. The fabrication masks were optimised at the vendor for production. The standard trace width and gap were metal width of 150 microns and gap of 150 microns. The minimum width and gap were 100 microns and 80 microns that were applied to the lands for wire-bonding between the backend pads of the ASIC's.

A few design rules of the vendor are reproduced in Figure 5 from the vendor's publication [5]. The trace patterns are to avoid abrupt changes, i.e., to have the teardrop shape. The ends of land patterns are to be held by the cover film against peeling. The mechanical abrupt junctions, e.g., bending points are to be reinforced with a cover film and the edges of the reinforcement plates and films are to be overlapped. Any cautions should be taken to protect the traces from breaking as the flex-circuit is subject to flexing which is often missed in the rigid PCB designs.

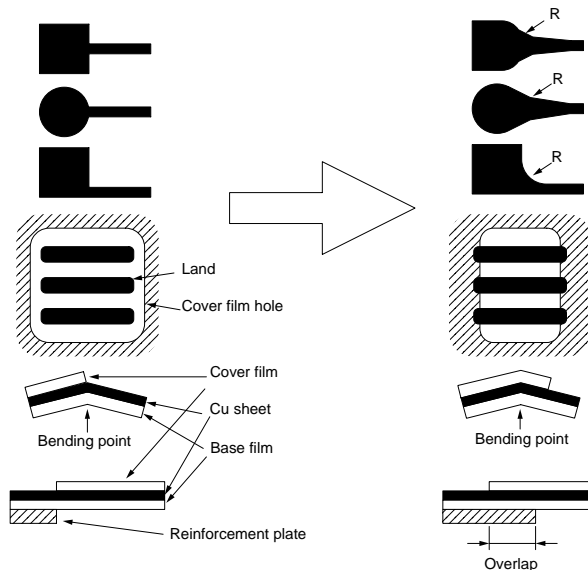

Figure 5 Cu/Polyimide flex circuit design rules from the ref. [5]

#### 2) Layer construction

The layer construction of the flex-circuit is shown in Figure 6. The central core is made of double-sided copper/polyimide sheet that run through the hybrid from the connector to the far-end. Single-sided copper/polyimide sheets are built up on the top- and the bottom-side of the central core to make into four metal layers. The major function of the metal layers is, from the top layer, traces to the surface mount devices including the ASIC's (Layer 1), bus lines (Layer 2), analogue and digital ground planes (Layer 3), and analogue and digital power supply planes (Layer 4). The layers between 1 and 4 are electrically connected by through-holes (300 microns diameter) made with mechanical drilling and the layers between 1 and 2 are connected by via's (150 microns diameter) with laser drilling. The top and the bottom layers are removed at the cable sections for flexibility. The connector section is left with four layers for reinforcement although two layers are sufficient for electrical connections.

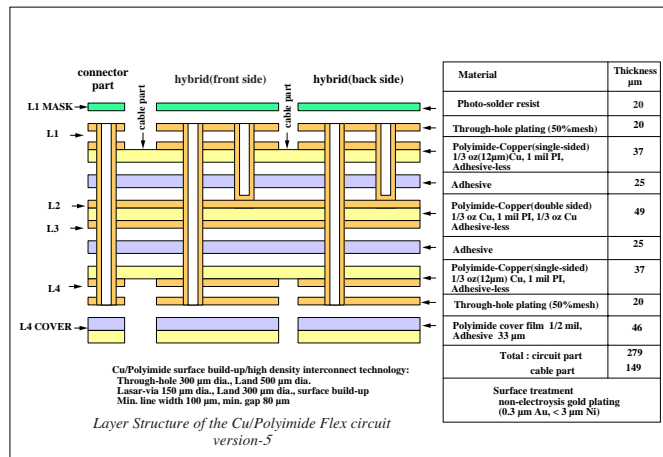

Figure 6 Layer construction of SCT barrel Cu/Polyimide flex-circuit

### 3) Quality Assurance of Flex-circuit at Vendor

The vendor has thorough lists of visual inspections, mechanical and electrical tests that ensure the quality and integrity of flex-circuit (see e.g., ref. [5]). The visual inspections are to check the design features, sizes and structures, the nicks and pinholes on conductors, the protrusions and residual conductors, the entrapped foreign materials, the wrinkles and fold lines, the air bubbles, the dents and delamination of conductors, the scratches on conductors, the discolorations and corrosions, the adhesive squeeze-outs, the adhesive stains, the non-plating spots, the mis-registrations, the through-hole cross-sections, etc. The mechanical tests are the peel test, etc. The electrical tests are the open/short test of all traces, etc. These thorough lists are the strength of experienced vendors.

### B. Aluminium Traces-on-Glass Pitch-Adapter

In order to match the different pitches of the silicon microstrip sensors (80 microns) and the ASIC's (48 microns) a pitch-adapter (PA) was designed with the aluminium traces on glass substrate as shown in Figure 7. The metal was pure aluminium of 1 microns thick deposited on the glass of 200 microns thick. The narrow metal width and gap of 15 microns and 15 microns were impossible with the Cu/Polyimide flex-circuit technology. There was no passivation over the aluminium traces.

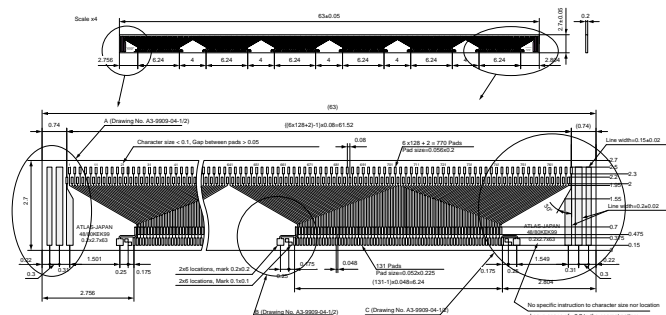

Figure 7 SCT barrel aluminium-on-glass pitch-adapter: overall (top) and enlarged sections (bottom)

### C. Barrel Experience

We have experienced no trouble in Cu/Polyimide flex-circuits or in carbon-carbon substrates. We owe both to high quality and deep knowledge of the vendors. We have produced 2600 and more hybrids successfully [6]. We have, however, experienced problems: surface contamination from protection films and generation of "whiskers" in the PA's, and solved them in the course of production.

#### 1) Surface Contamination from Protection Film

The Cu/Polyimide flex-circuits and the carbon-carbon substrates were bonded with heat-curing epoxy adhesives, compressed with a press jig in an oven with an elevated temperature of 125 deg.C. The heat-press jig is shown in Figure 8. The hybrid was set with a curvature in order to

match the elongations of the flex-circuit and the carbon-carbon substrate at the elevated temperature. The surface of the flex-circuit was covered with a protection film during the bonding process. Although we used an adhesive film with weak sticking force, the adhesive was trans-printed from the film to the surface of the flex-circuit. The amount was varied lot-by-lot of adhesive films. The contamination accumulated residues on the wedge of wire-bonders and also degraded wire-bond pull strength. The problem was solved by applying argon-plasma cleaning on the surface of the hybrids, together with selecting low trans-printing adhesive films.

Adhesive contamination was also observed in the PA's. The surface was protected with the same protection film and the PA's were pressed when they were bonded to the flex-circuit at an elevated temperature of 40 deg.C. Applying the argon-plasma cleaning made the wire-bonds less sticking on the aluminium, which reason is still under investigation. The contamination on the PA's was cleaned with alcohol-dipped cotton-tips by hand.

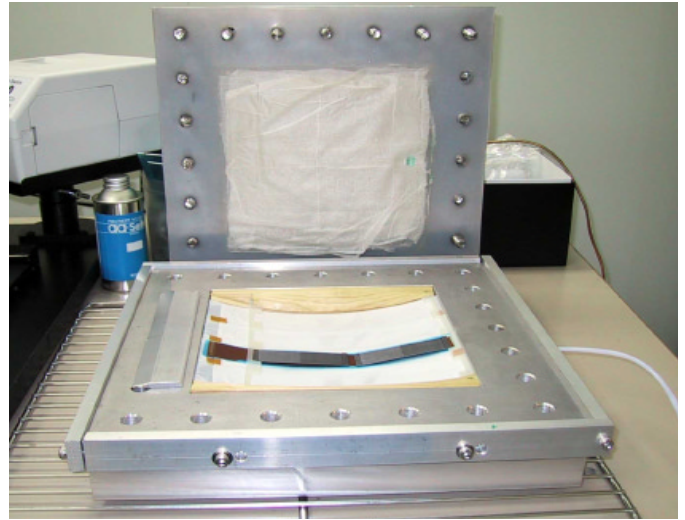

Figure 8 The heat-press jig for the SCT barrel hybrid

#### 2) Generation of Whiskers in PA

Generation of whiskers around the feet of wire-bonds in the PA's was noticed around the production of about 400 pieces of hybrids (about 15% of 2600 pieces) although little generation of whiskers was confirmed in the pre-series production of about 50 hybrids. The whiskers ranged from null to a few tens microns and appeared at end or side and thick or fine in shape. The generation of whiskers was associated with varied fraction of peels of feet in the pull tests. Also, the amount and the size of whiskers varied with bonding machines. A generation of typical whiskers in the PA's is shown in Figure 9.

After the observation of the whiskers, the aluminium metalisation process was reviewed and improved for less generation of whiskers. Despite the effort to reduce the generation of whiskers, the quality of PA's was degraded once again around production of about 1200 (45%) and 1800 (70%) pieces of the hybrids. Although we were not free from whiskers in the pads of the silicon microstrip sensors, ASIC's,



and in the surface of pure-aluminium foils, we cared the whiskers in the PA's because the gap of the trace metals was only 15 microns.

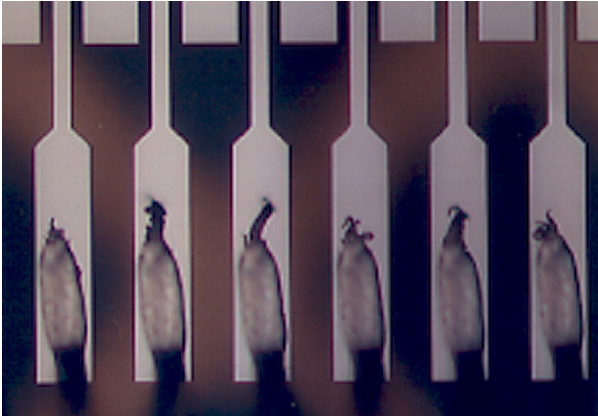

Figure 9 Typical whiskers generated in PA before improved

Only good lots of PA's were selected for fabrication into the hybrids, after wire-bonding tests for the generation of whiskers and the pull strength. At around the production of 70%, since the yield of good PA's was degraded to about 70%, a thorough investigation was intervened the production. The investigation involved different vendors/processes, different deposition alloys, and different substrates.

The PA's from different vendors/processes differed in generation of whiskers and yields. Pure aluminium or alloy of Al+1%Si gave little difference. A piece of critical information came from the comparison of aluminium deposition on glass and on silicon substrate. The aluminium-on-silicon gave good and uniform quality in all area of substrate, while the aluminium-on-glass gave good quality only in the peripheral and worse in the centre of the substrate. The insight into the observation suggested that the critical parameter was the temperature of substrate during the aluminium deposition. The glass is a bad thermal conductor compared with the silicon.

With these insights, a process of better quality was selected and the deposition condition was set to a low temperature (i.e., the room temp.) and to keep the temperature uniform over whole glass area in the glasses in the deposition chamber. The generation of whiskers is thought correlated with the hardness of the aluminium deposited. The low temperature makes the hardness adequate for little generation of whiskers in the wirebonding as seen in the improved metalisation shown in Figure 10. The condition seemingly also improved the fraction of peels.

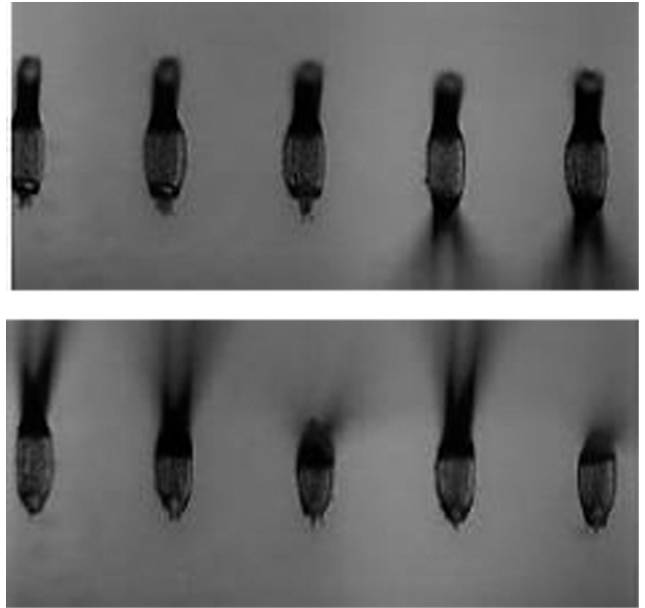

Figure 10 Little appearance of whiskers after the improvement: the first bonds and the wires are removed in the left three feet (top), and the second bonds (bottom)

### III. ATLAS SCT ENDCAP HYBRID

A SCT endcap module is shown in Figure 11. The module is for the inner ring of the endcap disks and uses single sensor per side. The hybrid is set at the end of sensors, and the cooling contact for the hybrid and the sensor is at the middle of hybrid, together with a separate cooling contact at the end of sensors. The design was driven by the geometry of the module layout in the endcap disks.

An expanded view of the endcap hybrid is shown in Figure 12. The flex-circuit is made with Cu/Polyimide technology with 6 metal layers [7]. In order to achieve the electrical stability of the ASIC's (suppressing coupling of digital switching into analogue front-end amplifiers), extra continuous analogue power and ground planes were introduced. The ASIC sections wrap around a carbon-carbon substrate in a butterfly style.

The carbon-carbon substrate [3] functions as a mechanical, thermal, and electrical component. There are cut windows under ASIC's in the Cu/Polyimide flex-circuit, filled with aluminium-nitride inlays, to improve heat transfer from the chips into the carbon-carbon substrate. The locations of the cut windows are optimised for equalising the temperature of ASIC's in the hybrid.

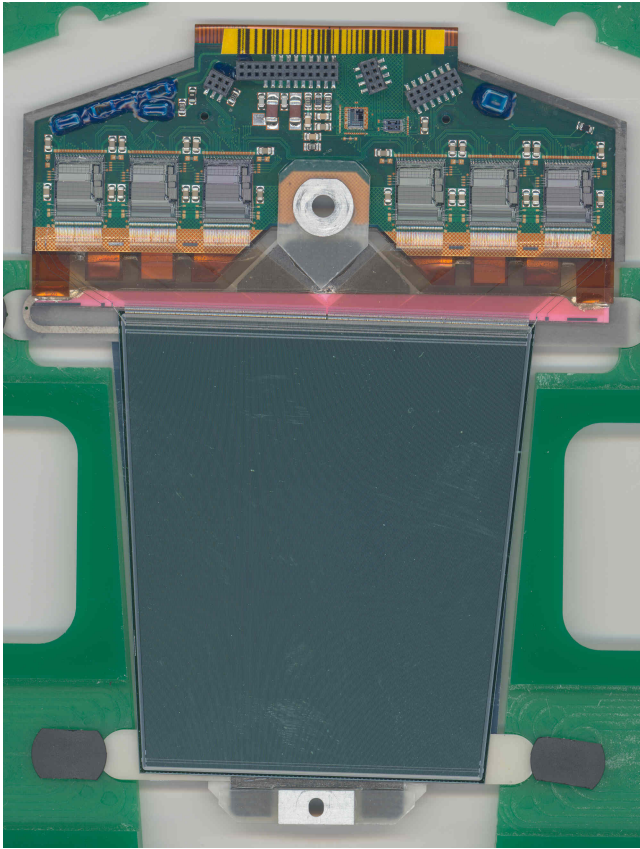

Figure 11 SCT endcap inner module

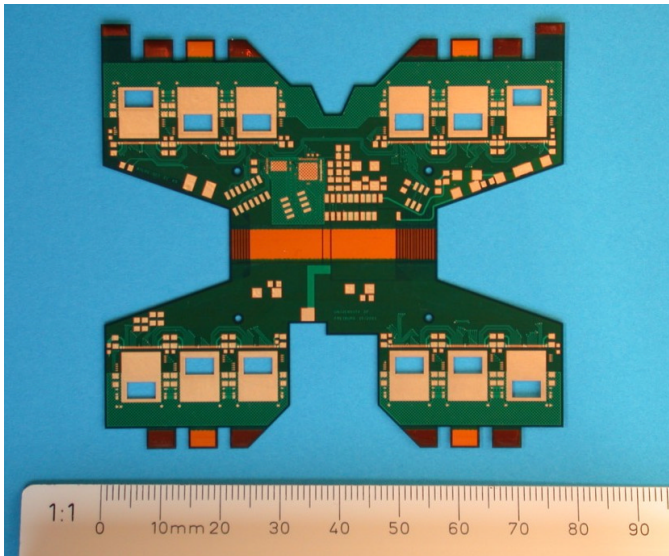

Figure 12 SCT endcap Cu/Polyimide flex-circuit

#### D. Endcap Experience

We have fabricated 2,586 hybrids successfully [8]. The yield of hybrids was high (98%) through very close and fruitful collaboration with industrial producers. There was little whisker problem in the endcap PA's. The endcap PA's were made with an alloy of Al+0.5%Cu.

We have encountered a problem in the Cu/Polyimide flex-circuit: delamination of layers after the production of about 50% pieces. The delamination was visible as bubbles trapped between the layers in various places. The problem was mitigated by careful control of lamination parameters. The key for the success was close cooperation with industry with frequent contacts and visits to the production line.

#### IV. SUMMARY

ATLAS SCT hybrids are made with Cu/Polyimide flex-circuit technology, widely used in commercial products, together with a carbon-carbon substrate reinforcing the flex-circuit, mechanically, thermally, and electrically. The barrel and endcap hybrids were fabricated successfully in quantity of about 2600 each. There was no problem in the Cu/Polyimide flex-circuits in the barrel hybrids due to proper design rules and thorough inspections in the experienced vendor. The major problem in the barrel hybrids was the generation of whiskers in the aluminium-on-glass PA's. The mitigation was found by keeping the temperature of the glasses under the metal deposition low and uniform, plausibly making the hardness of aluminium adequate for wirebonding. In the endcap hybrids, the problem was delamination of layers in the Cu/Polyimide flex-circuit that was mitigated by careful control of lamination parameters. These problems have occurred after fabrication of large quantities, several hundreds to more than 1000 pieces. Close monitoring of the products has been critical to spot a problem. Working with experienced vendors and close cooperation with industries have been the keys to the successes.

#### V. ACKNOWLEDGEMENT

The barrel hybrids were designed and fabricated by the team of ATLAS-Japan silicon collaboration and ATLAS SCT barrel module collaboration. The endcap hybrids were by the Univ. of Freiburg and ATLAS SCT endcap module collaboration.

#### VI. REFERENCES

- [1] ATLAS Inner Detector Technical Design Report Vol.1 and 2, CERN/LHCC 97-16 and 97-17
- [2] Design and performance of the ABCD3TA ASIC for readout of silicon strip detectors in the ATLAS semiconductor tracker, Nucl. Instr. Meth. A552 (2005) 292-328
- [3] Produced by CF business div., Nippon Oil Corporation, 1-3-12 Nishi-Shinbashi, Minato-ku, Tokyo 105-8412, Japan
- [4] Nippon Mektron Ltd, 1-12-15 Shiba-Daimon, Minato-ku, Tokyo 105-0012, Japan
- [5] Flexible Interconnection System, CAT. NO. 612E-02-97-2K, published by Nippon Mektron Ltd.
- [6] Seiko Precision Inc., 1864 Ienaka, Tsuga-machi, Shimo-Tsuga-gun, Tochigi-ken 328-0111, Japan
- [7] Cicorel SA, Route de l'Europe 8, 2017 Boudry, Switzerland
- [8] Hybrid SA, Combamare 19, CH-2025 Chez-le-Bart, Switzerland