

PROGRESS IN HIGH DENSITY PROJECTION CHAMBERS

E. Albrecht, G. Cerutti, H.G. Fischer, M. Flammier, P.G. Innocenti, J.C. Legrand,
E. Lillethun*, G. Mourgue and O. Ullaland

CERN, Geneva, Switzerland

The High density Projection Chamber (HPC) is a sampling calorimeter where shower conversion and detection is separated. It offers a simple and homogeneous large volume detector with an energy resolution of $(10-11)\%/ \sqrt{E}$, an inherent resolution transverse to the shower axis of 100 μm and an exceptionally fine granularity along the shower. The use of this detector in a colliding beam experiment will be discussed.

Introduction

The expected well collimated jet topology of the event structure at the new colliding beam facilities will put new demands on the capabilities of the detectors to separate electrons from hadrons and single gammas from π^0 decays. The HPC¹ aims at giving a uniform and fine grained coverage of the total solid angle maintaining a good energy resolution. In contrast to more classical devices the HPC adds fine granularity along the shower and not only transverse to the shower axis, a feature which is required for an excellent discrimination between electromagnetic and hadronic showers. The read-out of space points will in addition simplify the pattern recognition.

In this paper we are discussing the features of the HPC as an electromagnetic shower detector in a colliding beam experiment (fig. 1). The converter is a laminated stack of grid structured lead plates. Each plate is electrically insulated from its neighbour by an epoxy coating. This also serves as a plate-to-plate bonding of the stack. The grids will in this way be superimposed and make up long sampling slots perpendicular to the incident particle trajectories (fig. 1(b)).

The electrons are then drifted along the sampling slot/drift channel onto the active detector plane under the influence of an electric field built up by a simple voltage gradient between the plates.

The detector is a single plane proportional chamber with cathode pad read-out (fig. 1(c)). The gas amplification field and the drift field are decoupled via a cathode wire grid. The grid is made of 100 μm diameter copper wires which are spaced by 1 mm (fig. 2). The charge transparency of such a grid has been investigated. For $E_{\text{chamber}}/E_{\text{drift}} > 6$ there is full charge transmission, in agreement with previously published data².

The converter structure with its pick up chamber is placed inside the solenoidal field of the analyzing magnet. This solution minimizes the material in front of the calorimeter. Since the magnetic field is parallel to the electric field it has no adverse effect on the charge transport.

Read-out system

The main components of the read-out system are shown in fig. 3. The two projected coordinates are given by the cathode pad size (fig. 1(c)). With only one read-out plane for a drift length of more than a meter the system facilitates an optimization of the granularity along and transverse to the shower axis. The coordinate along the drift channel is given by the drift time of the charges. This is done with a duplex charge integrator system. The induced charges on each cathode pad are integrated in small time buckets. One integrator can then be read out and reset via a fast

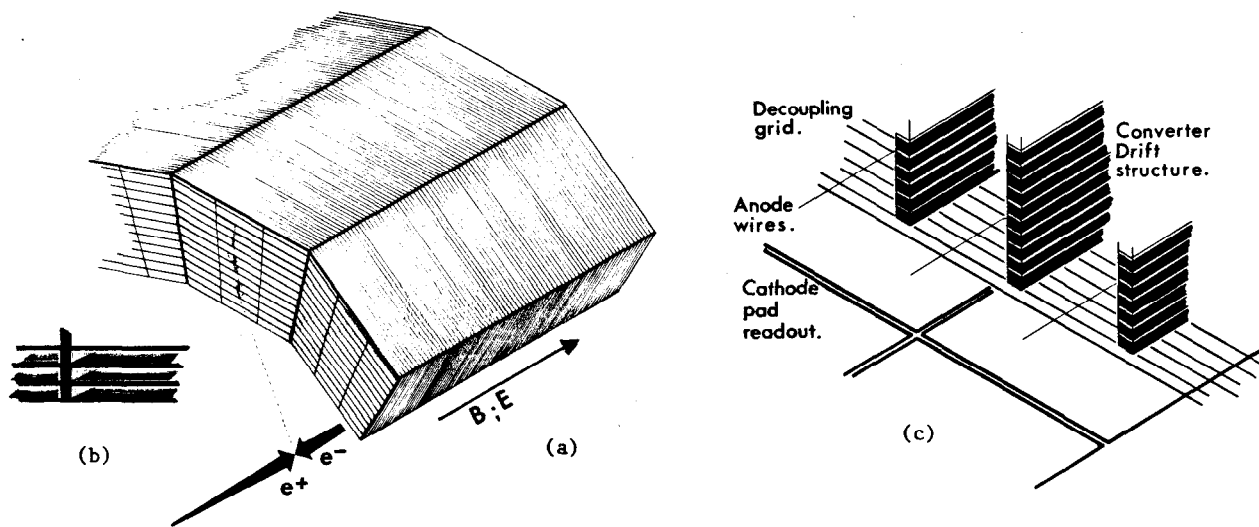

Fig. 1 - (a) Long drift High density Projection Chamber modules enclose a beam intersection region. (b) Detail of the sampling structure. (c) Layout of the pick up chamber.

(*) On leave of absence from University of Bergen, Norway.

analog to digital converter, during the time the other integrator on the same line accumulates the incoming charges. We are planning to work with time buckets 100-200 ns long. This corresponds to a few mm drift length depending on the gas mixture and the drift voltage.

The inherent space resolution of this detector is about 100 μm in the transverse plane if we use the centre of gravity method. Longitudinal to the shower axis the space resolution is one sampling gap wide. It should be pointed out that the resolution along the drift direction is only dependent on the length of the time bucket and the drift velocity and does not increase the number of electronics channels.

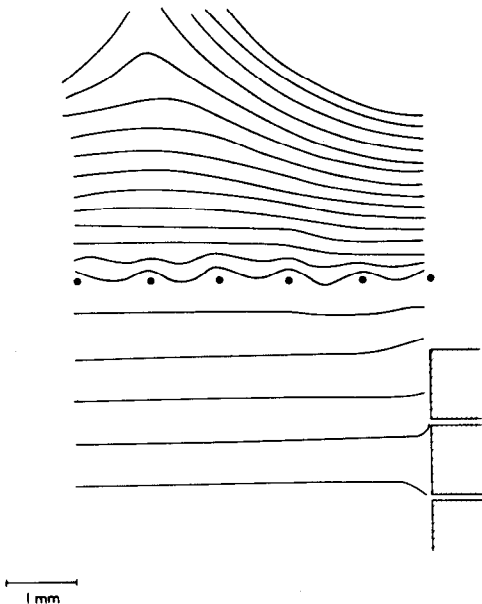

Fig. 2 - Equipotential lines at the junction between the converter stack and the pick-up chamber. The points represent the 100 μm diameter grid wires.

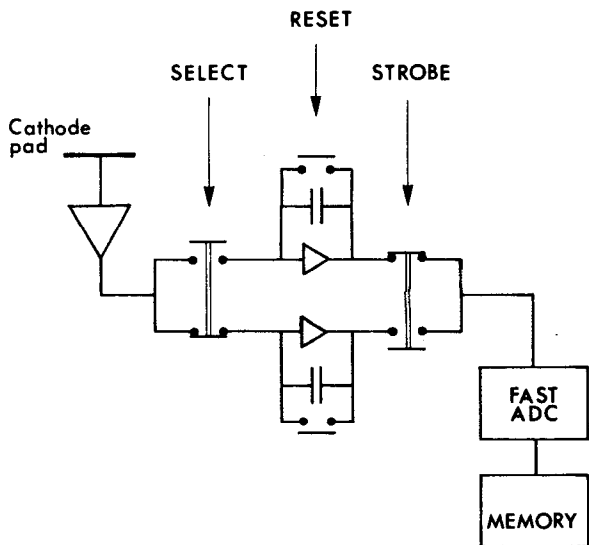

Fig. 3 - Schematic diagram of the HPC electronics.

Charge transport

We have previously published data on charge transport in a confined geometry¹. Only diffusion inflicted charge losses play a role when the ratio between the gas gap and the step size of the electric field is optimized. Attenuation lengths of 15 m have been observed in a drift channel made up of 10 mm gas and 1 mm plate thickness. The gas mixture was 80% Ar/20% CO₂.

We have limited our choice of gas mixtures to the ones used by the ISIS³ and the TPC⁴ groups. The diffusion coefficients in 80% Ar/20% CO₂ and 80% Ar/20% CH₄ gas mixtures at NTP have been investigated. The characteristic energy spectrum from a Fe⁵⁵ gamma source is a valuable tool to determine the transverse diffusion behaviour of a single electron. The observed gamma spectrum has two energy lines, the escape line at ~ 3 keV and the Auger line at ~ 6 keV. The charge losses due to the diffusion of the electrons into the walls of the drift channel result in a characteristic filling up of the valley between the two lines. A Monte-Carlo program has been set up to simulate the physical processes from the gamma conversion to the gas amplification on the anode wire. It can thereby be shown that the ratio between the height of the Auger peak and the valley between the two energy lines is a measure of the transverse diffusion for a single electron (fig. 4).

The measurements for 20% CO₂ and 20% CH₄ admixture in argon is shown in figs 5 and 6 together with other data for transverse and longitudinal diffusion.

CO₂ is known to be an excellent electron cooling gas^{3,6} where the influence of the argon plays no major role in the diffusion process. Our measurements are here in excellent agreement with the data⁶ from pure CO₂ scaled to its partial pressure. Also the direct measurement⁵ of the longitudinal diffusion in 80% Ar/20% CO₂ coincides with our data points.

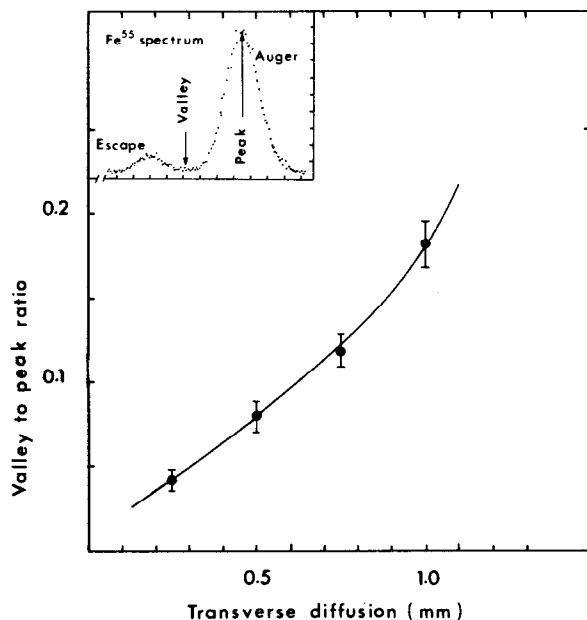

Fig. 4 - Simulation calculation of the transverse diffusion as a function of the ratio of the counting rate at the Auger line and the valley between the Auger and the escape line.

The transverse diffusion coefficient for 20% CH₄ exhibits a much stronger dependence on the electric field than in the case of the CO₂. We find here a minimum at about 90 V/cm where as it is about 450 V/cm at NTP in the gas mixture with CO₂. We do not however observe the strong deteriorations of the transverse diffusion by going from 20% CO₂ to 20% CH₄ admixture in argon as reported by the TPC group⁴.

We have also investigated the electron drift efficiency under the influence of a magnetic field. It can be shown⁹ that the deflection angle, θ , due to a magnetic field, B, perpendicular to the electric field can be written as

$$\text{tg}\theta = \omega\tau = a * B.$$

The best fit to our data gives $a = 0.27 \text{ Tesla}^{-1}$. This corresponds to an overall charge displacement of 1 mm for 40 Gaussmeter perpendicular to the drift direction.

Electron capture by positive ions¹⁰ is not expected to give any problems since the electronics chain enables us to work at a gas amplification of only a few thousand. The converter structure should also be effectively shielded against background events. Oxygen contamination will however deteriorate the attenuation length in a gas mixture with CO₂¹. Methane is less critical. For this gas, no influence on the drift properties have been observed for O₂ concentrations smaller than 80 ppm.

The calorimeter

We have demonstrated that the charge transport causes no problem in the converter structure. The projected charge includes all the necessary information for the detector to operate as a fine grained quantameter.

Two calorimeter modules with a geometry similar to the one shown in fig. 1 have been built. The first one has a copper converter with 18 samples 2/3 X₀ apart. It was used for optimization of the drift properties and of the charge collection efficiency¹. It has also been run in an electron beam to study its resolution. The EGS¹¹ program was used to simulate the detector. The measured and expected energy resolution coincide (fig. 7).

The second module is a lead converter stack. The converter plates are lead frames with 1.5 mm wide lead bars spaced 10 mm apart. A 50 μm epoxy insulator bonding layer is deposited on the grids with a silk screen printing technique. The stress exerted perpendicular to the lead bars is taken up by spokes running from the front of the module to the back of it (fig. 1). These thin stiffening spokes are placed ~ 20 cm apart. Further optimization of the internal stability is under study by minimizing the number of spokes without losing the self stable structure.

Energy resolution

As far as energy resolution is concerned, the HPC performance should be superior to the one expected for normal multiwire proportional quantameters¹². This has two main reasons:

- (a) The good granularity allows the study of the three-dimensional shower development with high resolution. At energies below about 2 GeV, simple digital counting methods of set detector cells or rows of such cells should yield a resolution close to the lower limit given by the fluctuation of the number of shower electrons¹³. The additional

information due to the analog charge measurement in each drift cell, will avoid saturation effects close to the shower axis at higher energies.

- (b) The magnetic field orthogonal to the shower axis eliminates most of the track length fluctuations which are known to deteriorate the energy resolution: low energy, large angle shower electrons are quickly bent back into the lead converter.

On the other hand, long range ionization electrons produced in the gas, which will be trapped by the magnetic field, can be recognized and eliminated by their characteristic track pattern along the field lines.

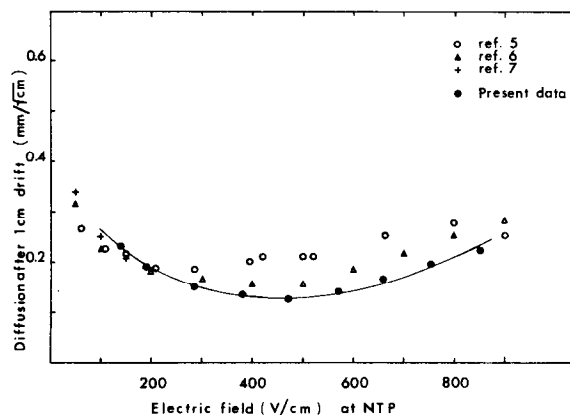

Fig. 5 - Electron diffusion as a function of the electric field in 80% Ar/20% CO₂. One measurement of the transverse component is compared to the longitudinal in the same gas⁵. The data from R.W. Warren et al.⁶ and E.B. Wagner et al.⁷ are in CO₂ and recalculated for 0.2 atm of CO₂.

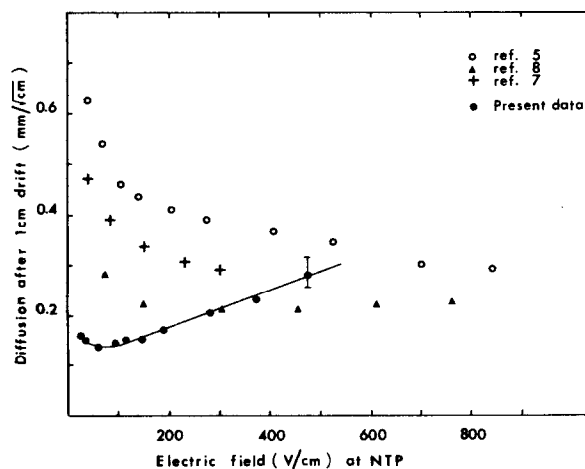

Fig. 6 - Electron diffusion as a function of the electric field in 80% Ar/20% CH₄. Our measurement of the transverse component is compared to T.L. Cottrell et al.⁸ in CH₄. Also plotted is the measurement from F. Piuze⁵ of the longitudinal diffusion in 80% Ar/20% CH₄ together with E.B. Wagner et al.⁷ in CH₄.

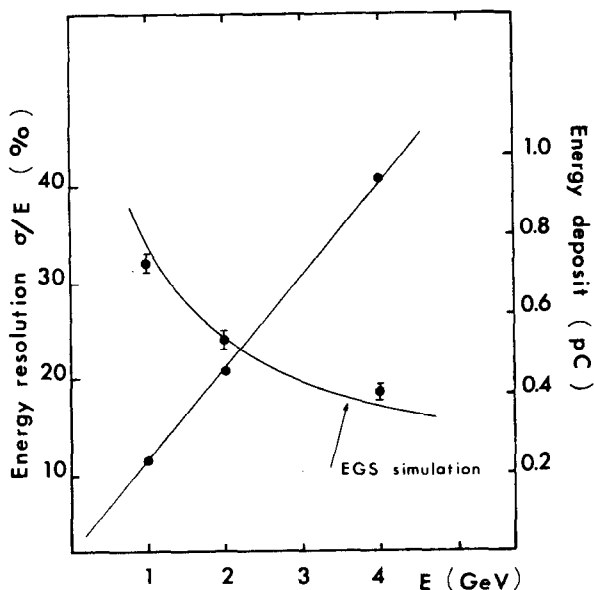

Fig. 7 - Energy resolution and energy response for electron showers in a test module with 18 samples over 13 radiation lengths of copper. The energy resolution is compared to a Monte-Carlo simulation.

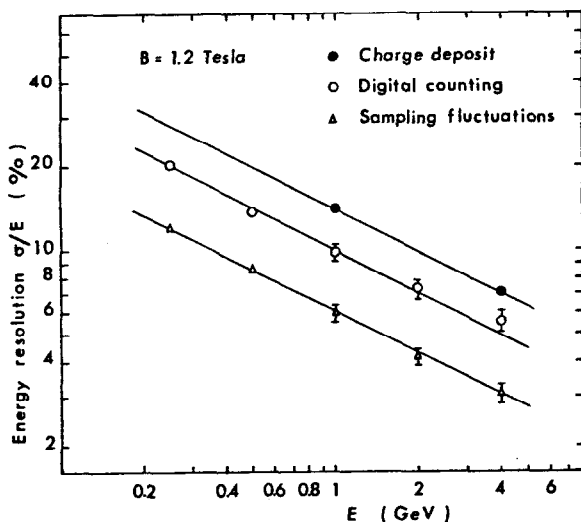

Fig. 8 - EGS calculation of the energy resolution in a lead converter structure with 60 samples $1/3 X_0$ apart.

We are at present studying some of the possibilities indicated above with the EGS Monte-Carlo routine¹¹ adapted to operation in a magnetic field¹⁴. Preliminary results suggest that resolutions of $(10-11)\%/\sqrt{E}$ can be achieved with a sampling thickness of $1/3 X_0$ of lead (fig. 8).

It is however clear that the full potential of this new device will only reveal itself in conjunction with powerful pattern recognition techniques. This is especially true for an environment like LEP where problems like shower overlap and hadron rejection become a major concern.

Conclusion

The HPC is a promising calorimeter for future colliding beam experiments. It is a simple and stable large volume detector with few active elements which offers high spatial and energy resolution.

We are indebted to A. Pullia and S. Ragazzi, University of Milano, M. Jezabek, University of Cracow, and P.S. Iversen, University of Bergen, for their shower calculations. We wish to thank A. Minten for his active interest and support. Also acknowledged is the effort of the CERN technical services in the realization of the converter modules.

References

1. H.G. Fischer and O. Ullaland, IEEE Trans. Nucl. Sci. NS-27 (1980) 38.
2. S.C. Curran and H.W. Wilson, ed. K. Siegbahn, Alpha, Beta and Gamma Ray Spectroscopy (North Holland 1965);
A. Breskin et al., Nucl. Instr. Meth. 161 (1979) 19.
3. W.W.M. Allison et al., Nucl. Instr. Meth. 119 (1974) 499.
4. D. Fancher et al., Nucl. Instr. Meth. 161 (1979) 383.
5. F. Piuze, to be submitted to Nucl. Instr. Meth.
6. R.W. Warren and J.H. Parker, Phys. Rev. 188 (1962) 2668.
7. E.B. Wagner et al., J. Chem. Phys. 47C (1967) 3138.
8. T.L. Cottrell and I.C. Walker, Trans. Faraday Soc. 63 (1967) 549.
9. A. Breskin et al., Nucl. Instr. Meth. 124 (1975) 189.
10. D. Friedrich et al., Nucl. Instr. Meth. 158C (1979) 81.
11. R. Ford and W.R. Nelson, SLAC 210 UC - 32 June 1978.
12. H.G. Fischer, Nucl. Instr. Meth. 156 (1978) 81.
13. L. Federici et al., Nucl. Instr. Meth. 151 (1978) 103.
14. M. Jezabek, A. Pullia and S. Ragazzi, Private communication.