

THE AUTOMATIC ANALYSIS OF SPARK CHAMBER PICTURES  
USING A FLYING SPOT DIGITISER

P.M. BLACKALL, G.R. MACLEOD and P. ZANELLA  
CERN, Geneva

(presented by P.M. Blackall)

This paper describes an IBM 709/7090 program for the automatic analysis of spark chamber pictures using a flying spot digitiser on-line with the computer. It has been written primarily for the analysis of pictures from a  $\pi^- - p$  elastic scattering experiment run at the CERN PS in January 1963. The program controls the digitiser and carries out all the operations necessary for automatic scanning of the film and measurement and space reconstruction of true elastic scattering events. Whilst a picture is being digitised the central processor time is shared between the program scanning the previous picture and any other compatible independent secondary program.

The program has been constructed from a set of FORTRAN/FAP subroutines of which the majority are independent of the format of the pictures being analysed.

1. Spark chamber experiment

1.1 Experimental arrangement

The experiment was run at the CERN PS in January 1963 by Caldwell et al.<sup>1)</sup>; some 250,000 pictures were taken of which 150,000 showed elastic scattering events. The aim of the experiment is to measure the differential cross-section for  $\pi^- - p$  and  $\pi^+ - p$  elastic scattering at angles between  $7^\circ$  and  $40^\circ$  in the centre-of-mass system. It is also planned to study the behaviour of  $\pi^- - p$  diffraction scattering at very high energies and to search for a possible shrinking of this peak similar to that found with protons.

A schematic diagram of the experimental arrangement is shown in figure 1. Chambers 1, 2, 3 and 4 and the first bending magnet define the path and momentum of the incident pion. Chambers 5, 6, 7 and 8 and the second bending magnet

define the path and momentum of the scattered pion. Chamber 9, which is in fact two 6 gap chambers separated by an air gap, records the path of the recoil proton. All chambers are of parallel plate design.

When the counter selection circuits signal a possible event the camera is triggered and a photograph is taken of all nine spark chambers in two stereoscopic views on a single 24 x 36 mm film frame. This is accomplished by a mirror-lens system for each chamber and view. The two views, called the normal and the stereo, are taken in two perpendicular directions. The normal view is taken from above the chamber and shows a projection in the horizontal plane; the stereo view is taken from the side of the chamber perpendicular to the beam direction and shows a projection in the vertical plane. Cylindrical field lenses placed at the two photographed faces of each chamber ensure that the two views represent orthogonal rather than conical projections of the chambers. The field of both magnets is in the vertical direction.

#### 1.2 Frame format

A typical frame is shown in figure 2. The format has been designed with both manual and automatic scanning in mind. Each view has two fiducial grids of strokes and V-marks. The larger chambers have an extensive array of fiducial marks to allow compensations to be made for distortions in the mirror-lens system. To facilitate the manual scanning, the corresponding views of adjacent pairs of chambers have been placed so that the images of tracks passing through both are co-linear on the film. In the centre of the frame is the data box information which includes the time, date, frame number, roll number and incident pion momentum as well as an array of lights giving a binary representation of the relative frame number. The three large fiducial crosses are used by the scanning program to locate chamber positions within the digitised coordinate system. Figure 3 shows a schematic representation of the chamber view positions on the frame.

A prism mounted in front of one gap in the stereo views of chambers 1 to 8 causes a displacement of the image of any spark in that gap by a distance proportional to its depth in the chamber. This displacement is used to resolve ambiguities arising in correlating tracks in two stereoscopic views when there is more than one track per chamber. The prism position for each chamber is given in table 1.

Table 1

CHAMBER	No. OF GAPS	PRISM GAP No. (ROLL 142)
1	6	5
2	6	5
3	6	5
4	6	4
5	10	8
6	10*	8
7	6+6*	11
8	6*	5
9	6+6*	-

\*)

Chambers 7 and 9 are double chambers with an air gap.

### 1.3 Digitising

The flying spot digitiser (HPD) developed by Hough and Powell<sup>2)</sup> for the analysis of bubble chamber pictures is used to digitise the spark chamber pictures.

A mechanical system causes a spot of light of diameter 15 microns to scan the film in a television-like raster. The scanning lines are parallel to the length of the film and the images of the chamber plates. To scan one line takes 7.5 milliseconds so that for 500 lines/frame (i.e. a scan line separation of 60 to 70 microns) the total measuring time per frame including film advancement is 5 seconds. Whenever a photomultiplier detects the passage of the spot across a dark image its position is digitised and a "spot coordinate" is transmitted to the computer memory via the Direct Data Connection<sup>3)</sup>. This coordinate gives the distance along the scan line of the mid-point of the dark image, and has a word length of 15 bits with a least count equal to 1.6 microns on the film. At the end of every scan line, during the dead time of the spot, a "scan-line coordinate" is transmitted to the computer. This coordinate gives the position of the scan-line within the scanning raster and has a word length of 18 bits with a least count equal to 2.54 microns. The most significant bit is used as a marker bit to distinguish a scan-line coordinate from a spot coordinate.

The computer controls the digitiser by transmitting to the HPD, through the Direct Data Connection, binary bit

patterns corresponding to the control instructions<sup>4)</sup> such as film advance, start digitising etc. Immediately after instructing the HPD to begin digitising a frame, the computer sets up the Direct Data Connection to read the digitisings directly into core storage from the HPD. In order to digitise very faint sparks, a suitable level of digitisation for these pictures has been found to be 4,000 to 5,000 digitisings per picture. Two 5,000 word storage buffers are allocated to contain the digitisings from two frames. While the contents of one buffer are being processed by the scanning program the other buffer is being filled with digitisings from the next frame. Each time the digitising of a new frame is begun the roles of the two storage buffers are interchanged. When the HPD has completed the digitising of a frame it sends an "End of File" signal to the Direct Data Connection. Fault conditions in the HPD may be detected by the program testing the input sense lines<sup>3)</sup>.

## 2. General organisation of the program

### 2.1 Time-sharing

To obtain good definition of the fiducial crosses (12-14 digitisings on each arm) and sparks (2-3 digitisings), a scan line spacing of 60-70 microns is required. This results in a total measuring time of 5 seconds. The complete processing of an event as far as the space reconstruction of all tracks and obtaining an approximation to the space coordinates of the scattering vertex, takes about 5-10 seconds on the IBM 709. (A precise time has not yet been determined due to the large amount of intermediate output taken for testing purposes).

On average only about one frame in two shows a good (i.e. true elastic scattering) event. As it is possible to detect the frames showing bad events or no events in much less than the 5 seconds required by the HPD to digitise a frame, it is desirable to utilise the remaining central processor time. This will be even more imperative when the processing is done on the IBM 7090, since the mechanical speed of the HPD will remain the same whilst the internal speed of the computer is six times faster, and the processing of even the good events will be completed in a time much shorter than the digitising time per frame.

The simplest method of time-sharing the central processor unit (CPU) is to keep in the 709 memory a second program which can run independently of the scanning program. The second program can then be interrupted at will whenever the HPD needs attention, or whenever digitisings are ready to be processed, and serves as a base load to use up all spare CPU time. A natural choice for the second program is SCRAP<sup>5</sup>), the geometrical optimisation and kinematics program for this experiment. SCRAP will take as input the binary output tape from the scanning program, containing reconstructed space coordinates for each good event analysed. Thus as the scanning program is producing a binary output tape of measured good events SCRAP will be reading in a binary output tape from an earlier scanning run.

## 2.2 Main control program

The flow diagram of the main program controlling the two time-sharing subprograms is shown in figure 4. The scanning program is referred to as CALC 1. and the kinematics program, SCRAP, is referred to as CALC 2, CALC 1 and CALC 2 can either time-share together or one of them can run independently.

Sense switch 3 controls the entry of CALC 1. If the HPD is not operational at the time of starting the run, the program can detect this from the sense input lines and will print on-line an interruption procedure to be used when the HPD is ready. It proceeds to CALC 2.

CALC 2 is controlled by sense switch 2. The program cycles once per event through the main control loop permitting both temporary and final termination. Sense switch 1 controls the final termination of both CALC 1 and CALC 2.

The programs contained within the broken-line rectangle are interrupted at the end of the measurement of the first and succeeding frames and control transfers to TRAP, the control program for data channel trap interruption, which initiates the measurement of the next frame and enters CALC 1 to scan the current frame.

There are two possible kinds of data channel interrupt. An "End of File" interrupt which occurs at the end of a measurement and a "buffer overflow" interrupt which occurs when 5,000 digitisings have been read into core storage.

An additional interrupt, the direct data interrupt, is used for communication from the HPD operator to the computer to indicate either a new roll of film has been loaded and the HPD is ready or the HPD is operational again after a breakdown.

### 2.3 Shared subroutines

As CALC 1 and CALC 2 are written in FORTRAN/FAP and are intended to occupy together 32,000 words of core storage it is desirable that only one copy of all the common subroutines be in core storage. However, an interrupt may occur whilst the second program is using one of these stored subroutines, and the scanning program may, after this interrupt, want to use the same subroutine. It is necessary therefore to arrange that if an interrupt occurs during execution of one of these routines the routine should be completed before the scanning program is entered after the interrupt.

The following FORTRAN II library routines have been modified to allow them to be used by two independent programs.

I/O routines: BST, EFT, RWT, IOB, IOH

Arithmetic routines: XP1, XP2, XP3, XPF, LOG, ATN, SCN, TNH, SQR

Other routines: FPT, CLOCK (CERN installation routine)

The modification involves the use of four indicator flags situated in the first four locations of COMMON storage, listed in Table 2.

Table 2

Octal location	Name	Contents	Purpose If Non-Zero:
77461	DDIFLG	Non Zero/Zero	Indicates a direct data interrupt has occurred
77460	SUBFLG	Non Zero/Zero	Indicates a shared subroutine has been entered
77457	TRPFLG	Non Zero/Zero	Indicates a data channel interrupt has occurred
77456	FPTFLG	Non Zero/Zero	Indicates a floating point trap has occurred

The entry of any shared subroutine sets SUBFLG non-zero. Should an interrupt occur during execution of one of the shared subroutines, the state of SUBFLG indicates this to the interrupt routine (see next paragraph, TRAP) which can then arrange for the subroutine to be completed before attending to the interrupt condition. At the point of exit it resets SUBFLG to zero but first tests whether the flags DDIFLG and TRPFLG are non-zero. If either flag is non-zero, showing that an interrupt had occurred during the execution of the routine, the address of the point of interrupt is set to the address of the exit point of the shared subroutine, and a transfer is made to the appropriate interrupt program.

#### 2.4 TRAP program

The flow diagram of TRAP is shown in figure 5. TRAP is entered either by trapping on the End of File signal at the end of a measurement or by trapping on the completion of a channel command whilst measuring -- this corresponds to the allocated core storage buffer running full.

TRAP ensures that the following requirements are met:

1. That the HPD is measuring whenever possible.
2. That the last digitised frame (the current frame) is processed whilst the HPD digitises the next frame.
3. That any spare CPU time is utilised by returning to the interrupted program, CALC 2.

TRAP initially sets TRPFLG non-zero. TRPFLG and SUBFLG are tested in turn to see whether any outstanding floating point trap or shared subroutine entry requires completion. These are completed if necessary and TRPFLG is reset to zero preventing the shared subroutines re-entering again at the beginning of TRAP if used within TRAP. All registers are saved and sense switch 1 is tested for termination of the run. If termination is not required the type of trap is examined. At the end of every measurement a test is made for a blank frame; this is detected if the total number of digitisings, KDIGIT, is less than a parameter KMIND. If the frame is not blank, the storage buffer addresses are switched and the next measurement is initiated, provided the end of the roll has not been reached. CALC 1 is entered to process the current frame. Upon exit the arithmetic registers are restored, channel traps are restored and a return is made to the point of interrupt.

If a trap on buffer overflow occurs, a search is made within the last 50 digitisings for a scan line coordinate which is compared with a parameter KMINX. If it is equal to or greater than KMINX, enough of the frame has been digitised for the scanning program to attempt to process it. Otherwise the frame is rejected as un-measurable.

### 3. The automatic scanning program

#### 3.1 Coordinate system

The digitisings are made in an arbitrary cartesian frame of reference defined by the HPD. The fiducial grids photographed on each view of each chamber define points and a fiducial plane whose coordinates in space are known from measurements made during the experiment. For each roll of film, measurements are made on the first frame, the calibration frame, using a digitised projector to determine the relative positions of the images of fiducial crosses and the fiducial grids of the various chambers. This information is read from cards by the program whenever a new film is mounted on the HPD.

The HPD film transport positions each frame with an uncertainty of 0.5 mm. For each frame digitised, the program searches for digitisings within certain pre-determined regions for the fiducial crosses. These regions are large (5 mm  $\times$  2.5 mm) enough to contain the crosses even allowing for the uncertainty in the film positioning.

Once the positions, in the HPD reference frame, of two of the three fiducial crosses have been found, the program determines a transformation deduced from the measurements of the calibration frame, which allows it to define for each frame:

- a) exactly where on the frame in HPD coordinates the chamber views lie, and
- b) the transformation from HPD coordinates to space coordinates for each chamber.

The relative positions on the film of the chamber images and the fiducial crosses gradually change over a period of several hours due to instabilities in the mirror-lens system. Measurements showed that over the period of 1-2 hours represented by one roll of film these changes are smaller than the errors of measurement;



hence one calibration frame is measured for each roll of film.

### 3.2 Scanning criteria

An elastic scattering event is recognised by the following geometrical criteria.

1. There is only one incident particle and its track must not be inclined more than  $1^\circ$  with the axis of any of the beam chambers 1, 2, 3, 4. However one of the four chambers may also contain a second track. The incident track must be visible in both views of all the beam chambers.
2. The scattered particle must pass through the correct region of chamber 8 for its incident momentum; its track must not be inclined more than  $10^\circ$  with the chamber axis. The scattered particle track must be visible in both views of chambers 5, 6, 7, 8.
3. Chamber 9 must contain at least one recoil proton track visible in both views coming from the target volume.
4. The incident particle track, the scattered particle track and the recoil proton track must all extrapolate to a scattering vertex within the target volume.

For events satisfying these geometrical criteria, the program outputs on a binary magnetic tape space coordinates for a point on the appropriate track in each of chambers 1 to 8, two points on the track in chamber 9, and approximate space coordinates for the scattering vertex.

### 3.3 General flow

As a frame is stored as a one dimensional array of digitisings it is desirable to minimise any repetitive scanning of the array. Thus the logical order of operations given by the geometrical criteria has been modified to take into account the positions of chambers on the film. After scanning the region of a chamber or of a fiducial cross, the position in the array corresponding to the end of the search region is saved. These positions are subsequently used to move from chamber to chamber across the film without any further repetitive scanning.

The sequence of operations carried out for each frame showing an elastic scattering event is listed below. If at any point in this sequence the necessary criteria are not met, the frame is rejected as not containing an event of interest. An appropriate error output is made, and control passed to the second program CALC 2.

1. Search for the fiducial crosses.
2. Calculate the transformation coefficients from the calibration reference frame to that of the HPD.
3. Search for a track of a scattered particle in both views of chamber 7.
4. Search for a track of an incident particle in both views of chamber 1.
5. Extrapolate within the HPD reference system the track of the scattered particle found in chamber 7 into both views of chamber 8 and search for its continuation. (Extrapolating the particle in this direction is usually more successful than the reverse direction as the track in chamber 7 is better defined viz. 12 sparks as against 6 sparks).
6. Check that the track is in the correct region of chamber 8 for its incident momentum and that its inclination with the chamber axis is less than  $10^\circ$ .
7. Search for a track of an incident particle in both views of chamber 2.
8. Test if the tracks in both views of chambers 1 and 2 correspond to the same incident particle.
9. Search for a track of a recoil proton coming from the target volume in both views of chamber 9.
10. Extrapolate the track of the scattered particle found in chamber 7 into the stereo view of chamber 6 and search for its continuation. The bending magnets have negligible effect in the vertical plane.
11. Search in the normal view of chamber 6 for the correlated track of that found in the stereo view.
12. Extrapolate the track of the scattered particle found in chamber 6 into both views of chamber 5 and search for its continuation.
13. Extrapolate the track of the incident particle found in chamber 2 into the stereo view of chamber 3.

14. Search in the normal view of chamber 3 for the correlated track of that found in the stereo view.
15. Search for a track of an incident particle in both views of chamber 4.
16. Test if the tracks in both views of chambers 3 and 4 correspond to the same incident particle.
17. Reconstruct into space all recognised tracks and test that the incident particle track, the scattered particle track and the recoil proton track extrapolate to a scattering vertex within the target volume.

One point on the track in each chamber is reconstructed into space. This point is the intersection of the track with one of the fiducial planes of the chamber. The position of this fiducial plane is known in space and its image is indicated in both views by a fiducial grid. For each view the intersection of the track image with the fiducial grid line is transformed to space by linearly interpolating between the two nearest chamber fiducials. The intersections obtained from both views give two of the space coordinates; the third coordinate, that of the fiducial plane, is known.

### 3.4 Basic subroutines

There are four basic subroutines:

1. FIDUC A subroutine for finding a fiducial cross
2. SPARK A subroutine for finding sparks in a view
3. TRACK A subroutine for finding linear tracks from sparks within a view
4. CORREL A subroutine for correlating tracks in two stereoscopic views

#### 3.4.1 FIDUC subroutine

The input data to this routine are the coordinates of a rectangular searching region and the tangents of the angles made by the two arms of the cross and the scan line direction. Figure 6 shows a plot of the digitisings obtained from a fiducial cross; the rectangular region represents approximately the search region used (2.5 mm x 5 mm on the film) where the long dimension is in the direction of film motion.

The subroutine searches within the boundaries of the rectangular region for those digitisings corresponding to a fiducial cross. The fiducial is recognised by the upper arms converging to within a distance of 400 microns. Once this condition is satisfied the subroutine searches for digitisings on the lower arms. The end of the search region terminates the procedure and a least squares fit is made to the digitisings of both arms to give the intersection point.

#### 3.4.2 SPARK subroutine

The input data to this routine are the number of gaps and the coordinate positions of each gap. The subroutine assumes that the plates of the chamber are parallel to the scan direction. SPARK searches independently within each gap to associate digitisings from one scan line to the next. Digitisings must differ by less than half a spark width (40 microns) to be associated to the same spark.

If there are at least two digitisings per spark length, a spark is recognised with coordinates of the mean of the digitisings and of the mid-point of the gap. Figures 7, 8 and 9 show plots of digitisings of tracks from figure 2.

#### 3.4.3 TRACK subroutine

The subroutine uses the following algorithm for finding linear tracks:

1. Ignoring gaps with no sparks, select two gaps which first contain the least number of sparks and second are most distant from one another.
2. Generate all possible tracks from the combinations of the sparks from one gap with those of the other, which fulfill the conditions of track slope for the chamber. These spark combinations are termed "generating pairs".
3. For each generating pair of sparks calculate the intercept of the line joining them on the remaining gaps.
4. Within a region of one spark width (80 microns on the film) either side of the intercept select the nearest spark to the intercept for each gap.

5. Accept the track if the total number of sparks selected is greater than the threshold for the chamber (usually equal to half the total number of gaps).
6. If the track is accepted cancel the accepted sparks from each gap.

If no track is found from the generating pairs of the two selected gaps, one gap is held selected whilst the next best possibility is chosen for the other. When all possibilities have been exhausted for the second gap, the sparks from the first gap are erased. This erasure together with the cancellation of accepted sparks ensures convergence of the procedure.

#### 3.4.4 CORREL subroutine

It was originally planned to correlate tracks in the two stereoscopic views using the prism displacement effect. Unfortunately this feature was not very reliable due either to the non-firing of the gap containing the prism or to the displacement being outside the field of view. It was therefore decided to correlate tracks by their spark patterns and to use the displacement information only when this method failed.

The correlation of tracks by spark patterns is based on the efficiencies of the chambers. Generally when there is more than one track in a chamber not all gaps fire for all tracks. Moreover the presence or absence of a spark in a gap is observed in both stereoscopic views. A track can be characterised by a binary pattern where each bit corresponds to a gap and a 1 represents the presence of a spark and a 0 the absence of a spark. Thus ideally for two tracks to be correlated the binary patterns will be identical. In actual practice very thin weak sparks can sometimes be digitised by the HPD in one view and not in the others. A correlation of tracks is therefore accepted if there are not more than two inconsistencies in the binary patterns.

#### 3.5 Storage requirements

A total of 23,000 words are at present used by the scanning program, including 10,000 for the input buffers and 3,000 for library routines. With removal of various printing and debugging routines at present included, some 10,000 to 11,000 words will be available for the CALC 2 program, excluding its library routines which will be shared with those already used in the scanning program.

#### 4. Preliminary results

Tests on the complete program have been under way since the end of June 1963, and results so far obtained are given below.

The on-line control of the HPD, and the time-sharing features of the program operate satisfactorily. Tests have been carried out on film previously measured by hand on digitised scanning tables and the results from the two methods compared. A total of 390 pictures have been digitised, known to contain 187 elastic scattering events. The program has recognised 136 i.e. 73% of these. It has therefore rejected 27% of the scattering events which it should have found. On the other hand it has not accepted any events at all which should have been rejected.

The incorrect rejections fall into three categories:

- a) Errors in track recognition when two tracks are very close to one another.
- b) Incorrect track extrapolation from one chamber to another.
- c) Failure to correlate the correct tracks between two stereo views when there is more than one track in a chamber.

Several modifications are being made to reduce the number of these rejects.

The first two categories will be reduced shortly when the HPD track centre circuit is changed. At present if a spark is wider than 30 microns the digitising does not correspond to the centre of the spark but to a position 15 to 20 microns from one edge. Thus for a track containing both fat and thin sparks (a condition often seen) an error is introduced into the measurement of spark positions. For closely adjacent tracks this may cause the wrong sparks to be grouped into a track. For a single track an error in slope is introduced, which when magnified by extrapolation to the next chamber can cause the continuation of the track in this chamber to be completely missed.

The extrapolation of a track from a view of a chamber to the corresponding view of an adjacent chamber is made within the HPD reference frame, neglecting the small variations in chamber demagnifications. A correction to the alignment of the two chamber axes is obtained from the relative positions of chamber fiducials. A complete transformation into a common reference frame for both chambers will be made to improve track extrapolation.

A variety of possibilities also exist for logical modifications to the program which will be explored; for example the order of selection of chambers can be changed, tracks can be followed in the reverse direction, difficult track correlations can be avoided by following the correlated tracks found in an adjacent chamber into both views of the chamber, etc.

### References

1. D.O. Caldwell, B. Elsner, D. Harting, A.C. Helmholtz, W.C. Middelkoop, B. Zacharov, P. Dalpiaz, G. Giacconelli, L. Monari, L.W. Jones, " $\pi$  - p, p - p scattering at 8, 12, 18 GeV/c", to be published in Proceedings of the International Conference on Elementary Particles, Siena, 30 September - 5 October 1963.
2. P.V.C. Hough and B.W. Powell, "A method for faster analysis of bubble chamber photographs". Proceedings of an International Conference on Instrumentation for High Energy Physics, Berkeley, p. 242, September 12 - 14, 1960, New York.
3. IBM Special Systems Features Bulletin, "Direct Data Connection for IBM 709", RPQ 80979.
4. B.W. Evershed, "On-line computer control of the HPD", CERN 63-21, 6 June 1963.
5. B. Zacharov, unpublished work.

Figure captions

- Fig. 1 Schematic Diagram of  $\pi^{\pm} - p$  elastic scattering experiment.
- Fig. 2 Typical picture showing positions of chamber views.
- Fig. 3 Schematic Diagram of frame format.
- Fig. 4 Main control Program.
- Fig. 5 Data Channel Trap Program.
- Fig. 6 Digitisings of Fiducial cross No. 2 of figure 2.
- Fig. 7 Digitisings of an inclined track. View 9/1 of figure 2.
- Fig. 8 Digitisings of a track with a spurious spark view 7/1 of figure 2.
- Fig. 9 Digitisings of a track with a displaced spark view 7/2 of figure 2.



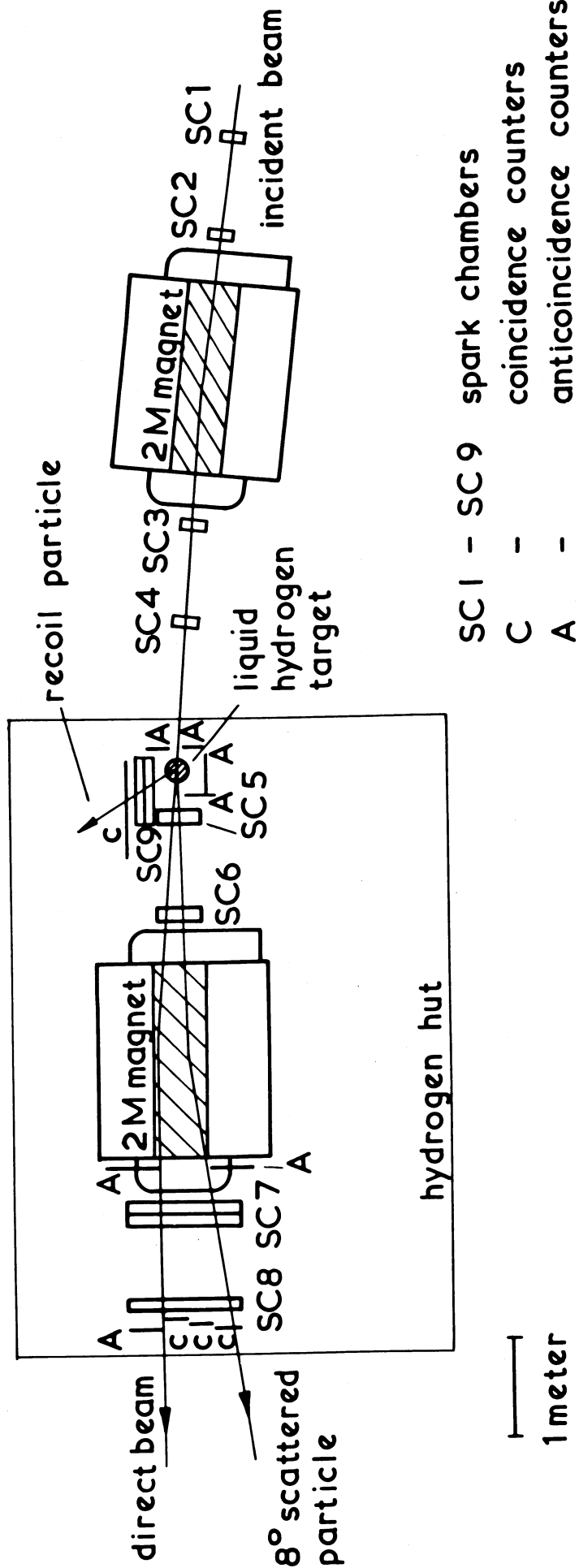

Figure 1

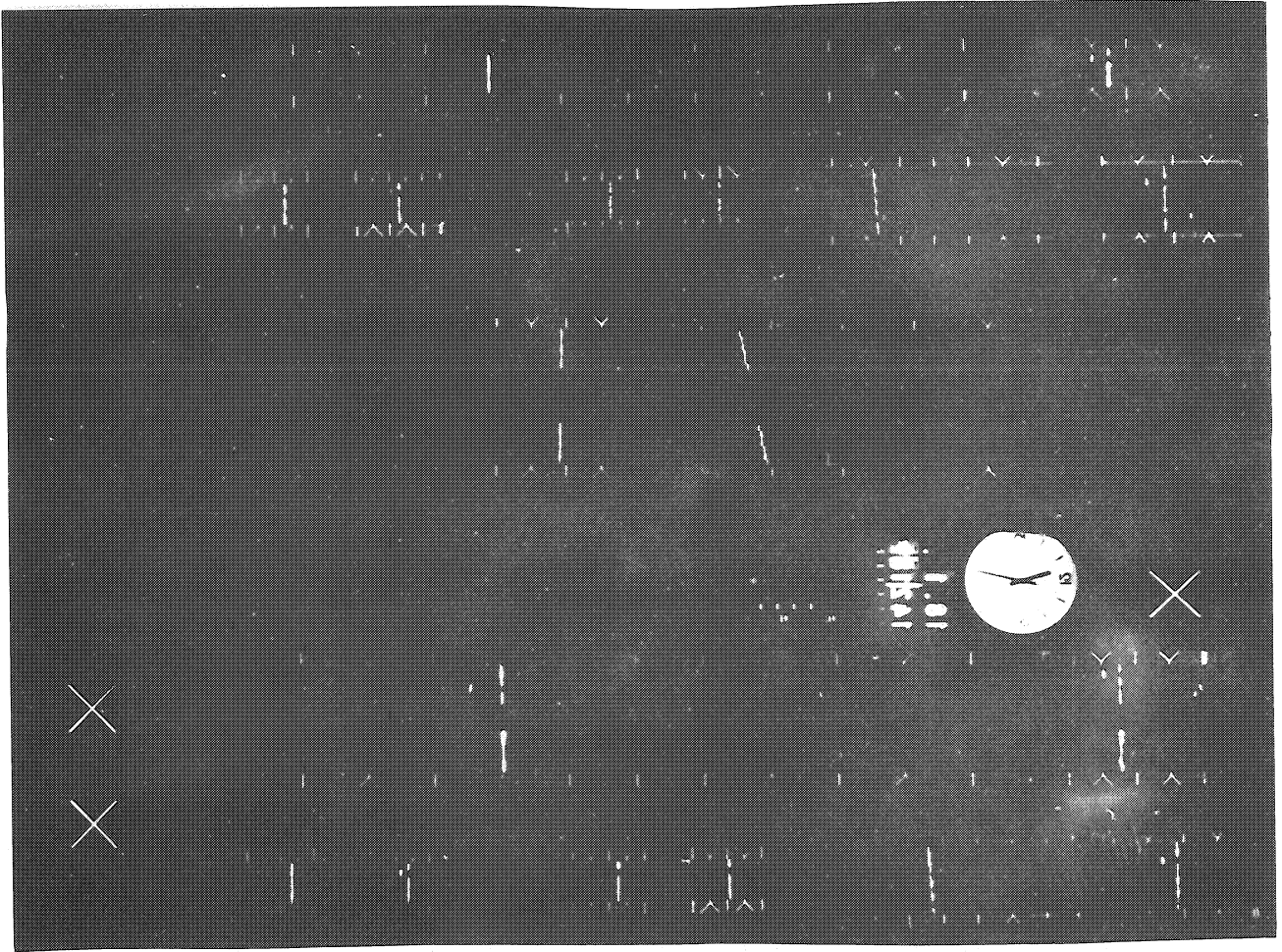

Figure 2

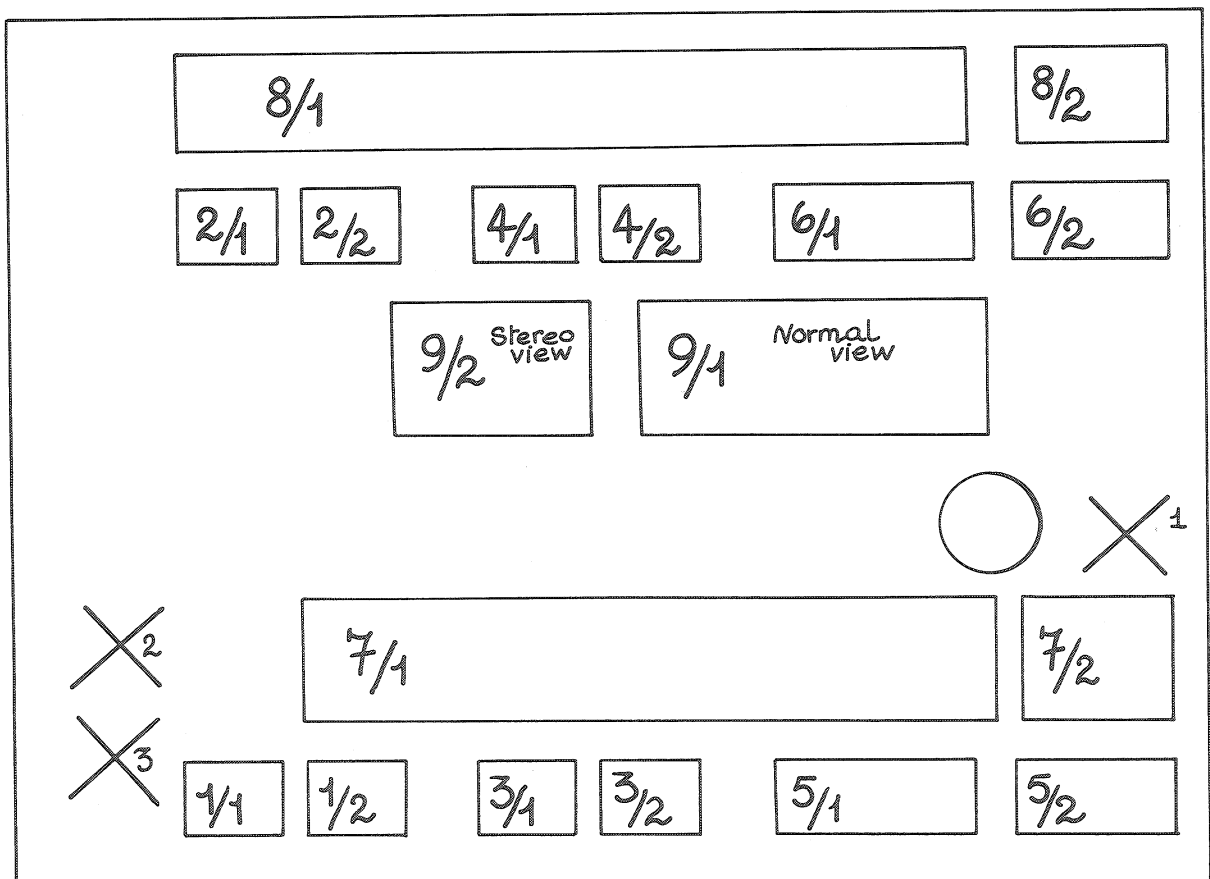

Figure 3

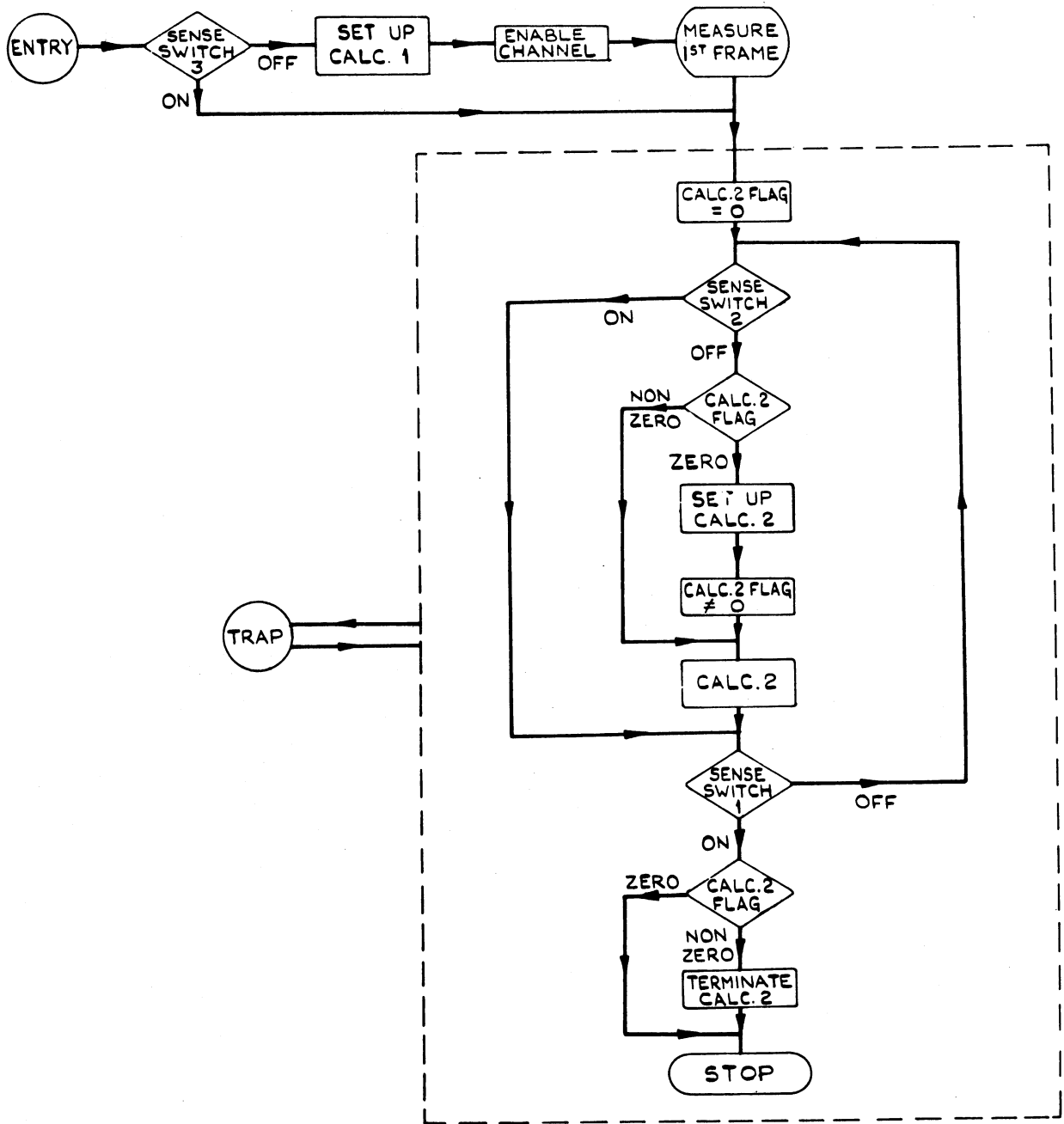

Figure 4

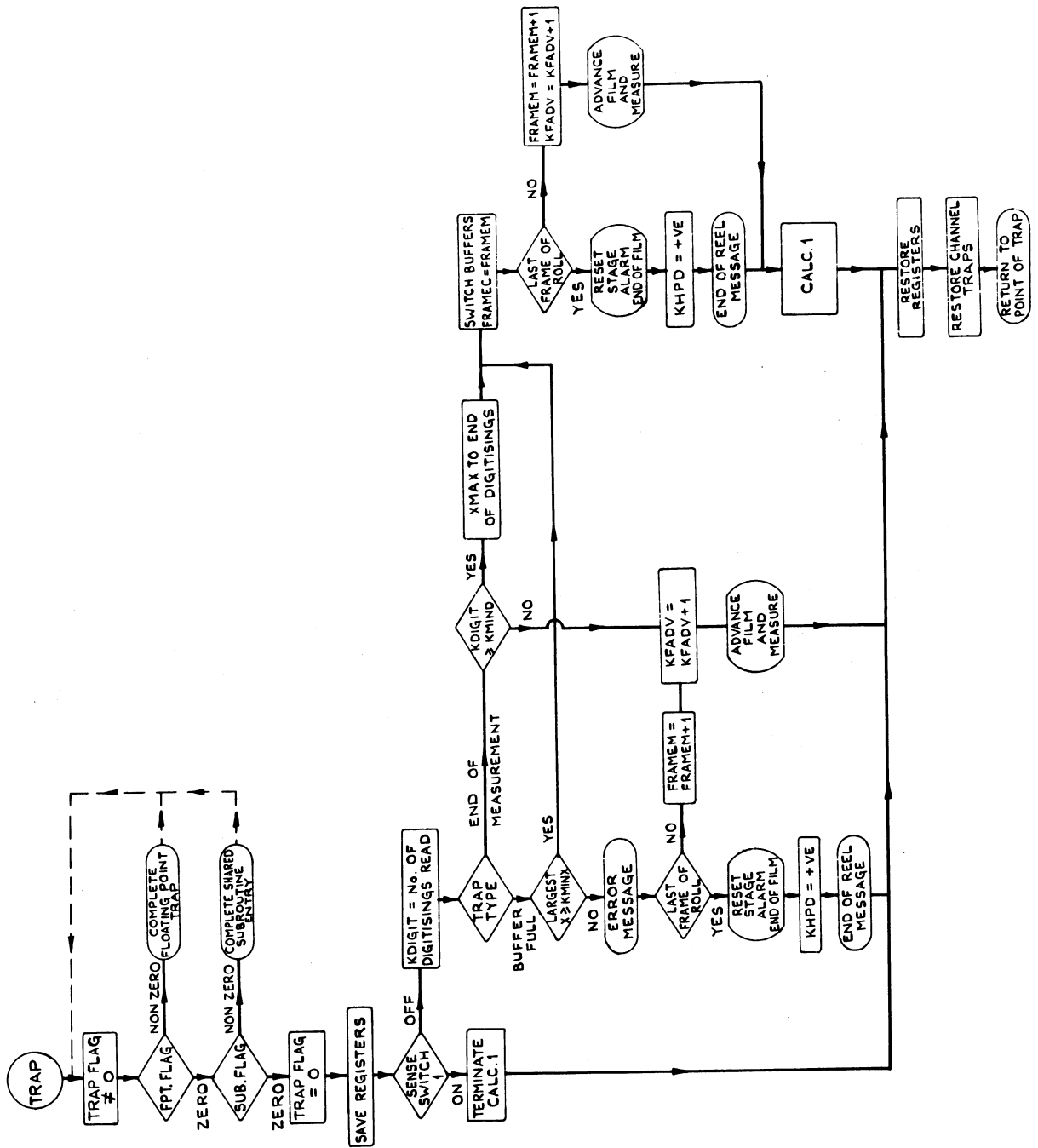
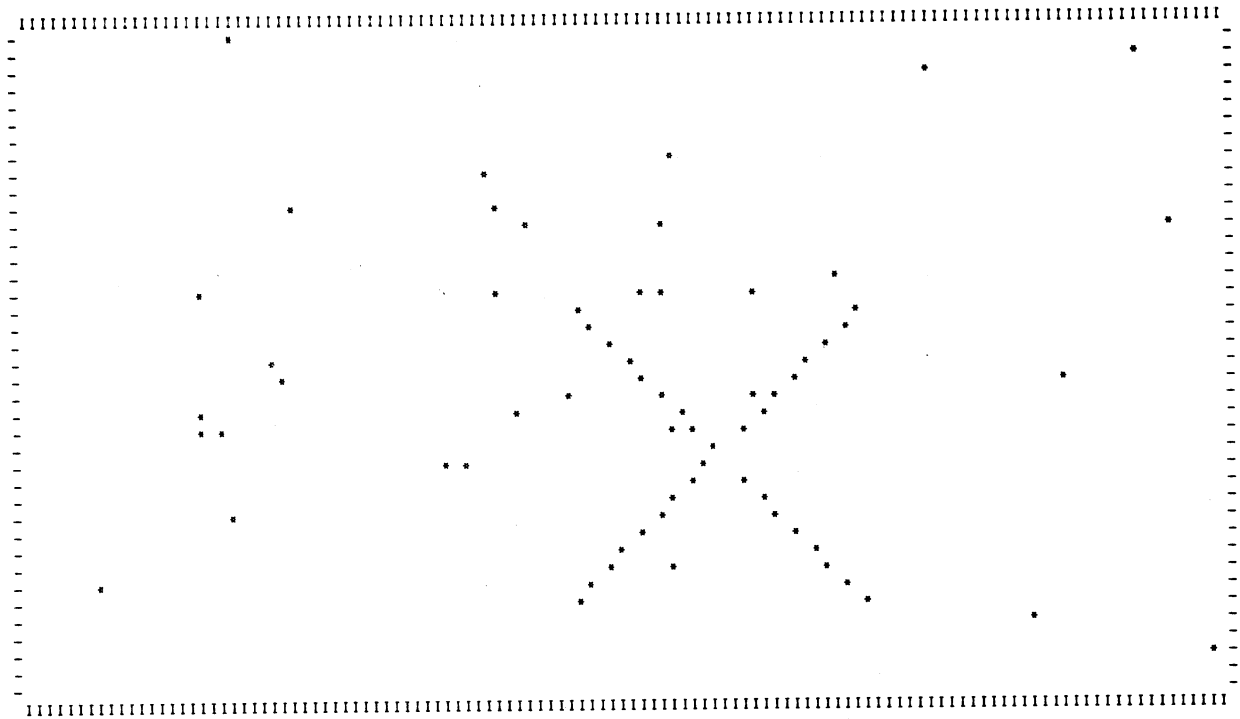
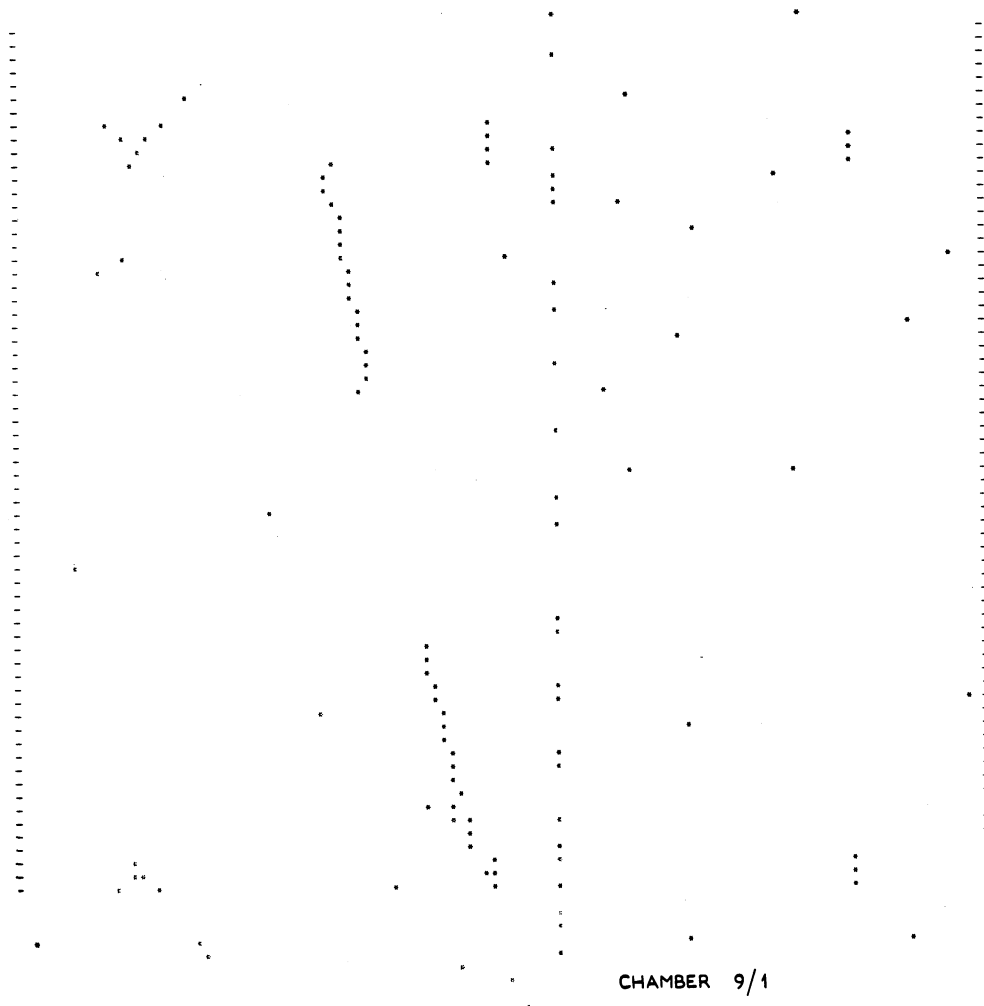

Figure 5



FIDUCIAL CROSS 2

Figure 6



CHAMBER 9/1

Figure 7

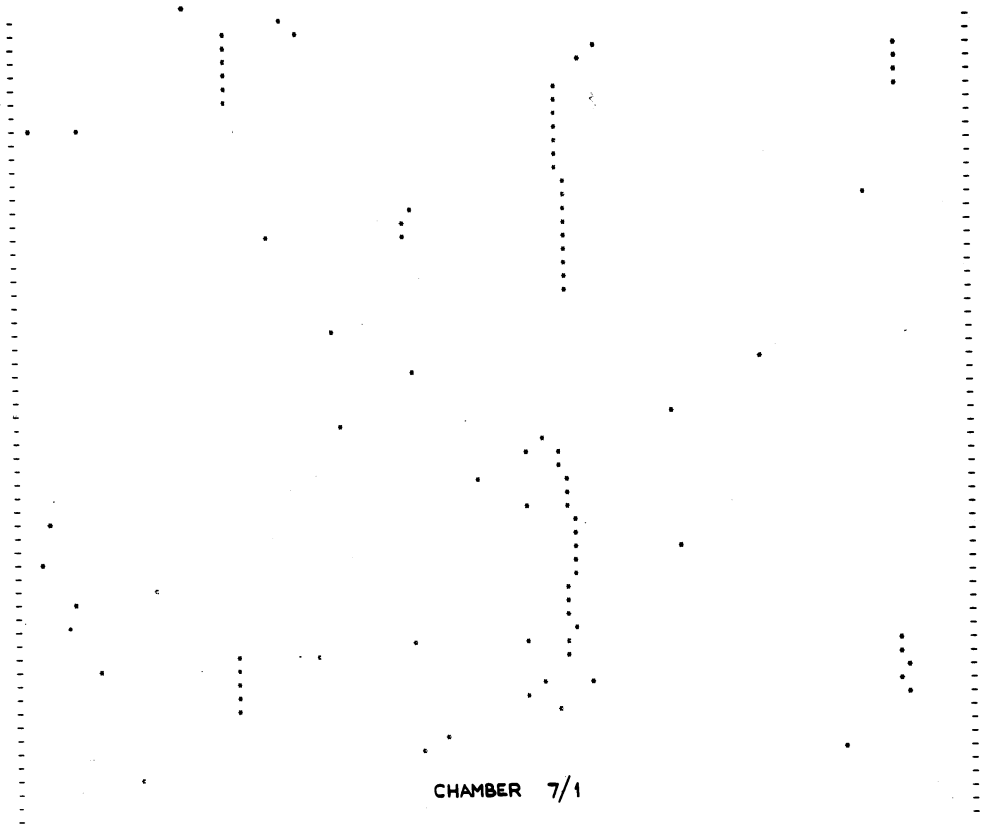

CHAMBER 7/1

Figure 8

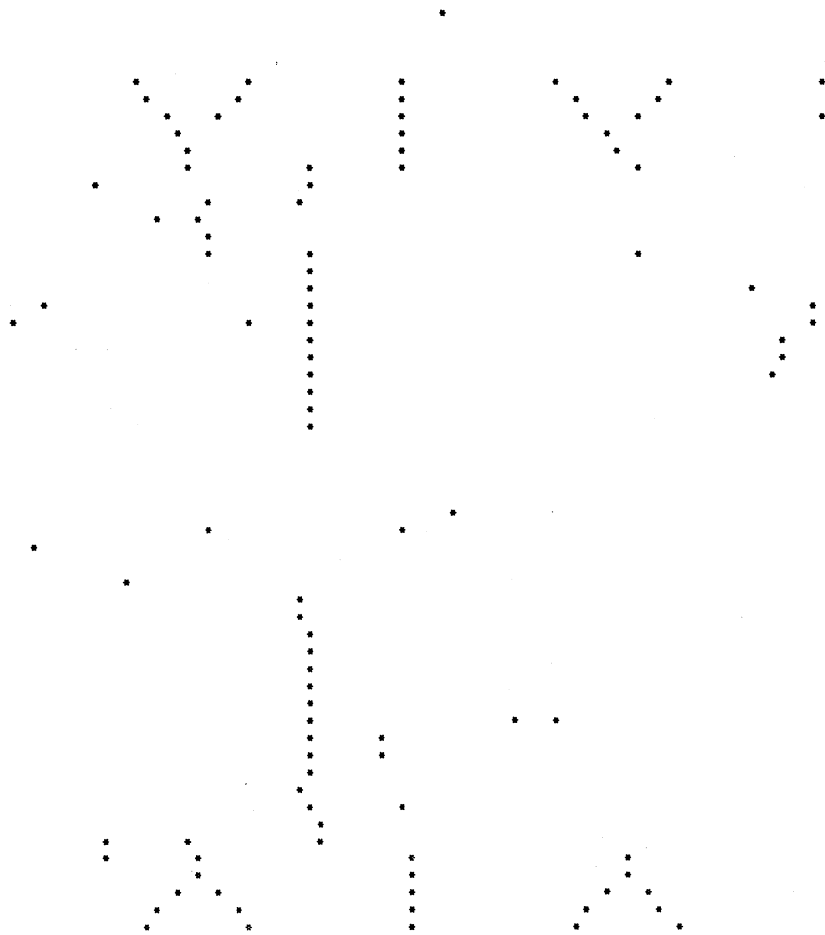

CHAMBER 7/2

Figure 9

DISCUSSION

TYCKO: What is the road width ?

BLACKALL: The road width is about 160 microns, i.e. about twice the width of a spark.

BAKER: What changes have to be made to the HPD hardware to process spark chamber pictures and how long does it take ?

POWELL: Not very much. It means taking off one film transport and putting on another, which is easy on our HPD. You then have to re-focus the track channel. The last time we did it, it was at most half a day before we were ready again.

BAKER: Do you position the film for measurement by means of the perforations ?

BLACKALL: Yes.

BAKER: When you are fitting a track to the sparks, what point on the track do you take ?

BLACKALL: In the direction parallel to the plate we take the average of the digitisings, and in the other direction we take the mid-point of the gap.

BAKER: Have you tried to take pictures of a general grid, and then digitise it to find out what distortions you had during the run - e.g. movements of the mirrors, etc.

MACLEOD: We measure a calibration frame once per roll and we find that the reproducibility is better than the precision of our digitisings. The fiducials are measured on the film to something like  $10\mu$ .

POWELL: Is there any danger of losing digitisations on the track due to premature rejection when the program tries an incorrect pair ?

BLACKALL: A spark is rejected only after all possibilities of forming tracks with other sparks have been tried unsuccessfully.