

ORBIT STUDIES FOR A 72-INCH CYCLOTRON WITH LARGE SPIRAL ANGLE

L.W. Baumhoff, F.P. Brady, G.A. Carlson,
J.A. Jungerman, and J.A. McCray
University of California, Davis
(Presented by J.A. Jungerman)

The object of the orbit studies reported below was to maximize the performance of the 72" magnet of the Crocker 60" cyclotron for use in a sector-focusing variable-energy accelerator. Since the axial focusing forces increase strongly with the spiral angle for a given flutter, high spiral angles allow low flutter amplitudes with adequate axial focusing. Low flutter, in turn, allow a smaller average gap, which permits higher magnet efficiencies. The average magnetic field can be higher for a given magnetic field in the hills, and the average radius to which particles can be accelerated is increased. A schematic design is shown in Fig. 1.

As has been pointed out by many workers¹⁾, a high spiral angle restricts radial stability and forces non-linear resonances. The purpose of this study was, therefore, to determine how serious these objections would be for the energies and particles to be accelerated.

To provide a realistic magnetic field, an approximate 1/4 scale model was constructed. Archimedian spirals attaining an angle of 70° at extraction radius (32") were employed with iron added in the valleys to isochronize approximately protons of 80 MeV at extraction radius. The geometry is shown in Fig. 2. Model measurements of the field produced by concentric trimming coils were also made in the outer radial region. A linear program was used to optimize coil settings. Fig. 3 shows the average field from the iron alone and the calculated field from the linear program. The isochronous field shown is that provided by the analysis of the iron field by the Oak Ridge Code on the IBM 7090.

The first question to be answered is that of adequate radial stability in the isochronous region. A code was written to integrate the equation of motion in the median plane for a magnetic field of three-fold symmetry with sinusoidal flutter and Archimedian spiral. A radial phase plane diagram at a hill-center azimuth for the case of 84 MeV protons at 28 in. and no first harmonic is shown in Fig. 4. The stability limit was taken as the radius of the circle inscribed in the largest stable region and centered at the equilibrium orbit. The parameter α is defined by the equation $p_r = p \sin \alpha$, where p is the particle momentum. Stability limits as a function of radius and spiral angle for both protons and N^{4+} ions were obtained from similar diagram and compared with the analytical values of Smith and Garren²⁾. The comparison for protons with 70° spiral angle is shown in Fig. 5. The flutter

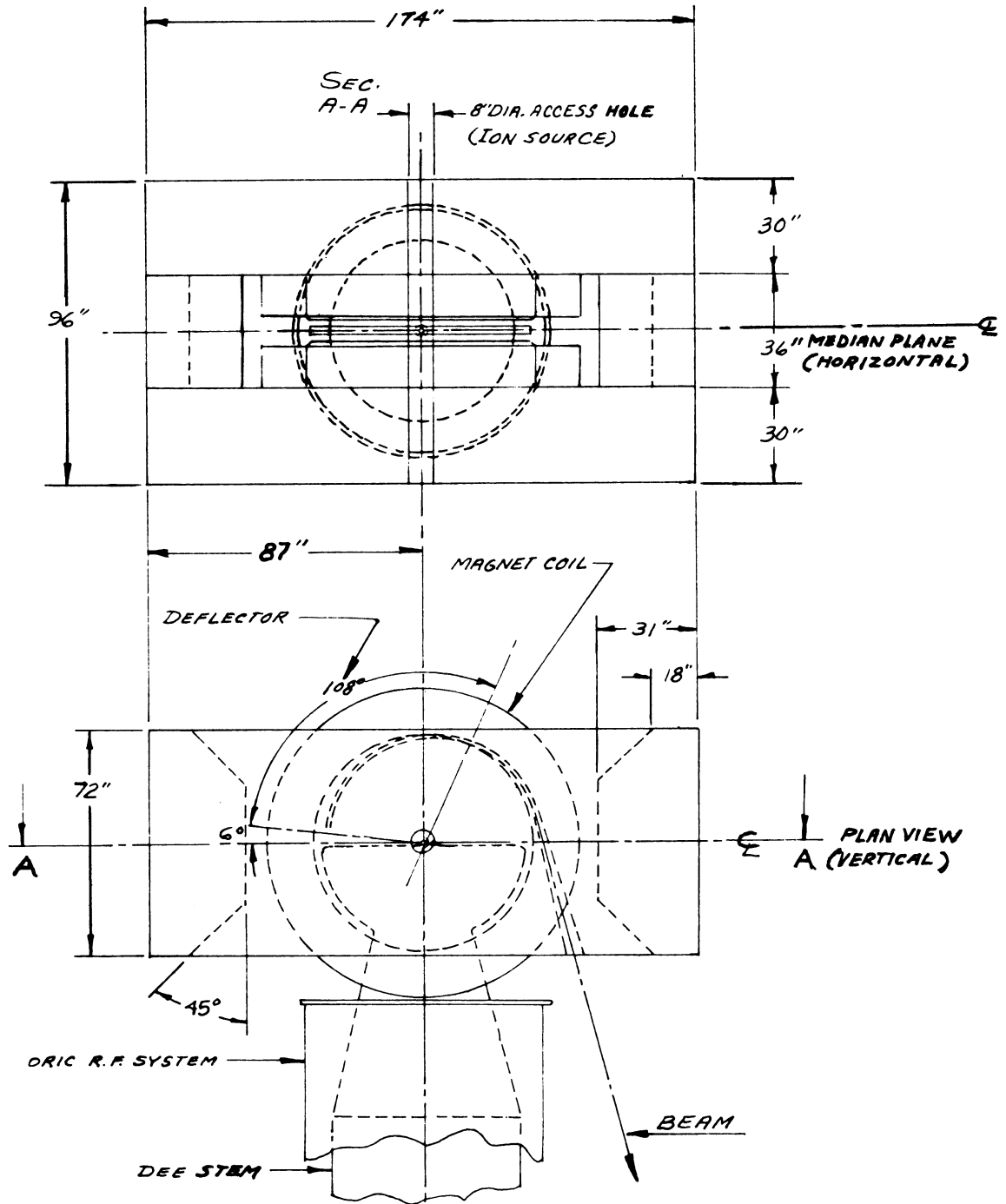

Fig. 1 The 72" cyclotron magnet.

amplitude was constant at 0.155.

A first-harmonic contribution to the magnetic field was introduced to study its effect on the radial stability limits. For the case of protons at 28 in., with a 70° spiral, a 10 gauss first harmonic decreased the radial stability limit to 75% of its no first harmonic value; for a 75° spiral, the radial stability limit was

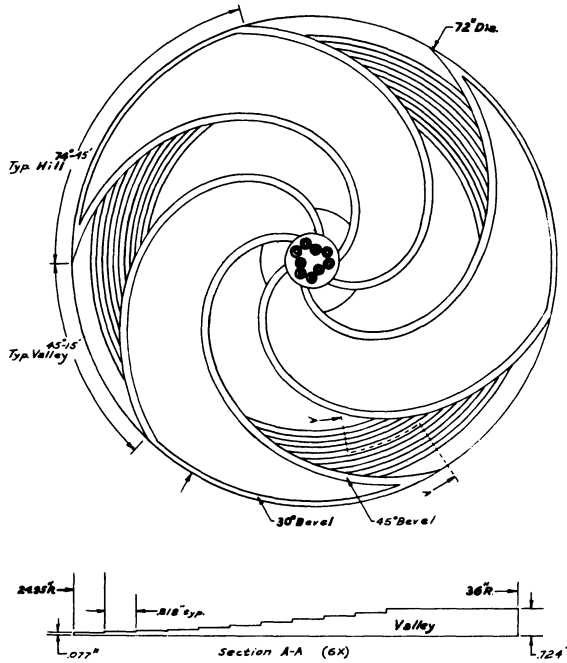

Fig. 2 Pole tip geometry for the 72" cyclotron.

decreased to 64% of its no first harmonic value. The effect is more serious for N^{4+} . At 28 in. with 70° spiral, a 10 gauss first harmonic decreased the stability limit from 0.6 in. to 0.3 in. The first harmonic amplitude which would give rise to zero radial stability was calculated for this case from the analytical formula of Hagedoorn and Verster³⁾ and was found to be 15 gauss. Since the results for N^{4+} with first harmonic seem to be rather marginal, it may be necessary to increase the flutter at inner radii to achieve adequate radial stability for N^{4+} particles.

Fig. 6 summarizes the radial stability limits in the isochronous region for the magnetic fields used in the extraction

studies reported below. In this case the flutter amplitude was adjusted so that $v_z = 0.1$ for the various spiral angles and radii.

Extraction of a beam of 100 MeV protons is a serious consideration. Since the high spiral angles force non-linear resonances, resonant extraction would give very poor beam quality. Fortunately, the favorable experience in efficient electrostatic extraction of particles from the Berkeley 88" cyclotron encourages possible extension of that technology. Studies made by M.J. Knox and I.E. McCarthy with the CYBOUT code show that a deflector length of 108° would deflect 100 MeV protons with 107 kV/cm, with an efficiency of 40%. To achieve this performance it is essential to begin deflection at 32" radius after passage through the 3/3 and Walkinshaw resonances.

For investigating beam properties during passage from the isochronous region to the electrostatic deflector a code was written for the IBM 7090 computer which integrates the axial and radial equations of motion. Magnetic fields off the median plane were linearized in the axial variable. The radial dependence of the average magnetic field was taken to be that of the calculated field of the 72" model shown in Fig. 3. A ninth-order polynomial

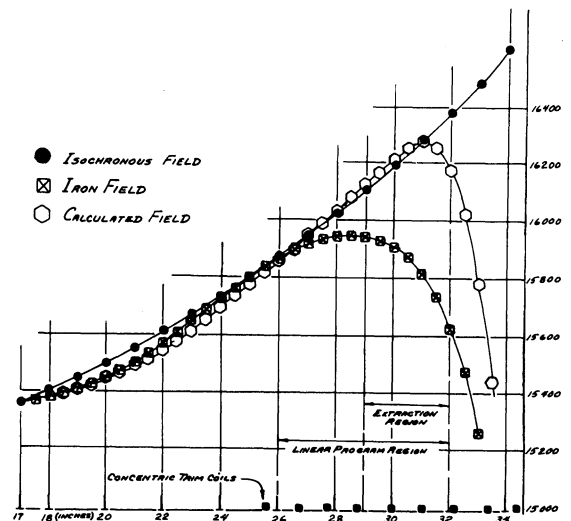

Fig. 3 Radial profile for 80 MeV H^+ beam.

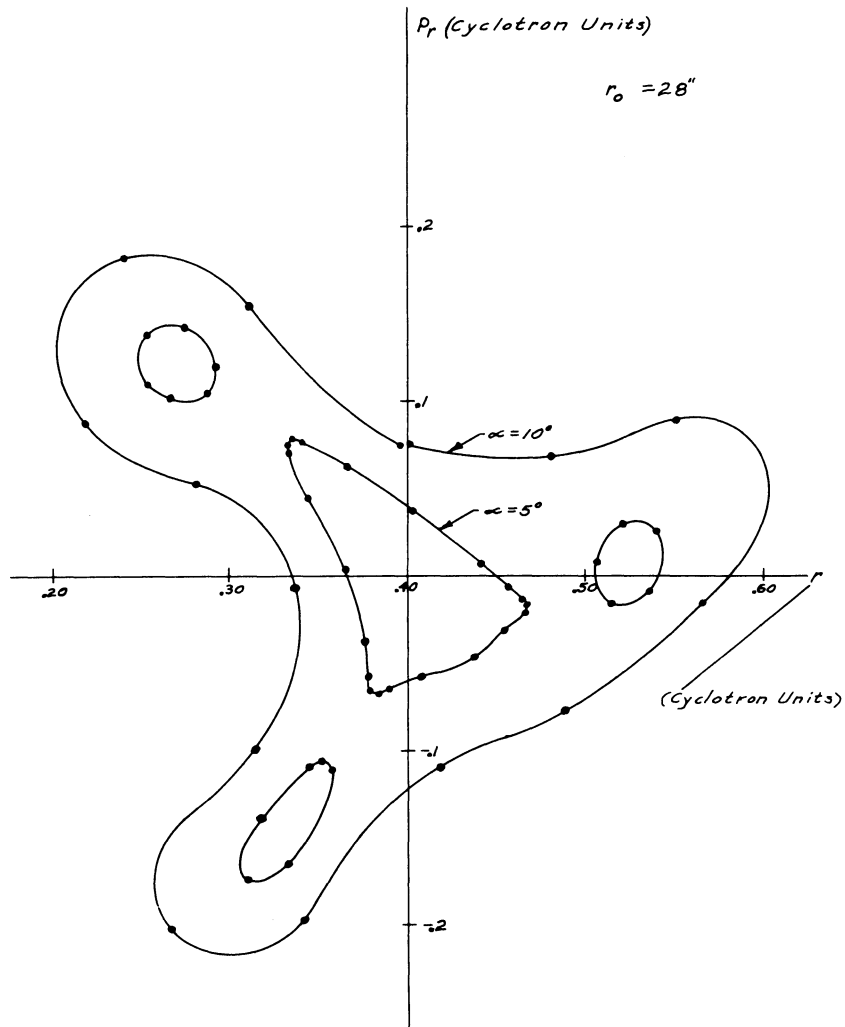

Fig. 4 Radial phase-plane diagram.

was fitted to 30 points in the 26 to 33.75 in. region. The fit was good to one part in 10^4 at the measured points. Since terms driving the non-linear resonances are of order of magnitude $\mu^n \xi^n / n!$ for order n , these quantities were calculated for two values of radial oscillation amplitude by means of the above polynomial. The results are shown in Fig. 7 and 8. Thus, terms of at least 3rd order are important from radial derivatives alone in this region, and further non-linear effects will result from the contribution of the flutter and spiral angle.

A constant sinusoidal flutter for a given Archimedian spiral angle was used in computer calculations with the above polynomial for the radial dependence of the average field. For spiral angles of 55° , 70° , and 75° , at 32" radius, the flutter amplitude used was 0.304, 0.170, and 0.128 respectively.

Fig. 9 shows the radial phase plots resulting from integration of a grid of initial conditions of radial oscillation from 29 to 32" radius (deflector entrance)

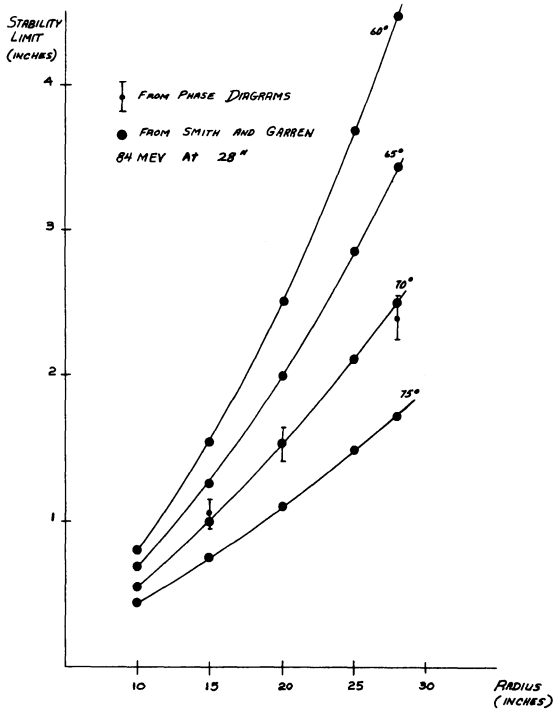

Fig. 5 Isochronous field radial stability limits (protons)

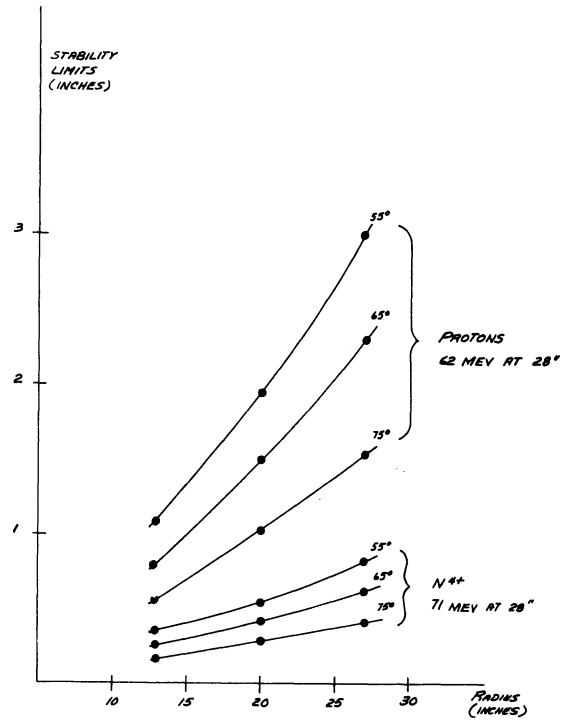

Fig. 6 Isochronous field radial stability limits.

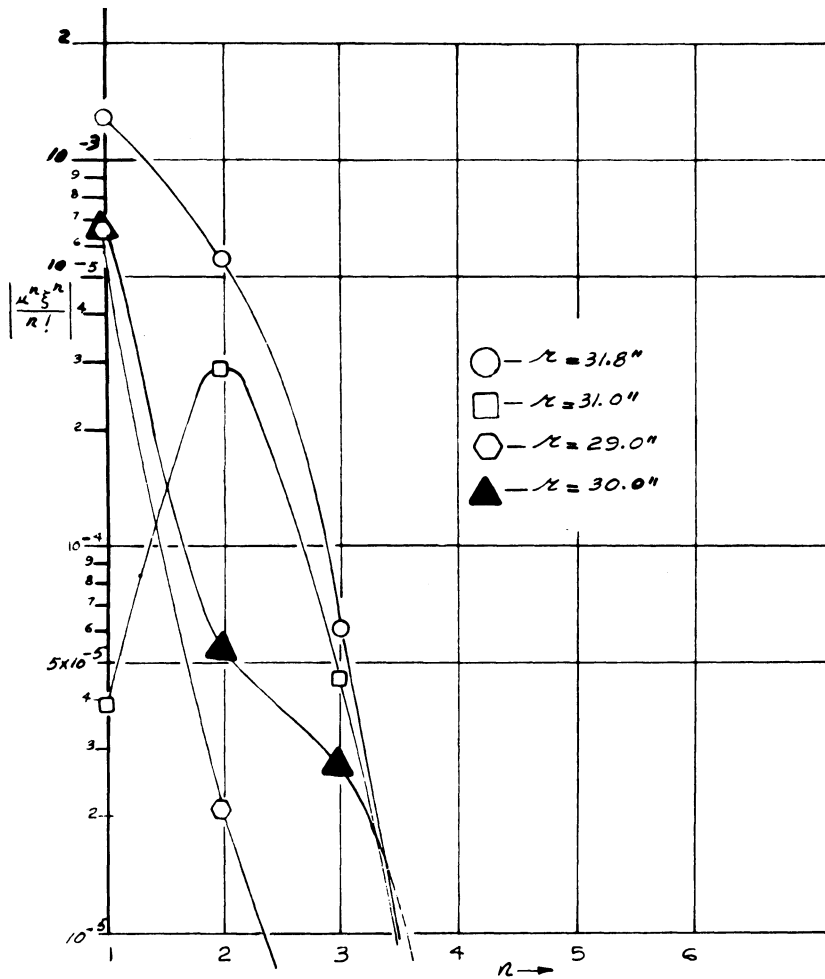

Fig. 7 Approximate strengths of non-linear driving terms from the radial derivatives, radial oscillation amplitude = $\frac{1}{8}$, $\xi = \frac{1}{240}$, $\mu^n = \frac{r^n}{B} \frac{dB}{dr^n}$.

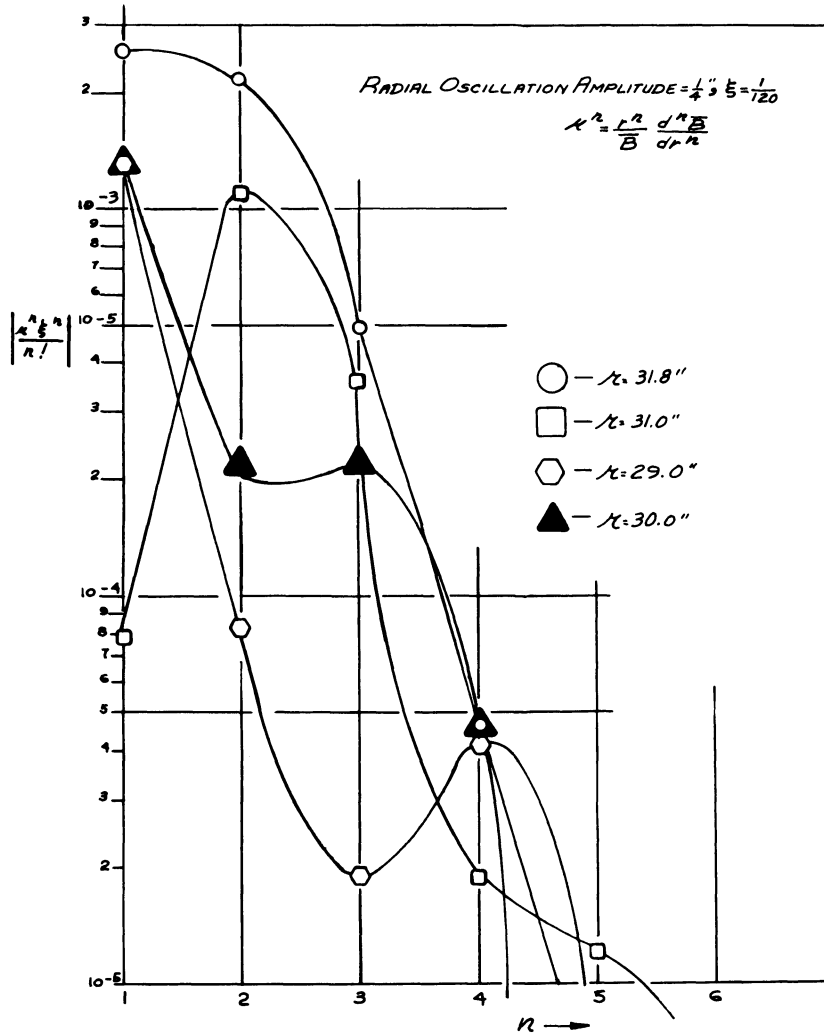

Fig. 8 Approximate strengths of non-linear driving terms from the radial derivatives.

for a spiral angle of 55° , 70 kV was assumed on a 180° dee. Particles started in phase with the RF at 29", gained about 30° of phase, and were about 45° behind in phase at 32". The grid used corresponds to 0.1" in radial amplitude, with inner points at $1/16$ ". In all cases the initial axial amplitude was 0.25 in. Approximately the same phase conditions resulted for the radial phase plots at spiral angles of 70° and 75° , shown in Fig. 10. Initial conditions were identical to those of the 55° spiral case.

For the 12-point input grid used above for the 55° spiral, the z amplitude at extraction radius increased as much as $5/8$ " beyond the dee aperture in only one case. In all other cases the z amplitude at 32" was the same as or less than the initial $1/4$ " amplitude. For 70° spiral the final z amplitude was 0.36" and 0.40" and beyond $5/8$ " in only one case. All other cases of the 0.1" input grid had decreased z amplitudes at extraction. For the 75° spiral 3 cases of 0.1" initial amplitude exceeded $5/8$ " at approximately 85 turns and 5 cases survived without axial amplitude increase to extraction radius.

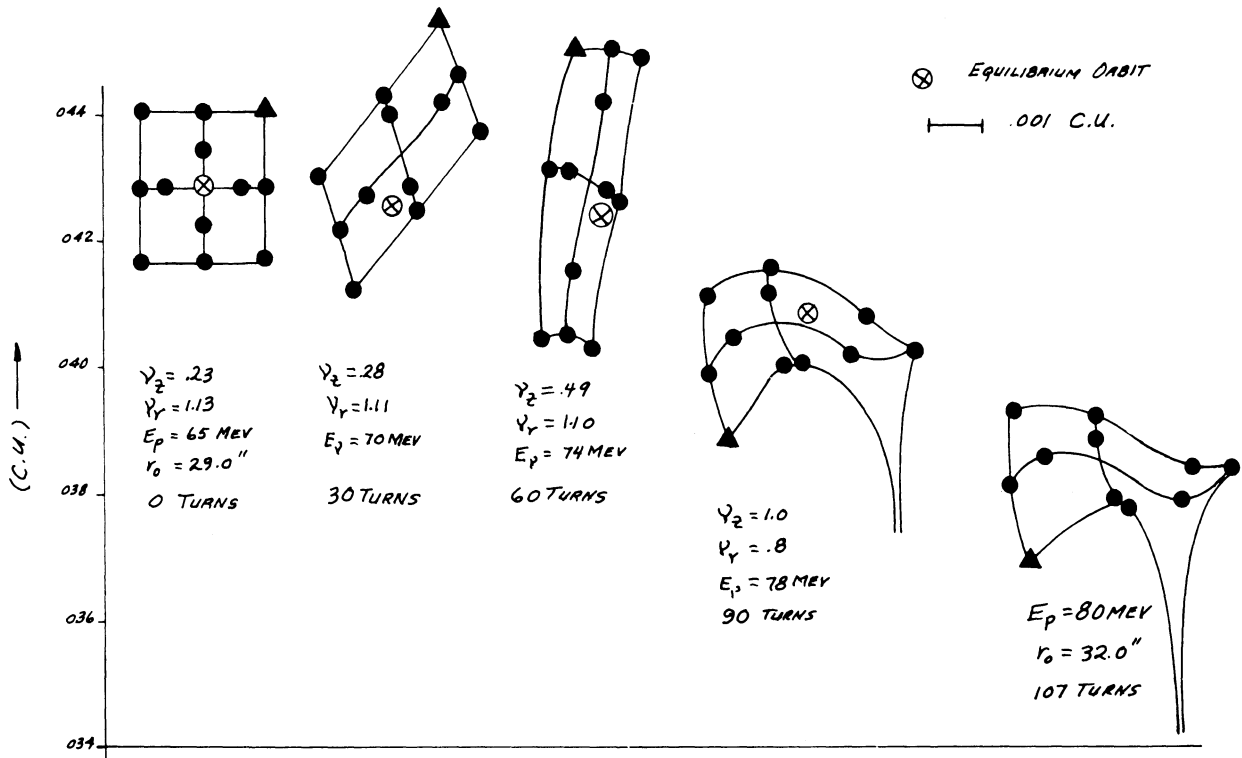

Fig. 9 Radial phase-plane diagrams for accelerated protons, for 55° spiral.

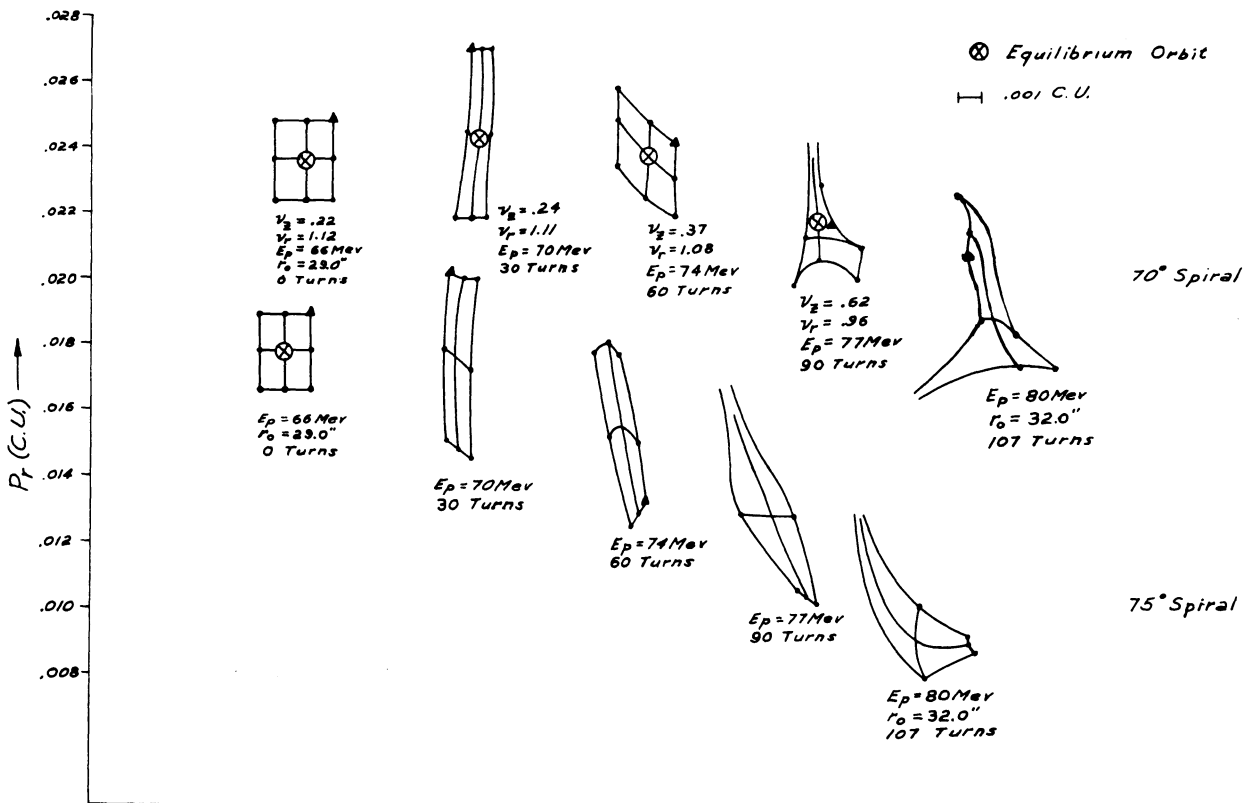

Fig. 10 Radial phase-plane diagrams for accelerated protons, for 70° and 75° spiral.

Acknowledgements

We are very grateful to UCLRL, Berkeley, for use of the 1/5 scale model of the 88" magnet and to Mr. J. Dorst for his assistance and advice. We would like to thank J.C. Baker and R.D. Pillsbury for calculating the linear program on the IBM 1620 computer. The helpfulness of Mr. H. Owens of UCLRL, Berkeley, in running the CYBOUT program is gratefully acknowledged.

References

- 1) M.M. Gordon and T.A. Welton, Nuc. Inst. and Meth. 6, 221 (1960).
- 2) L. Smith and A.A. Garren, UCRL-8598 (Jan. 12, 1959).
- 3) H.L. Hagedoorn and N.F. Verster, Nuc. Inst. and Meth. 18-19, 201 (1962).

DISCUSSION

BLOSSER : The sensitivity of the radial phase space to a bump varies by about a factor of 2 depending on whether the bump is orientated to give a one-cornered or a two-cornered opening. What was the orientation of the bump for the figures you were quoting?

JUNGERMAN : The numbers we quoted here are the conservative ones, the worst phases for radial stability.

LAPOSTOLLE : Could you say a few words about coupling between axial and vertical oscillations.

JUNGERMAN : I did not show the z-motion, but in those cases where the points were lost the axial motion was such that the particles hit the dee. However, in the other cases the z-motion was well confined; one could see hardly any growth. It looks as if one could get a substantial part of the beam through this particular field, which is still not optimized.