

AUTOMATIC SCANNING AND MEASUREMENT OF BUBBLE CHAMBER
FILM ON POLLY II*

W.W.M. Allison[†], F. Beck, G. Charlton, D. Hodges, J.G. Loken[†],
B. Musgrave, H.B. Phillips, R. Royston^{*} and R.A. Sunde

Argonne National Laboratory
Argonne, Illinois 60439, USA

ABSTRACT

An exposure of 600,000 hydrogen bubble chamber pictures of 2.3 GeV/c $\bar{p}p$ interactions in the 30-inch Argonne-MURA chamber is being scanned and measured for 2, 4, 6 and 8 prong interactions by POLLY II, a computer-controlled CRT device. The performance of the automatic scanning and measuring is assessed on the basis of the first 160,000 events processed. The control program searches for beam tracks and finds interactions without prescanning. It digitises the tracks, measures bubble density and outputs master point information ready for direct input to the geometrical reconstruction program. The operator is an integral part of the system

*Work supported by the U.S. Atomic Energy Commission.

[†]Address from June 1, 1970: Nuclear Physics Laboratory, Keble Road, Oxford, England.

[†]Present address: Nuclear Physics Laboratory, Keble Road, Oxford, England.

^{*}Present address: Scientific Control Systems Ltd., London, England.

and is available to give assistance when required. Film is processed at 70-100 events per hour.

1. INTRODUCTION

POLLY II is a precision CRT flying spot digitiser used for the automatic scanning and measurement of bubble chamber film at the Argonne National Laboratory. The device, of which POLLY I¹⁾ was a prototype, is on line to a 48 K Sigma 7 computer. Extensive innovations in the FORTRAN control program²⁾ have enabled us to measure film which has not been prescanned at all -- thus in a single pass of the film, under computer control, the stages of scanning, measurement, and track density determination are completed. Full-scale production on a 2.3 GeV/c $\bar{p}p$ experiment started in April 1969. By January 1, 1970 a total of 160,000 events had been scanned and measured in 2135 hours (an average of 75 events/hour). In this paper we discuss the performance of the POLLY system on the basis of this experiment. It should be pointed out, however, that POLLY II measured four other experiments during the year (1.5 GeV/c π^+d , 5.5 GeV/c K^-d , 5.5 GeV/c K^-p , 5.5 GeV/c $\bar{p}d$) for which the film was prescanned (vertex position on the first view only). This amounted to a further 80,000 events. During the year continued program development has led to further improvements in both the quality and the rates of scanning and of measurement.

2. THE SYSTEM

The POLLY system is concerned with the interfacing of three elements: the film, the operator and the computer. Information has to be extracted from the film by the computer -- the operator is a

backup system. The interface structure is shown below:

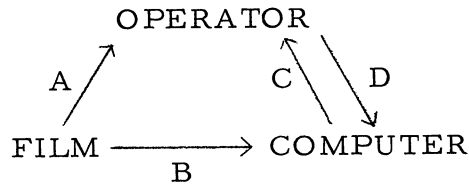

We now discuss the nature of the four interfaces A - D.

Interface A is an optical projection of the film allowing the operator to look directly at the whole picture.

Interface B is a 9" Ferranti precision cathode ray tube (type 9B/71Q0). A spot on the tube is imaged with 2:1 demagnification onto 70 mm film and swept through a raster scan of a small area at the required angle by magnetic deflection coils around the neck of the tube. The photomultiplier output is compared with a discriminator level to yield digital data about the position of bubble images on the film. This operation and the resulting digital data is called a "slice scan"^{1, 2}.

Interface C is an IDI display CRT (type 21EM10P7) with character and vector generators. It is used to show the operator what the program is doing, what information it has obtained already, what its problems are and to display areas of unfiltered digitisings relative to which the operator may make precision measurements. An example of this is shown in Fig. 1. The area displayed is 3.8 mm in diameter on film. The picture is built up by individual slice scans to form a real time picture. The operator can "drive" the picture under the cross-mark to make a precision measurement of a vertex point or whatever may be requested by the program.

Interface D consists of an array of 32 buttons forming a word which can be read by the program, a track ball driven pointer which

is associated with a reticle on the optical display, and an orientation knob. The track ball feeds an X-Y register which can be loaded or read by the program. The reticle is used to indicate features to the program, but not to make precision measurements. The program can selectively illuminate buttons so that the operator is presented with a meaningful selection of possible courses of action.

The logical structure is summarized in Fig. 2.

During operation the system is in one of four states. They are distinguished by whether the computer or operator is in control and by whether the optical display (interface A) or the precision CRT (interface B) has access to the film.

<u>State</u>	<u>Control</u>	<u>Computer</u>	<u>Operator</u>	<u>Interfaces</u>
I	Operator	Idle	Active	A, C, D
II	Operator	Looping	Active	B, C, D
III	Computer	Active	Watching	B, C
IV	Film transport	-	-	-

Fig. 3 shows a photograph of the hardware with diagrams of the light paths for State I ("Display Mode" - Interface A) and States II/III ("Measure Mode" - Interface B).

Fig. 4 is a view of the operator's console. The screen on the left is the optical projection; the one on the right the display CRT. The track ball is in the center and the array of 32 special purpose buttons is on the right.

Most of the time the operator is powerless and the system runs in State III or State IV. Only when the control program diagnoses a possible problem does the system drop down into States I and II (~ 25%

of views measured, depending very much on film quality). Once, however, the operator is given control, he can guide the program, slice scan by slice scan if necessary, to overcome problems which are beyond the current program's logic.

3. PROGRAM STRATEGY

Most bubble chamber events are easy to measure and only a small fraction of tracks causes problems. This leads to the use of fast simple logic until trouble is encountered. The operator is viewed as a very sophisticated, relatively cheap and very slow "peripheral" whose role is to fix up those situations which do not yield to this approach. In order to keep him fully informed and to enable him to react as quickly as possible, a great deal of thought and effort has gone into his interface with the program. This man-computer interface has a significant side-effect; it allows the programmer elaborate real-time debug displays which play an important part in the development of the program. Of equal importance is the feedback from full-scale production which has been proceeding in parallel with further program development. This philosophy has allowed us to "bootstrap" our way into the use of more sophisticated methods, so that now the operator is idle for significant periods of time (depending on the film quality).

An important advantage of the CRT is the use of the random accessibility of data on film. Thus the total data storage in core is less than 3,000 words excluding the display buffer. In this way we avoid extensive bookkeeping operations and save computer storage.

To avoid reading in large quantities of experiment-dependent data, many constants in the program are "learned". These include the shifts and magnifications of the chamber image on the film, the

depth of the beam plane in the chamber, the density of minimum ionising tracks, the angle of beam tracks entering the chamber, etc.

A single I/O instruction to the POLLY hardware produces digitisings from a set of scan lines forming a "slice scan". Each scan line is represented by one word in core which has a capacity for data from one track crossing. A slice scan, therefore, appears in core as a vector with one element per line. The software uses the slice scan in two different ways. These may be called "searching" and "following" and are illustrated in Fig. 5(a) and (b) respectively. In searching the program is trying to make contact with a new track as quickly as possible. It is fast because the hardware only need be initialised occasionally and the software need only count lines and look for the presence of groups of digitisings without detailed analysis. Once a track has been found, the "following" method is used. This is slower but more precise because the software uses the edge and width count information for each digitising.

The whole operation may be separated into three phases -- scanning, fiducial measuring and event measuring. The scanning phase produces one or more approximate production vertex positions. For prescanned film the scanning phase is omitted and the approximate vertex position and topology are read from a tape.

Automatic scanning is done on the first view only. The program does a track search along the leading edge of the fiducial volume. It then follows each beam track candidate, first upstream out of the fiducial volume and then downstream until it loses it or reaches the far end of the chamber. The program saves time by leaping down the track digitising only 25 to 50% of the track, taking about 150 milliseconds

to reach the far end. Beam tracks closer than 250 microns on film and off-momentum tracks are ignored -- care being taken to cover the possibility of a forward high momentum secondary from an interaction near the edge of the fiducial volume. Next the program searches for secondaries issuing from the end of each beam track that terminated within or near the fiducial volume. It follows each of these for a short way, ignoring those that pass right through the expected vertex region, and looks for those that intersect the given beam track within 500 microns of one another or at the end of the measured beam. When this condition is satisfied, the rough vertex position is stored away. There are also problem cases which include suspected forward secondaries mentioned above, zero prongs, very small angle elastic scatters and other cases where the required secondary tracks are not found. For these the operator is asked to point out the vertex using the track ball, or to press the "abandon" button, if there is no event or it is to be ignored (zero prongs and small angle elastic scatters in our case). About 15-20% of the events are fixed up in this way -- it takes the operator 1 - 2 seconds to make the decision in most cases. The total path length of good beam tracks within the fiducial volume is calculated. A running total is available for cross section purposes.

A map of ten fiducials with their arm lengths and angles is fed into the program as data. A searching slice scan is used as shown in Fig. 5(a) to find the fiducial and then each of the four arms is measured with a single slice scan as in Fig. 5(b). As many as 8 and at least 5 fiducials are measured on each view. The film is accurately positioned by measuring two fiducials employing a more extensive search pattern.

The track measuring sequence consists of the following operations:

- i) Search for tracks along the sides of an octagon centered on the approximate vertex position (see Fig. 5a).
- ii) Follow each track found outwards and then back towards the vertex (provided the track has not already been measured and that it passes close enough to the vertex region).
- iii) Identify tracks passing right through the vertex region and those measured twice by mistake.
- iv) Attempt to calculate a vertex position by considering the intersections of all pairs of tracks. If successful, eliminate tracks that do not belong.
- v) Decide whether to return to (i) to look for more tracks.

The complete sequence is looped through for up to seven different track searching octagons. Their radii are 6000, 3000, 2000, 1000, 300, 9000, and 15000 microns. If after any octagon the vertex has been found and all the tracks of the topology have been measured, the sequence is terminated. If the topology is not known, all octagons are completed. Thirty to forty percent of the views in the \bar{p} experiment only required the first octagon.

The next stage is a meticulous checkout of the tracks as follows:

- Beam track identification;
- Charge balance;
- Agreement with topology (as found on view 1 or as given);
- Existence of well-defined vertex point;
- Stopping points measured as such.

Other problems requiring operator attention are also found:

- Tracks which, though consistent with passing through the vertex, do not extrapolate to within 100 microns of it;

Tracks with fewer than 8 points;
Tracks which end in "confused" regions;
Tracks which might be stopping (on newly scanned events).

If there are no such problems, the program flashes the completed measurement on the screen for the operator's benefit and continues to the next view.

If there are problems, the program displays its measured tracks and its list of problems to the operator and switches to State I (display mode) to allow the operator to study the situation. If the trouble is with the vertex definition, the program goes into State II inviting the operator to give a precision vertex measurement. As soon as the operator has pressed a button, the program performs the indicated tasks and starts the checkout process over again. Every time the operator adds or deletes tracks the vertex position is recalculated. The program will not continue until all the "fatal" errors are removed.

4. THROUGHPUT

Fig. 6 shows the weekly average measurement rates for various experiments over the period April-December 1969. The first four experiments were prescanned for the following topologies (the letter s refers to stubs).

5.5 GeV/c K^-d	3, 3(s), 4 prongs as well as 1, 1(s), 3, 3(s) prongs + V^0
1.5 GeV/c π^+d	3(s), 4 prongs
5.5 GeV/c $\bar{p}d$	1(s), 2 prongs
5.5 GeV/c K^-p	2 prongs

The 2.3 GeV/c $\bar{p}p$ experiment was automatically scanned for 2, 4, 6 and 8 prongs, elastic scatters with recoils less than 1.5 cm being excluded.

The throughput is particularly sensitive to low track densities (as in the case of the π^+d experiment), poor contrast fiducials and features presently requiring operator assistance (such as vee vertices and stubs). It is relatively insensitive to the number of beam tracks provided these are well spaced (10 - 12 per picture), and to whether the film is prescanned or not.

Fig. 7 shows a breakdown of where the time goes when POLLY is scanning and measuring at peak rate. These numbers vary widely for different topologies and film qualities. Under more adverse conditions, the program "tries harder" but also requests operator assistance more often during the measuring phase -- the operator time might rise as high as 30%. The CPU is busy about 75% of the time.

During actual track following the CPU is busy 95% of the time and the POLLY hardware is being used 55-60% of the time. Tracks are followed at 60 milliseconds per centimetre on film.

5. ACCURACY

The calibration program, an overlay of the standard POLLY measuring program, measures 90 to 100 points on a standard grid. From these it evaluates misadjustments of the ramp speeds and delay circuits and checks the stability of the deflection and hysteresis effects in the coils. Finally, using average values for the grid point coordinates measured many times over in a pseudo-random order, it calculates a correction polynomial. The following residuals are typical (in units of 1 micron on film \equiv 2 microns on the tube face):

	<u>RMS</u>
A grid point measured many times in the same way.	0.5 - 1.0 μ
A grid point measured many times but with different widths and orientations of slice scans.	0.7 - 1.5 μ
A grid point measured many times but with all the other points being measured in random order inbetween.	1.5 - 2.0 μ
100 grid points fitted to best rectangular grid.	10 - 20 μ
100 grid points fitted to a third order polynomial.	1.5 - 2.0 μ
100 grid points fitted to a fifth order polynomial.	1.0 - 1.5 μ
100 grid points compared with the previous day's fifth order polynomial.	1.5 - 2.5 μ

We have observed drift effects associated with tube warmup which disappear after the tube has been on for a few minutes. We conclude that the deflection is stable and reproducible to better than 2.5 microns over the field of view (diameter 64,000 microns).

Fig. 8 shows the helix fit residuals for track reconstruction as given by the geometry program TVGP. The distribution peaks near 5 microns and does not have a long tail. Events fitting the final state $\bar{p}p \rightarrow \pi^+ \pi^- \pi^+ \pi^- \pi^0$ at 2.3 GeV/c with a single constraint show a strong signal due to ω^0 in the $(\pi^+ \pi^- \pi^0)$ invariant mass histogram. Fig. 9 shows this histogram in 2 MeV bins. The experimental full width of the signal is 22 MeV to be compared with the natural width of 13 MeV. Much better resolution is of course obtained for variables not involving a missing neutral or annihilation.

6. SCANNING AND MEASURING EFFICIENCIES

We have evaluated the efficiency of automatic scanning in two ways. In the first we rescanned several rolls of film by hand. A total of 9% (March 1970) to 15% (November 1969) extra events were found

which POLLY had missed³⁾. The exact definition of the fiducial volume and scanning rules (beam tracks less than 250μ apart excluded) gave rise to borderline cases which have been included to derive an upper limit for the scanning loss. We have found that POLLY fails to find and follow from 4 to 7% of all beam tracks and consequently misses from 4 to 7% of all events in an unbiased way. Discounting this loss, we conclude that the scanning efficiency is better than 90%.

In a second evaluation we compared the total number of events found by POLLY (including 0-prongs and short elastic scatters not normally measured), the total beam track length recorded by POLLY as scanned and the known total cross section for $\bar{p}p$ at 2.3 GeV/c which is $84 \text{ mb}^4)$. In this exposure a Cerenkov counter in the separated \bar{p} beam vetoed the camera flash whenever any beam contamination was detected. We therefore assume that the path length is all \bar{p} . In a sample of 8007 metres of track POLLY found 2349 events indicating an observed cross section of $81 (\pm 2) \text{ mb}$ (March 1970). We applied the same check on a roll of 5.5 GeV/c K^-p film using the same rather large fiducial volume. A total of 272 events were found in 3143 metres of track. This represents $24 (\pm 2) \text{ mb}$ to be compared with the known cross section of $24.3 (\pm 0.8) \text{ mb}^5)$. However these figures are not uniquely related to the scanning efficiency since there is the possibility of bias in the recording of scanned beam track length as well as the loss of events.

The manual rescan showed that 1/2 - 1% of events scanned and measured was measured with the wrong topology, measured twice in error or simply did not exist. In many cases such errors would be the fault of the operator.

From 2 - 3% of events were abandoned during the measurement process. Frequently this was due to off-momentum beams or totally

obscured tracks. We estimate that a third or less of these might have been usefully measured on a conventional machine while they could not be measured on POLLY.

The failure rate in geometry has shown continued improvement:

<u>Run</u>	<u>2 Prong</u>	<u>4 Prong</u>	<u>6 prong</u>	<u>Total</u>	<u>No. of Events</u>
I	11.6%	16.4%	26.9%	14.5%	70639
II	6.0%	12.6%	20.5%	9.6%	66997
part III	4.6%	10.8%	19.9%	8.0%	4740

So far only a sample of the failures have been remeasured on POLLY. Of this sample two-thirds passed geometry the second time.

7. IONISATION

As POLLY follows a track, it records the number of hits (H) and misses (M) and the average track width (\bar{W}). The projected ionisation is given by⁶⁾

$$I_{\text{proj.}} = \frac{k_i}{\bar{W}} \ln \left(\frac{H+M}{M} \right)$$

where k_i is a constant to be determined for each view. There are no problems associated with geometrical factors since the track is always digitised by sweeping the spot at right angles to the track. To reduce systematic effects, ionisation information is ignored at the ends of the track and near the edge of the chamber. During the measurement of a view the program holds the discriminator level constant. If it is changed by the operator, then \bar{W} compensates for the effect of change in the apparent bubble size.

After kinematic fitting to a given hypothesis, the projected ionisation is computed for each track on each view. In comparing

these values with the measurements, the following assumptions are made:

- i) The error on the measured ionisation is taken as 1.2 times the statistical error, as determined from the width of the ionisation stretch function.
- ii) Different views of a given track yield independent ionisation estimates.
- iii) Tracks with ionisations greater than 3.0 are treated specially to avoid problems due to "saturation".

Tracks which are found to have large dips are excluded from ionisation analysis. A total χ^2 is calculated by summing over all track/views and minimised with respect to the three-view normalisation parameters, k_i .

Fig. 10(a) shows the χ^2 probability for some 200 fits of 4, 6 and 8 prong events to four constraint hypotheses. We attribute the peaking to the second assumption made above, which is unsatisfactory when the problem is no longer dominated by systematic errors. Four events had ionisation probabilities below 0.1%.

Fig. 10(b) shows the measured ionisation for beam tracks from a general sample of events. The factors k_i have been calculated by fitting the ionisation of the secondary tracks. The curve is a Gaussian ($\sigma = 0.17$).

Fig. 10(c) is a histogram of measured errors for secondaries with ionisations less than 1.9 -- it is compatible with the width of the Gaussian in Fig. 10(b).

Fig. 11 is a plot of the measured ionisation projected back onto the track and averaged over the 3 views against fitted momentum.

The K tracks are taken from a much larger sample of film than the π and proton tracks.

8. CONCLUSION

This report has discussed the performance of POLLY during 1969. Since then further work has brought new improvements. More than 21000 events were measured in two weeks in March 1970 at over 100 events per hour. The present software is set up to scan N-prongs and measure either N-prongs or N-prongs with a single V^0 . The extension of the program to handle multiple V^0 events with or without prescanning is envisaged as the next stage of development. Problems associated with large chambers, "coat hangers" and Scotchlite illumination have been studied, and tracks have been followed successfully on film from the Argonne 12' chamber, the BNL 80-inch chamber and the CERN 1-metre model.

A new device, POLLY III, is nearing completion of the design stage at ANL (March 1970) and four manufacturers have shown interest in tendering for its production. POLLY III will have four film transports, an indexed mirror and one precision CRT. Standard slice scan analysis will be hardware-wired. We anticipate 15 to 20% improvement in overall speed on line to the same XDS Sigma 7 with similar film.

In summary, by pursuing a philosophy of sophisticated operator interaction and simply programmed logic, we have learned how to implement progressively more sophisticated algorithms to reduce the use of the operator. The close liaison between production and development has been another factor in the development of the present system which can process events completely at more than 100 events per hour so that most frames of the experiment are never seen by the human eye.

ACKNOWLEDGEMENTS

The success of this project would have been impossible without the enthusiastic cooperation of a large number of people. Special thanks are due to Bob Zieman and Gary Thelen on the engineering side and to our team of operators for their fine work; lastly to P. McDonald for her care in typing this as well as earlier POLLY reports.

REFERENCES

- 1) R. Barr, R. Clark, D. Hodges, J. Loken, W. Manner, B. Musgrave, P. Pennock, R. Royston and R. Wehman, POLLY I: An Operator-Assisted Bubble Chamber Film Measuring System, Rev. Sci. Inst. 39, 1566 (1968).
- 2) W.W.M. Allison, F. Beck and J.G. Loken, POLLY II: A complete system incorporating facilities for measuring bubble chamber film without prescanning, Vol. I: General Description and Program Manual, Vol. II: Program Text, ANL/HEP 6916 (1969) (unpublished).
- 3) The sensitivity of the program to small angle kinks was tightened at the end of November 1969. Prior to that events with high momentum secondaries within 2 or 3 degrees of the forward direction and whose vertex was near the edge of the fiducial volume tended to get lost.
- 4) R. Abrams, R.L. Cool, G. Giacomelli, T.F. Kycia, B.A. Leontic, K.K. Li and D.N. Michael, Phys. Rev. Lett. 18, 1209 (1967). We are grateful to these authors for allowing us to use their corrected values.
- 5) W.F. Baker, R.L. Cool, E.W. Jenkins, T.F. Kycia, R.H. Phillips and A.L. Read, Phys. Rev. 129, 2285 (1963).
- 6) R.C. Strand, Bubble Density Measurement with the HPD, BCHP-03-O-G (1963) (unpublished).
See also the discussion of bubble density measurement in Proc. of the Intl. Conf. on Advanced Data Processing for Bubble and Spark Chambers, Argonne National Laboratory, ANL 7515 (1968) and references quoted there.

FIGURE CAPTIONS

- Fig. 1. A display built from real time unfiltered digitisings. The area shown is 3.8 mm in diameter on film. The small crosses represent final track master points for output to TVGP. The display can be "moved" under the central cross by the operator's track ball.
- Fig. 2. Block diagram of the POLLY system.
- Fig. 3. (a) Main elements of POLLY hardware.
(b) Light path for operator view of the film.
(c) Light path when digitising film.
- Fig. 4. View of the operator console.
- Fig. 5. (a) The use of long narrow digitising area for finding tracks or fiducial arms.
(b) The use of short digitising area for precision measurement of tracks or fiducial arms.
- Fig. 6. Measurement rates for various experiments over a nine-month period.
- Fig. 7. Pie diagrams showing how POLLY spends its time.
- Fig. 8. TVGP helix fit residuals from a typical sample of tracks (8-10 points per track).
- Fig. 9. The ω^0 peak from the reaction $\bar{p}p \rightarrow 2\pi^+ 2\pi^- \pi^0$ at 2.3 GeV/c. The curve is a Breit-Wigner of width 22 MeV/c².

- Fig. 10. (a) The ionisation χ^2 probability for 200 4- and 6-prong events with 4 constraint kinematic fits.
- (b) The measured beam track ionisation from a general sample of fits, normalised to the secondary tracks. The curve is a Gaussian ($\sigma = 0.17$).
- (c) The measured ionisation error for tracks with ionisation less than 1.9.

Fig. 11. Plot of fitted momentum against measured track density in space (averaged over views). The curves are the $1/\beta^2$ expectations for K, π and nucleon masses.

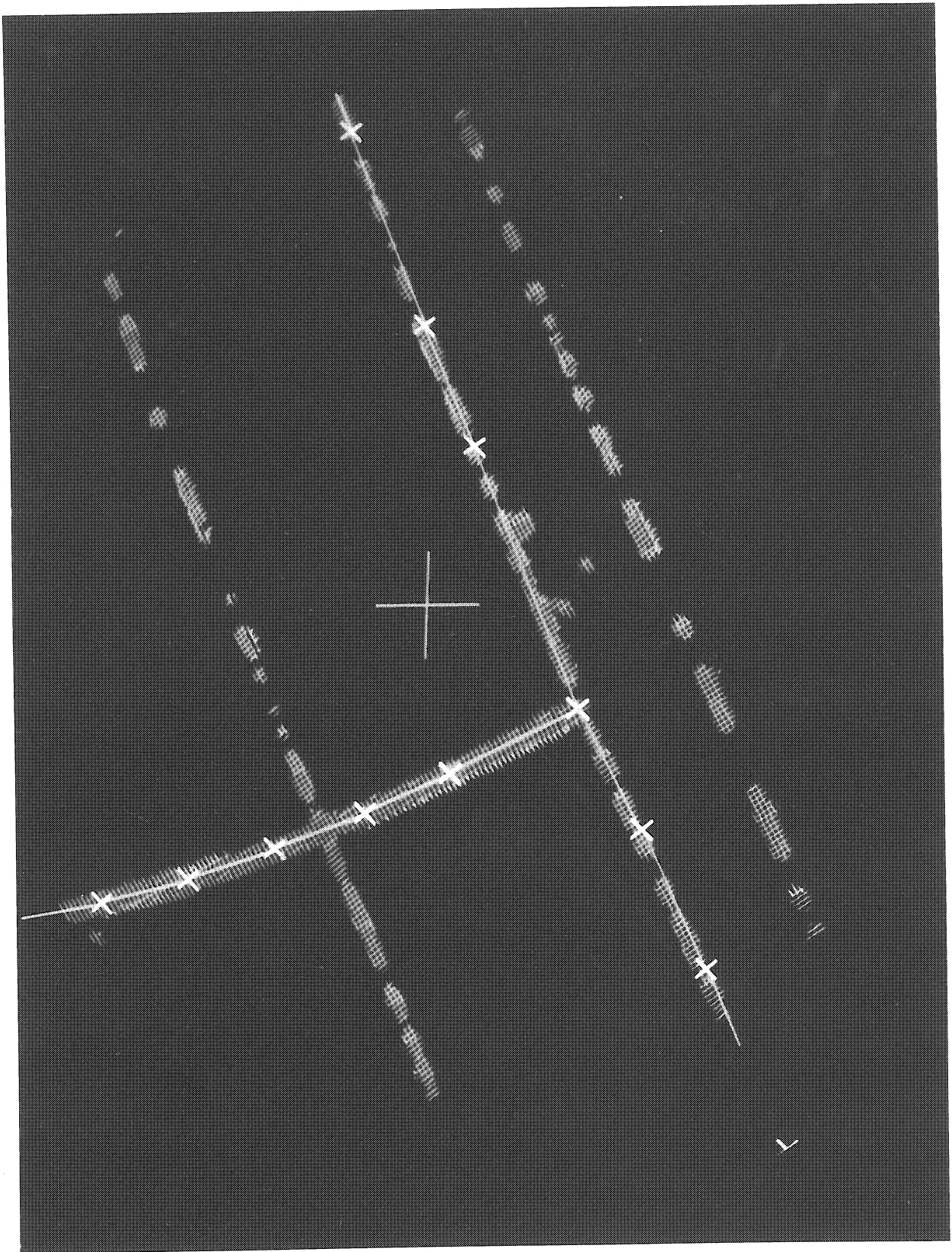

Fig. 1

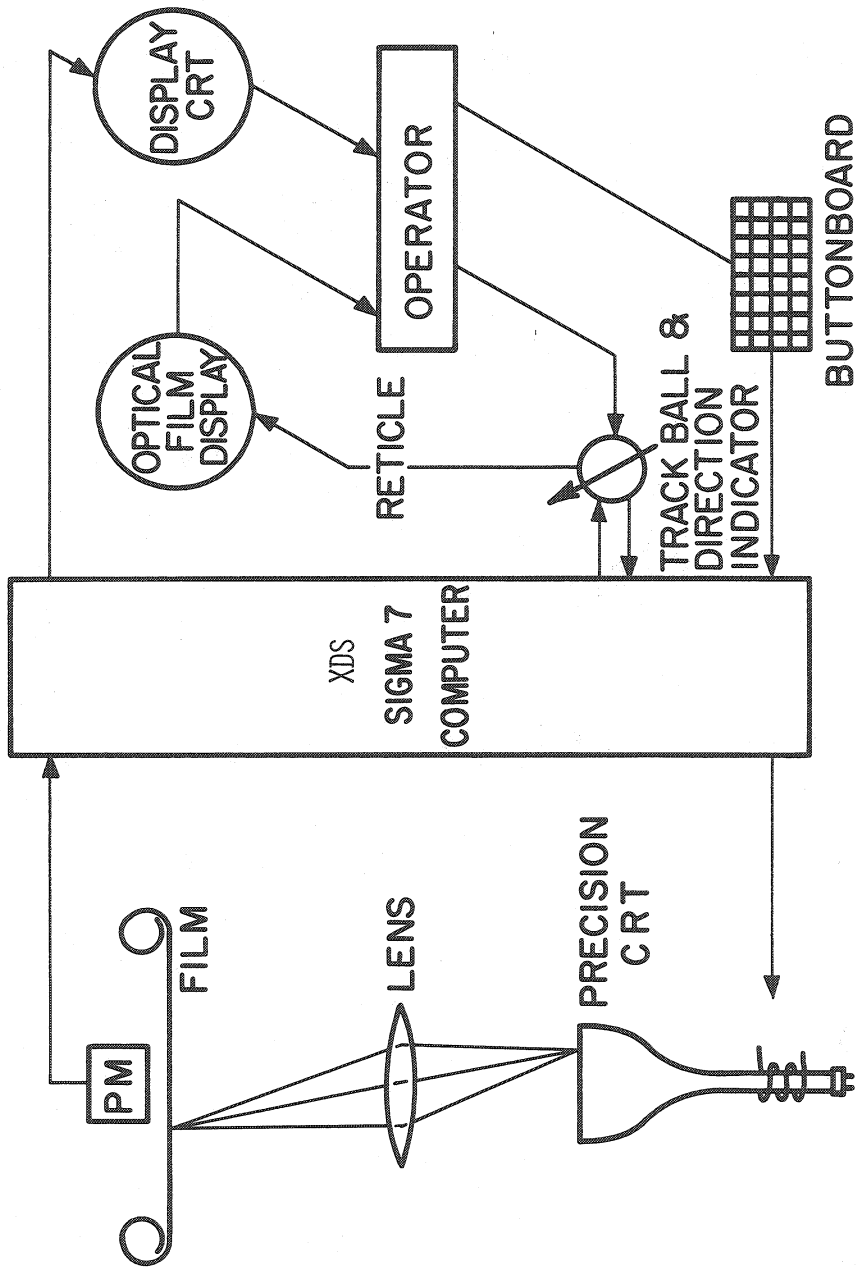

Fig. 2

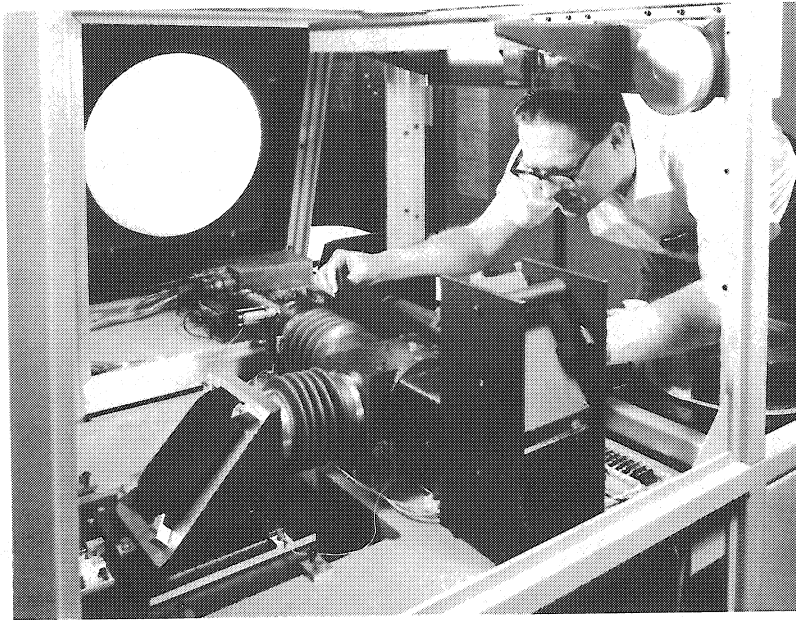

Fig. 3a

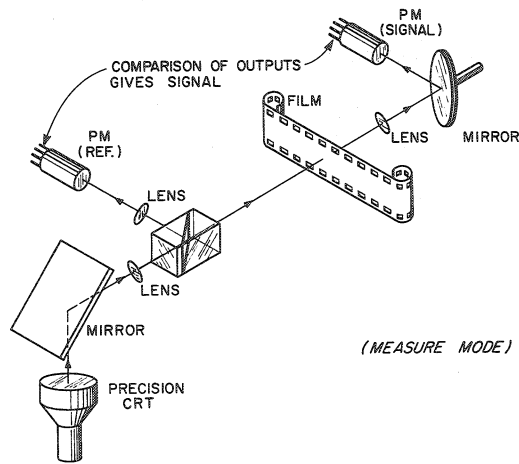

Fig. 3b

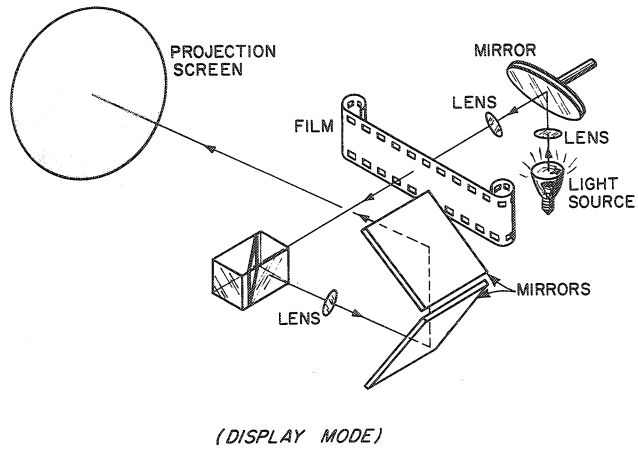

Fig. 3c

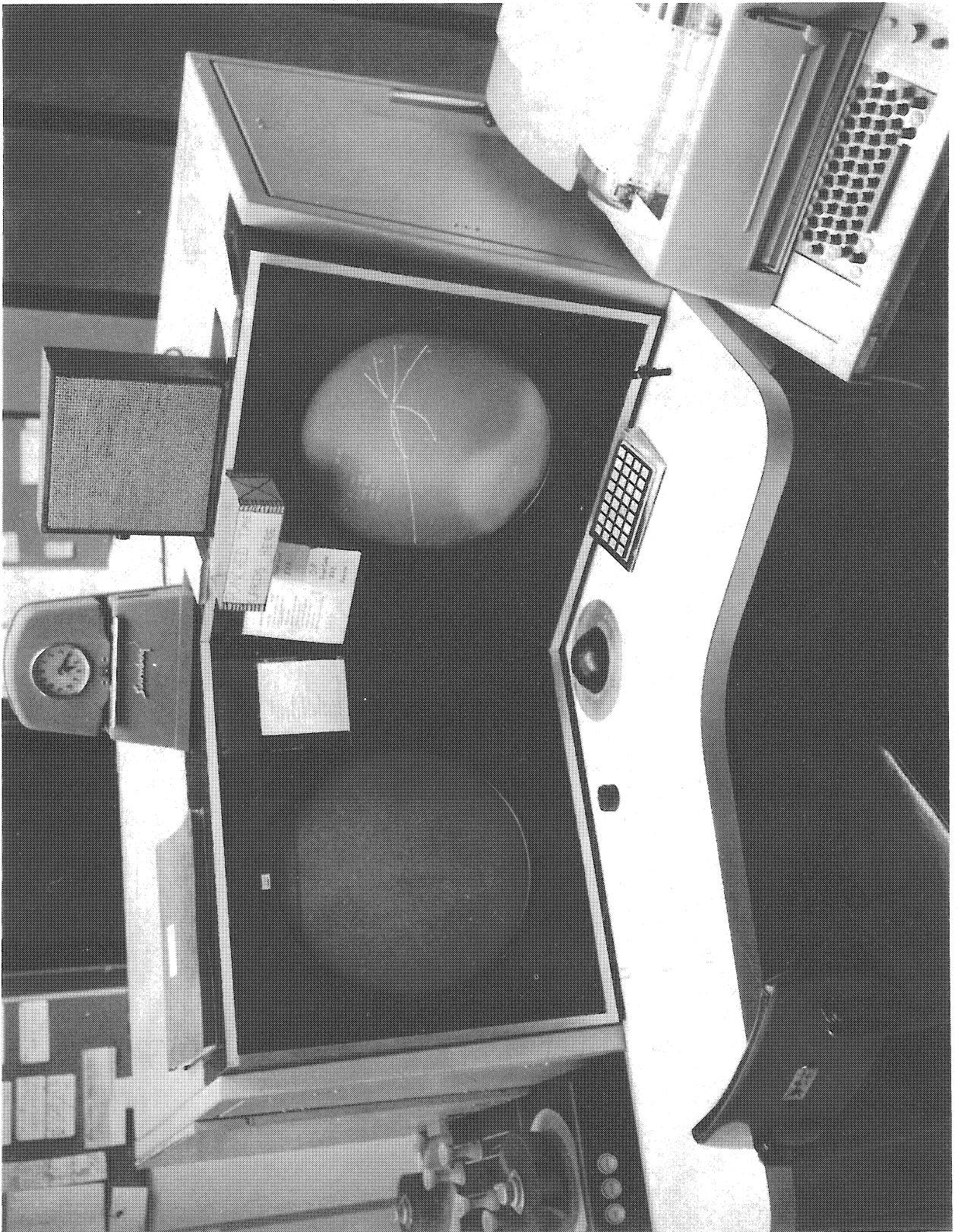
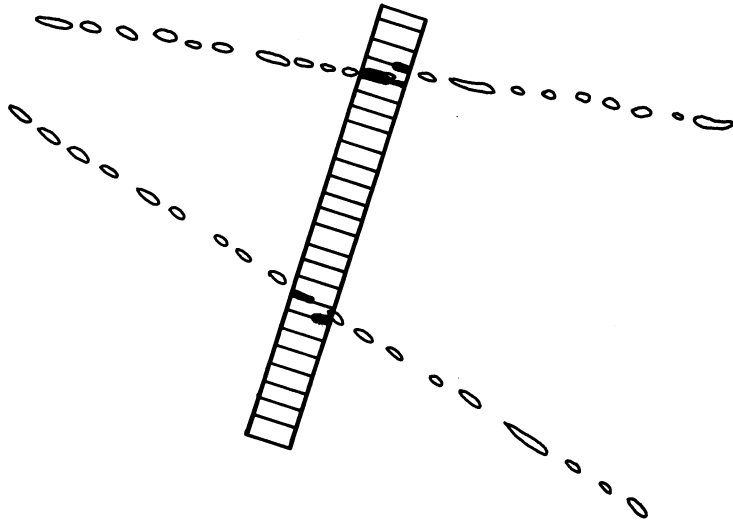

Fig. 4

a) SEARCHING



b) FOLLOWING

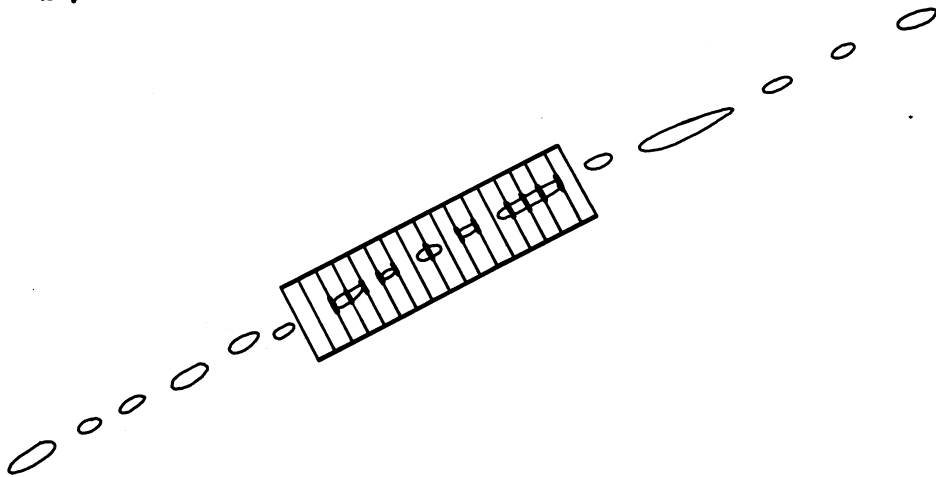

Fig. 5

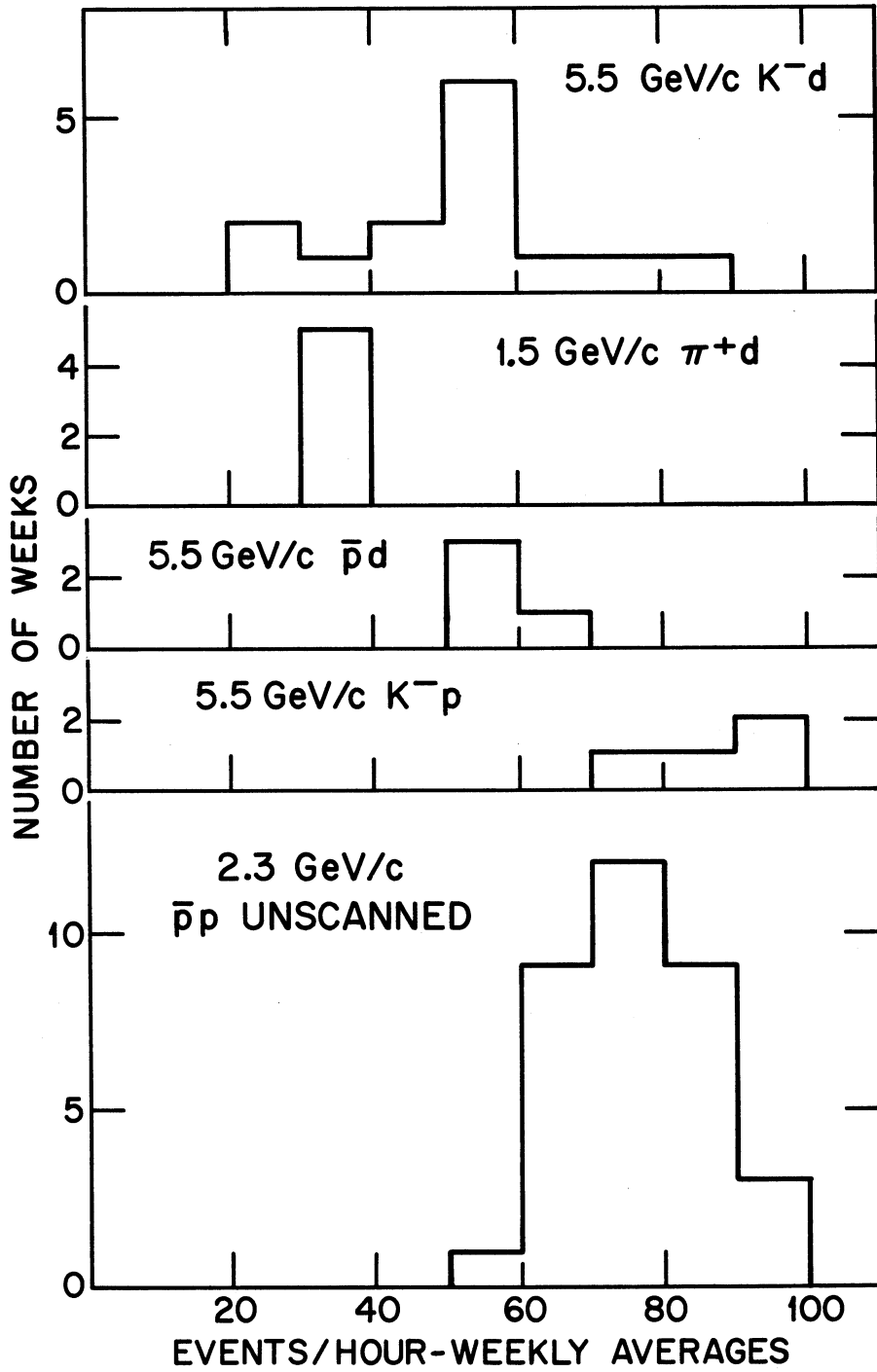

Fig. 6

POLLY TIMING DETAILS AUTOMATIC SCANNING WITH GOOD FILM



Fig. 7

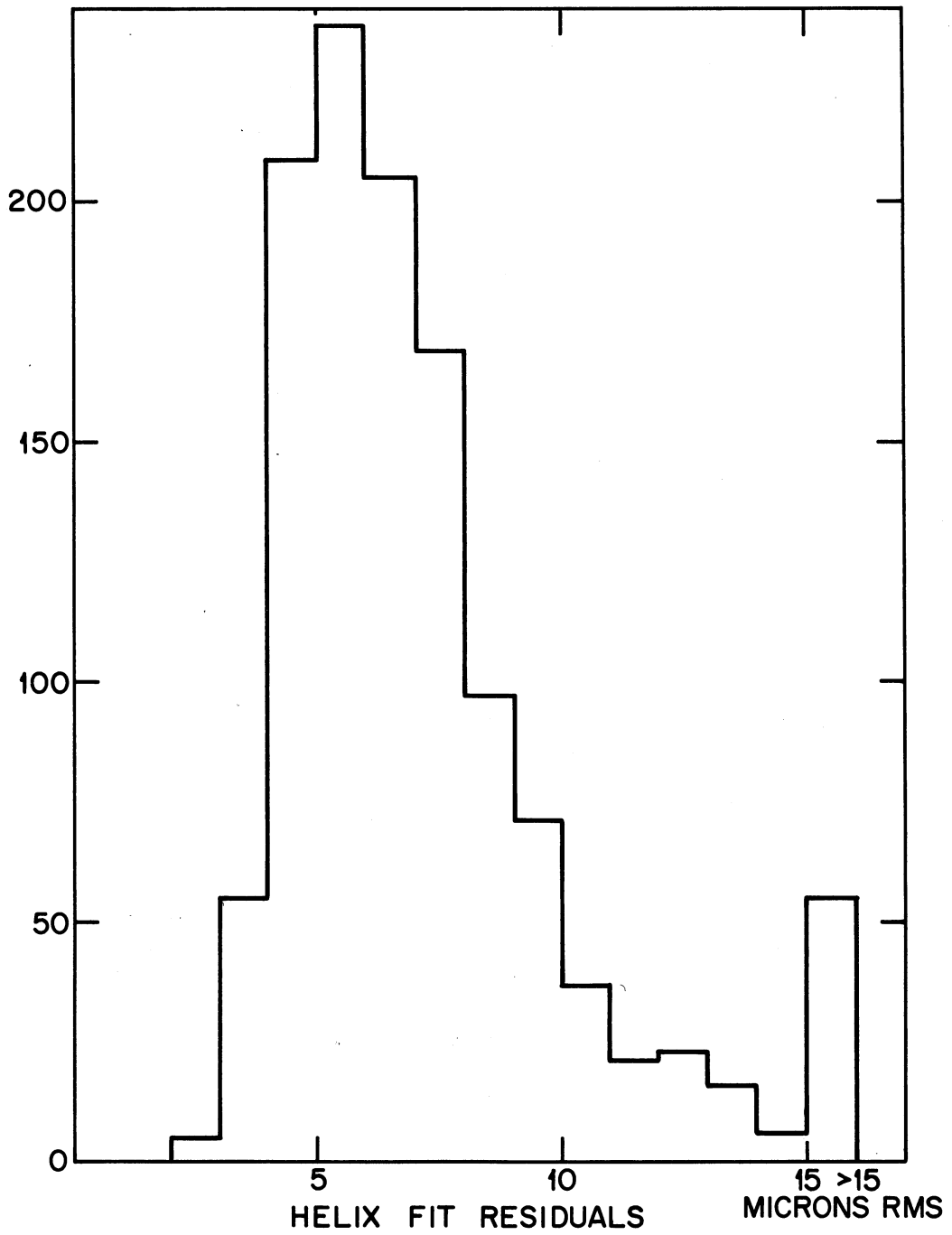

Fig. 8

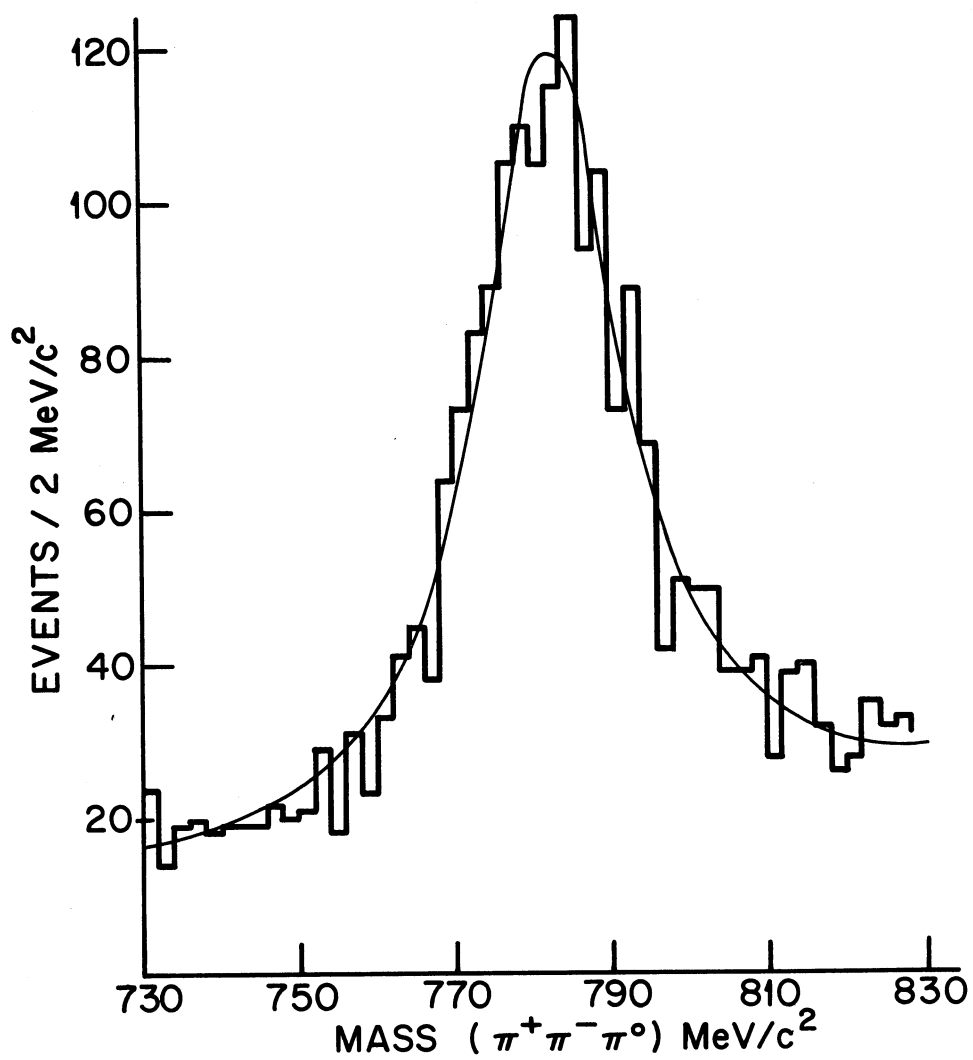

Fig. 9

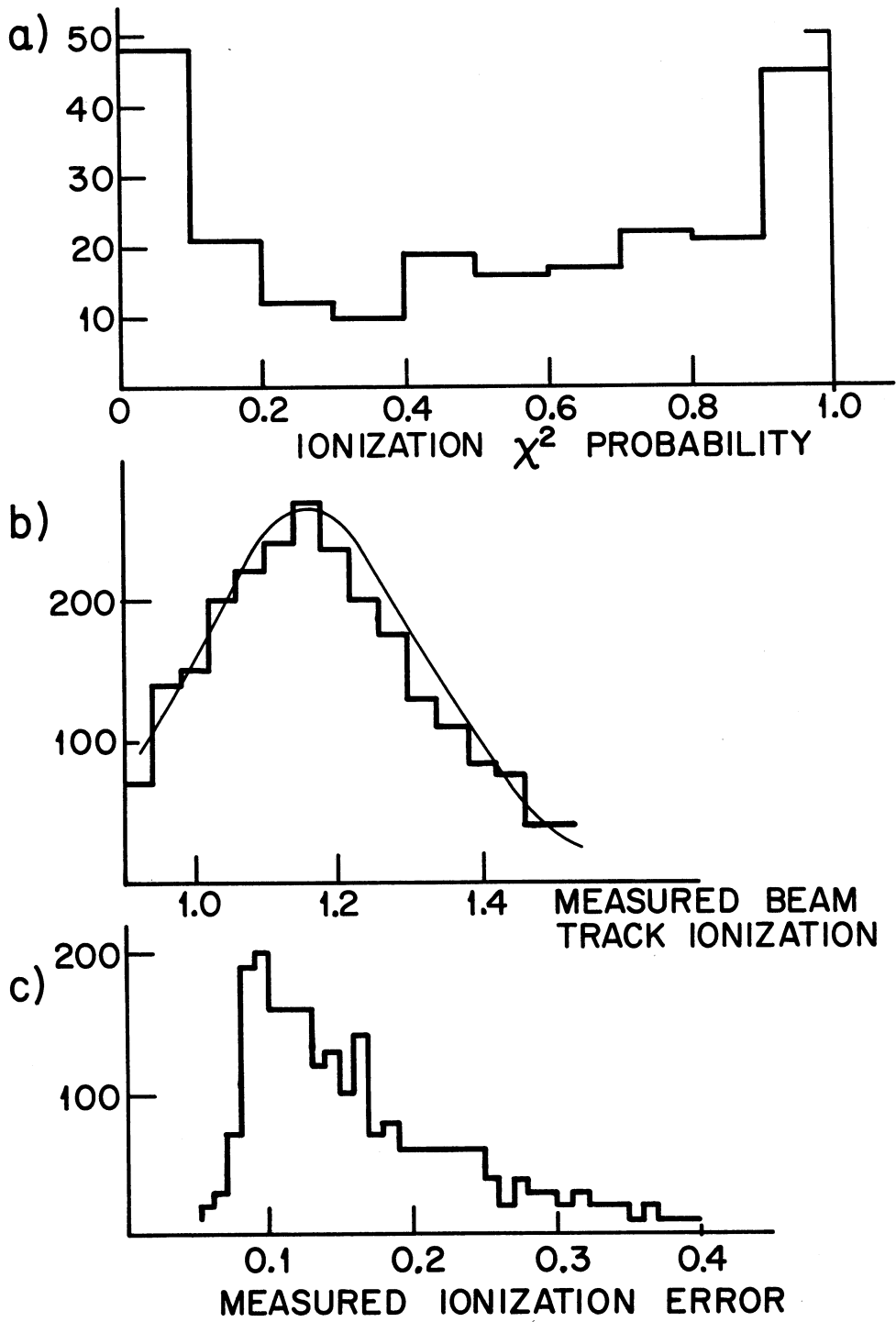

Fig. 10

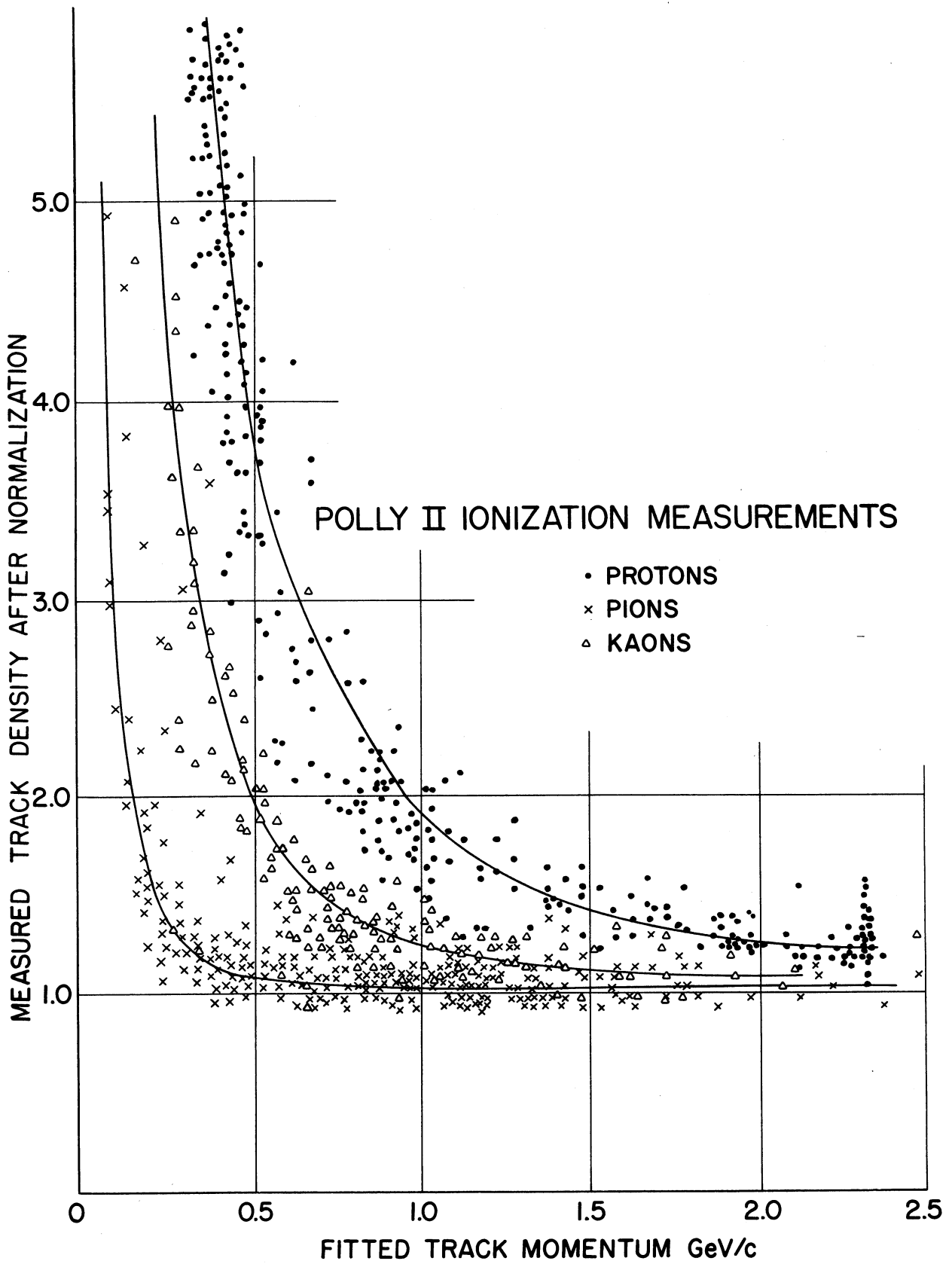

Fig. 11

DISCUSSION

J.P. BERGE (*Oxford*): What is the meaning of the "missed view" comment in the film? Does this mean that no tracks of the event in question have been found?

G. CHARLTON: No. We scan on view 1 and when we go to the next view we know roughly where to look for this vertex, knowing the plane of the beam and so forth. Here the program has decided it's getting too many signals and the film just doesn't look very clean. In fact it has completed all of it's seven octagons and has worked very hard before giving up.

J.P. BERGE (*Oxford*): It seems surprising that as many as 2/3 of the events failing on the first pass can be made to pass by remeasurement on the same machine. Can you make any comment on this?

G. CHARLTON: Well, since the event has already been measured we know the (X,Y) in view 1 for example, this is fed back in and used. Also the operators know that these are remeasurements and so they monitor them very carefully. We put in a debug facility, for example, so that the operator can see the event at the end of each view. They look for kinks which the program didn't detect and that sort of thing. The result is based on small statistics and so may be optimistic but it seems that by being more careful with the remeasurements we can arrive at this success rate.

E. QUERCIGH (*CERN*): What do you think is the maximum number of events per hour which POLLY II can measure on predigitized film?

G. CHARLTON: Well when we are scanning, 32% of the time is spent in scanning and 55% in measuring so that we are still limited by the speed of the machine.

E. QUERCIGH (*CERN*): Have you made any estimate of the cost per event?

G. CHARLTON: No. I did not work that number out.

W.E. SLATER (*UCLA*): With automatic scanning are you able to detect Vs?

G. CHARLTON: The automatic scanning has so far been restricted to n-prong events in a \bar{p} beam and indeed an obvious next direction is to try to scan for V^0 s. A 4-prong with a beam track gives lots of possible combinations to help define the vertex, with V^0 s there is only one, but we intend to try it.

H.H. NAGEL (*Bonn*): If beam tracks are discarded in view 1 due to too high ionization when two beam tracks are on top of one another, is any scan attempted in another view?

G. CHARLTON: No.

H.H. NAGEL (*Bonn*): So events produced by such particles are discarded since it is supposed that this does not introduce any bias?

G. CHARLTON: That's right.

C.J. ROBINSON (*Glasgow*): When you said you measured 75 events per hour did you mean "frames" or "frames on which events were found" per hour?

G. CHARLTON: 75 events per hour is the average over the year for scanning and measuring \bar{p} film on which there is an event for every two frames.

D.H. LORD (*CERN*): With all the new features which will be in POLLY III, do you think that this will be comparable in speed with, say, the Oxford PEPR?

G. CHARLTON: POLLY III will be a machine of speed similar to that of POLLY II. There are a number of improvements, for example the decoding of the slice scan is being done by hardware instead of by the computer but it is basically the same machine.

R. BOCK (*CERN*): Can you give your definition of a rejected event and can you say whether on-line matching and reconstruction would reduce their number to a negligible amount?

G. CHARLTON: A rejected event is one in which the micron error on a track is above a certain tolerance, the values of the tolerances depend on the experimenter. In our \bar{p} experiment, tracks with more than 60 μm error were rejected. Our matching is done off-line and could probably be improved. We have concentrated so far on processing a large number of events and we will now go back to see what can be done to improve our success rate.

R. BAIRSTOW (*RHEL*): Can you say what would be the cost of POLLY III?

G. CHARLTON: Well POLLY II, considered as a 'one-off' machine cost almost \$250,000, including development costs. If POLLY III became available commercially one would hope the cost would be a little less than that.