



The Applicability of Ultrasonic Oxygen Deficiency Hazard Detectors in the LHC Accelerator Tunnel

K. Brodzinski¹, M. Chorowski², W. Gizicki², W. Ostropolski², G. Riddone¹

Abstract

The Large Hadron Collider (LHC), will contain about 96 tonnes of high-density helium, mostly located in the underground components of the LHC machine. Some of potential LHC cryogenic system failures might be followed by helium discharge to the tunnel and potential decrease of the oxygen concentration below the safety level of 18% cannot be excluded. A novel concept for oxygen deficiency detection can be based on measurements of sound velocity in the atmosphere. The paper presents the test results of ultrasonic ODH detection prototype system in radiation environment similar to that predicted for the LHC.

¹ CERN, Accelerator Technology Department, Geneva, Switzerland

² Wroclaw University of Technology, Wroclaw, Poland

Presented at the 20th International Cryogenic Engineering Conference (ICEC20)
11-14 May 2004, Beijing, China

The applicability of ultrasonic Oxygen Deficiency Hazard detectors in the LHC accelerator tunnel

Brodzinski K.*, Chorowski M., Gizicki W., Ostropolski W., Riddone G.*

Wroclaw University of Technology, Wybrzeze Wyspianskiego 27, 50- 370 Wroclaw, Poland

* Accelerator Technology Department, CERN, 1211 Geneva 23, Switzerland

The Large Hadron Collider (LHC), will contain about 96 tonnes of high-density helium, mostly located in the underground components of the LHC machine. Some of potential LHC cryogenic system failures might be followed by helium discharge to the tunnel and potential decrease of the oxygen concentration below the safety level of 18 % cannot be excluded [1]. A novel concept for oxygen deficiency detection can be based on measurements of sound velocity in the atmosphere. The paper presents the test results of ultrasonic ODH detection prototype system in radiation environment similar to that predicted for the LHC.

INTRODUCTION

The cryogenic system of the LHC machine is characterized by specific design features, which make it inherently safe. Nevertheless, as it was specified in the preliminary risk analysis [1], some of potential LHC cryogenic system failures might be followed by helium discharge to the tunnel and potential decrease of the oxygen concentration below safety level of 18 % in underground tunnel and caverns cannot be excluded. The LHC oxygen deficiency detection system will comprise of about 200 ODH detectors installed throughout the LHC machine. Standard commercially available ODH detectors usually operate on the galvanic cell principle and they measure directly the oxygen concentration.

A novel concept for oxygen deficiency detection is based on the dependence of sound velocity on the atmosphere composition [2]. The oxygen concentration is derived on the assumption that the gas added to the air is helium. The sound velocity a in a perfect gas mixture is described by equation (1). Figure 1 presents the dependence of sound velocity on the helium concentration in the helium-air mixture, calculated and measured at temperature equal to 300 K. The sound velocity for helium-air mixture depends strongly on the mixture composition and it is about three times higher for pure helium than for the air alone.

$$a = \sqrt{\kappa \bar{R} T} = \sqrt{\left(\frac{1}{\sum \frac{z_i}{\kappa_i - 1}} + 1 \right) \cdot \frac{\bar{R} T}{\sum z_i M_i}} \quad (1)$$

where:

- \bar{R} - universal gas constant
- R - gas constant of the mixture
- κ - specific heats ratio,
- T - temperature,
- z_i, M_i, κ_i - molar concentration, weight and specific heats ratio of the i -th component

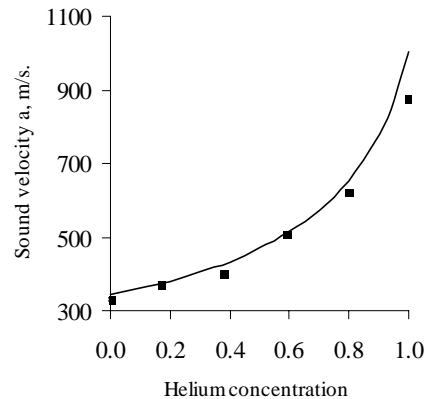

Figure 1. Sound velocity as a function of helium concentration in the air (the line shows eq. (1) calculations and the marks show experimental results)

It results from equation (1) that it is necessary to compensate the temperature influence on the sound velocity. This means that for helium concentration measurement at reasonable accuracy it is necessary to monitor simultaneously the mixture temperature.

EXPERIMENTAL SETUP

In order to qualify the system to be used in the LHC tunnel, the stability of the ultrasonic transducers and electronics has been investigated in the radiation environment, in the conditions similar to those predicted for the LHC. The measurements took place in the TCC2 radiation test zone, situated in the SPS complex at CERN. In the target hall, protons at 400 GeV are dumped on targets to generate secondary particles for the fixed target experiments situated further down stream. The radiation produced is typical of a proton accelerator. A radiation environment in this facility is very similar to that predicted for the arcs of the LHC. For equipment sensitive to particle fluences above $E_{cut} = 1$ MeV, radiation environments of TCC2 test area and LHC are the same. In case of particle fluences with $E_{cut} < 1$ MeV, the TCC2 test area has a higher neutron dose ratio than the LHC radiation environment. TCC2 irradiation facility provides good radiation environment for testing electronics, which could be used in the LHC [3].

Two prototypes of the ultrasonic sound velocity measurements system were designed and built at Wroclaw University of Technology. The systems are aimed at detection of helium relieved to the air in a quantity that may cause Oxygen Deficiency Hazard. The systems have been tested both in active (working continuously) and passive (being triggered once a week for half an hour) mode.

The test set-up is shown schematically in Figure 2. Each system consisted of three parts: sound-velocity measuring unit, bunch of supply and signal cables and control unit. The control unit has triggered the measurements, performed the readout of the results and transmitted the data to the PC. The sound velocity measuring unit, placed in the irradiation zone, comprised two piezoelectric ultrasonic transducers (transmitter and receiver) working at 108.5 kHz resonance frequency, signal processing electronics and Ni160 thermocouple. The electronic system was shielded with 12 layers of one-millimeter sheet of lead. The entire system was closed in the aluminium housing. A mirror placed on an extension arm of 800 mm length reflected the signal emitted by the transmitter to the receiver (Figure 3).

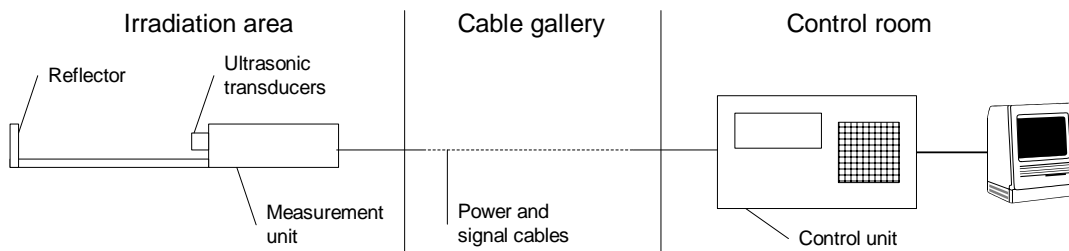

Figure 2. Test set-up schematic view

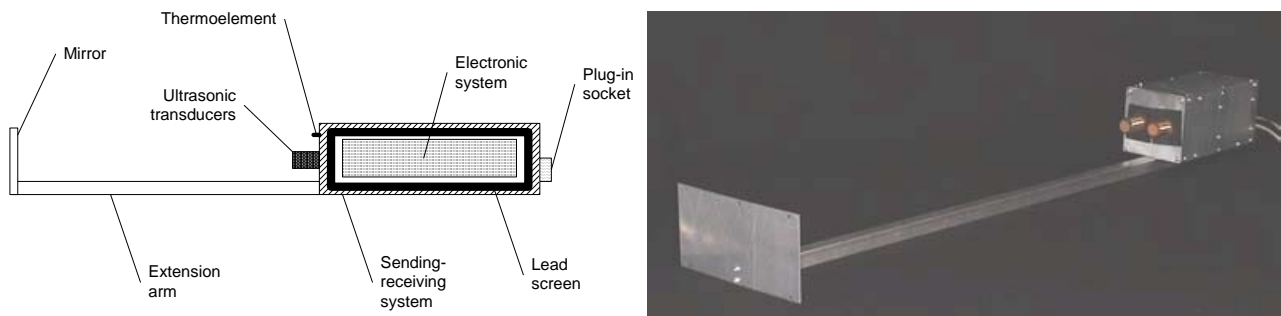

Figure 3. Schematic and general view of the sound-velocity measuring unit

After triggering the measurements by the control unit located in the SPS control room, the electronic system had to emit an ultrasonic burst and receive a signal reflected from the mirror. The received and processed signal was sent back to the control unit to evaluate time of wave propagation along a known distance. Additionally the unit was measuring a temperature of the air in the ultrasonic wave propagation area.

The electronic system of the emitter consisted of quartz stabilized frequency oscillator, modulo-16 counter, logical gate and power amplifier. The receiver path consisted of selective amplifier, amplitude detector and 2-threshold comparator.

The communication between the measuring unit and the control unit was made by a RS485 port. This was a current loop (4 - 20 mA) on electromagnetic interferences.

Figure 4 shows a block diagram of the electronic system of the measuring unit.

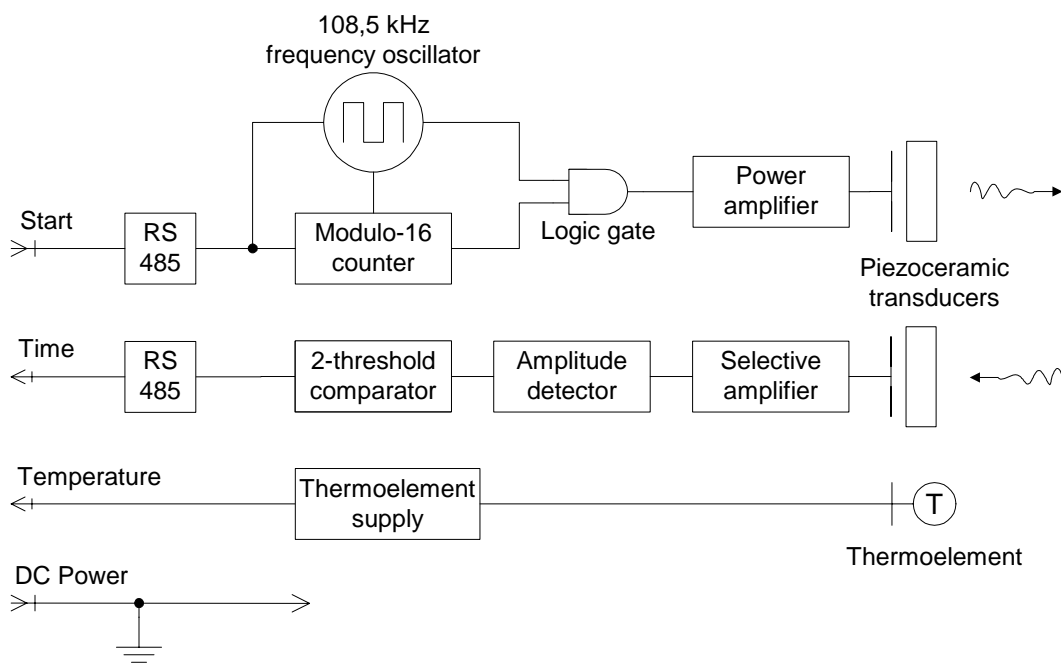

Figure 4. Block diagram of the electronic system of the sound-velocity measuring unit placed in the TCC2 irradiation zone

The electronic system of the control unit was made of a SIEMENS SAB 80537 microprocessor, E PROM chip, LCD, keyboard, communication ports to measuring unit (RS 485) and to computer (RS 232) and a power supply. A dedicated software was installed to start measurements in a specific period of time and to preliminary data handling. The operation of starting the measurement and reading out answers was repeated 100 times and then the microprocessor, using algorithm written in E-PROM chip, was computing average response time.

RESULTS

The results from both systems are given in Figure 5. The measured sound velocities are converted to the base temperature $T = 16 \text{ }^{\circ}\text{C}$. The obtained results are very close to each other and both systems gave satisfactory values. The two systems operated reliably for a similar period of time before they failed. Cumulative absorbed doses until failure for each measurement system was of about 70 Gy. The largest measured deviation in the average values of the measured propagation time was 0.08 ms in the case of the passive mode unit. This difference corresponds to helium concentration of about 4 % in the air and the corresponding oxygen concentration of 20.16 % (drop by 0.84 %). In the case of the active mode unit the largest measured deviation in the average value of the measured time of propagation was 0.02 ms (see Figure 6). The difference in this case corresponds to helium concentration of about 1 % in the air and the corresponding oxygen concentration of 20.79 % (drop by 0.21 %). The variations in the measured

propagation times correspond to the variations in oxygen concentrations in the air below 0.5 %. Hence the tested systems did not create a danger to trigger false alarms of ODH.

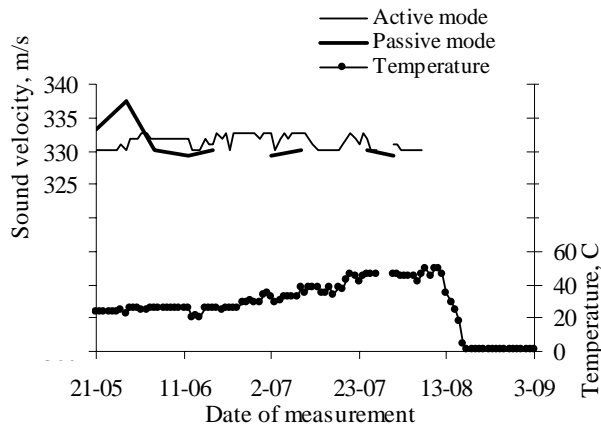

Figure 5. Results of passive and active mode systems, velocity of sound converted to the base temperature $T = 16\text{ }^{\circ}\text{C}$

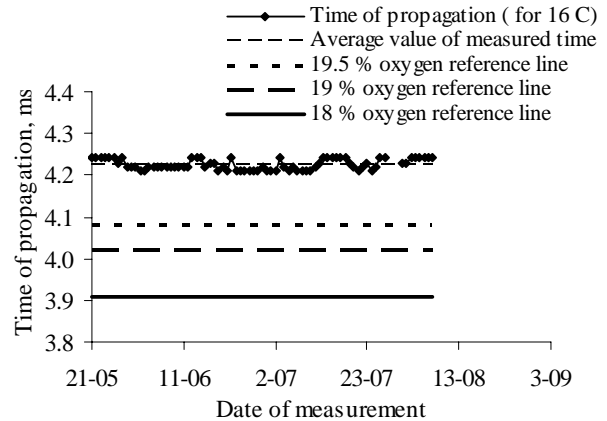

Figure 6. Comparison between average values of propagation time measured by active system and 18, 19 and 19.5 % oxygen concentration thresholds

CONCLUSIONS

Helium gas presence in the air can be detected directly by measuring sound velocity in the mixture. The performed experiments confirm theoretical dependence of the air/helium mixture sound velocity on the helium content.

Prototypes of the acoustic sensors to monitor helium presence in the air have been successfully tested in the TCC2 radiation test zone in an ionizing radiation environment similar to that predicted for the arcs of the LHC [3]. The accumulative absorbed doses, until the system failures, were of about 70 Gy. As the annual dose in the LHC arcs is of the order of a few Gy/year, this predicts the possibility of working for about 10 years in the LHC tunnel. Preliminary analysis of the failure reasons indicates a defect in piezoceramic crystal, caused by zirconium impurity excitation in the crystal structure. It can be concluded that continuous triggering of the active system did not cause additional danger of the electronics degradation, due to the ionizing radiation.

The oxygen concentration readouts were very stable and there is no danger to provoke false alarms of ODH. The developed technology can be considered to be used in the installations where the oxygen deficiency hazard can be result of helium relief to the air. This non-intrusive and quick way of measurement is an alternative for electrolyte oxygen sensors, which are characterised by a relatively long response time and in presence of helium may manifest erroneous behaviour [4].

ACKNOWLEDGEMENTS

Research performed in framework of collaboration agreement between European Organization for Nuclear Research CERN and Wroclaw University of Technology under the contract K944/AT/LHC. The authors thank Miguel Angel Rodriguez Ruiz for help in the measurements.

REFERENCES

1. Chorowski M., Lebrun Ph., Riddone G., Preliminary Risk Analysis of the LHC Cryogenic System, *Advances in Cryogenic Engineering 45B*, edited by Quan-Sheng Shu et al., Plenum New York, 2000, pp. 1309-1316.
2. Chorowski M., Gizicki W., Wach J., Application of acoustic tomography in helium-air mixture content monitoring, *Proc. ICEC 19*, edited by Guy Gistau Bague, Peter Seyfert, Narosa Publishing House, New Delhi, 2003, pp.671-674.
3. Fynbo C. A., Stevenson G. R., Qualification of the radiation environment in the TCC2 experimental test area, LHC Project Note 235, EST/LEA, CERN, Switzerland (2000).
4. Arenius D., Curry D., Hutton A., Mahoney K., Robertson H., Helium sensitivity in oxygen deficiency measurement equipment, Jefferson Lab, Newport News, USA (2001).