

PRINCIPLES AND PERFORMANCE OF THE CEE BEAM STRETCHING SYSTEM AT CERN SC 2

A. Fiebig, R. Hohbach, CERN, Geneva, Switzerland

Abstract

The design principles and first running experiences of the CERN SC 2 RF beam stretching system are described.

1. Introduction

1.1 Purpose of the installation

In order to cope with the enhanced characteristics of the improved CERN Synchrocyclotron, SC 2,<sup>1)</sup>

- higher beam current
- increased extraction efficiency
- higher pulse rate
- better definition of the beam
- higher acceleration voltage,

the radiofrequency beam stretching system, using a peripheral cee electrode, had to be reconstructed.

1.2 Design goal of the installation, comparison of essential data of the old and the new systems

Because of the expected tenfold increase of the beam current, resulting in a higher activation of the accelerator, it was desirable to remove as much as possible of the equipment out of the cyclotron hall. The higher pulse rate and the higher acceleration voltage on the dee electrode required a higher RF-voltage on the cee electrode, the smaller cross-section of the accelerated beam permitted a smaller radial extension of the cee electrode and a smaller frequency variation. The data of the old and the new systems are compared in Table 1.

Table 1 : Main Parameters of Cee-Systems of SC 1 and SC 2

	SC 1	SC 2
radial extension of cee electrode	36 cm	20 cm
azimuthal extension of cee electrode	42.5°	45°
effective capacitance	360 pF	150 pF
frequency range	16.5...19 MHz	16.77...17.48MHz
voltage on electrode, peak value	6 kV	20 kV
installed transmitter power	100 kW	220 kW

2. Technical Principle of the RF Amplifier

2.1 High Q, wideband coupling technique

For driving capacitive loads in a finite frequency band, various schemes are possible. The solution chosen for the main radiofrequency system was

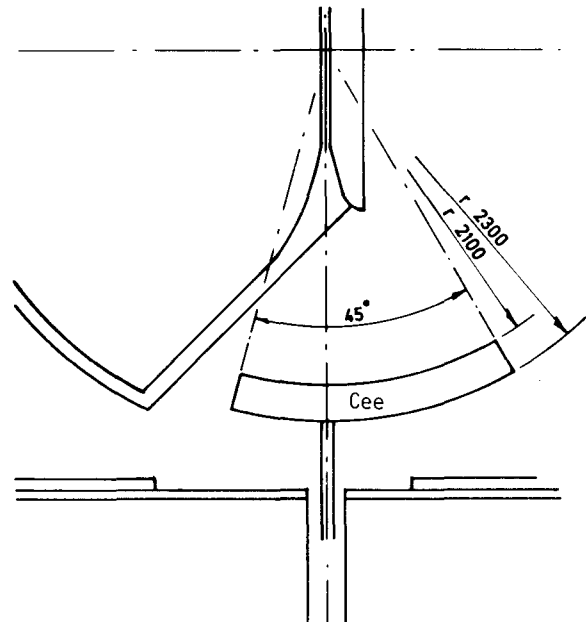

Fig. 1 Cee Electrode

that of a mechanically tuned resonant structure<sup>1)</sup>, offering the advantage of (relatively) small RF power, on the cost of inflexibility and considerable mechanical effort.

Ordinary wideband coupling with one or several, damped resonant circuits has the advantage of simplicity, but requires very large radiofrequency power. The solution which was finally adopted for the system was that of a three-circuit, high Q, coaxial line filter, which was used and proved its usefulness for the "old" slow extraction system. This is more difficult to design than a classical filter, but it yields a power economy of about a factor 3<sup>2)6)</sup>.

2.2 Coaxial line filter

The coupling circuiting between the final stage of the amplifier and the cee electrode was executed as a coaxial line filter, consisting of three mutually coupled resonators.

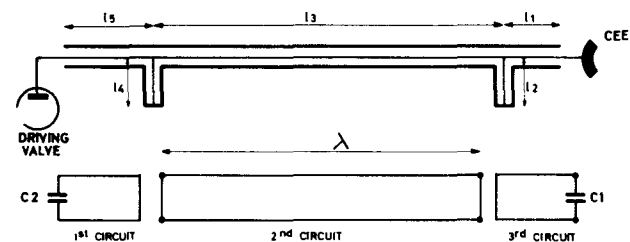
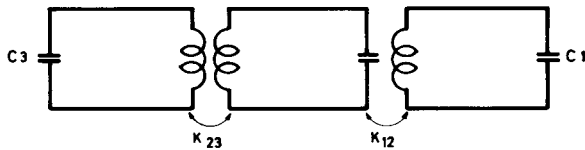

Fig. 2 Principle of Resonant Feeding Line



$C 1 = 195 \text{ pf}$     $C 3 = 632 \text{ pF}$     $K 12 = 29.327$   
 $K 23 = 29.331$     $Q 3 = 1000$

Fig. 3 Equivalent triple-tuned filter

All three resonators are tuned essentially to the same frequency, however, the two side resonators are considerably shorter than the centre one because of heavy capacitive loading. As it can be seen from the data in Fig. 3, the coupling stubs are rather short, particularly if one considers that, for reasons of high voltages and high currents (up to 25 kV and 500 A), the coaxial line had to have a rather large cross-section (100 mm outer diameter of the inner conductor, 272 mm inner diameter of the outer conductor). In order to avoid short  $60 \Omega$  T pieces which have a complicated current distribution and are not easily treated theoretically, near the T joints the characteristic impedance was reduced from  $60 \Omega$  to  $10 \Omega$ . Thus the length of the short-circuited sections was increased to values between 40 cm and 60 cm. Of course, the dimensions of the other sections had to be modified in order to keep the same transfer characteristics.

### 2.3 Geographical layout

The geographical layout of the coupling filter is shown in Fig. 4.

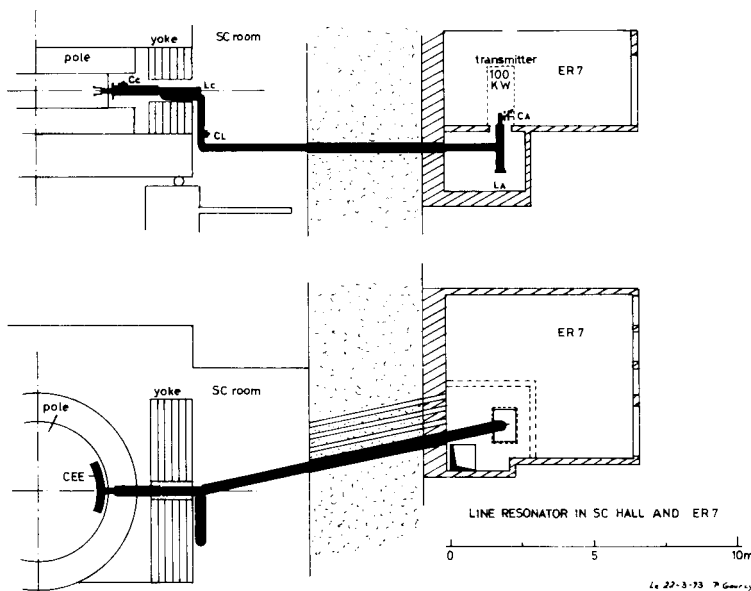

Fig. 4 Line Resonator in SC Hall and ER 7

As it can be seen, the great length (17.3 m) of the centre resonator permitted to locate the transmitter itself outside the cyclotron hall in a small annex building, equipment room 7. The coaxial

line, plus some water tubes and control and signal cables, traverse the wall of the cyclotron bunker below floor level. Even so, a part of the excess length of the resonator had to be executed as a U-shaped extension.

One other aspect of the layout can be seen in the upper part of Fig. 4. The line traverses the magnet yoke through an existing hole. In order to accommodate both the centre resonator line and the short-circuited coupling stub, the outer diameter was decreased and the two pieces of line were folded parallel. This could be done at that place, because the voltages are still rather low near the short-circuit, heating by large current was avoided by water-cooling of inner and outer conductors.

### 2.4 Tuning

In total, five tuning elements were foreseen : the length of the two short-circuited stubs was made adjustable, and, near the cee electrode and the transmitter anode, variable capacitors were installed. A third variable capacitor was placed at one quarter of the length of the centre resonator.

These five elements are sufficiently independent of each other to provide full adjustability of the filter : the three capacitors influence mainly the resonance frequencies of the three circuits, and the short-circuited stubs vary the mutual coupling. All tuning elements are remote-controlled.

A tuning procedure with low power which was worked out for this purpose not only allowed some preliminary adjustment of the line, but also permitted the personnel to acquire some routine for the final tuning which had to be done under full voltage conditions.

### 2.5 Some more aspects of the hardware

In the following photographs, some of the more important parts of the installation are shown.

Fig. 5 shows the cee electrode, being prepared for early power tests in a test tank. One should note the grounded dummy cees, the layout of the water cooling pipes and the spring contacts of the outer conductor and dummy cees, which establish connection to the pole pieces once the cee is in place.

In Fig. 6, one sees the cee electrode, supported by the vacuum tank window with which it forms a unit. It is supported on a rail system, which permits remote-controlled installation of the cee to the synchrocyclotron tank, and its removal. The two hemispheres below the cee are cups protecting the support insulators from deposits.

Fig. 7 shows the cee feeding line outside the yoke of the SC magnet. One can see the U-shaped extension, the transition to smaller diameter, and the two tubes which pass the hole in the magnet yoke. They are retractable from this position from the outside after pulling back the extension to the left.



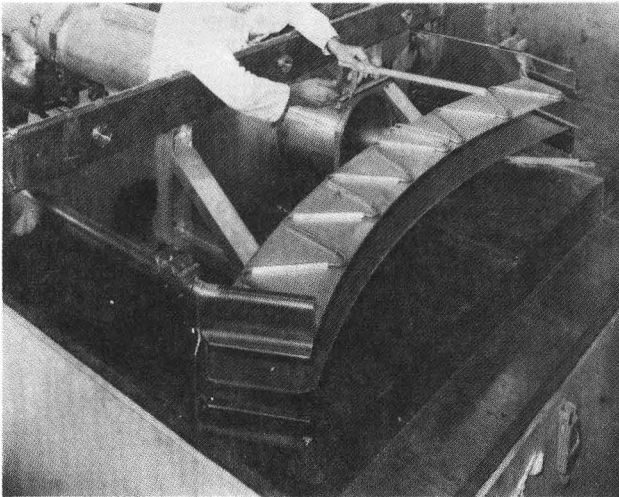

Fig. 5 Cee Electrode in Test Tank

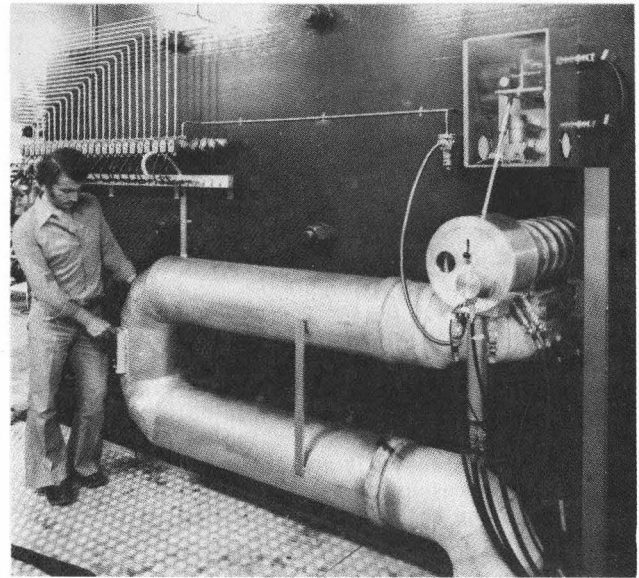

Fig. 7 Cee Feeding Line, and Extension

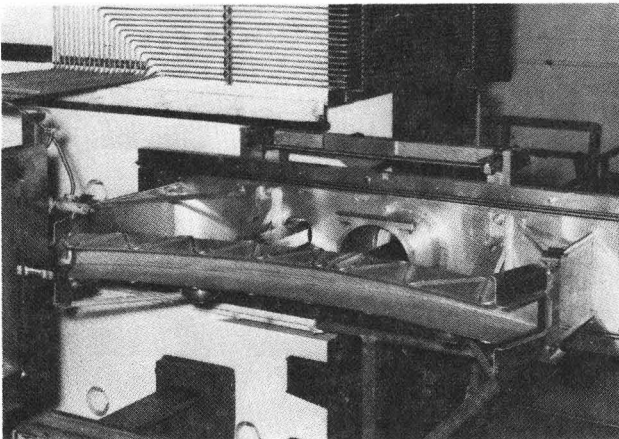

Fig. 6 Cee Electrode outside the SC Magnet

In the box above the hole in the yoke, two drive-units for the variable short-circuit and the cee-side variable capacitor are located.

The upper left compartment in Fig. 8 is the grid side of the 10 kW drive stage. The centre left compartment contains the anode side of this stage, and grid side of the final stage. The electric circuit is shown in Fig. 9.

### 3. Feeding, Control and Modulation

#### 3.1 Input data of the coupling resonator

As it can be seen from Fig. 10, the input admittance of the coupling resonator varies rather drastically with frequency. This is an inherent characteristic of a high-Q wideband filter. If the locus diagram would be a perfect circle, feeding from a generator with a constant real source admittance corresponding to the geometric means of the two real points on this circle would yield a constant input power, and, assuming that the losses of the filter

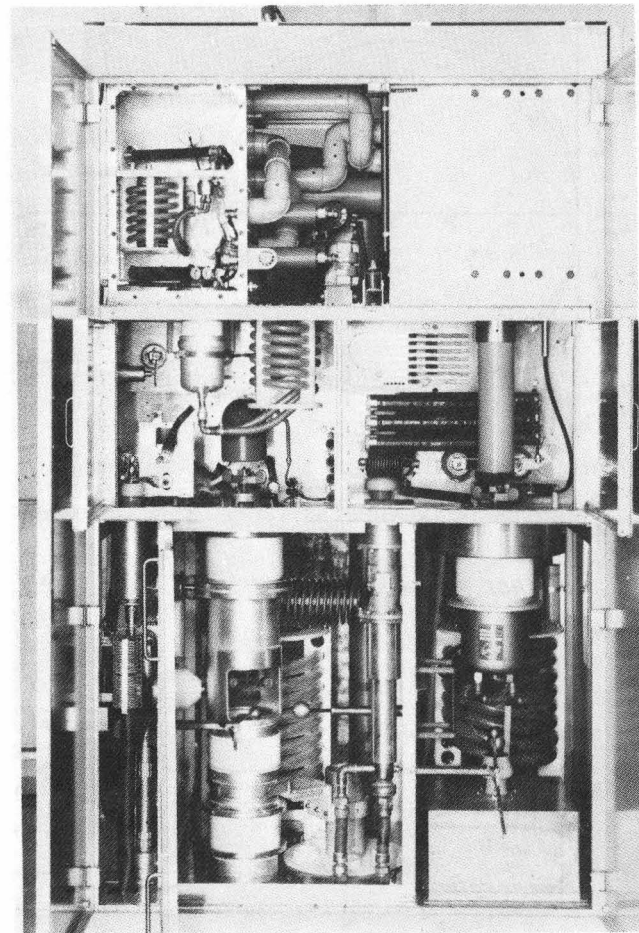
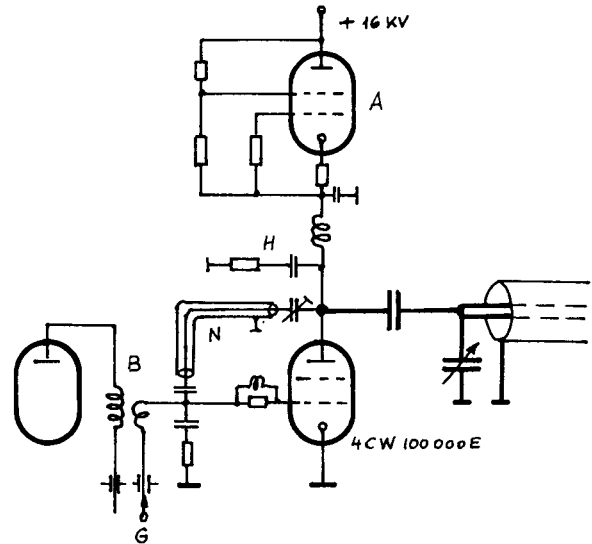

Fig. 8 View of High Power Stages of RF Amplifier

may be described by a resistance parallel to the cee electrode, constant output voltage. In practice, the driving valve will not have this source impedance, and other measures have to be taken to assure the proper values of input current and voltage as a function of frequency. (A constant source admittance, however, was used for low power tuning of the resonator).

To give an illustration of the requirements, the input data are shown in Fig. 11. The solution which was adopted was that of modulation, using a feedback circuit (Fig. 12). This permits not only to maintain a constant voltage on the cee electrode, but also an amplitude modulation programme.

The anode modulator, consisting of a second tube of the same type as used for the final RF stage, permits to reduce the anode voltage of the final tube for frequencies and/or voltages, where large current, but low voltage are required at the resonator input. This protects the final stage against excessive anode dissipation.



B = Bandfilter G = Input for G<sub>1</sub> Modulator  
 N = Neutralization by λ/2 Line H = Harmonic Absorber  
 A = Anode Modulator  
 Fig. 9 Final Stage

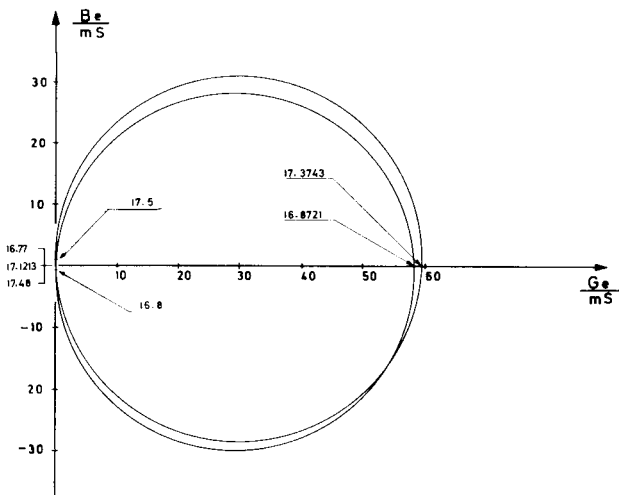

Fig. 10 Locus Diagram of the Input Admittance of the Line Resonator

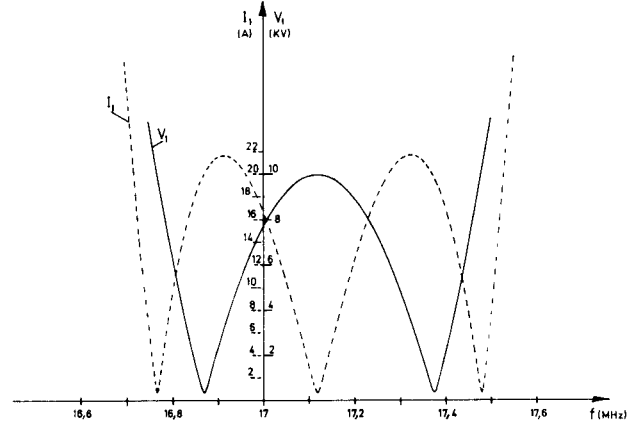

Fig. 11 Input Voltage and Current as Functions of Frequency

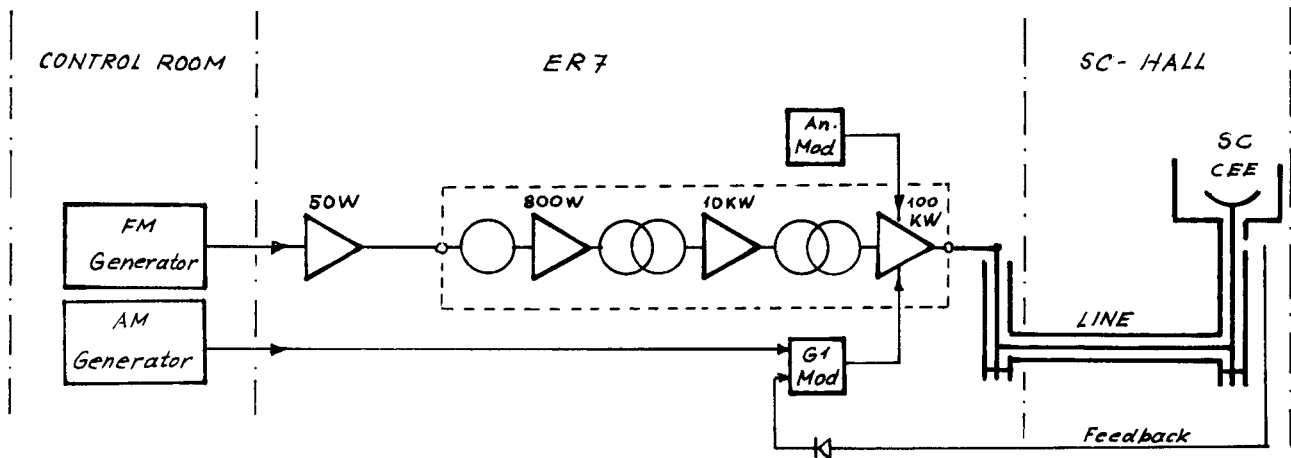

Fig. 12 Block Diagram of the Transmitter



### 3.2 AM and FM signal generator<sup>5)</sup>

This generator provides the signals to drive the amplifier, and the synchronisation to the Main Radiofrequency System. Normally, it will be synchronized to a pulse which occurs at the end of a cycle of the main system, the repetition rate of the generator being adjusted automatically to that of the main generator. The possibility of an additional adjustable delay is provided. Moreover, it may be set for fast cycling, providing 2, 3, 4 or 5 cycles per main RF cycle. Both the amplitude and the frequency function are composed of simple functions (square, positive or negative going sawtooth) and a number of triangular increments. All increments have the same duration, adjusting their values between a negative and a positive maximum yields a polygon function with a number of vertically adjustable edges, equal to the number of increments. This solution was chosen because it poses no problems with transients inherent to switching or diode network function generators.

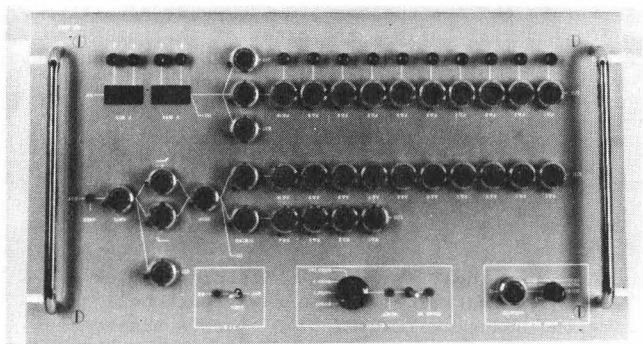

Fig. 13 Front Plate of AM and FM Generator

The amplitude function, which finally is fed into the differential circuit in the amplitude modulation loops, is composed of 4 parts :

- (a) the voltages at the beginning and the end of a cycle, which are independently adjustable;
- (b) a "rise" polygon, consisting of 4 individually adjustable increments;
- (c) a polygon superimposed on the trapeze function given by (a), which consists of 10 individually adjustable increments;
- (d) an external function.

For the frequency program generator both start and stop frequencies may be adjusted individually. This trapeze function may be superimposed by ten variable increments.

#### 4. Performance during First Test Runs

Power runs of the system in a test hall were rather limited in time, because the hall had to be evacuated for other parts of the SCIP. It could be shown, however, that the line filter performed according to specifications, and that it was possible to reach the design voltage on the cee electrode with the available transmitter power.

Longer tests with full power, however, could only be done after final installation of the system on the SC machine. During a continuous high power run early in 1975 discharges in the coaxial line occurred, probably due to metallic screws which had been left in some polyethylene insulators between inner and out conductors. These discharges set fire on the insulators, of which half a dozen were destroyed. After this event, the line was taken to pieces and cleaned thoroughly. The polyethylene insulators were replaced by teflon ones (first this had been avoided because of the poor radiation resistance of teflon), and all metallic screws were replaced by teflon screws.

Since then, the installation has performed satisfactorily. Due to the impossibility of adjusting the main accelerating system to an adiabatic stop<sup>3)4)</sup> at the wanted frequency, it was not yet possible to show that a nearly complete transfer of the beam from the main (dee) to the secondary (cee) system can be made. The flexibility of the program generator, however, enabled the system to be operated in an unsynchronized mode. In this mode, a beam transfer factor of about 65% was reached, with a macro duty cycle of about 5% in the extracted proton beam when the main RF system was energized at one pulse in 16. This presents a gain of a factor of about 60 compared to the duty cycle with the main acceleration system only. With internal target operation a duty cycle of 20% has been measured.

#### 5. Conclusions, Further Development

For the time being, no further development of the high power part of the installation is foreseen. It is, however, intended to develop a radiofrequency phase synchronization, between dee voltage and cee voltage. It is hoped that a transfer efficiency of nearly 100% can be achieved by this.

#### References

1. H. Beger et al, Design, construction and running of the new SC RF system, Contribution to the 7th International Cyclotron Conference, Zürich, 19-22 August, 1975.
2. A. Fiebig, RF broad-band amplifiers for driving reactive loads. CERN 64-27.
3. S. Lindbäck, On the operation of a cee in the improved synchrocyclotron, CERN MSC-69-1.
4. S. Lindbäck, Characteristics and tolerances on frequency and voltage programmes for the SCIP cee, CERN MSC M-1-70.
5. J.P. Tribolet, Générateur de fonction RF 4950, CERN MSC-M-5 20.9.1973.
6. I. Enchevich, Design of the Cee Resonance System for SCIP, CERN-MS-C-13, 1971.