

## BEAM CURRENT MEASUREMENTS FOR LEDA<sup>\*</sup>

J. Power<sup>+</sup>, D. Barr, J. Gilpatrick, D. Martinez, R. Shurter, and M. Stettler, LANL, Los Alamos, NM

### Abstract

Beam diagnostics systems for the Low Energy Demonstrator Accelerator (LEDA) at Los Alamos include beam current measurements [1,2]. The LEDA machine operates in both pulsed and cw modes with a peak current of 100 mA. Two types of current sensors are employed. Some are dc- to 4-kHz-bandwidth modular parametric current transformer (MPCT) sensors from Bergoz® and the others are 10-Hz to 200-kHz bandwidth custom-designed transformers. Both ac and dc sensors are integrated into common shielding enclosures on the beam line. A VXI module has been developed to interface the analog sensors to the EPICS control system. The same VXI module can be used for either type of sensor and contains an on-board calibration system which provides a system absolute accuracy of  $\pm 0.2\%$ . The calibration, data processing, and general operation of the VXI module is controlled by two internal DSP modules. The performance of the system on the LEDA beam line is presented.

### 1 INTRODUCTION

The beam diagnostics systems for LEDA are primarily VXI-based instruments. While the control system will soon be fully implemented under EPICS, we are presently operating the diagnostics systems under LabVIEW®. The beam current measurements are divided into two types; “ac” or pulsed beam systems with a 10-Hz to 200-kHz bandwidth and “dc” systems with dc- to 4 -kHz-bandwidth response. A single VXI motherboard is used as the backbone for both of these measurement types with different analog-front-end (AFE) electronics used depending on the requirements. We have chosen to use the modular parametric current transformer (MPCT) sensors and electronics modules from Bergoz® for the dc systems and custom transformers and AFE electronics for the ac systems.

### 2 BEAMLINE SENSORS

Both ac and dc sensors are enclosed in a common enclosure at each location on the accelerator. This enclosure is made of iron to provide some shielding from the various quadrupole magnet fields. A typical assembly is shown in Figure 1. Our present designs nest the ac toroidal core inside the dc sensor. Two sizes of Bergoz® sensors are used. We have 17.5-cm-o.d. and special-order 34-cm-o.d. units.

The ac sensors use 1-mil-thick Supermalloy® tape

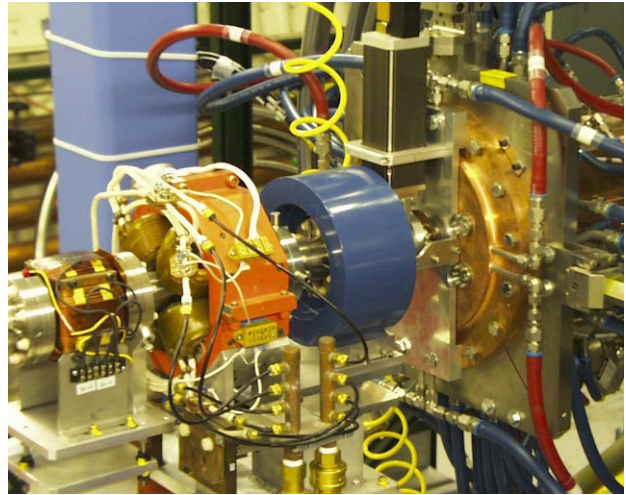

Figure 1: A typical beam current sensor assembly located at the exit of the RFQ. Both ac and dc sensors are contained in the same housing.

cores of an appropriate diameter to fit within the sensor housing. Each ac transformer has a 50-turn sense winding and two-turn calibration winding. The inductance of each sense winding is approximately 50 mH.

Both sensors are supported in the housing with felt material to help absorb vibrations on the beamline from the vacuum pumps.

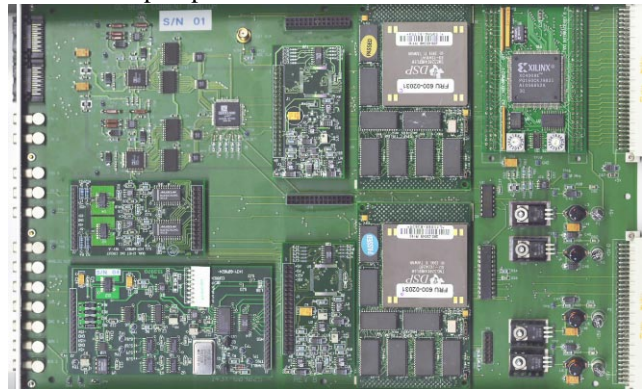

Figure 2: The VXI motherboard printed circuit shown with two ac AFE circuits installed in the middle of the motherboard. The 14-bit ADC circuits are at the top left, DAC and calibrator at the bottom left, and the DSP modules just right of center. The VXI interface and power supply components are on the right.

### 3 VXI MODULE DESIGN

A single VXI format motherboard was developed for both the ac and dc measurement systems. A modular approach allows for the replacement or revision of sub-circuits to avoid the expense and time required in fabricating a full

<sup>\*</sup>Work supported by the U.S. Department of Energy

<sup>+</sup>Email: jpower@lanl.gov

VXI module (see Figs. 2 and 4). Various plug-on modules include the ac AFEs, dc Bergoz® AFEs, a wire scanner charge-integrating AFE, calibration current generator, dual output DAC circuit, two DSP modules, and the VXI interface circuit. Each motherboard supports two channels of beam current measurement. Electronics associated with the motherboard include various gate arrays for interfacing the modules, two 14-bit ADC channels, timing generation gate arrays, and power supply components.

Two commercial DSP modules (TMS320C40), one per channel, control the operation of the module. Functions provided by the DSPs include module calibration, fast-protect calculation, waveform array storage, and filtering. The most demanding feature of the DSP is the fast-protect output, which is tripped whenever the differential beam loss between to adjacent sensors exceeds a programmable level. The VXI motherboard design and DSP code is heavily influenced by this requirement.

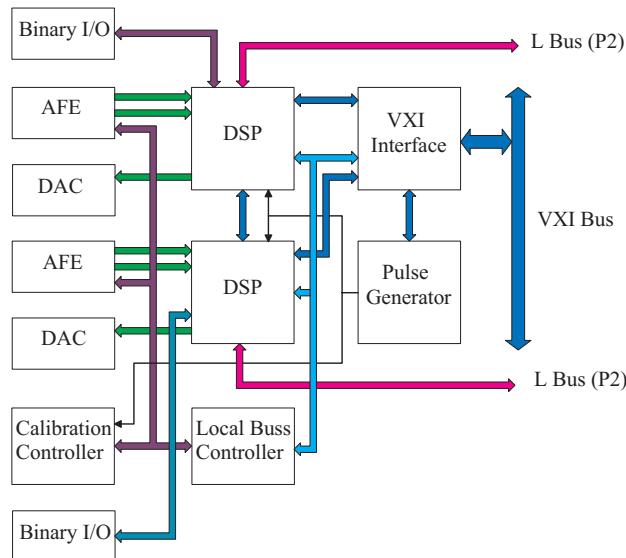

Figure 3: Block diagram of the ac/dc VXI module. Each measurement channel has a dedicated DSP module and DAC. Plug-on modules are controlled via a local buss.

Most of the plug-on modules are connected with an eight-bit buss whose purpose is to allow set-up, and control data to flow between them and either the DSP modules or the VXI interface. Separate dedicated busses control the flow of the realtime data streams. A block diagram of the VXI module is shown in Figure

The most significant difference between the implementation of the ac versus the dc systems is the size of the AFE electronics. The Bergoz® MPCT-E electronics modules are sufficiently large as to require a double-wide-module front panel for the two-channel design (see Fig. 4). Another interesting point is that ADC sampling rate required for the lower 4-kHz bandwidth of the dc system will leave more time available to the DSP modules to perform additional calculations such as additional filtering functions. The dc systems have not been fully implemented at this time, as the LEDA

accelerator is being commissioned with pulsed beam. These dc systems will be significantly easier to field than the faster ac systems, however.

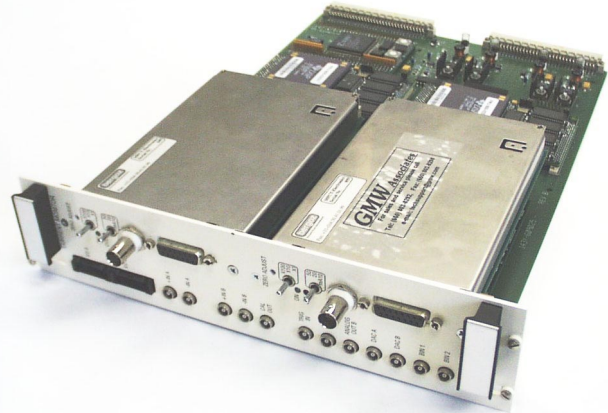

Figure 4: The dc beam current system double-wide VXI module. Two Bergoz® MPCT-E electronics modules are mounted to the front panel. Only the sensor cables need to be attached to the front panel connectors. The ac system uses a single-wide module with the same motherboard.

#### 4 OPERATIONAL EXPERIENCE

As of this writing we have just completed the first two weeks of LEDA accelerator commissioning. This time has been sufficient to measure several important parameters of both the diagnostic systems as well as the accelerator operation.

As installed, the ac system has a current measurement range of  $\pm 200$  mA. In this configuration the noise floor of the current measurement is about  $33 \mu\text{A}$  with a 200 kHz bandwidth. This is measured as the standard deviation of 1000 consecutive samples at 1 MSPS. The overall bandwidth of the three operating ac systems is 8.7 Hz to 200 kHz, worst case. The bandwidths vary slightly as all of the sensor cores are not of the same geometry.

Each VXI module generates a single calibration pulse that is looped between two adjacent sensors. The stability of this source needs testing over temperature, but is at least much better than the  $\pm 0.2\%$ -absolute-accuracy specification of the diagnostic. Our present laboratory instrumentation measurement limit is  $\pm 0.04\%$ , absolute. Each beamline measurement system is calibrated to within  $\pm 1$  ADC count, or  $\pm 0.02\%$  of the set points (gain and offset). The system has demonstrated a stability of on the order of  $\pm 2$  ADC counts over the two week run period, so far. It should be noted the temperature is fairly constant in the accelerator building this time of year. Overall, we are confident that the required  $\pm 0.2\%$  measurement accuracy is met.

We are presently running the beam diagnostics systems under LabVIEW® while the EPICS-based control system is being completed. A single National Instruments VXIpc-850 controller in the ac beam current measurement VXI

crate handles the control, display, and data archiving functions of the system running LabVIEW® under Windows 95. The primary display is shown in Figure 5 with typical beam currents as seen during one of the first LEDA commissioning experiments.

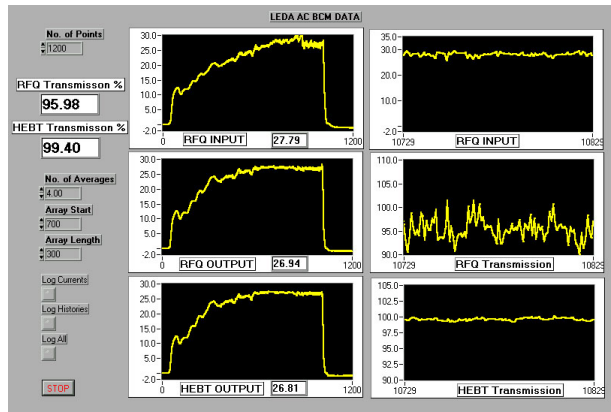

Figure 5: The LabVIEW virtual instrument front panel display for the ac beam current monitor system. The RFQ input, RFQ output, and HEBT output current waveforms are displayed on the left and the RFQ input current, RFQ transmission, and HEBT transmission charts are on the right.

## 5 CONCLUSION

New beam current diagnostics have been designed for the LEDA accelerator. The ac (pulsed beam) system has been installed, tested, and has provided the required performance needed to commission the accelerator. It is capable of measuring  $\pm 200$ -mA pulsed currents with an absolute accuracy of  $< \pm 0.2\%$  with a resolution of about  $33 \mu\text{A}$  (without gain switching) and a 10-Hz to 200-kHz bandwidth. Both the ac and dc systems utilize DSP-based VXI modules, which provide high-performance and ease of use.

## 6 REFERENCES

- [1] J. D. Schneider, et. al., "Operation of the Low-Energy Demonstration Accelerator: the Proton Injector for APT," these proceedings.
- [2] J. D. Gilpatrick, D. Barr, J. Power, W.C. Sellyey, R. Shurter, J. Kamperstroer, D. Martinez, and J. O'Hara, "Low Energy Demonstration Accelerator (LEDA) Beam Instrumentation: RFQ-Accelerated Beam Results" these proceedings.