

A Flying Wire System in the AGS*

H.Huang[†], W. Buxton, G. Mahler, A. Marusic, T. Roser,
G. Smith, M. Syphers, N. Williams, R. Witkover
Brookhaven National Laboratory, Upton, NY 11973, USA

Abstract

As the AGS prepares to serve as the injector for RHIC, monitoring and control of the beam transverse emittance become a major and important topic. Before the installation of the flying wire system, the emittance was measured with ionization profile monitors in the AGS, which require correction for space charge effects. It is desirable to have a second means of measuring profile that is less dependent on intensity. A flying wire system has been installed in the AGS recently to perform this task. This paper discusses the hardware and software setup and the capabilities of the system.

1 INTRODUCTION

The primary method for measuring the beam profile in the AGS has been through the use of an Ionization Profile Monitor (IPM).[1] Another method which has been used with some success in the AGS Booster is one in which the RF is turned off and the beam is allowed to spiral inward as the magnetic field is varied; the beam intercepts a scraper and the beam loss is measured versus time.[2] Analysis of this data can also give the beam profile. However, this scheme only works for measuring horizontal beam distributions.

Since the optical properties of the AGS are fairly well understood, a measurement of the beam profile with the IPM monitors can give information about the emittance of the beam. In the vertical, this is a direct measurement. However, in the horizontal, one must fold in the spread in beam size due to the spread in momentum of the beam particles and the non-zero dispersion of the ring. Moreover, the IPM measurements require space charge corrections, which makes the measurement sensitive to beam intensity. Such corrections can be implemented but require frequent calibration of the system high voltage to obtain accurate measurements.

Flying wires ("wire scanners") have been widely used to measure the transverse beam profile at many other proton accelerators such as CERN PS and SPS, KEK, FNAL and LANL. A flying wire system consists of a thin wire which traverses the beam with constant speed and a detector which measures the scattering of the beam caused by the wire. Since the scattering is proportional to beam intensity at a particular wire position, the detected scattering versus the wire position gives the transverse beam profile.

Placement of a flying wire profile monitor in the AGS

allows for a non-destructive, independent means of measuring the transverse beam size and cross-calibrating the AGS IPM. Since the AGS accelerates protons and heavy ions, it is desired that the flying wire measures emittance for both scenarios. For heavy ion beams, because of the stripping that can occur as the wire intercepts the beam, it obviously would not be unobtrusive. For proton beams, however, especially high intensity beams where the space charge effects of the IPM are questioned, the wire could prove beneficial. However, wire survival may be compromised with high intensity beams due to wire heating.

1.1 Heating of the Wire

To estimate the temperature rise in the wire, we assume that the particles lose energy in the wire due to ionization losses and that some fraction e_h of that energy remains in the wire. This implies that the temperature rise will be approximately

$$\Delta T \approx \frac{e_h \frac{dE}{dx} N_p f_0}{\sqrt{2\pi} \sigma_y \rho c_s v},$$

where dE/dx is the energy loss per unit length due to ionization, N_p is the number of particles in the ring, σ_y is the rms beam dimension in the direction along the wire, ρ is the density of the wire material and c_s is the specific heat of the wire material.

Measurements have been made at CERN[3] to determine a value for e_h and its value was found to be roughly 0.3. Their measurements also showed that the wire would break due to beam heating at speeds less than about 1 m/s for total beam intensities of 2×10^{13} protons. If a similar wire system were used in the AGS, then the speed below which the wire would break at intensities of 7×10^{13} would be approximately

$$\begin{aligned} v &\approx (1\text{m/s}) \times \frac{7 \times 10^{13}}{2 \times 10^{13}} \times \frac{0.5\text{mm}}{2\text{mm}} \times \frac{6200\text{m}}{807\text{m}} \\ &\approx 7\text{m/s}, \end{aligned}$$

where a Gaussian beam with emittance $\epsilon_N = 50\pi$ mm-mr beam in the AGS is assumed. This speed is easily within the range of present systems. In reality, the AGS beam size is estimated about $\epsilon_N = 100\pi$ mm-mr. If one anticipates higher intensities, then a system which can attain 10 m/s wire speeds is in order.

Radiative cooling also helps in this regard. As the wire heats up, it will radiate as an inefficient "black-body." Suppose a wire with the same parameters as the CERN wire

* Work supported in part by the U.S. Department of Energy.

[†] Email:huanghai@bnl.gov

system is used in the AGS at a location where the amplitude function is $\beta_x = \beta_y = 15$ m. At the highest AGS momentum 29 GeV/c, the temperature rise in the center of the wire for the passage through a Gaussian beam with emittance $\epsilon_N = 100\pi$ mm-mr at speed of $v = 7$ m/s is about 2100K.

1.2 Emittance Dilution Estimates

Due to Coulomb scattering, passing a wire of diameter d will increase the emittance of the beam. The amount of emittance increase can be estimated by considering the wire to pass through the beam with speed v at a location where the amplitude function has value β_0 . Then, the increment in emittance due to a single scan of the wire is

$$\Delta\epsilon_N = \frac{6\pi\beta_0 d^2 f_0}{\beta^3 \gamma L_{rad} v} \left(\frac{15}{938} \right)^2$$

where f_0 is the revolution frequency, β and γ are the relativistic kinematic factors, and L_{rad} is the radiation length of the wire material. Inputting the AGS parameters used above, and assuming a $33\mu\text{m}$ carbon fiber, the emittance increase using a speed of 7 m/s would be approximately $\Delta\epsilon_N = 3.4\pi$ mm-mr at injection (1.9 GeV/c), and 0.2π mm-mr at 29 GeV/c.

Based on the analyses described briefly above, it appears that a $33\mu\text{m}$ diameter Carbon filament, traveling at speeds greater than above 7 m/s would survive crossing an AGS beam of 7×10^{13} protons with normalized transverse emittances of 100π mm-mr.

2 THE AGS FLYING WIRE SYSTEM CONFIGURATION

2.1 Flying Wire System

The AGS flying wire beam profile monitor system is located in a 10-foot straight section of the AGS, A20. One vacuum chamber hosts both the horizontal flying wire and the vertical flying wire, sitting upstream and downstream, respectively. A scintillator paddle installed down stream is used to measure the beam scattering due to the interaction with the wire. It can measure beam profile in horizontal and vertical directions, but only one direction can be measured at a time. The scintillator paddle is 1.2 m down stream from the vertical flying wire and 1.5 m down stream from the horizontal one.

Two rotary stepping motors are used to move the horizontal and vertical wires through the beam. Each motor rotates a shaft with two wires stretched between the ends. The angle between wires is 120 degrees. One of the wires on the same shaft is considered a spare. The motor takes the wire from its parked position outside the beam, accelerates it to desired speed, sweeps it through the beam, and decelerates it to a stop at the other side of the beam. There exists no mechanical interference between the wires in horizontal and vertical directions. The scattering caused by the

passage of any of the wires through the beam is measured with the same photo multiplier. Therefore only one wire can be moved through the beam at one time. The wires can rotate full rotation in 5000 steps. At their desired speed of 10 m/s, wires travel 0.2 mm in 20 us.

2.2 Detector and Readout

The detector for the flying wire is a scintillation counter. The scintillation material is Bicron, BC-408. The counter paddle has a circular cutout at its end so that the scintillator can straddle the vacuum pipe and intercept a 180 degree, one inch wide arc in the beam scattered in the forward direction. A light guide about one foot long is used to guide the light to an XP2203B ten stage photo multiplier tube. The whole assembly, tube base and all, is enclosed in a metal shield to provide for the best possible noise rejection. An LED was added in the light guide to provide for testing in place.

Discrete counting is not possible due to the beam bunching, therefore, the analog charge signal from the PMT must be used. The XP2203B has an S20 photo cathode assuring the largest signal and best overall linearity. A resistor divider in the tube base provides the tube bias to the dynodes. Two bases are available: one for high intensity, which uses five dynodes and takes the output from the sixth; the other for low intensities, which uses all ten dynodes taking the output from the anode. Much of the base and paddle design was fashioned after a design used in the FNAL flying wire system [4],[5] and we are grateful for their help.

Signals from the PMT are read differentially by a VME module. This module is a BNL design known as an MADC (Multiplexed Analog to Digital Conversion System). Running at full speed, this module provides digital signal samples to the AGS Control Computer.

2.3 Software and Controls

An Oregon Micro Systems VMEX-2E Motor Controller board is used for the control of the motors. It can control 2 axes of motion while monitoring their actual positions with the built in incremental encoder interface. The board has a Motorola 68000 processor which can be programmed to execute a wide variety of motion commands. A sync line is available to synchronize moves to external events and there is an auxiliary line for each axis which allows the control of external events. The start of flying wire movement is initiated by V102 Event Link Delay Module. Motion signals generated by the motor controller board, besides being used for motor control, are used as external scan trigger signals to MADC module.

All signals generated by or going to the motor controller board go through a transition module. The operation mode of the transition module is determined by the state of the motor controller X and Y auxiliary lines. When the auxiliary line for one of the axes is set to the high level, the transition module will allow that axis of motion to operate as the sync line becomes active. The transition module will

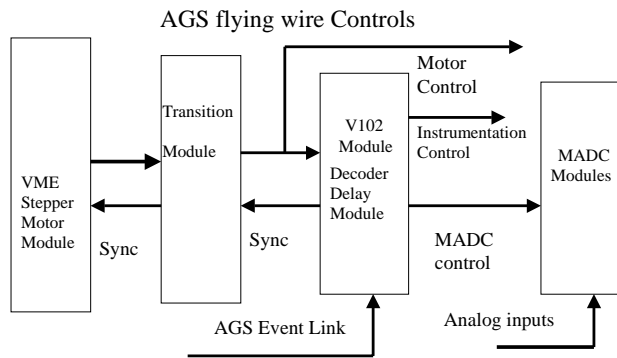

Figure 1: The AGS flying wire control sequence diagram.

also send signals to the MADC to take data. When both auxiliary lines are set high then the transition module will only send signals to the MADC and not allow either motor to move. The purpose of this mode of operation is to take background measurements.

The control sequence is shown in Figure 1. Beginning with the sync signal, the V102 decodes an event from the AGS event link and delays a programmable amount of time and then generates the sync pulse. When the VME stepper motor module receives the sync signal it begins to execute code that determines the direction of the appropriate motor and outputs the clock to step either the X or Y plane motor. The transition module passes the motor step clock and direction signals to the appropriate motor indexer and the step clock to the V102 module. The motor step clock is used by the V102 to generate programmable delayed signals which in turn control the instrumentation electronics and the MADC. The MADC digitizes the analog data on every step of the motor while the wire is in the beam. The VME stepper motor module automatically accelerates the motor to the correct velocity, runs the motor at a constant velocity through the beam and decelerates the motor after the wire leaves the beam.

3 PERFORMANCE AND FUTURE

The flying wire system has been tested during the AGS FY99 high intensity proton run. A horizontal beam profile measured with the AGS flying wire is shown in Figure 2. Due to the proximity of the detector to the AGS Ring, and the remote location of the electronics, noise pickup from the beam and other devices is a significant problem. A large fraction of the noise is rejected by the differential input of the MADC. The rest can be filtered effectively by proper DSP techniques.

The flying wire system in the AGS provides a simple

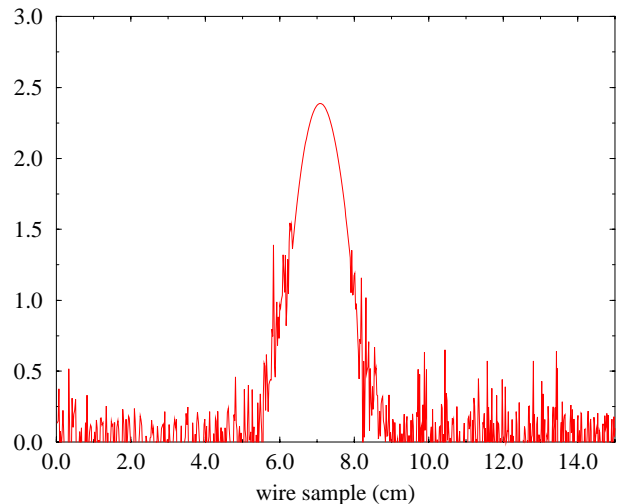

Figure 2: The horizontal beam profile measured with the AGS flying wire.

precise means of measuring beam profiles. We plan to run it utilizing other species such as heavy ion and low intensity polarized proton beam in the AGS in the future. It will become a valuable tool for AGS beam diagnostics.

4 REFERENCES

- [1] A. N. Stillman, R. Thern, and R. L. Witcover, *Rev. Sci. Instrum.* 63, 3412 (1992); A. Stillman and R. E. Thern, "Full Cycle Beam Diagnostics with an Ionization Profile Monitor," *Proc. 1993 IEEE Part. Accel. Conf.*, p. 2471.
- [2] K. Zeno, AGS Studies Report No. 314.
- [3] A. Burns, et al., "Wire Scanner News from the CERN-SPS," *Proc. 1989 IEEE Part. Accel. Conf.*, Chicago, p.1580(1989).
- [4] W. Blokland, et al., "New Flying Wire System for the Tevatron", *Proc. of the 1997 IEEE PAC*, pp. 2032-4, May 12-16 1997, Vancouver, B.C.
- [5] J. Zagel, et. al, "Upgrades to the Fermilab Flying Wire Systems," *1991 IEEE Part. Accel. Conf.*, 91CH3038-7,p.1174-6 (1991).