

## THE SNS FOUR-PHASE LEBT CHOPPER\*

J. W. Staples, J. J. Ayers, D. W. Cheng, J. B. Greer, M. D. Hoff, A. Ratti  
 Ernest Orlando Lawrence Berkeley National Laboratory  
 University of California, Berkeley, CA 94720, USA

### Abstract

The Spallation Neutron Source front end incorporates a beam chopper in the LEBT that will remove a 295 ns section of beam at a 1.118 MHz rate (65% transmission) with less than 50 ns rise/falltime. The  $H^-$  beam pulse length is one ms at a 60-Hz rate (6% duty factor). The LEBT is all-electrostatic, and the chopper incorporates four 3-kV solid-state switches driving an einzel lens, split into quadrants, with a 4-phase chopping waveform. The suppressed beam is targeted on a four-segment Faraday cup which provides on-line intensity and steering diagnostics. Results of proton beam tests will be reported.

### 1 BEAM REQUIREMENTS

The Spallation Neutron Source (SNS) comprises a 1-GeV  $H^-$  linac injecting a storage ring with a 1 ms injection time and single-turn extraction, operating at 60 Hz[1]. During the 1 ms injection into the ring, approximately 1200 turns are accumulated. To reduce the activation of the extraction Lambertson septum magnet, a 295 ns notch is introduced in the injected beam by two sets of choppers, operating at the ring revolution frequency of 1.188 MHz.

### 2 IMPLEMENTATION

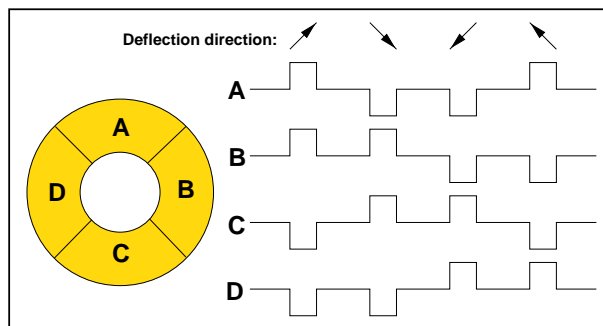

Figure 1: Waveforms to Deflector

The first chopper stage is at the end of the 65-keV all-electrostatic LEBT[2], followed by a fast-rise clean-up chopper at 2.5 MeV. The LEBT chopper is included as a modification of the second LEBT einzel lens, which is split azimuthally into four quadrants. A four-phase chopping

waveform on the four segments deflects the beam sequentially in four directions, shown in Figure 1, creating the 295 ns gaps in the 1 ms beam pulse. The four electrode segments are each independently pulsed to  $\pm 3$  kV by solid-state switches, deflecting the beam sequentially along each of the 45 degree diagonals. The solid-state switches have active pull-up and pull-down, providing a less-than 50 ns chopping transitions.

Figure 2 shows an early version of the split einzel electrode.

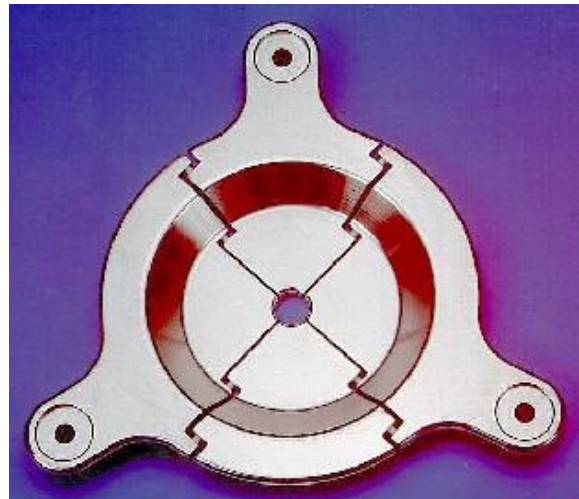

Figure 2: Split Chopper Electrode

The beam is targeted onto a diagnostic plate, split along the diagonals similar to the chopping electrode itself, in the wall common to the end of the LEBT and the start of the RFQ. The four segments of the target electrode are electrically isolated and water cooled, serving as a beam current diagnostic and a beam steering diagnostic. For a 65 keV, 35 mA  $H^-$  beam with a 65% duty factor and with 35% of the current removed by the 1.188 MHz chopper, the total average power dissipated on the target is 48 watts.

Angular beam steering is provided by a symmetric d-c bias on each segment of up to  $\pm 1$  kV. Beam position steering is provided by physically moving the entire ion source and LEBT relative to the RFQ and the diagnostic plate on a sliding vacuum seal.

### 3 ELECTRONICS

The key electronic component of the LEBT chopper system is the solid-state  $\pm 3$  kV bipolar switch. This switch is

\* This research is sponsored by the Director, Office of Energy Research, Office of Basic Energy Sciences, of the U. S. Department of Energy, under Contract No. DE-AC03-76SF00098.

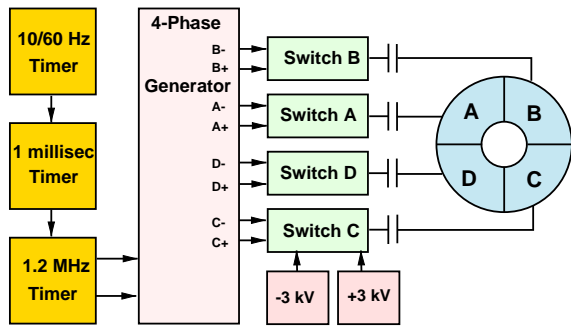

Figure 3: Chopper Block Diagram

a modified version of a standard product from Directed Energy Inc.[3]. The DEI design provides rise and fall times of less than 60 ns and a duty cycle of up to 12% at 60 Hz for up to a 2 ms burst. The switch design is protected against load faults (sparking) and mis-timed or incorrect gating of the positive and negative gate inputs.

The major internal power dissipation of the solid-state switches occurs at the voltage transitions. The average power dissipation is less than 450 watts per switch at a 12% duty cycle.

Figure 3 shows the control logic used during the test phase. Figure 4 shows a detail of the actual equipment: two of the four DEI bipolar solid-state switches, topped by a four-phase waveform generator.

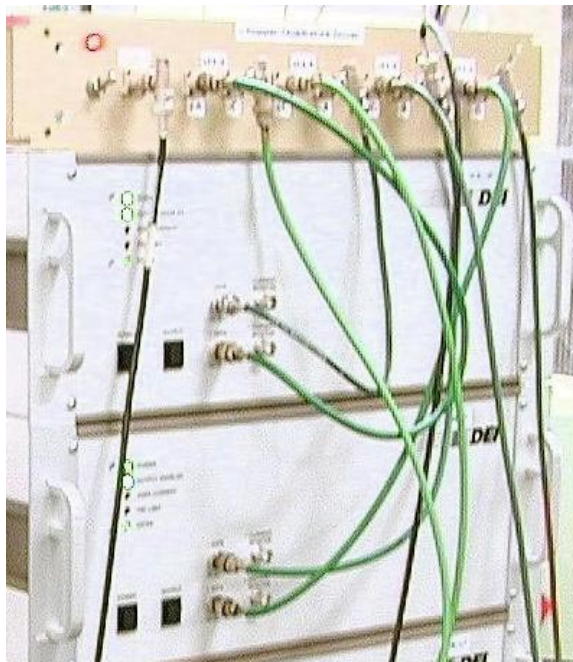

Figure 4: Chopper Switches and Driving Electronics

The electronics used during the test phase includes a series of delay/gate generators and a 4-phase generator that drive the inputs of the DEI switches. The high-voltage bipolar output is delivered to the electrodes via coupling capacitors, allowing the switches to be at ground potential,

isolated from the steering offset and accelerating potentials. The rise and fall times are specified for a load capacitance of 100 pf along with a four-foot length of coax interconnect cabling of an additional 100 pf.

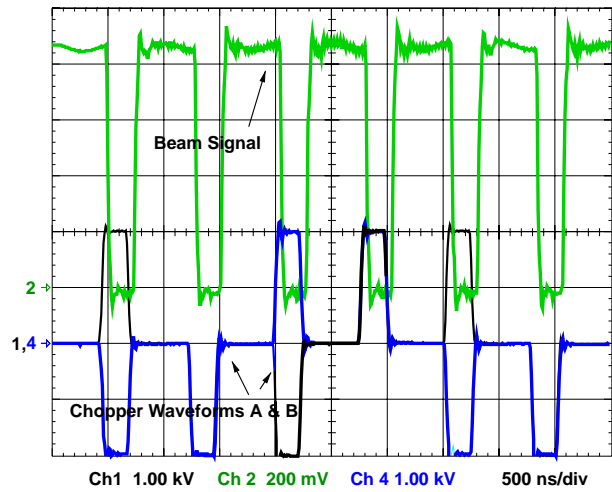

Figure 5: Deflection Waveforms, Beam Current, 500 ns/div

#### 4 PROOF OF PRINCIPLE

A proof-of-principle test has been conducted on a 40 keV proton injector that includes all the elements in the SNS source/LEBT design: an r.f.-driven multicusp ion source and a two-einzel lens all-electrostatic LEBT. The LEBT is followed by an aperture plate and a fast 50-ohm Faraday cup.

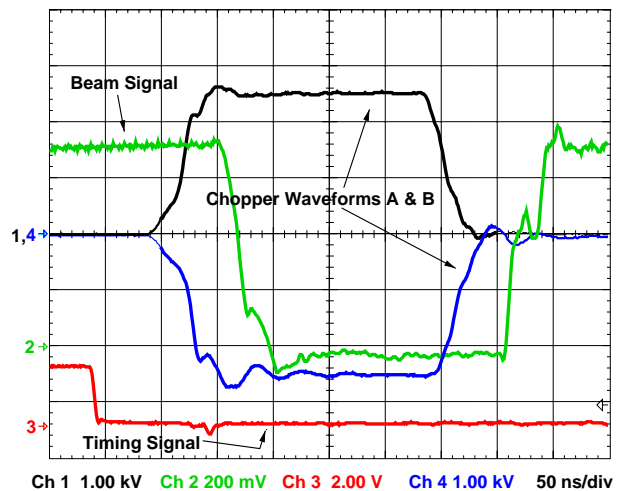

Figure 6: Deflection Waveforms, Beam Current, 50 ns/div

Figure 5 shows the beam current (upper trace) and the chopping potentials on two adjacent chopper segments (lower traces) at 500 ns/div. The peak deflection voltage is  $\pm 2$  kV and the pulse period is 0.75 microseconds. In Figure 6, the time scale is expanded to 50 ns/division and the chopping voltage increased to  $\pm 2.5$  kV, showing the

risetime (center) is less than 50 ns, and the beam rise and falltime also less than 50 ns. The transit time of the beam through the last einzel electrode is 12 ns, which sets a lower limit of the chopping transition time.

Note in Figure 5 that the chopped beam time structure exhibits no subharmonic of the chopping frequency, even though the beam is sequentially chopped in four directions. For a lower chopping voltage where the beam is only partially chopped, the subharmonic amplitude of the partially chopped current is a sensitive indication of beam missteering on the chopping aperture.

## 5 SNS CHOPPER CONFIGURATION

Figure 7 shows a cross-section of the LEBT electrodes, starting at the plasma generator at the left [4],[5], [6] and continuing to the diagnostic plate (RFQ endwall) at the right, spanning a 10 cm total length. The last electrode (G5) before the RFQ endwall is the split deflection electrode that also acts as the second einzel focusing electrode.

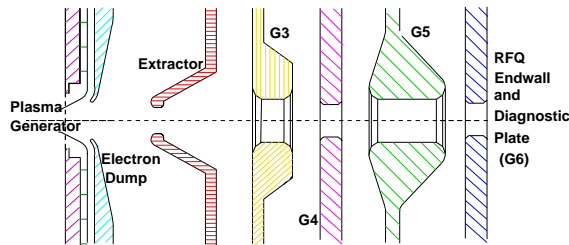

Figure 7: LEBT Electrode Configuration

Figure 8 shows a three-dimensional simulation (SimIon) of the beam deflection by the chopper electrode, deflected toward the chopping aperture plate (G6) and the following RFQ[7]. In the final configuration, the aperture plate hole radius is equal to the envelope radius of the beam passing through it. With this aperture radius, 85% of the deflected beam will be lost on the diagnostic plate, and the remaining 15% of beam will be deflected *between* the RFQ vanes and will not be accepted for acceleration by the RFQ.

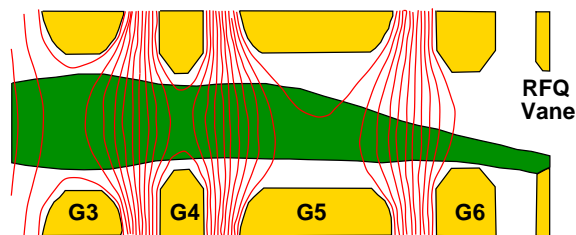

Figure 8: Deflected Beam Profile (From SimIon Plot)

Figure 9 shows the diagnostic plate detail with the pick-up electrodes sandwiched between the LEBT ground plane and the RFQ end plate. The diagnostic plate is constructed of layers of metal and thermally conducting epoxy, one millimeter thick. The pick-up electrodes comprise two brazed-

together layers of OFE copper and contain water cooling passages (not shown) surrounded by an air guard.

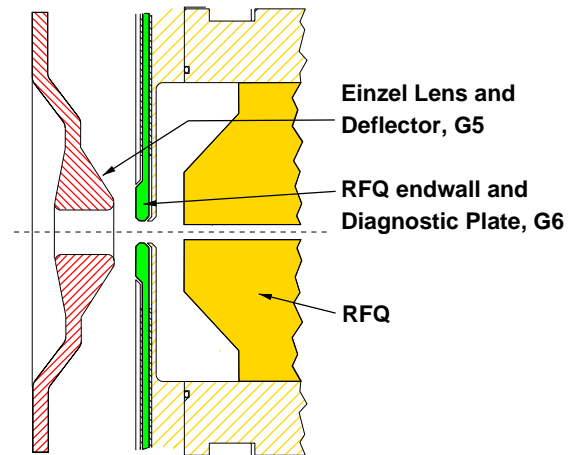

Figure 9: Deflecting Electrode, Diagnostic Plate

The fully operational version of the ion source, LEBT and chopper are currently being manufactured and will be tested by the end of Summer 1999.

## 6 ACKNOWLEDGMENTS

The authors acknowledge the pioneering SNS leadership by Bill Appleton of ORNL, the LBNL SNS leadership team of Rick Gough and Roderich Keller, and the superb development of the SNS ion source by Matthaues Leitner and Ka-Ngo Leung.

## 7 REFERENCES

- [1] R. Keller et al., "The SNS Front-End Systems", Int. Topical Meeting AccApp 98, Nuclear Applications of Accelerator Technology, Gatlinburg, 1998
- [2] John Staples, Daniel Cheng, Martin Fong, James Greer, Matthew Hoff, Roderick Keller, Kurt Kennedy, Matthaues Leitner, Robert MacGill, Daryl Oshatz, Alessandro Ratti, Justin Remais, Steve Virostek, "The SNS Front End Accelerator Systems", 1998 Linac Conference Proceedings, Chicago
- [3] DEI, Inc., Fort Collins, Colo. ([www.dirnrg.com](http://www.dirnrg.com))
- [4] D. W. Cheng et al., "Design of the Prototype Low Energy Beam Transport Line for the Spallation Neutron Source", Paper WEA31, 1999 Particle Accelerator Conference, New York
- [5] M. A. Leitner et al., "High-Current High-Duty-Factor Experiments with the RF-Driven H<sup>-</sup> Ion Source for the Spallation Neutron Source", Paper WEA13, 1999 Particle Accelerator Conference, New York
- [6] S. K. Mukherjee et al., "Mechanical Design of the Prototype H<sup>-</sup> Ion Source for the Spallation Neutron Source", Paper WEA14, 1999 Particle Accelerator Conference, New York
- [7] Private Communication, Matthaues Leitner, LBNL.