

MAGNETIC FIELD SHIMMING, MEASUREMENT AND CONTROL FOR THE BNL MUON (G-2) EXPERIMENT

S. I. Redin*, Yale University, New Haven, CT
for the (g-2) collaboration

Abstract

An ultraprecise superferric magnet, 14 m in diameter, was built for the muon (g-2) experiment currently in progress at Brookhaven National Laboratory. The principal quantities to measure in the experiment are the frequency of (g-2) oscillations and the average magnetic field, which imply stringent requirements on the homogeneity of the magnetic field as well as on the precision of its measurement and control system. This paper describes (g-2) magnet, shimming technics used to improve it and advanced NMR and Hall probes systems to measure and monitor magnetic field.

1 INTRODUCTION

Precision measurement of muon $a_\mu = \frac{1}{2}$ (g-2) value probes short-distance structure of the theory and hence provides stringent test of the Standard Model or, alternatively, search for New Physics beyond. Previous measurement of a_μ [1] confirms theoretically predicted contributions from QED and strong interactions with experimental precision of 7.2 ppm (parts per million). The goal of current BNL muon (g-2) experiment [2] is to lower experimental error to 0.35 ppm, which would allow us to see also weak interactions contribution at the level of 3-4 sigma.

In the muon (g-2) experiment we measure ω_a , the spin precession frequency relative to the momentum vector cyclotron precession for a muon in a uniform magnetic field. Muon a_μ value is evaluated from relation $\omega_a = a_\mu \frac{eB}{mc}$ and hence two quantities, muon (g-2) precession frequency ω_a and magnetic field B, must be measured in this experiment precisely.

Frequency ω_a is measured from time distribution of decay electrons registered by detector stations [3] and its knowledge is principally limited by statistical error of the fit. Magnetic field is measured and controlled by the system of NMR probes. It is designed to provide accuracy and stability of the field (averaged over muon distribution) at the 0.1 ppm level. To achieved this goal, magnetic field across the muon storage region should be shimmed to ~ 1 ppm level of homogeneity.

Magnetic field shimming, measurement and control with advanced NMR system is the main part of this presentation. A number of measurements of the magnetic field were also done with Hall probes. These include measurement of the

radial component of the field in the storage ring and measurement of highly nonuniform magnetic fields near the beam injection point and in the region of straw chambers used for decay electron tracking.

2 SHIMMING OF THE MAGNET

The BNL (g-2) magnet provides a magnetic field of about 1.45 Tesla over the muon storage region, which is of toroidal shape with the radius of the central orbit being 711.2 cm (280 inches) and cross sectional diameter being 9 cm. The cross section of the muon storage ring is shown in Fig. 1. The magnet has a C-shape to allow decay electrons to be observed inside the ring. The field in the storage region is determined dominantly by the iron, i.e. its geometry, construction tolerances, temperature control, etc. The air gap between the pole pieces and the yoke serves to decouple the magnetic field in the storage region from that in the yoke.

The magnet is excited by four ring-shaped supercon-

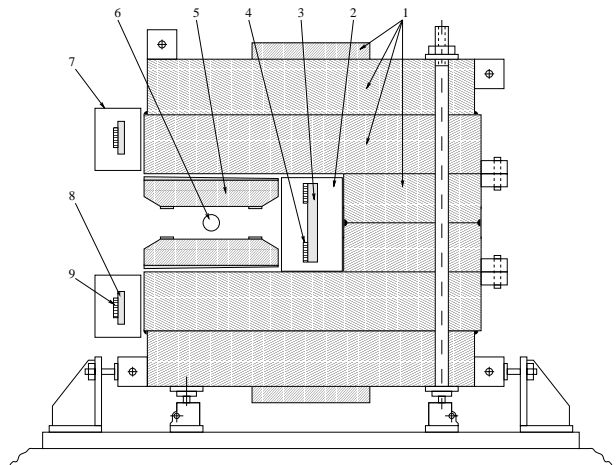

Figure 1: Muon storage ring. 1 – yoke plates, 2 – outer cryostat, 3 – outer mandrel, 4 – outer lower coil, 5 – pole, 6 – muon storage region, 7 – inner upper cryostat, 8 – inner lower mandrel, 9 – inner lower coil.

ducting coils. That provides thermal stability, low power consumption, low resistance R and hence use of a low voltage well regulated (to 0.3%) power supply, high L/R and hence low ripple currents, thermal independence of the coils and the iron.

Magnetic field measured at the first powering of the mag-

* Email: redin@bnl.gov

net in 1996 varied peak-to-peak by up to 1400 ppm (0.14%) in different azimuthal locations in the ring and up to 300 ppm across the muon storage region. Several techniques, shown in Fig. 2, were used to shim the magnet to acceptable level of homogeneity of magnetic field.

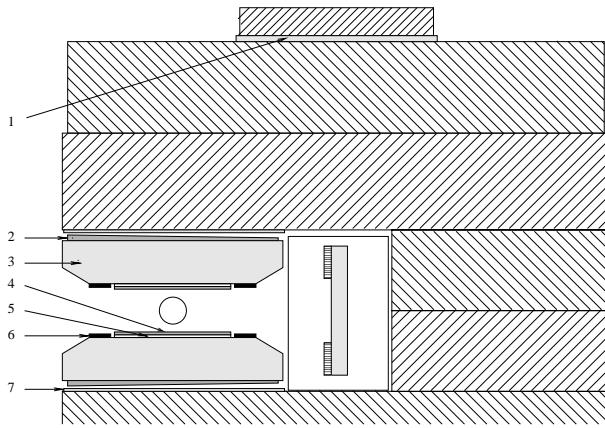

Figure 2: Shimming techniques: 1 – aluminum or iron shims between top and/or bottom iron plate and the rest of the yoke; 2 – iron wedges; 3 – tilting of poles; 4 – aluminum/iron sandwiches; 5 – surface correction coils; 6 – Rose (edge) shims; 7 – dipole correction coils

We started shimming by leveling the pole pieces to eliminate steps between adjacent poles to 0.0005 inch or less. We also adjusted the poles at certain small angle to the horizontal plane such that both top and bottom poles would be horizontal in the powered state.

Aluminum or iron shims between top plate and the rest of the yoke were used to reduce broad azimuthal variations of the field from 1400 ppm to ~ 300 ppm. For relatively short variation, the iron wedges between poles and yoke were moved radially in- or outward.

For correction of the field distribution across the muon storage region, it was extremely fruitful to use Rose (or edge) shims. These are iron strips 5 cm wide on the edges of the poles surfaces. They are 10° long in azimuth, their thickness can be machined to correct the field. Because the Rose shims are so close to the muon storage region, they are a very powerful tool for both wide and local corrections. Shimming with the Rose shims was done in several steps. First, we measured shimming effect of all four shims by taking one 10° section of them out or machine off ~ 1 mm of their thickness between two field measurements. Then we calculated the optimal thicknesses and machine Rose shims for one half of the ring (with some margin). Necessary corrections were applied and all of the Rose shims were machined to the optimal value, uniformly all over the ring. This allowed us to lower pole-by-pole variations of the field across the muon storage region (averaged azimuthally over the ring) to ~ 25 ppm level, see Fig. 3a.

Number of further improvements were made after the

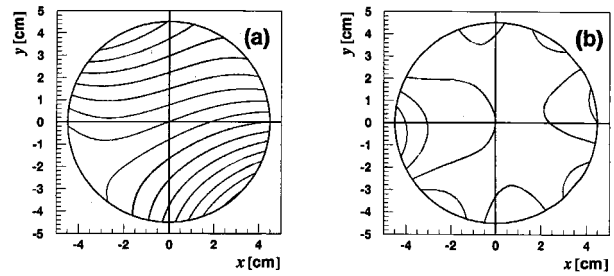

Figure 3: Magnetic field distribution across the muon storage region for 1997 (a) and 1998 (b) runs. The interval between the contours of equal field strength is 2 ppm.

1997 run. The iron yoke was thermally insulated (wrapped) for better temperature stability of the magnetic field. Rose shims were machined individually to reduce large pole-by-pole variations. Other shimming techniques applied before 1998 run were aluminum/iron strips sandwiches to correct local field variations, mostly at boundaries of adjacent pole pieces, and current in the surface correction coils, which are the strips on the printed circuit boards connected together to form loops azimuthally all over the ring. Surface correction coils can be used to correct virtually any set of multipoles. Fig. 3b shows contour plot distribution of magnetic field during the 1998 run, when all techniques, including the surface correction coils, were applied. The peak-to-peak variations were lowered to 5 ppm level.

3 MAGNETIC FIELD MEASUREMENT AND CONTROL WITH NMR PROBES

To measure and control the magnetic field with 0.1 ppm relative accuracy, a pulsed NMR system has been developed [4]. 25 NMR probes were mounted on a movable platform (shimming trolley) and used for the magnet shimming. 17 NMR probes were mounted on a beam tube trolley [5] and used for the mapping the magnetic field during the data taking runs.

The beam tube trolley is a vacuum-tight vessel with cylindrical shape and a length of 0.5 m, curved with the same radius as the storage ring. The trolley drive mechanism pulls the trolley along the ring with an electrical cable. The same cable is used for communication between the trolley and computer in the control room. The trolley rides on rails which help to form the desired electrical quadrupole field. During data taking the trolley is parked in its garage, located radially inward from the muon storage region. The trolley garage mechanism can move a complete 50 cm section of the rails with trolley on it radially outward (inward) at the beginning (end) of magnetic field measurements. Both trolley drive and trolley garage are parts of the muon vacuum chamber, so field measurement with the beam tube trolley can be done without breaking the vacuum.

During the run the measurements with the beam tube trolley were taken every 24 to 72 hours. Each field map

consists of about 6000 readings for each of the 17 NMR probes. Between these measurements the drift of magnetic field was monitored by the 366 fixed NMR probes embedded in the walls of the vacuum chamber in 72 azimuthal locations.

Fixed probes are calibrated by beam tube trolley probes during each field mapping. At the end of the run the 17 trolley NMR probes were calibrated against a single calibration probe [4]. It was, in turn, calibrated with a standard NMR probe [6], which was constructed to measure the NMR frequency of protons in a spherical sample of pure water with a systematic uncertainty of 0.034 ppm.

4 MAGNETIC FIELD MEASUREMENT WITH HALL PROBES

A number of field measurements [7] were done with Hall probes in regions with inhomogeneous magnetic field or for determination of the direction of the field, i.e. when NMR probes can not be used. The most important was measurement of the radial component of magnetic field, which in this experiment must be kept below 50 ppm (averaged over the ring). Our measurement achieved an accuracy of 10 ppm, which was adequate for shimming and control of the radial field.

The Hall probes device, built for this purpose, contains two Hall probes BH-206 installed on the $Z - \Theta$ plane and the electrolytic tilt sensor RG33A along the R axis, on the aluminum support as shown in Fig. 4. The support itself is mounted on the system of platforms in such a way, that it can be tilted (adjusted) within $\pm 0.5^\circ$ from horizontal in $Z - R$ plane and rotated around the vertical Z axis by 180° .

To measure angle between magnetic field and the R

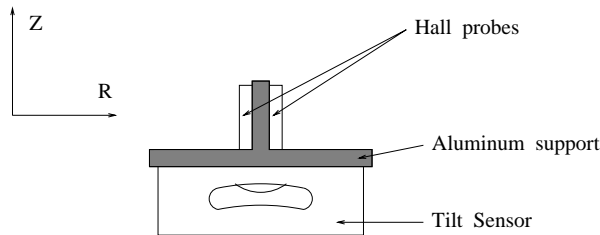

Figure 4: Hall probe device for the radial magnetic field measurements

axis, we first set the tilt of the aluminum support at some small arbitrary angle δ (readout of the tilt sensor) and record the output voltage from the Hall probe V . Then we make 180° rotation, adjust the angle of the support to the same angle δ and take another Hall probe voltage, V' . The angle α between the magnetic field and the vertical axis is given by

$$\alpha = \frac{1}{2} \frac{V - V'}{V(1.45 T)},$$

where $V(1.45 T)$ is a Hall probes output for magnetic field of 1.45 T.

The formula above is insensitive to the following sources of systematic errors: (1) the axis of the 180° rotation is not exactly vertical in $Z - R$ plane, (2) the Hall probes output has offset, (3) the electrolytic tilt sensor output has offset, (4) the axis of the electrolytic tilt sensor is not exactly orthogonal to the plane of the Hall probes, (5) temperature change over time larger than one measurement cycle (before and after flip), which is about 5 minutes. Also note that the systematic error due to not exactly 180° rotation is of second order.

A potentially important systematic error is the planar Hall effect [8]. To eliminate this error, we use two Hall probes with parallel planes, but with orthogonal directions of the Hall currents, in the vertical and horizontal (azimuthal) direction, respectively. After averaging these two Hall probes measurements, the net result will not be affected by this source of systematic errors.

Another important measurement done with Hall probes was the measurement of magnetic field in the region of the traceback system which occupies the radial region from $R = 680$ cm to 705 cm and the vertical region from $Z = -10$ cm to +10 cm, where the magnetic field varies from 1.45 T to ~ 0.2 T. Both vertical and radial components of the field are needed for reconstruction of electron tracks. The azimuthal component of the field is assumed to be zero from symmetry.

The apparatus used for magnetic field measurements in the traceback region consists of two Hall probes mounted on a system of two translation stages which in turn are mounted on the rigid aluminum support and the whole assembly is bolted to the top and bottom poles. The Hall probes were oriented so that one of them measured the vertical component of the field and the other measured the radial component. The translation stages provided radial and vertical motion of the probes. Measurements and calculations are in agreement at the 10^{-3} level, which is sufficient accuracy for the electron track reconstruction.

Magnetic field maps taken by the NMR beam tube trolley have missing points near the beam injection point, where field is highly inhomogeneous. Measurement of radial and azimuthal components of the field with Hall probes improved significantly the model used to describe field distribution in this region.

5 REFERENCES

- [1] J. Bailey et al., Nucl. Phys. B150, 1 (1979)
- [2] Design Report of BNL experiment E821, 1995
- [3] S. Sedykh et al., Proc. of 7th Int. Conf. on Calorimetry in High-Energy Physucs (CALOR 97), Tucson, AZ, 1997
- [4] P. Prigl et al., Nucl. Instr. Meth. A374, 118 (1996)
- [5] A. Grossmann, Ph.D. thesis, University of Heidelberg, 1998
- [6] X. Fei et al., Nucl. Instr. Meth. A394, 349 (1997)
- [7] S. I. Redin, Ph.D. thesis, Yale University, 1999
- [8] B. Turk, Nucl. Instr. Meth. 95, 205 (1971)