

ADVANCED BUCK CONVERTER POWER SUPPLY “ABCPS” FOR APT*

E. Bowles, T. Overett, T. Smith, and R. Street[#]
 General Atomics, San Diego, CA 92186-5608 USA

Abstract

To meet the klystron power supply requirements for the Accelerator for the Production of Tritium (APT), a DC power distribution system with a modern DC-DC switching power supply is proposed as one of the options. One power supply is required for each of the approximately 250 continuous wave klystron RF power sources. As the power supplies are one of the largest cost elements in the accelerator, it is desirable to utilize the most economical design. This proposed advanced buck converter high voltage power supply (ABCPS) does not require large transformers to step-up the output voltage and is potentially the lowest cost power supply approach. The power supply must meet the APT requirements for output performance, fault protection for the klystron, high efficiency, high reliability, good maintainability, and be readily manufacturable. A full-scale prototype power supply is being designed and fabricated. The progress of the prototype design, performance validation, and testing follows.

1 INTRODUCTION

The proposed 1700 MeV APT proton accelerator design would utilize three standard 350 megahertz (MHz) klystron RF sources to drive the RF quadrupole. There would be two hundred and forty one 700 MHz klystron RF sources to power the normal temperature low-energy linac and the super-conducting radio frequency cavities in the high energy linac. One high voltage power supply (HVPS) is required for each of the 244-klystron RF power sources. Two megawatt DC power supplies rated for 95 kilovolts (kV) at 21 amperes (A) DC are planned throughout for commonality.

2 ABCPS ADVANTAGE

The DC-DC switch-mode ABCPS is basically a transformer-less power supply design and no large magnetic cores are used. Removing the expensive high voltage step-up rectifier transformer normally present in other designs produces a lower cost approach to satisfy all APT plant requirements. The APT utility distribution system becomes a common DC distribution bus to feed the ABCPS (Figure 1). This design combines the HVPS isolation and rectification, with the utility distribution and eliminates one or more levels of voltage transformation.

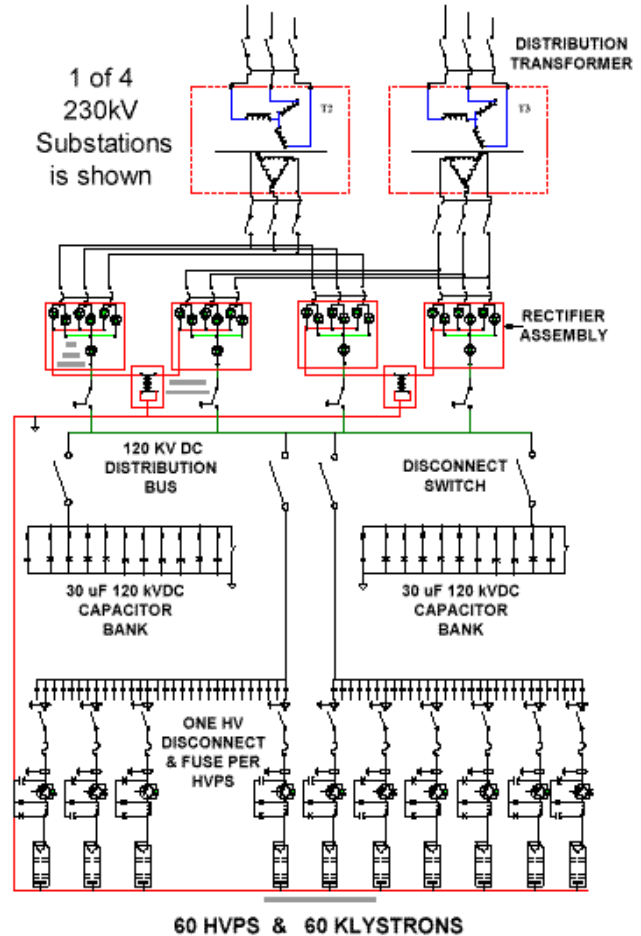

Figure 1: ABCPS DC distribution system for APT

The ABCPS buck-regulator topology is potentially the most efficient because the converter is basically a low loss IGBT switch. A circuit schematic of a single ABCPS is shown in Fig. 2. The raw HVDC input is switched at approximately 18 kilohertz by the HV IGBT switch and charges the output capacitor through a switching inductor. A freewheeling diode (FWD) transfers the inductor energy into the output capacitor (C1) during the IGBT switch off time. The circuit operates in the discontinuous current mode. Almost all the switching circuit energy and the IGBT snubber circuit energy are recovered.

An independent reliability, availability, maintainability, and inspectability (RAMI) analysis has estimated a MTBF of 80,000 hours. With periodic preventive maintenance

* Work supported by DOE under contract DE-AC04-96AL89607

[#] E-mail: richard.street@gat.com

this can increase to 200,000 hours. The ABCPS high voltage components are modular in design with plug-in circuit cards to produce a highly maintainable system. The majority of the HVPS components are standard off-the-shelf parts. This manufacturing approach reduces cost and procurement lead-time. The entire switch assembly can be bench manufactured without the use of special manufacturing or heavy assembly equipment. This also reduces cost and improves manufacturability. The packaging foot print for this HVPS system is smaller than other power supply designs.

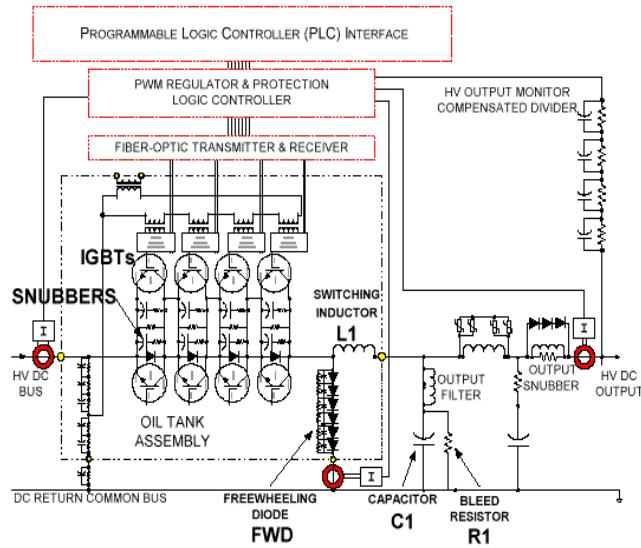

Figure 2: ABCPS schematic

3 ABCPS DESIGN

The topology of this switching power supply is a DC to DC buck converter, which adjusts and regulates the applied voltage to one klystron. There are three major subassemblies in the HVPS enclosure. The first section is a control system that includes a pulse width modulated (PWM) voltage regulator and overload protection circuit card, eight 12-channel fiber-optic gate drive transmitter-receiver circuit cards, and a programmable logic controller (PLC) interface.

The second section contains the high voltage IGBT switch assembly, freewheeling diodes (FWD), switching inductor (L1), and IGBT gate drive power isolation circuitry (Figure 3). All these components are subject to the high frequency chopping waveforms and peak voltage stress. To satisfy thermal cooling needs for continuous operation and assist long term reliability these components are installed in an oil tank filled with Dow Corning[®]™ silicone fluid 561[™]. The oil tank has two oil-to-water heat exchangers to transfer the 10 kilowatts of heat dissipation at full load into the APT plant cooling system. All subassembly validation testing was performed in air. The IGBT and FWD circuit cards are plug-in cards and are quickly accessed through a service cover on top of the oil

tank. There are 24 IGBT modules and 6 FWD modules (Figures 4 & 5) in the full scale HVPS.

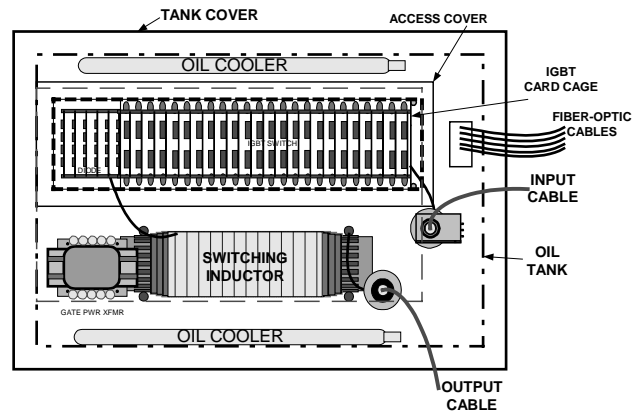

Figure 3: IGBT switch oil tank assembly

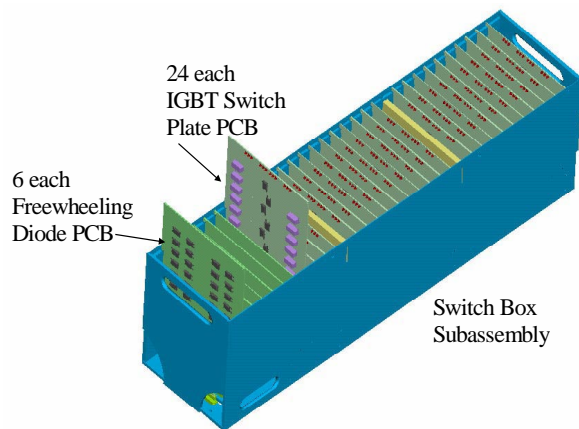

Figure 4: IGBT switch card cage assembly

There are 48 fiber-optic IGBT gate up links, and 48 fiber-optic IGBT data down links. Four fiber-optic cables are needed per IGBT module (Figure 5). The fiber-optic cables provide high voltage signal isolation and connect directly between the IGBT switch modules and transmitter-receiver circuit cards. The fiber-optic cables are color coded for ease of assembly.

The third section is the output ripple filter and fault energy snubber and current bleed resistors. The ripple filter is tuned for optimum ripple reduction while the filter capacitor size is kept to a minimum. All the HVPS inductors are single layer wound air-core coils. Computer PSpice[®]™ analysis indicates less than 100 volts peak-to-peak output ripple at full load.

The output snubber is designed to limit instantaneous fault energy from being deposited into the klystron load during operation when the klystron arcs internally. Analysis of the output snubber indicates there will be less than 10 joules deposited into the klystron during a tube fault. Once the fault is detected, the IGBT switch can

operate in less than one microsecond to protect the klystron. The high speed IGBT switch will provide fast voltage regulation and control. Individual primary high voltage fast acting fuses will be used for back-up power supply and klystron load protection.

volts per board. Each board has been tested to a maximum voltage level of 7,000 volts.

4 TESTING AND DESIGN VALIDATIONS

All subassembly testing to date has been in air. Single IGBT module testing at full voltage, full current, and full thermal power were conducted with forced air-cooling. The IGBT module switch design has proved it is capable of handling more than 105 kilowatts. So far four modules have been operated in series. These were connected in a high power pulse mode circuit. They were tested above their design ratings to 7 kilovolts and 50 amperes. All IGBTs uniformly switched on and off. Their turn on time is approximately 150 nanoseconds. The minimum pulse width capability of this IGBT switch module is between 1 and 2 microseconds. To date no problems have been encountered that would require a change in the design. Each circuit board has been tested and the results validate the design goals. The final construction of the full-scale prototype power supply is in progress.

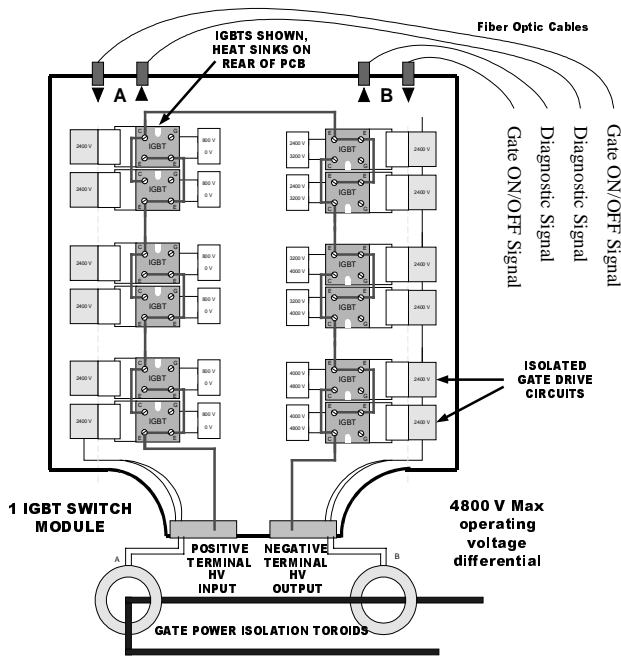

Figure 5: IGBT switch plug-in module

The current bleed resistor (R1, Figure 2) value is directly related to the minimum no load output voltage since it is the lower end resistor in a resistive voltage divider. The upper end resistor being the leakage resistance of the non-conducting IGBT switch.

The 120-kilovolt IGBT switch assembly is a string of 144 series connected IGBTs in parallel with another identical string of 144 IGBTs to provide redundancy. Each IGBT string has independent gate drive power and signals. Because uniform voltage sharing is critical under all operating conditions, each IGBT has forced voltage sharing and transient snubbing. Twelve IGBTs along with their heat sinks, and gate circuits are contained on one plug-in circuit board. Each IGBT module is designed for normal operation at 4,800 volts. The 1,200-volt rated IGBTs operate at 800 volts. Six in series provides 4,800

5 APT HVPS OUTPUT CHARACTERISTICS

- Output DC voltage: Continuously variable- 4 to - 95 kV
- Output DC polarity: Negative with respect to ground
- Output voltage set-point accuracy: ± 400 V
- Output voltage rate of increase: 10 kV / second max.
- Output current rate of increase: 200 A / second max.
- Regulation range: 10 – 95 kV
- Regulation requirements (line & load): ± 400 V max.
- Ripple @ any 60 Hz harmonic: 800 V peak-to-peak max.
- Total ripple (all causes): 1100 V peak-to-peak max.
- Voltage stability: $\pm 0.4\%$ max.
- Output DC current: 0 - 21 A
- Load fault protection: 40 joules max.

6 REFERENCES

- [1] Linac98 conference paper No.LA-UR-98-3613 "Advanced Buck Converter Power Supply "ABCPS" for APT", by R. Street, T. Overett, Ed Bowles
- [2] Linac98 conference paper No.LA-UR-98-3518 "Overview of the APT RF Power Distribution System", by M. McCarthy , T. Overett, G. Spalek, J. Tooker