



**THE INSULATION VACUUM BARRIER FOR
THE LARGE HADRON COLLIDER (LHC) MAGNET CRYOSTATS**

M Castoldi, F. Dolizy*, V. Parma, B. Skoczen, Ph. Trilhe

Abstract

The sectorisation of the insulation vacuum of the LHC magnet cryostats, housing the superconducting magnets, which operate in a 1.9 K superfluid helium bath, is achieved by means of vacuum barriers. Each vacuum barrier is a leak-tight austenitic stainless steel thin-wall structure, mainly composed of large diameter (between 0.6 m and 0.9 m) bellows and concentric corrugated cylinders. It is mounted in the Short Straight Section (SSS) [1], between the magnet helium enclosure and the vacuum vessel. This paper presents the design of the vacuum barrier, concentrating mostly on its expected thermal performance, to fulfil the tight LHC heat in-leak budgets. Pressure and leak test results, confirming the mechanical design of two prototypes manufactured in industry, and the preparation of one of these vacuum barriers for cryogenic testing in an SSS prototype, are also mentioned.

EP, EST, LHC Divisions

*SGS-QUALITEST, BP 49, Site de Prévessin, 01631 CERN

Presented at the Eighteenth International Cryogenic Engineering Conference (ICEC 18)
21-25 February 2000, Bombay Mumbai, India

Administrative Secretariat
LHC Division
CERN
CH - 1211 Geneva 23
Switzerland

Geneva, 26 July 2000

The Insulation Vacuum Barrier for the Large Hadron Collider (LHC) Magnet Cryostats

Matteo Castoldi, Frédéric Dolizy*, Vittorio Parma, Blazej Skoczen, Philippe Trilhe

LHC Division, CERN, 1211 Geneva 23, Switzerland

*SGS-QUALITEST, BP 49, Site de Prévessin, 01631 CERN

The sectorisation of the insulation vacuum of the LHC magnet cryostats, housing the superconducting magnets, which operate in a 1.9 K superfluid helium bath, is achieved by means of vacuum barriers. Each vacuum barrier is a leak-tight austenitic stainless steel thin-wall structure, mainly composed of large diameter (between 0.6 m and 0.9 m) bellows and concentric corrugated cylinders. It is mounted in the Short Straight Section (SSS) [1], between the magnet helium enclosure and the vacuum vessel.

This paper presents the design of the vacuum barrier, concentrating mostly on its expected thermal performance, to fulfil the tight LHC heat in-leak budgets. Pressure and leak test results, confirming the mechanical design of two prototypes manufactured in industry, and the preparation of one of these vacuum barriers for cryogenic testing in an SSS prototype, are also mentioned.

1 INTRODUCTION

The superconducting magnets of the LHC machine will be housed in cryostats having an insulation vacuum of 10^{-4} Pa. These cryostats, with vacuum vessels of 914 mm outer diameter, will cover about 22 km of the circumference of the LHC machine, divided into eight cryogenic and vacuum sectors. A finer longitudinal sectorisation (some 200 m long) of the insulation vacuum compartments, by the insertion of vacuum barriers, is required to achieve the following functions: it allows a piece-wise installation and commissioning of the vacuum systems, an easier localisation of leaks and the containment of an eventual accidental vacuum degradation. Additionally, it eases local intervention for machine maintenance. Each vacuum compartment requires a leak-tightness of 10^{-8} Pa m³ s⁻¹, with respect to the adjacent ones and to the atmosphere.

Around 100 vacuum barriers are required to achieve this vacuum sectorisation without interrupting the continuity, in a sector, of the LHC beam pipes and the electrical and cryogenic circuits. When separating a vacuum compartment from atmospheric pressure (machine installation or maintenance), loads of about 64 kN, due to a pressure difference of 0.1 MPa, must be supported by the vacuum barrier. Higher exceptional loads of about 95 kN may occur in case of an accidental degradation of vacuum during machine operation, resulting from a pressure rise up to 0.15 MPa before over-pressure valves open.

The unavoidable heat in-leaks introduced by the vacuum barrier to the 1.9 K magnet helium enclosure are limited for the stringent thermal budgets imposed by the machine cryogenic system. Indicative values are: 0.5 W at 1.9 K, 0.05 W at 4.5-10 K and 10 W at 50-65 K.

The conflict between mechanical requirements and the achievement of the specified thermal budgets has led to a trade-off design of the LHC vacuum barriers.

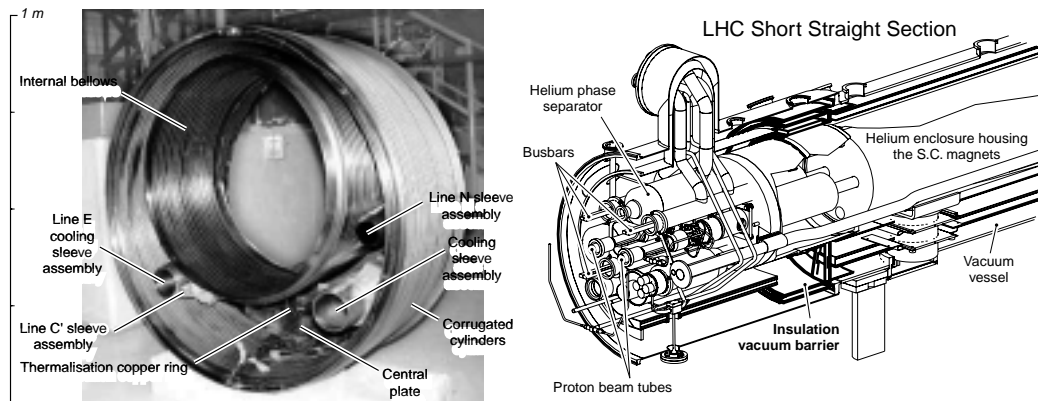

Figure 1 LHC Insulation Vacuum Barrier prototype and its integration in the LHC Short Straight Section

2 THE INSULATION VACUUM BARRIER

A vacuum barrier (Figure 1) is essentially an austenitic stainless steel (AISI 316L) leak-tight welded structure, composed of two concentric corrugated cylinders, of about 900 mm diameter and 1.3 mm thick and one internal bellows, of about 600 mm diameter and 0.4 mm thick, linked together by a 6 mm thick central plate. The vacuum barriers are integrated within the LHC SSS, the cryostat units housing the main quadrupole magnets and incorporating the cryogenic loop control equipment. The internal bellows of the vacuum barrier is welded onto the magnet helium enclosure operating at 1.9 K, whereas the outermost corrugated cylinder is welded on the cryostat vacuum vessel, which is at room temperature (293 K). The vacuum barrier must provide only feed-throughs for the cooling lines running through the cryostats of a cryogenic sector. These are obtained by tubular sleeve assemblies incorporating a bellows to allow relative movements due to thermal contraction and to reduce conduction heat in-leaks.

A high-purity copper ring, brazed to the central plate and thermally linked to the cooling line E (operating at 50-65 K) by two low-thermal-impedance straps, thermalises the central plate, thus reducing the residual heat in-leaks to 1.9 K. Furthermore, cylindrical multi-layer insulation (MLI) blankets (not shown in Figure 1) using double aluminised Mylar™, interleaved by an insulating spacer, further reduce radiation heat in-leaks. The number of blankets and number of layers per blanket were optimised to keep heat in-leaks within the budgets.

2.1 Thermo-mechanical Design

In the design of the vacuum barrier, the mechanical functions of the internal bellows and of the two concentric corrugated cylinders are de-coupled. The inner bellows has been optimised with the aim of minimising its transverse and longitudinal stiffness for a design pressure of 0.15 MPa acting on either side of the barrier. This confers a large flexibility to the vacuum barrier permitting the thermal contraction movements of the magnet helium enclosure within the cryostat. As a result of this low stiffness, the internal bellows only takes a minor part of the pressure loads. Conversely, the corrugated shells have been designed to withstand the total pressure loads while limiting the displacements of the central plate to avoid longitudinal interference with other components. In this case, a high longitudinal stiffness has been specified.

A long thermal path between the vacuum vessel and the helium enclosure is desirable to limit solid conduction heat in-leaks. However, the available space in the SSS constrained the overall dimensions of the vacuum barrier. The longitudinal space imposed a maximum length of the bellows and corrugations of around 300 mm, whereas the transverse space available between magnet helium enclosure and vacuum vessel limited the number of bellows and corrugated cylinders which could be nested. The only design freedom to increase the thermal path remained in the choice of the shape, depth and thickness of the convolutions. The design of the bellows and corrugated cylinders was made, for a number of industrially available convolution types, by using a mechanical optimisation algorithm [2,3,4]. The design objective of this method is to achieve the lateral or longitudinal stiffness, while fulfilling a set of constraints, which include strength and fatigue life, stability (column buckling and in-plane squirm), and available space. This design process, together with a finer thermal analysis, explained in the following, allowed an iterative process leading to the choice of the bellows and corrugated cylinders of the vacuum barrier.

2.2 Thermal Performance

As heat in-leaks from the vacuum vessel to the magnet helium enclosure are primarily dominated by solid conduction through the vacuum barrier wall, this was the only parameter included, in a first instance, in the thermo-mechanical optimisation of the bellows and corrugated cylinders. However, the non-negligible radiation heat contribution from the vacuum vessel, through the vacuum barrier, to the magnet helium enclosure, and the protective effect of the MLI, needed to be included in a finer thermal analysis. A heat transfer computation model, based on a simplified pseudo-analytical formulation, was therefore developed, with the aim of estimating the heat in-leaks and temperature mapping of the vacuum barrier [5].

This model includes solid conduction and radiation according to the formulae:

$$Q_c = \frac{A \cdot \lambda}{L} \cdot (T_1 - T_2) \quad r := \frac{\sigma \cdot [(T_1)^4 - (T_2)^4]}{\frac{1 - \epsilon_1}{S_1 \cdot \epsilon_1} + \frac{1}{S_1 \cdot F_{1-2}} + \frac{1 - \epsilon_2}{S_2 \cdot \epsilon_2}}$$

where A and λ are the average cross-section and conductivity between two points, L is their distance, σ is the Stefan-Boltzman constant, S_1 and S_2 are the radiation surfaces, ϵ_1 and ϵ_2 their emissivities and F is a view factor.

The combination of radiation and conduction through the N layers of an MLI blanket is modelled according to the relationship [5,6]:

$$Q_{MLI} = \left[\frac{\beta}{N+1} \cdot (T_1^4 - T_2^4) \right] + \frac{\alpha}{N+1} \cdot \frac{T_1 + T_2}{2} \cdot (T_1 - T_2)$$

where α and β are constants accounting for the average thermal conductivity and emissivity of the insulation system. Residual gas conduction is neglected in the model. For the above phenomena, a generalised thermal impedance R can be defined according to the equation:

$$Q := \frac{T_1 - T_2}{R}$$

By defining a number of intermediate temperature nodes on the vacuum barrier, an equivalent network can be built (Figure 2, right) describing the heat transfer, leading to a system of equations with temperature-dependent impedances. Its solution, through a finite difference method, for a given set of boundary condition temperatures, yields the steady-state heat loads and temperatures at the network nodes. The parameterisation of the geometry of the vacuum barrier (bellows and corrugated cylinders geometry, number of MLI blankets and layers, etc.) allowed the investigation over a wide variety of design solutions and led to the final choice of the MLI protection.

Table 1 and Figure 2 summarise the calculated heat in-leaks and temperature maps for the two extreme operating temperatures of the cooling line E in an LHC cryogenic sector, 50 K (results between brackets) and 65 K. A strong E line temperature dependence can be observed. The heat in-leak requirements are however achieved with good margin at the 1.9 K and 4.5 K, despite some 15 % excess at 50-65 K. Furthermore, it can be noted that the radiation protection of the MLI blankets is essential to keep the heat in-leaks within the budgets. Finally, a maximum power of 12 W needs to be extracted through the thermalisation copper ring and the cooling sleeves. The latter were designed to allow this heat to be extracted with a given maximum temperature drop of 5 K.

	Magnet helium vessel at 1.9 K [W]	E line at 50-65 K [W]	C' line at 4.5 K [W]
Total Heat load	0.424 (0.268)	11.06 (11.60)	0.029 (0.019)
Only conduction	0.384 (0.230)	10.41 (10.78)	0.029 (0.019)
Total Heat load without MLI	1.677 (1.355)	20.50 (21.18)	0.029 (0.019)

Table 1 Calculated heat in-leaks for the Vacuum Barrier, E line at 50 K (and 65 K)

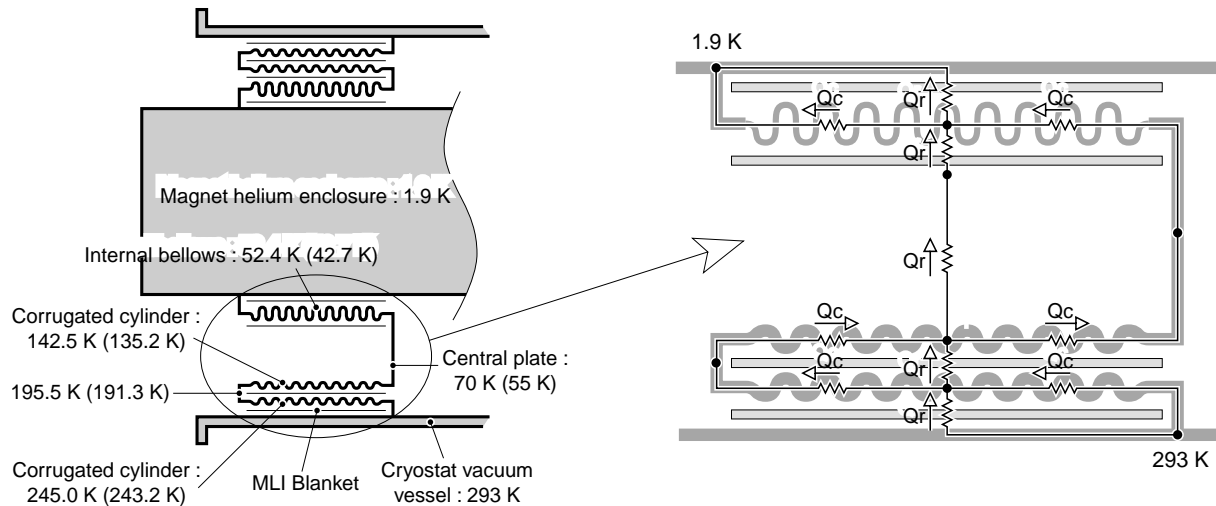

Figure 2 Temperature mapping with E line at 50 K (and 65 K) and partial scheme of the equivalent network

3 PROTOTYPE TESTING

Two prototypes have been manufactured in industry, one of which has been integrated in a prototype SSS which will undergo cryogenic testing. Prior to integration, this vacuum barrier has been separately tested on a dedicated facility allowing pressure and leak testing. The maximum operating pressure of 0.15 MPa was applied on either side of the vacuum barrier while keeping vacuum on the other side. No residual plastic deformation was detected after a number of pressure cycles proving its mechanical strength, also after thermal shocking of the welds with liquid nitrogen. The measured stiffness of the bellows and corrugated cylinders confirmed the specified design values. The global required leak-tightness was verified using helium detection techniques. The thermal performance of the vacuum barrier, which is equipped with temperature sensors, will be assessed during the forthcoming cryogenic tests of the SSS.

4 CONCLUSION

Around 100 vacuum barriers, housed in every fourth SSS of the LHC machine lattice, are required to achieve the sectorisation of the LHC insulation vacuum. These, consisting of a stainless-steel welded structure with corrugated cylinders and bellows, have been designed to satisfy to strength and deformation requirements under pressure loads while fulfilling heat in-leak budgets. A thermo-mechanical optimisation method was used to explore a range of possible bellows and corrugated cylinders geometrical solutions. A dedicated thermal calculation model was set-up to estimate the steady-state heat in-leaks from solid conduction, radiation heat and including the protection effect of MLI blankets. The heat in-leak requirements are achieved with good margin at 1.9 K and 4.5 K, but with some 15 % excess at 50-65 K. A confirmation of these results is however needed through the forthcoming cryogenic testing of a prototype vacuum barrier, suitably equipped with temperature sensors and mounted in an SSS.

REFERENCES

1. Cameron, W. et al. The new superfluid helium cryostats for the Short Straight Sections of the CERN Large Hadron Collider (LHC) *Advances in Cryogenic Engineering* (1997) s43-A 411-417
2. Skoczen, B. Effect of Shear deformation and relaxation of support conditions on elastic buckling of pressurised expansion bellows *ASME Journal of Pressure Vessels Technology* (1999) 121 127-132
3. Skoczen, B. Preliminary optimum design of the expansion joints for the LHC dipole-dipole interconnections, LHC Project Note 34 (1996), unpublished
4. EJMA, Standards of the Expansion Joint Manufacturer Association, 7th Edition, Tarrytown, New-York (1998), 10591
5. Castoldi, M. and Parma, V. Thermal analysis of the LHC Insulation Vacuum Barrier in Stainless Steel Material, CERN/LHC-CRI Technical Note 98-11, unpublished
6. Riddone, R. Theoretical modelling and experimental investigation of the thermal performance of the LHC prototype lattice cryostat, Doctoral Thesis work, Politecnico di Torino, (January 1997), 27-28, unpublished