

HIGH RESOLUTION BPM FOR FUTURE COLLIDERS

C. Magne, M. Juillard, M. Lalot, A. Mosnier, B. Phung, DAPNIA/SEA, CEA-Saclay, France
 Y. Lussignol, DAPNIA/SIG, CEA-Saclay, France
 R. Bossart, CERN, Geneva, Switzerland

Abstract

A beam position monitor using a coaxial reentrant RF cavity has been designed and tested. Main advantages are the small size, the high precision, excellent linearity, and the broadband operation. The measured resolution is 10 microns on the low current beam of the TTF linac. The expected resolution is 700 nm for the high current beam of TTF.

1 INTRODUCTION

High resolution beam position monitors (BPM) will be needed for the future linear colliders. Large band-widths will also be important to operate fast feedback systems. We have designed and tested on TTF (Tesla Test Facility) a broadband BPM which can also be operated at liquid helium temperature.

The TTF superconducting linac at DESY is now in operation with a low charge injector delivering bunches at 216 MHz. In the next step an RF gun will provide high charge (8 nC) bunches at the frequency of 1 MHz. The BPM is suited to both operating modes. In the first case the tests have shown a resolution of 8 μm . In the second case a resolution of 0.7 μm is expected.

2 PRINCIPLE OF THE BROADBAND BPM WITH A REENSTRANT CAVITY

A reentrant cavity (fig.1) has a small size and the broad band is well adapted to the measurement of high charge short-bunched beams, such as they will be in future colliders [1]. The beam coupling impedance is advantageously weak. The measurement frequency is chosen well below the monopole (TEM) and dipole (TE₀₁₁) modes of the cavity, and below the cut off frequency f_c of the dipole TE₁₁ mode of the cavity considered as a coaxial transmission line (table 1). The beam excites an "evanescent" TE₀₁₁ mode [2], in proportion of its displacement off axis, damped towards the bottom of the reentrant cavity. The energy is concentrated in the gap where the antennae are located. The higher order modes are damped much more strongly so their contribution is negligible and the linearity of the measurement is ensured.

If $U_1, U_2, U_3,$ and U_4 are the voltages induced on each antenna, U_m the voltage induced by the monopolar mode on each antenna, I the beam current, x and y the beam displacements from the axis, then the transfer impedance is defined by:

$$Z_t = \frac{U_m}{I}$$

and the dipolar constant L is defined by:

$$x = L \frac{U_1 - U_3}{U_1 + U_3} \quad y = L \frac{U_2 - U_4}{U_2 + U_4}$$

Z_t and L are calculated analytically in [2] and the BPM sensitivity is

$$S = 2 \frac{Z_t}{L}$$

3 FABRICATION OF THE CAVITY

The BPM precision at room and cryogenic temperatures (cooling without deformation) relies on the axial symmetry obtained by machining the cavity with a lathe. The beam pipe radius is 78 mm and the gap of the reentrant cavity is 8 mm. A demountable cavity was fabricated (figure 1) and severe tolerances were applied on the radii and the perpendicularity of the assembling surface (2/100). The concentricity of the cavity walls actually measured on the cavity is better than 20 μm .

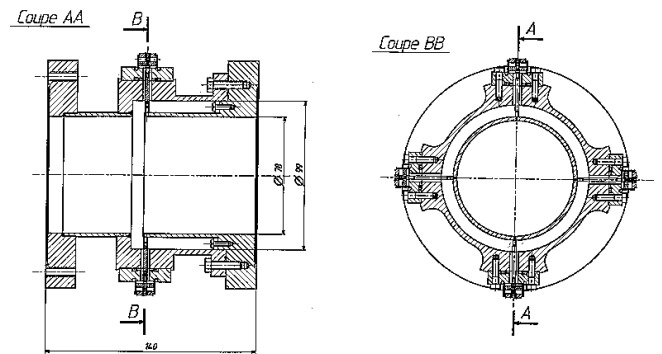

Figure 1: BPM cavity

The feedthrough have a standing wave ratio below 1.02 at 650 MHz. They ensure vacuum tightness between the linac 10^{-11} vacuum and the 2 K helium bath. To achieve broadband operation the cavity is strongly overcoupled by fixing the antenna tips to the inner diameter of the cavity. The external Q factor is about 4.

4 RF MEASUREMENTS OF THE CAVITY ALONE

The transmissions between two opposite antennae have been measured with a network analyser for two positions of the antennae: pulled out or fully pushed. The first

position (resonant mode) is used to spot the precise resonance frequencies and the second one (broadband mode) to visualize the bandwidth really used in the operation mode (figure 2 and table 1).

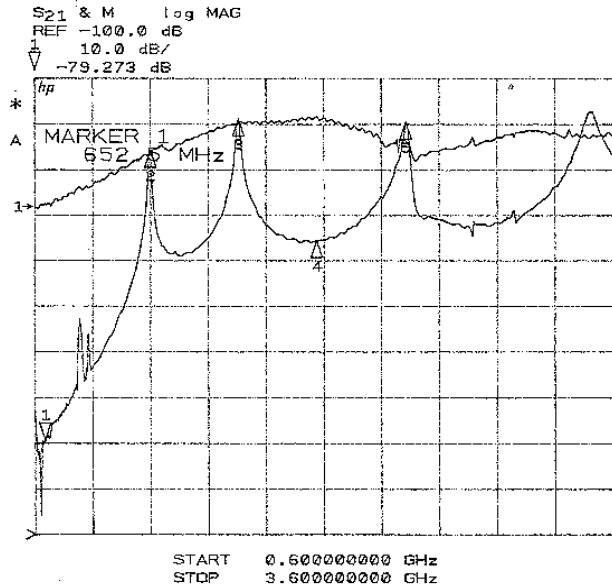

Fig. 2: Cavity transmission, broadband(1) and resonant(2)

5 SIGNAL PROCESSING

A 180° hybrid junction is connected to each pair of opposite antennae, yielding directly the sum and difference RF voltages proportional to the beam current and position. These RF signals are then filtered, amplified, and demodulated with a superheterodyne reception. To achieve a good balance between the 4 ports the hybrid coupler is placed in a box as close as possible to the cavity. And a "perpendicular balance" is done: A reference signal is input through the horizontal antennae while attenuators and phase shifters are adjusted to cancel the vertical power output.

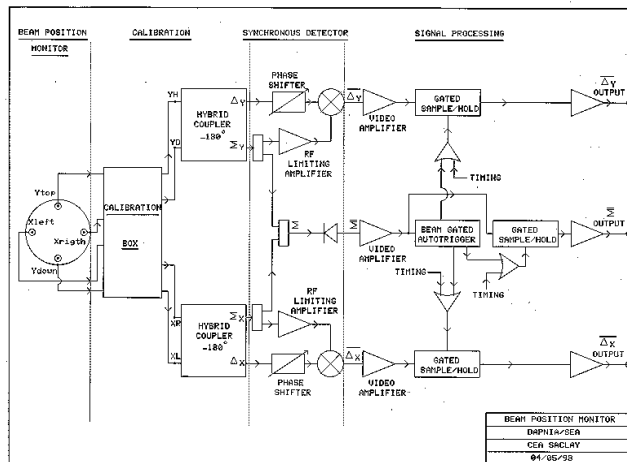

figure 3: BPM electronics

The acquisition board yields analog output for noise measurements and digitized 14 bit output for the control system. The software used is EPICS.

6 CALIBRATION ON A TEST BENCH

A test bench has been assembled to calibrate the BPM without beam, at room temperature. The beam is simulated by a moveable rod. The cw RF power equivalent to the beam current is injected through transition cones as shown on figure 11. The cones have a reflection coefficient of 0.25.

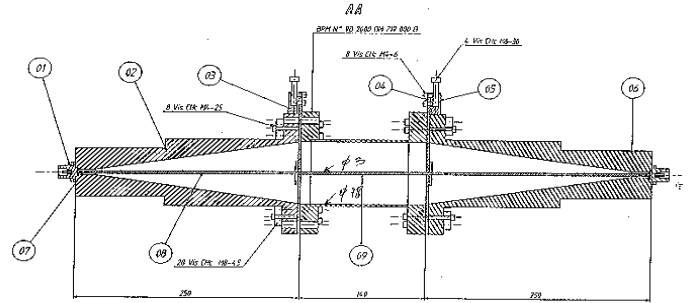

figure 4: Test bench for the BPM cavity and electronics

The characteristics measured with a network analyser are compared with the theoretical values in table 1. The linearity is shown in fig. 5. The noise measured is 20 mV for a 4 V/mm signal, so the resolution is 5 μm.

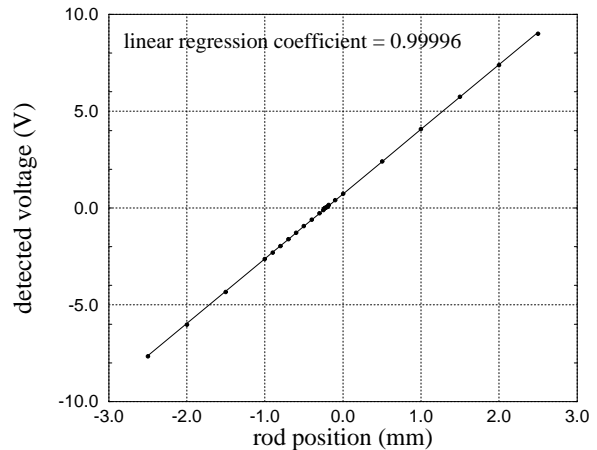

Fig.5: BPM test on bench

The precision after calibration is given in table 2. Micrometric shifters should be used to evaluate the relative precision better.

Table 1 (measurement frequency = 0.650 GHz)

	calculated	measured
f_c (GHz)	1.0	
f_{TEM} (GHz)	1.24	1.20
f_{TE011} (GHz)	1.7	1.658
Z_t (Ω)	6.2	8
L (mm)	37.5	
S (mV/mm/mA)	0.331	0.26

Table 2

absolute precision	0.2mm
relative precision	<50μm

7 MEASUREMENTS WITH THE TTF BEAM

One BPM has been tested inside the capture cavity cryostat at 2 K and the other at room temperature.

a) Absolute precision Δ : The BPM error Δ_{bpm} and the alignment error Δ_{align} give:

$$\Delta = \Delta_{\text{bpm}} + \Delta_{\text{align}} = 0.2 \text{ mm} + 0.1 \text{ mm} = 0.3 \text{ mm}.$$

b) Beam current measurement: The beam current is measured between 0.1 mA and 8 mA. By adding a high gain preamplifier the dark current emitted by the cavity (as low as 100 nA) can also be measured.

c) Resolution: The measured noise is 40 mV when the RF amplifier is 54dB and the video amplifier has a gain of 100. With the 5 V/mm BPM calibration for a beam current of 8 mA this leads to a resolution of 8 μm .

e) Linearity: The x and y beam displacements were measured with an 8 mA, 35 μs , 10 Hz beam while horizontal and vertical steerers were varied. The steerers are 1.513 m upstream. Their linearity is such that $\delta x / I_{\text{steerer}} = 2.188 \text{ mm/A}$ with a precision of .002 mm/A over the range -4V, +4V. (The DC power supplies are stabilised to 10^{-3}).

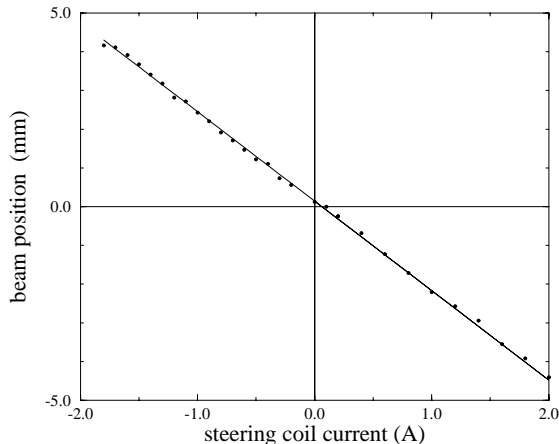

Figure 6: Measurement of the TTF beam position. The linearity in y is observed with a regression coefficient of $R = 0.9996$ (fig. 6). In that example a fluctuation of the beam position is seen with a standard deviation of 150 μm , about 5% of the beam size.

8 EXPECTED RESOLUTION IN THE CASE OF INJECTOR 2

The short bunch signal is filtered at the output of the hybrid coupler. Bessel filters of order 7 have been chosen as they have the less distorted time-domain response and shortest rise time. The 4 MHz bandwidth Bessel filter entirely determines the time response of the electronic chain. The 10 ps bunch can be considered as a Dirac impulse and the input current is: $I_{\text{in}}[\text{A}] = 8 \times 10^{-9} \times \delta(t)$. Calculating the output current from the transfer function of the filter we find an envelope amplitude of $8 \times 10^6 \times I_{\text{in}}$

with a time response width fitting inside the 1 μs bunch separation. A comparison with the current of the injector #1 shows that a factor 12 is gained on the sensitivity. As the noise level will be unchanged (since the same electronics are kept except for a modified acquisition card) the resolution will be: $8 \mu\text{m} / 12 = 700 \text{ nm}$.

9 CONCLUSION

a) Results of the tests (low bunch charge)

The axial symmetry of the RF cavity allowed a high fabrication precision (2/100) and the absolute precision of the BPM was measured on a test bench (0.2 mm).

On the Tesla Test Facility the BPM was tested at 2 K and at 300 K; the beam position is measured in the ranges 0 to 1 mm, and 1 mm to 10 mm; the beam current and the dark current can be measured. The pass-band is 4 MHz due to the RF filter chosen. The acquisition time is 1 μs . The resolution (at low bunch charge) is 8 μm .

b) Plans for injector 2 (high bunch charge: 8 nC)

By modifying slightly the acquisition card (changing the sample-and-hold amplifier) the BPM is presently being adapted to the high charge 1 MHz bunches of the injector #2. The resolution will be 700 nm if nothing else is changed (same RF amplifier, same RF filter).

c) New technical developments

Changing the RF amplifier to a low noise amplifier and broadening the pass-band of the RF filter from 4 MHz to 20 MHz will increase the resolution in the case of high bunch charge beams. A resolution of 100 nm should be obtained at 8 nC bunch charge.

d) New applications

It is possible to use the BPM without the present electronics (4 MHz band-width) and benefit from the real bandwidth of the BPM cavity and hybrid coupler (about 200 MHz) if a degraded resolution (about 100 μm) is accepted. This is presently tested to measure the HOM impedances of the TTF 9-cell superconducting cavities. Resonances due to the HOM are excited by an offset of the beam position and a modulation of the beam current at frequencies from 5 MHz to 100 MHz. The growth of the resonances inside the 35 μs bunch train is observed with an oscilloscope and a spectrum analyser.

Another application is to build a new acquisition board with flash components. In that case the BPM would have a 25ns measurement time and could be inserted in a fast position feedback loop.

10 REFERENCES

- [1] R. Bossart, "High precision beam position monitor using a re-entrant coaxial cavity" Proceedings of LINAC94, KeK, (1994).
- [2] R. Bossart, "Microwave beam position monitor using a re-entrant coaxial cavity," CERN report PS 91-59 (1992).