

Radiation Hard Optical Links for the ATLAS SCT and Pixel Detectors.

D.G.Charlton, J.D.Dowell, R.J.Homer, P.Jovanovic, G.Mahout
H.R.Shaylor, J.A.Wilson

School of Physics and Astronomy, University of Birmingham, Birmingham B15 2TT, UK

R.L.Wastie, A.R.Weidberg

Physics Department, Oxford University, Keble Road, Oxford, OX1 3RH, UK,
t.weidberg@physics.ox.ac.uk

S.Galagedera, M.C.Morrissey, J.K.Troska, D.J.White

CLRC Rutherford Appleton Laboratory, Chilton, Didcot, Oxon, OX11 0QX, UK

A.Rudge

CERN, CH-1211, Geneva 23, Switzerland

I.-M. Gregor

Physics Department, Postfach 10 01 27, Gaußstrasse 20, D-42119 Wuppertal, Germany.

M.L.Chu, S.C.Lee, P.K.Teng

Institute of Physics, Academia Sinica, Tapei, Taiwan 11529.

Abstract

The radiation hard opto-electronic links being developed for the ATLAS Semiconductor Tracker (SCT) and Pixel detectors are described. The results of the radiation tests on all the on-detector components are reviewed. Results of environmental tests of irradiated opto-packages are mentioned. New results on Single Event Upset Studies are presented and the implications for ATLAS operation are discussed

Two versions of the ATLAS SCT style on-detector opto-package are described. The performance of these packages are compared to the ATLAS specifications. These packages have been integrated into the SCT system and extensive system tests have been performed. The experience with the assembly of the first larger scale integration is discussed.

I. INTRODUCTION

Optical links will be used for the readout of the ATLAS SCT and Pixel detectors[1]. The specifications for the links are summarised briefly in section II, The status of the radiation testing of the components and a discussion of the new results on Single Event Upsets is given in section III. The description and performance of two versions of the on-detector opto-packages is given in section IV. Experience with the first attempts to assemble an opto-harness is discussed in section V. Conclusions and outlook are given in section VI.

II. LINKS SPECIFICATIONS

The SCT links transfer digital data from the SCT modules to the off-detector electronics (RODs) at a rate of 40 Mbits/s. Optical links are also used to transfer Timing, Trigger and Control (TTC) data from the RODs to the SCT modules. Biphase mark encoding is used to send the 40 Mbit/s control data for a module on the same fibre as the 40 MHz bunch crossing clock. The architecture illustrated in Figure 1 below, contains

immunity to single point failure to maximise the system robustness[2].

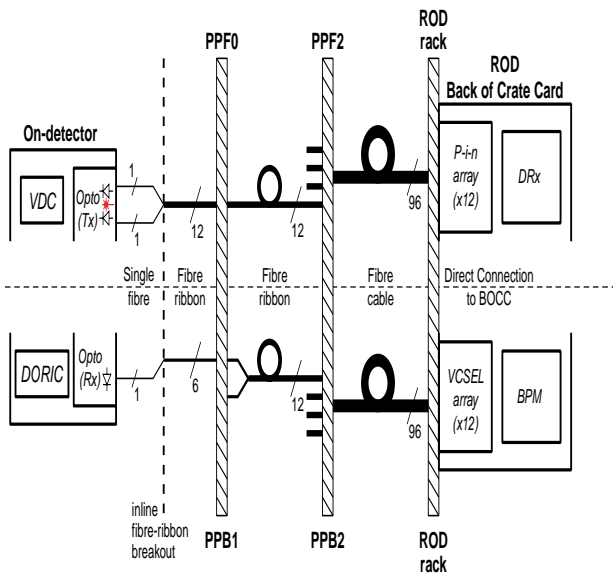

Figure 1 SCT links architecture.

The pixel detector will use a similar architecture but with only one data link per module for the two outer layers.

The radiation hardness requirements[3] are summarised in Table 1 below.

Table 1 Radiation specifications.

Requirement	SCT	Pixels
Ionising dose (kGy)	10^5	$5 \cdot 10^5$
Neutron fluence for Si devices ($1 \text{ MeV } n_{\text{eq}} \text{ cm}^{-2}$)	$2 \cdot 10^{14}$	10^{15}
Neutron fluences for GaAs devices ($1 \text{ MeV } n_{\text{eq}} \text{ cm}^{-2}$)	$1.2 \cdot 10^{15}$	$6.4 \cdot 10^{15}$

III. RADIATION TESTS

Tests have demonstrated the radiation hardness of the PIN diodes up to the Pixel levels[4]. The VCSELs have been demonstrated to be sufficiently radiation hard for the SCT[5] and tests are continuing to evaluate their use in the Pixel detector. The VDC and DORIC4 ASICs used for the SCT system have been fabricated in a non-radiation hard technology but a sufficiently radiation tolerant design has been achieved for the use in the SCT[6]. More radiation hard versions of these ASICs for use in the Pixel detector are being designed in the

radiation hard DMILL CMOS technology. The pure silica core, fluorine spike doped fibre has been demonstrated to be extremely radiation hard[7].

The operation of the links in simulated LHC radiation environments has been studied to determine the sensitivity to Single Event Upsets (SEU). The SEU studies were performed with MIPs from a Sr^{90} source, 14 MeV neutrons and pions and protons in the momentum range 300 to 500 MeV/c. The SEU effects were studied by measuring the Bit Error Rates of the links as a function of the current in the PIN diode, I_{PIN} . The BER was found to decrease rapidly with increasing I_{PIN} .

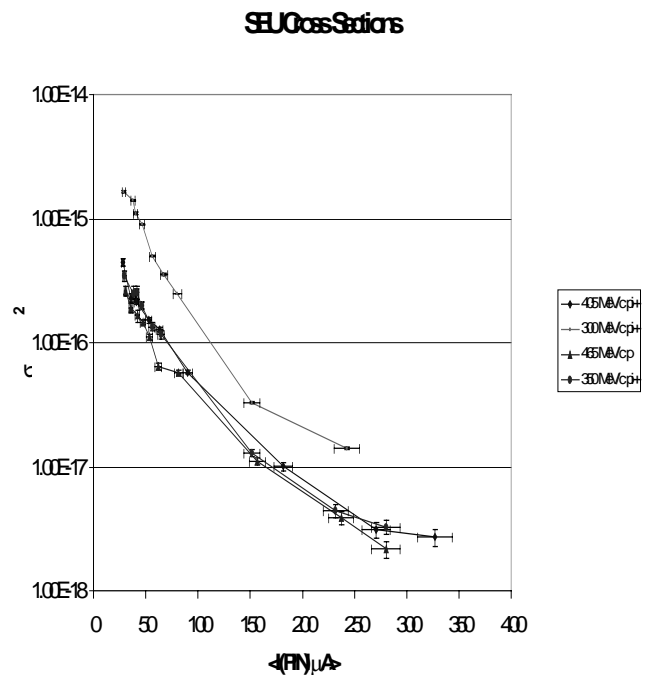

Figure 2 Measured SEU cross sections as a function of I_{PIN} .

showing that the errors were occurring in the TTC links. The errors probably occur due to nuclear interactions giving large energy depositions in the active volume of the PIN diode. The larger cross section at a momentum of 300 MeV/c could be due to the Delta resonance. A pessimistic estimation of the induced BER rate for the SCT was performed by taking the cross section at a momentum of 300 MeV/c, the minimum optical signal expected and the maximum flux expected of $2 \cdot 10^6 \text{ cm}^{-2} \text{ s}^{-1}$. This gave a BER of approximately $6 \cdot 10^{-10}$ which is within the system specifications.

IV. ON-DETECTOR OPTO-PACKAGES

Two versions of the on-detector opto-package have been successfully constructed and the results are described below. Both versions use VCSELs and epitaxial silicon PIN diodes, operating at 850 nm, which have been

demonstrated to be very radiation hard (see Section III). The ATLAS SCT style opto-package contains two VCSELs and one PIN diode. The packaging contains non-magnetic, low Z materials.

Marconi Package Construction

These packages¹ are based on silicon v-groove technology for passive alignment of the fibres to the VCSEL²s and PINs³. The package is divided into a base with the opto-electronics and a silicon lid containing the fibres (see Figure 3 below).

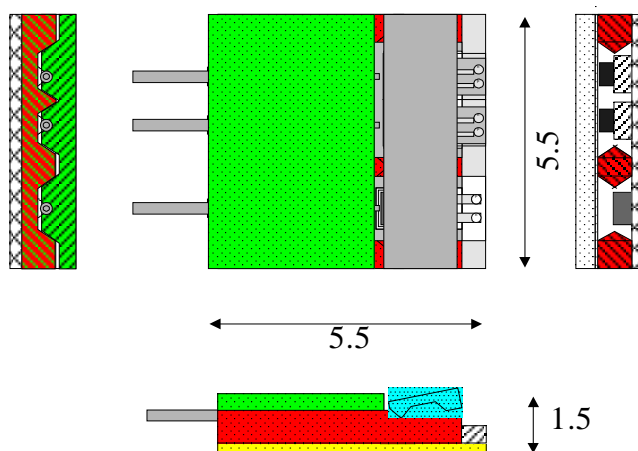

Figure 3 Schematic view of the Marconi opto-package.

The VCSELs are mounted on an AlN sub-mount. Only VCSELs which survive 100 hours of burn-in tests are used in the assembly. The PIN diodes are mounted on the alumina base board. The PIN responsivity is measured on the base board and only good PINs are used in the subsequent assembly. The three fibres are placed in the v-grooves in the silicon lid which can then be inserted into the base. An aluminised silicon mirror is used to reflect the light from (to) the VCSELs(PINs) into the fibre. A reference lid can be used to make a temporary connection to perform measurements before the actual lid is glued in place.

Marconi Package Tests.

A batch of 66 of these packages was assembled of which 60 satisfied the ATLAS specifications. The mean responsivity of the PIN diodes was 0.49 A/W, The average total power of the VCSELs after burn-in, when driven at 10 mA was 1.18 mW. The mean coupling efficiency into the fibre was 61%. The distribution of

fibre coupled power is shown in Figure 4 below. The mean coupled power was 0.72 mW. There is a very large spread in values, mainly due to the variation in the VCSELs, however the resulting yield for devices to satisfy the ATLAS requirement (300 μW at 10 mA) is very high.

VCSEL output power (after burn-in)

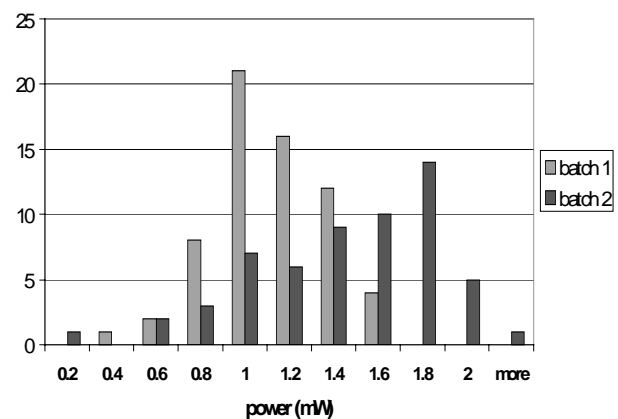

Figure 4 Distribution of fibre coupled power for VCSELs driven at 10 mA in the Marconi opto-package.

Some of the packages have been integrated into the SCT system and their performance evaluated. They were glued onto the SCT Cu/kapton “dog-leg” cables and bonded out to the VDC and DORIC4 ASICs. Extensive BER testing was performed on these packages using the system described in ref[2]. One of the possible critical problems with this design is the cross-talk between the emitters and the nearby receivers. This was minimised by the use of ground areas on the base plate which separated the PIN diode from the VCSELs. The effects of cross-talk were studied by measuring the BER for the TTC link, with and without simultaneous pulsing of the VCSELs at their maximum current of 20 mA, at a frequency of 20 MHz (corresponding to the maximum frequency for 40 Mbits/s NRZ data). No difference was detected in the BER when the VCSELs were pulsed from which one can conclude that the effects of cross-talk are negligible. A scan of BER as a function of the mean PIN diode current is shown in Figure 4 below. The BER can be seen to fall below the ATLAS specifications for a PIN current below the minimum current specified for DORIC4 operation (30 μA). At higher currents no errors were observed and the resulting 90% c.l. upper limits are well below the ATLAS specification for the BER of less than 10⁻⁹. In ATLAS

¹ Produced by Marconi Materials Technology, Caswell, Towcester, U.K.

² MITEL 1A444 VCSELs.

³ Centronic APEX10, epitaxial Si PIN diodes.

operation at high luminosity the BER is expected to be dominated by the SEU effects discussed in Section III.

Two of these opto-packages were irradiated to a fluence of 3×10^{14} 24 GeV protons at the CERN PS and both VCSELs and PINs performed within ATLAS specifications. Tests were also performed of these packages at the lower temperatures expected during ATLAS operation. The PIN diodes showed an increased full depletion voltage and a decreased responsivity. The VCSELs showed an increase in the threshold current but most of this could be annealed by operating at 20 mA for a few hours. However the performance of both PINs and VCSELs remained within the ATLAS specifications.

BER Stats

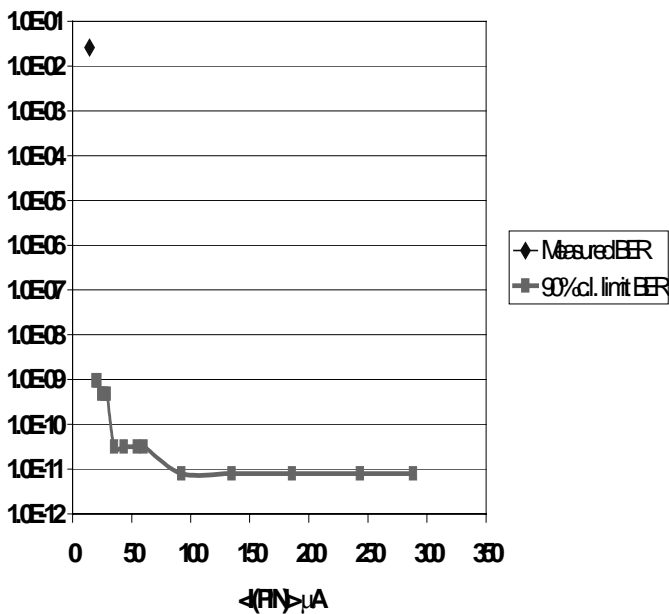

Figure 5 BER for the Marconi opto-package integrated into the SCT system as a function of the mean PIN diode

Taiwan Package Construction

Similar functionality ATLAS style opto-packages containing 2 VCSELs and one PIN diode have also been assembled in Taiwan⁴. Opto-packages have been assembled using the same VCSELs and PINs as used for the Marconi opto-packages. The same packaging style has also been used with VCSELs and epitaxial silicon PIN diodes from Truelight⁵. The concept for the package is based on mounting the VCSELs and PINs on simple (and cheap) PCBs, then using 45° angle polished fibre to

⁴ Radientech, Taipei, Taiwan.

⁵ Truelight, Taipei, Taiwan.

couple the light from (to) the VCSELs (PINs) into (from) the fibre as illustrated in Fig 6 below.

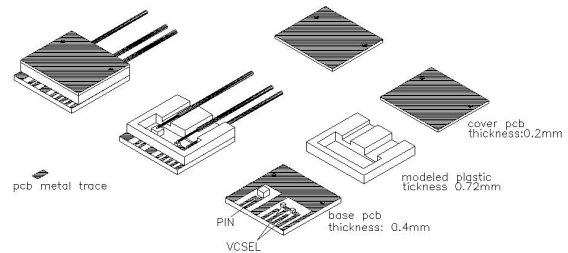

Figure 6 Taiwan opto-package assembly.

The fibres are illuminated by a red laser and an x-y stage is used to move the fibre until the light spot is centred on the active region of the VCSEL or the PIN. The fibres are then glued into place.

Taiwan Package Tests

Several batches of these type of opto-packages have been assembled. From a batch of 25 packages assembled using 50 VCSELs and 25 PINs the mean total power of the VCSELs when driven at 10 mA was 1540 μW. The mean coupling efficiency was 58%. The mean fibre coupled power was 890 μW. The distribution of fibre coupled power is shown in Fig 6 below. This shows a very broad distribution but the yield for devices satisfying the ATLAS specifications is also very high.

Coupled Power

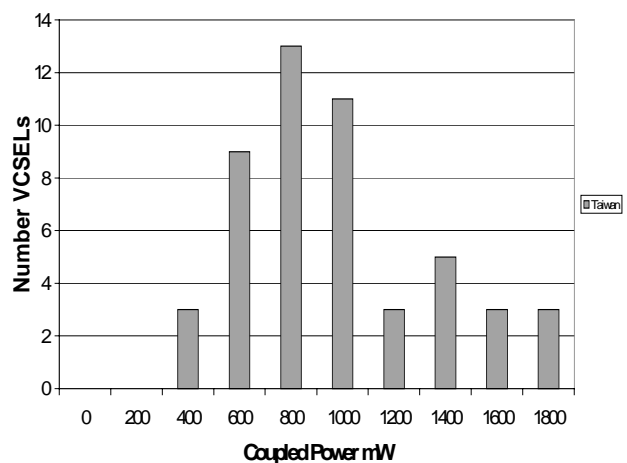

Figure 7 Distribution of the fibre coupled power for VCSELs driven at 10 mA in the Taiwan opto-package.

of cross-talk were studied in the same way and again there was no evidence for any significant cross-talk. The BER for the TTC link was measured as a function of the mean PIN diode current and the results shown in Fig 7 below.

The BER falls is lower than the ATLAS specification of 10^{-9} for a PIN current of $30 \mu\text{A}$ corresponding to the minimum specified for DORIC4 operation. At higher values of the PIN current, no errors were observed and the resulting 90% c.l. upper limits are well below the ATLAS specification.

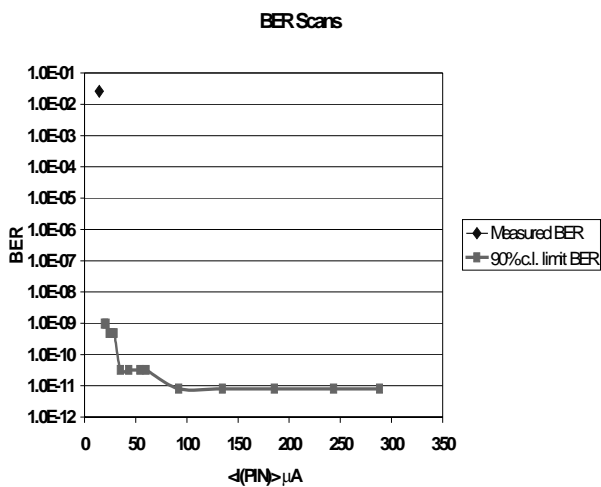

Figure 8 BER versus the mean PIN current for the Taiwan Opto-package.

V. OPTO-HARNESS

For the barrel SCT the opto-electronics and electrical services for six modules will be combined into one opto-harness. This consists of 6 low mass aluminium on kapton power tapes, 6 copper/kapton “dog-leg” cables and the associated fibre. Each dog-leg cable has an opto-package and associated DORIC4 and VDC ASICs.

Many problems were encountered with the first prototype harness. These were mainly due to the quality control of PIN diodes and the methods used for joining the fibres from the pig-tailed packages to the ribbon fibres. A further harness will be assembled using Taiwan opto-packages with improved procedures based on the lessons learnt from the first harness.

A second harness is now being assembled using Marconi opto-packages. The base of the opto-packages and the ASICs were mounted and bonded on “dog-leg” cables. These were tested individually using a temporary insertion of a silicon lid with 3 fibres.

All 6 dog-legs performed according to ATLAS specifications. And

VI. CONCLUSIONS

Radiation hard opto-electronics has been successfully developed for the read out of the ATLAS SCT and Pixel detectors. The radiation testing for the SCT is nearly complete but some higher fluence studies are still required to verify the use of the VCSELs in the Pixel detector. SEU studies have shown that there will be a measurable BER during ATLAS operation, but that the rate can be managed. Two versions of a low mass, non-magnetic, radiation-hard on-detector opto-package have been developed. Both versions have been integrated into the SCT system and demonstrated to meet the ATLAS SCT specifications. The first attempts at integration of a larger part of the SCT system have shown that there is still more work to do before production can start.

VII. ACKNOWLEDGEMENTS

We acknowledge financial help from the UK Particle Physics and Astronomy Research Councils. We thank Ian McGill (Birmingham University), Paul Pattinson (Oxford University), Jeff Bizzel (RAL) and Craig Macwaters (RAL) for technical assistance.

References

1. ATLAS Inner Detector TDR, CERN/LHCC/97-16.
2. D.G. Charlton et al., Nucl. Instr. Meth. A443 (2000) 430.
3. See [www](http://www.pnp.physics.ox.ac.uk/~weidberg/fluences.html) at url: <http://www.pnp.physics.ox.ac.uk/~weidberg/fluences.html>
4. J.D. Dowell et al., Radiation Hardness and Lifetime Studies of the Photodiodes for the Optical Readout of the ATLAS SCT. Accepted for publication in Nucl. Instr. Meth. A.
5. See [www](http://www.atlas.uni-wuppertal.de/optolink/wuppertal/annealing.html) at url: <http://www.atlas.uni-wuppertal.de/optolink/wuppertal/annealing.html>.
6. Radiation Hardness Studies of the Front-end ASICs for the Optical Links of the ATLAS Semiconductor Tracker. Accepted for publication in Nucl. Instr. Meth. A.
7. G. Mahout et al, Nucl. Instr. Meth. A 446 (2000) 426.