

LONGITUDINAL BEAM DYNAMICS IN CIRCULAR ACCELERATORS

J. Le Duff

Laboratoire de l'Accélérateur Linéaire
Université Paris-Sud, 91405 Orsay, France

1. ACCELERATION BY TIME VARYING FIELDS

1.1 Time varying magnetic field: the betatron concept

The betatron accelerator is the only circular machine which uses a time varying magnetic field to accelerate the particle. It is typically an induction accelerator. Notice that induction linear accelerators are also used.

The betatron, as shown on Fig. 1, is a very simple machine which consists of a magnet fed by an alternating current at a frequency usually between 50 to 200 Hz. The magnet poles which surround the vacuum chamber where particles circulate are truncated cones. In this machine the magnetic field is used for guiding the particles on a circular trajectory as well as for acceleration.

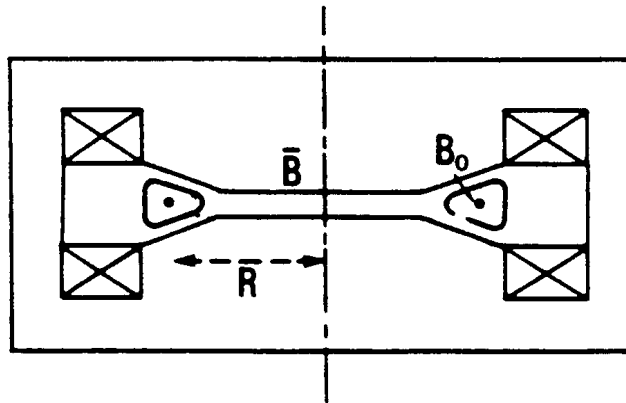

Fig. 1 The betatron scheme

The variable magnetic field produces an electric field component according to Maxwell's equations:

$$E = -\text{grad}V - \frac{\partial A}{\partial t}$$
$$B = \mu H = \text{curl} A$$

In the present case where there is no scalar potential, and according to the field symmetry, one has:

$$V = 0$$
$$A_r = A_z = 0 \quad A_\theta = A(r, z, t)$$
$$E_\theta = -\frac{\partial A_\theta}{\partial t}$$

showing that the electric field is tangent to the circular orbit defined by

$$B_0 R = -p/e$$

where e is the algebraic particle charge.

Moreover, from the single component A_θ one gets the magnetic field components:

$$\begin{aligned} B_r &= -\frac{\partial A}{\partial z} \\ B_\theta &= 0 \\ B_z &= \frac{1}{r} \frac{\partial}{\partial r}(rA) = A' + \frac{A}{r} \end{aligned}$$

The flux of B linking any circle $r = cte$ is then:

$$\Phi = \int_0^r B_z 2\pi r \, dr = 2\pi \int_0^r \frac{1}{r} \frac{\partial}{\partial r}(rA) r \, dr = 2\pi r A .$$

Denoting by \bar{B}_z the average field value inside the circle, the flux will be also:

$$\Phi = \pi r^2 \bar{B}_z$$

which shows that:

$$A = \frac{1}{2} r \bar{B}_z .$$

Then one gets:

$$E_\theta = -\frac{\partial A}{\partial t} = -\frac{1}{2} \frac{\partial}{\partial t}(r \bar{B}_z) = -\frac{r}{2} \frac{\partial}{\partial t} \bar{B}_z .$$

Putting $r = R$ the voltage over one turn is:

$$2\pi R E_\theta = -\pi R^2 \frac{d\bar{B}_z}{dt} = -\frac{d\Phi}{dt}$$

which is a well known law in electronics that a time variation of the flux induces a voltage. The induction accelerator is often considered as a transformer in which the primary current is the alternating current and the secondary current is the circulating electron beam.

The acceleration is given by the Newton-Lorentz equation:

$$\begin{aligned} \frac{dp}{dt} &= e E_\theta \\ \frac{dp}{dt} &= -\frac{e}{2\pi R} \frac{d\Phi}{dt} = -\frac{1}{2} e R \frac{d\bar{B}_z}{dt} \end{aligned}$$

If one wants to keep the particle on the same trajectory the following relation must also be fulfilled:

$$\frac{dp}{dt} = -e R \frac{dB_0}{dt}$$

and hence

$$B_0 = \frac{1}{2} \bar{B}_z + cte$$

which is the betatron relation.

1.2 Time varying electric field: the cyclotron case

The cyclotron is an example of a circular accelerator using a radio frequency accelerating field. A magnet (Fig. 2a) produces a constant B field in the useful area for the particle trajectories. The box in which the particles circulate is divided into two pieces, separated by a gap (Fig. 2b) fed with an RF signal which produces an alternating electric field.

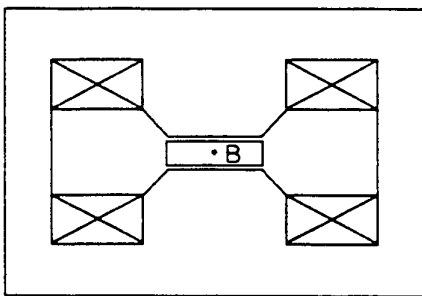

Fig. 2a Cyclotron magnet

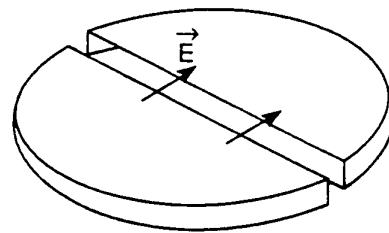

Fig. 2b Shape of electrodes

Each time the particle crosses the gap it experiences an accelerating force provided the phase of the RF has the right polarity. After each crossing the particle, with velocity v , follows a circular trajectory with radius r , due to the vertical magnetic field perpendicular to the particle velocity:

$$r = \frac{mv}{eB}$$

Having described half a circle the particle comes back through the gap and is accelerated once more provided the field polarity has reversed. Since the magnetic field is constant the particle trajectory will spiral as shown in Fig. 3.

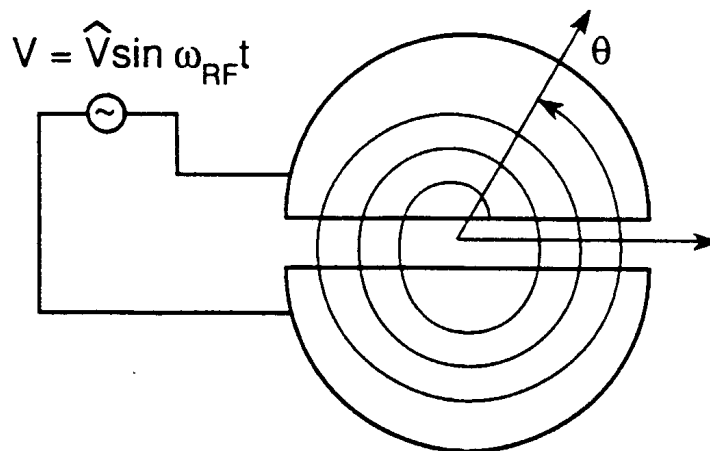

Fig. 3 Cyclotron orbit

A synchronism condition for the accelerator is obtained by proper choice of the RF frequency:

$$\omega_{RF} = \omega_r = \frac{eB}{m}$$

where ω_r is the angular revolution frequency and m the mass. However, since standard cyclotrons have a fixed RF frequency, this relation can only be satisfied for constant mass, which implies non-relativistic particles:

$$m = m_0 .$$

This would be the case for instance, for heavy particles (protons and ions) for which the kinetic energy remains small compared to the rest energy.

Within the previous assumptions the cyclotron would remain a rather low energy machine. So let us consider the case of higher energies where particles become relativistic. At each transit in the gap the energy gain is:

$$\Delta E = e\hat{V} \sin \phi$$

where ϕ is the phase of the particle with respect to the RF phase:

$$\phi = \omega_{RF}t - \theta$$

θ being the azimuthal angle of the trajectory. Differentiating with respect to time gives:

$$\dot{\phi} = \omega_{RF} - \omega_r$$

or

$$\dot{\phi} = \omega_{RF} - ec^2 \frac{B}{E}$$

It is seen that with ω_{RF} and B constant, it is not possible to have a synchronous particle with $\phi = \text{cte}$ ($\dot{\phi} = 0$). The formula shows that ϕ starts decreasing, reaches a minimum value ($\dot{\phi} = 0$) and then increases. Notice that the maximum tolerable ϕ range of variation during acceleration is π .

Since phase and energy are related let us now consider their evolution during the acceleration cycle. A smooth approximation consists of assuming that the acceleration is made continuously, hence:

$$\dot{\phi} = \frac{\Delta\phi}{T_r/2} = \frac{\omega_r}{\pi} \Delta\phi$$

where $\Delta\phi$ is the relative phase change at each half revolution, T_r being the revolution period. Hence one obtains:

$$\Delta\phi = \frac{\pi}{\omega_r} \dot{\phi} = \pi \left(\frac{\omega_{RF}}{\omega_r} - 1 \right)$$

$$\Delta\phi = \pi \left(\frac{\omega_{RF}E}{ec^2B} - 1 \right)$$

Differentiating the phase with respect to the energy, within the smooth approximation, leads to:

$$\frac{d\phi}{dE} \approx \frac{\Delta\phi}{\Delta E} = \frac{\pi}{e\hat{V} \sin \phi} \left(\frac{\omega_{RF} E}{ec^2 B} - 1 \right)$$

or

$$d(\cos \phi) = -\frac{\pi}{e\hat{V}} \left(\frac{\omega_{RF} E}{ec^2 B} - 1 \right) dE$$

Integrating both sides gives the energy-phase equation of the cyclotron:

$$\cos \phi = \cos \phi_0 - \frac{\pi}{e\hat{V}} \left[\frac{\omega_{RF}}{2ec^2 B} (E^2 - E_0^2) - (E - E_0) \right]$$

where index 0 refers to the initial conditions:

E_0 = rest energy

ϕ_0 = injection phase

It is interesting to represent on a graph the phase-energy evolution. Using the kinetic energy $W = E - E_0$ as the new variable one gets:

$$\cos \phi = \cos \phi_0 + \frac{\pi}{e\hat{V}} \left(1 - \frac{\omega_{RF}}{\omega_{r0}} \right) W - \frac{\pi}{2e\hat{V}E_0} \frac{\omega_{RF}}{\omega_{r0}} W^2$$

where $\omega_{r0} = ec^2 B/E_0$ is the starting revolution frequency.

Figure 4 shows the variation of $\cos \phi$ as a function of W for different initial conditions ϕ_0 . Plots which, during acceleration remain within the range $-1 < \cos \phi < 1$, only are meaningful from the stability point of view.

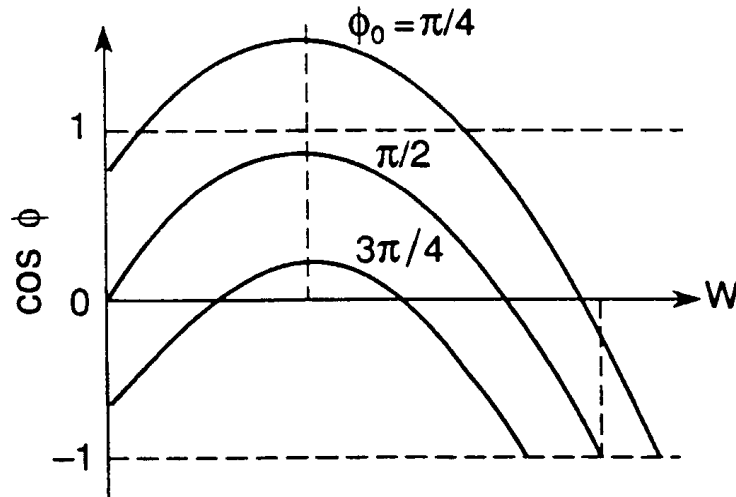

Fig. 4 Energy-phase diagram

Selected particles, according to their initial phase ϕ_0 can reach high energies, ;but the cyclotron is nevertheless limited in energy as seen in the figure. The machine parameters must be chosen to obtain the largest useful ϕ_0 range. This implies for instance $\omega_{RF} < \omega_{r0}$ but it also depends very much on the particle species.

In the attempt to reach higher energies the concept of the synchrocyclotron has been quite important. Here the RF frequency is varied to keep the synchronous condition during acceleration. A new limitation however occurs due to the size of the magnet. A more efficient synchronous machine is the so-called synchrotron, which will be treated in more detail in the next sections.

1.3 Time varying electric field: the synchrotron case

A synchrotron is a circular accelerator where the nominal particle trajectory is kept at a constant physical radius by means of a magnetic field variation, as well as an RF frequency variation, to follow the energy variation.

Let's assume now that an RF cavity with an electric field component parallel to the particle trajectory is located at some azimuthal position of such a circular accelerator. In the cavity gap the electric field is supposed to have a sinusoidal time variation with angular frequency ω_{RF} . Then one can write:

$$E(z, t) = E_1(z)E_2(t)$$

where $E_1(z)$ is shown on Fig. 5 as a periodic function of period $L = 2\pi R$, while $E_2(t)$ is of the form:

$$E_2(t) = E_0 \sin \left(\int_{t_0}^t \omega_{RF} dt + \phi_0 \right)$$

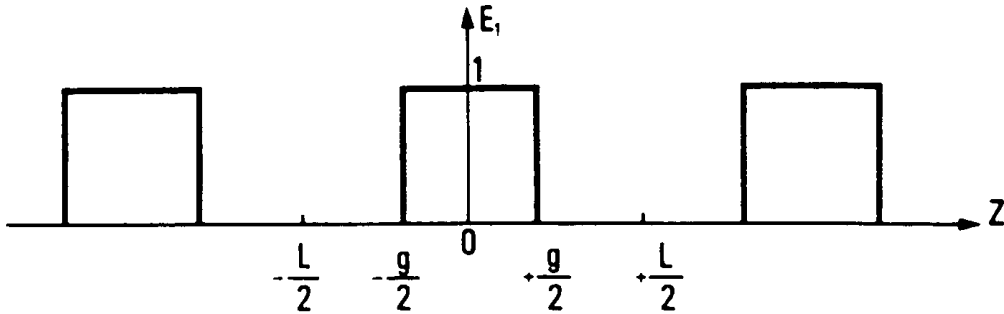

Fig. 5 RF field envelope along the circumference

The particle position is given by:

$$z = z_0 + \int_{t_0}^t v dt$$

and the RF frequency is chosen to be an integer multiple of the revolution frequency:

$$\omega_{RF} = h\omega_r = h \frac{2\pi v}{L}$$

where v is considered here as the average particle velocity over one turn.

The periodic function $E_1(z)$ can be expanded in a Fourier series:

$$E_1(z) = A_0 + \sum_{n=1}^{\infty} A_n \cos\left(n \frac{2\pi z}{L}\right)$$

with

$$A_0 = \frac{g}{L}$$

$$A_n = \frac{2}{\pi n} \sin \frac{\pi n g}{L}$$

The integral of the force over many revolutions shows that all the trigonometric terms in the expansion will give no effective contribution to the energy gain, apart from a single term which corresponds to $n = h$. Then the average energy gain per turn can be written:

$$W = e \int_{-g/2}^{+g/2} E_1(z) E_2(t) dz = e E_0 g \sin \left(\int_{t_0}^t \omega_{RF} dt + \phi_0 \right)$$

with

$$\psi_0 = \phi_0 - \frac{2\pi h z_0}{L}$$

$$W = e E_0 \int_{-L/2}^{+L/2} A_h \cos^2 \frac{2\pi h z}{L} \sin \psi_0 \cdot dz$$

$$W = \frac{e E_0 A_h L}{2} \sin \psi_0 = \frac{e E_0 L}{\pi h} \sin \frac{\pi h g}{L} \sin \psi_0$$

$$W = e E_0 g \frac{\sin \frac{\pi h g}{L}}{\frac{\pi h g}{L}} \sin \psi_0 \cong e E_0 g \sin \psi_0 \quad \text{for } g \text{ small enough}$$

The energy gain per turn can also be expressed as:

$$W = e \int_{-g/2}^{+g/2} E_1(z) E_2(t) dz = e E_0 g \sin \left(\int_{t_0}^t \omega_{RF} dt + \phi_0 \right)$$

and since the gap center is at $z = 0$ one has:

$$W = e E_0 g \sin \psi_0 = \hat{V} \sin \psi_0$$

showing that ψ_0 represents the RF phase seen by the particle when crossing the gap.

From above it is seen that the force acting on the particle can be considered as an average force, continuously acting on the particle all over the circumference, provided the initial phase of the particle entering the gap is maintained constant. In other words the effect is equivalent to a force given by a travelling wave propagating at the same velocity as the particle velocity.

Since only one harmonic of the Fourier expansion is acting effectively, one can write the equivalent field as:

$$E = E_0 A_h \cos \frac{2\pi h z}{L} \sin \left(\int \omega_{\text{RF}} dt + \phi_0 \right)$$

$$E = \frac{E_0}{2} A_h \left\{ \sin \left(\int \omega_{\text{RF}} dt + \phi_0 - \frac{2\pi h z}{L} \right) + \sin \left(\int \omega_{\text{RF}} dt + \phi_0 + \frac{2\pi h z}{L} \right) \right\}$$

where the first term in the bracket represents a travelling wave with wavelength $\lambda = L/h$ and phase velocity equal to the particle velocity, while the second term in the bracket gives no effect on a time average.

2. DISPERSION EFFECTS DUE TO THE GUIDE FIELD IN A SYNCHROTRON

2.1 Momentum compaction

By definition the momentum compaction α is the constant parameter which relates the variation of the orbit length of a particle, in a circular accelerator, to the momentum deviation (note that the nominal closed orbit has been defined for the nominal energy E).

$$\alpha = \frac{p}{L} \frac{dL}{dp} = \frac{p}{R} \frac{dR}{dp}$$

where p , L and R are respectively the particle momentum, the nominal circumference and the physical radius ($2\pi R = L$).

One has:

$$E = \gamma m_0 c^2 = (1 - \beta^2)^{-1/2} m_0 c^2$$

$$p = mv = \gamma \beta \frac{m_0 c^2}{c} = \beta (1 - \beta^2)^{-1/2} \frac{m_0 c^2}{c}$$

$$E = \frac{pc}{\beta}$$

and by logarithmic differentiation one gets:

$$\frac{dE}{E} = \frac{dp}{p} - \frac{d\beta}{\beta}$$

$$\frac{dp}{p} = \frac{d\beta}{\beta} + \frac{1}{2} \frac{2\beta d\beta}{1 - \beta^2} = \frac{d\beta}{\beta} \left(1 + \frac{\beta^2}{1 - \beta^2} \right) = \frac{d\beta}{\beta} (1 - \beta^2)^{-1}$$

$$\frac{dE}{E} = \frac{dp}{p} - (1 - \beta^2) \frac{dp}{p} = \beta^2 \frac{dp}{p}$$

which leads to:

$$\frac{E}{R} \frac{dR}{dE} = \frac{\alpha}{\beta^2}$$

The average magnetic field along the nominal closed orbit is given by:

$$\begin{aligned}\langle B_{c.o.} \rangle &= \frac{1}{2\pi R} \oint B_{c.o.} ds \\ &= \frac{p/e}{2\pi R} \oint \frac{ds}{\rho} = \frac{p/e}{R} \quad (\rho = \text{bending radius})\end{aligned}$$

$$\langle B_{c.o.} \rangle R = p/e$$

and by differentiating

$$\begin{aligned}\frac{d\langle B_{c.o.} \rangle}{\langle B_{c.o.} \rangle} + \frac{dR}{R} &= \frac{dp}{p} \\ \frac{p}{\langle B_{c.o.} \rangle} \frac{d\langle B_{c.o.} \rangle}{dp} &= 1 - \alpha\end{aligned}$$

or

$$\frac{R}{\langle B_{c.o.} \rangle} \frac{d\langle B_{c.o.} \rangle}{dR} = \frac{1 - \alpha}{\alpha}$$

Exercise: calculation of α

Consider an isomagnetic guide field where all the bending magnets have the same curvature $1/\rho$ and are separated by straight sections ($1/\rho = 0$) which can include quadrupole magnets. To first-order approximation only the curved part of the orbit in the bendings contributes to a change of the length of the trajectory with momentum.

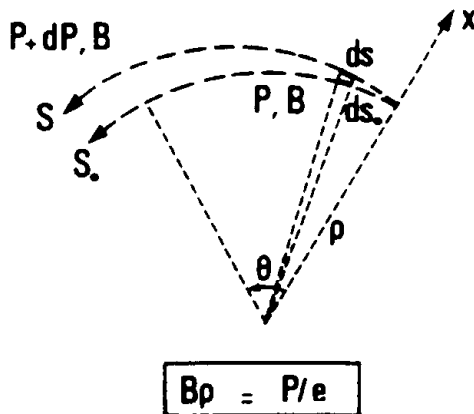

In a bending magnet one has:

$$\begin{aligned}ds_0 &= \rho d\theta \\ ds &= (\rho + x) d\theta \\ \frac{ds - ds_0}{ds_0} &= \frac{d\ell}{ds_0} = \frac{x}{\rho} = \frac{dx_{c.o.}}{\rho}\end{aligned}$$

The radial change in closed orbit with momentum is given by:

$$D_x = \frac{dx_{c.o.}}{dp/p}$$

where D_x is the dispersion function (or local momentum compaction factor). A summation of all these small changes in the orbit length will give the change in the circumference.

$$\begin{aligned}\int d\ell &= dL = 2\pi dR \\ dR &= \frac{1}{2\pi} \int d\ell = \frac{1}{2\pi\rho} \int_m x ds_0 = \langle x \rangle_m\end{aligned}$$

where the subscript m means that the integral has to be calculated in the magnets only where $1/\rho \neq 0$. Finally one gets:

$$\alpha = \frac{p}{R} \frac{dR}{dp} = \frac{p}{R} \frac{\langle x \rangle_m}{dp} = \frac{\langle D_x \rangle_m}{R}$$

It can be shown that in smooth machines

$$\alpha \cong 1/Q_x^2$$

where Q_x is the radial wavenumber. In most cases however $\langle D_x \rangle_m$ has to be numerically computed from lattice programmes.

2.2 Revolution frequency versus momentum

If f_r is the nominal revolution frequency corresponding to the nominal energy E (or momentum p), the parameter η will be defined as follows:

$$\eta = \frac{p}{f_r} \frac{df_r}{dp}$$

Since

$$f_r = \frac{\beta c}{2\pi R}$$

one gets

$$\frac{df_r}{f_r} = \frac{d\beta}{\beta} - \frac{dR}{R} = (1 - \beta^2) \frac{dp}{p} - \alpha \frac{dp}{p}$$

$$\frac{df_r}{f_r} = \left(\frac{1}{\gamma^2} - \alpha \right) \frac{dp}{p}$$

and hence

$$\eta = \frac{1}{\gamma^2} - \alpha$$

For an electron machine $\eta \cong -\alpha$

2.3 Transition energy

The transition energy γ_{tr} is the energy which corresponds to $\eta = 0$

$$\frac{1}{\gamma_{tr}^2} = \alpha$$

$$\gamma_{tr} = \sqrt{1/\alpha} \cong Q_x$$

For small machines Q_x is of the order of a few units, while for very large machines it can approach 100. Hence, γ_{tr} will be in the range of 1 to 100 which is of interest only for proton machines because for electron machines $\gamma \gg \gamma_{tr}$.

Indeed it is possible in electron storage rings to make α very small by using special focussing to make the transverse emittance very small as required for instance by synchrotron radiation users. In that case it is necessary to look to higher order in dp/p to get correct

dispersion relations. There are specific problems in proton synchrotrons related to the crossing of the transition energy which can be found in another lecture.

3. SYNCHROTRON OSCILLATION IN ADIABATIC LIMIT

One will consider the acceleration of particles with a radio frequency (RF) electric field which has a resonant condition with the nominal revolution frequency, or at least approximately.

3.1 Synchronous particle

The accelerating voltage across the gap of the RF cavity can be expressed as:

$$V = \hat{V} \sin \int_0^t \omega_{RF} dt' = \hat{V} \sin \phi(t)$$

where \hat{V} and ω_{RF} are slowly varying functions of t , but can also be constant as for instance in storage rings.

The RF frequency f_{RF} is set up to be an integer multiple of the nominal revolution frequency f_r

$$f_{RF} = hf_r$$

where h is called the harmonic number. In these conditions a particle which has the nominal energy and circulates on the nominal trajectory will always experience the same RF phase when passing the RF gap:

$$\phi(t) = \phi_s$$

It is called the synchronous phase and it is related to the synchronous particle.

During the acceleration in a synchrotron the energy of the synchronous particle varies and so does the revolution frequency (unless particles are ultra relativistic). Clearly, if one wants to keep the accelerated particle on the same trajectory ($R = cte$) the magnetic field must vary with time:

$$e\langle B \rangle R = p = m_0 c \beta \gamma = m_0 c \beta (1 - \beta^2)^{-1/2}$$

$$\frac{dp}{dt} = eR \frac{d\langle B \rangle}{dt} = eR \langle \dot{B} \rangle$$

The energy gain per turn for the synchronous particle is:

$$(\Delta p)_{turn} = eR \langle \dot{B} \rangle T_r$$

where T_r is the revolution period:

$$T_r = \frac{1}{f_r} = \frac{2\pi R}{\beta c}$$

Hence:

$$(\Delta p)_{turn} = \frac{2\pi e R^2}{\beta c} \langle \dot{B} \rangle = \frac{2\pi e \rho R}{\beta c} \dot{B}$$

Since:

$$\Delta(E^2) = \Delta(p^2 c^2)$$

one gets:

$$\Delta E = \beta c \Delta p$$

and

$$(\Delta E)_{turn} = 2\pi e \rho R \dot{B}$$

where the energy gain per turn is obtained from the RF cavity:

$$(\Delta E)_{turn} = e \hat{V} \sin \phi_s$$

Exercise

Assume a 10 GeV proton synchrotron where the magnetic field reaches 1.5 Tesla in one second, following a linear variation. For a 10 GeV proton kinetic energy one has:

$$pc = (E^2 - m_0 c^2)^{1/2} = 10.9 \text{ GeV}$$

$$\beta = 0.996 ; \quad \gamma = 11.7$$

hence

$$B\rho = P/e = 36.4 \text{ T.m}$$

and

$$\rho = 24 \text{ m} \quad (R \cong 1.5\rho = 36 \text{ m})$$

As a result:

$$\hat{V} \geq 8.14 \text{ kVolts} \quad (e\hat{V} \sin \phi_s \ll m_0 c^2)$$

Notice that in an electron synchrotron the particle radiates some energy per turn, and the amount of energy gain per turn must be greater than this loss in order to get an acceleration process.

3.2 Non-synchronous particle

In the following the parameters of the synchronous particle will be defined by subscript s. Any other particle will then be defined by its deviation from the synchronous one:

revolution frequency: $f_r = f_{rs} + \Delta f_r$ (or $\omega = \omega_s + \Delta\omega$)

RF phase: $\phi = \phi_s + \Delta\phi$

momentum: $p = p_s + \Delta p$

energy: $E = E_s + \Delta E$

azimuthal angle: $\theta = \theta_s + \Delta\theta$

The azimuthal angle is related to the azimuthal position by $ds = R d\theta$. Over one revolution this angle varies by 2π while the RF phase varies by the quantity $2\pi h$. Hence, one has:

$$\Delta\phi = -h\Delta\theta$$

The - sign comes from the fact that a particle behind the synchronous particle ($\Delta\theta < 0$) arrives later in the gap ($\Delta t > 0$ and $\Delta\phi > 0$). Moreover, since $\theta = \int \omega dt$, one has:

$$\Delta\omega = \frac{d}{dt}(\Delta\theta) = -\frac{1}{h} \frac{d}{dt}(\Delta\phi) = -\frac{1}{h} \frac{d\phi}{dt}$$

and from the definition of η

$$\Delta p = -\frac{p_s}{h\eta\omega_s} \dot{\phi}$$

This can also be expressed in terms of energy:

$$\Delta E = \frac{dE}{dp} \Delta p = v \Delta p = \omega R \Delta p$$

$$\frac{\Delta E}{\omega} = -\frac{pR}{h\eta\omega} \dot{\phi}$$

On each revolution the particle gains the energy:

$$(\Delta E)_{turn} = e\hat{V} \sin \phi$$

which corresponds to the momentum increment:

$$(\Delta p)_{turn} = \frac{e\hat{V}}{\omega R} \sin \phi$$

Dividing by the revolution period one gets the rate per second:

$$\dot{p} = \omega \frac{(\Delta p)_{turn}}{2\pi} = \frac{e\hat{V}}{2\pi R} \sin \phi$$

or

$$2\pi R \dot{p} = e\hat{V} \sin \phi$$

and for the synchronous particle:

$$2\pi R_s \dot{p}_s = e\hat{V} \sin \phi_s$$

By subtracting the two last expressions one gets:

$$2\pi\Delta(R\dot{p}) = e\hat{V}(\sin \phi - \sin \phi_s)$$

Expanding the left hand side to first order in ΔR and $\Delta\dot{p}$ gives:

$$\begin{aligned}
\Delta(R\dot{p}) &= R\dot{p} - R_s\dot{p}_s = (R_s + \Delta R)(\dot{p}_s + \Delta\dot{p}) - R_s\dot{p}_s \\
&\cong \dot{p}_s\Delta R + R_s\Delta\dot{p} \\
&\cong \dot{p}_s\left(\frac{dR}{dp}\right)_s \Delta p + R_s\Delta\dot{p} \\
&\cong \dot{R}_s\Delta p + R_s\Delta\dot{p} = \frac{d}{dt}(R_s\Delta p) = \frac{d}{dt}\left(\frac{\Delta E}{\omega_s}\right)
\end{aligned}$$

The motion of any arbitrary particle in terms of deviations from the synchronous particle is then expressed by the following set of first order differential equations:

$$\begin{aligned}
\frac{dW}{dt} &= e\hat{V}(\sin\phi - \sin\phi_s) \\
\frac{d\phi}{dt} &= -\frac{1}{2\pi} \frac{h\eta\omega_s}{p_s R_s} W
\end{aligned}$$

where the new variable $W = 2\pi R_s \Delta p = 2\pi \Delta E/\omega_s$ has been introduced.

It is worthwhile mentioning that the two variables ϕ , W are canonical since the equations of motion can be derived from a Hamiltonian $H(\phi, W, t)$:

$$\begin{aligned}
\frac{d\phi}{dt} &= \frac{\partial H}{\partial W} \\
\frac{dW}{dt} &= -\frac{\partial H}{\partial \phi}
\end{aligned}$$

with:

$$H(\phi, W, t) = e\hat{V}[\cos\phi - \cos\phi_s + (\phi - \phi_s)\sin\phi_s] - \frac{1}{4\pi} \frac{h\eta\omega_s}{R_s p_s} W^2$$

From the set of first-order equations of motion one can also derive a second-order differential equation for each variable. For instance the phase motion is given by:

$$\frac{d}{dt}\left[\frac{R_s p_s}{h\eta\omega_s} \frac{d\phi}{dt}\right] + \frac{e\hat{V}}{2\pi}(\sin\phi - \sin\phi_s) = 0$$

3.3 Small amplitude oscillations – phase stability

Let's consider the case where the parameters R_s , p_s , η , ω_s and \hat{V} are constant or at least change very slowly with time as compared to the variable $\Delta\phi = \phi - \phi_s$. Hence one can write:

$$\ddot{\phi} + \frac{\Omega_s^2}{\cos\phi_s}(\sin\phi - \sin\phi_s) = 0$$

where:

$$\Omega_s^2 = \frac{e\hat{V}h\eta\omega_s \cos\phi_s}{2\pi R_s p_s}$$

Within the approximation $\Delta\phi \ll 1$ the equation of motion for small amplitudes becomes:

$$\ddot{\phi} + \Omega_s^2 \Delta\phi = 0$$

where Ω_s now represents the synchrotron angular frequency. This quantity must be real in order to get a stable motion which means that $\eta \cos \phi_s$ has to be positive. Stable synchrotron phase motion needs the following conditions to be satisfied:

$$\begin{aligned} \gamma < \gamma_{tr} \quad \eta > 0 \quad 0 < \phi_s < \frac{\pi}{2} \quad \sin \phi_s > 0 \\ \gamma > \gamma_{tr} \quad \eta < 0 \quad \frac{\pi}{2} < \phi_s < \pi \quad \sin \phi_s > 0 \end{aligned}$$

having eliminated the cases where $\sin \phi_s < 0$ which correspond to a deceleration.

At transition energy η vanishes, Ω_s goes to zero and there is no more phase stability, at least within the first order approximation. During acceleration through transition energy, in a proton synchrotron, the RF phase must be switched rapidly from ϕ_s to $\pi - \phi_s$ in order to maintain stability above transition.

In the case of electron machines, either synchrotrons or storage rings, where the particle velocity is practically constant and equal to c , one has the following simplifications:

$$\begin{aligned} \omega_s = c/R_s \quad p_s = E_s/c \quad \eta \cong -\alpha \\ \Omega_s = \frac{c}{R_s} \left[-\frac{h\alpha \cos \phi_s e\hat{V}}{2\pi E_s} \right]^{1/2} \end{aligned}$$

The synchrotron tune which is the number of synchrotron oscillations per turn is represented by the bracket:

$$Q_s = \frac{\Omega_s}{c/R_s}$$

Note In an electron machine the RF frequency does not change and this is also true for R_s and ω_s .

3.4 Large amplitude oscillations – RF acceptance

Considering again the equation of motion:

$$\ddot{\phi} + \frac{\Omega_s^2}{\cos \phi_s} (\sin \phi - \sin \phi_s) = 0$$

multiplying by $\dot{\phi}$ and integrating lead to the invariant of the motion:

$$\frac{\dot{\phi}^2}{2} - \frac{\Omega_s^2}{\cos \phi_s} (\cos \phi + \phi \sin \phi_s) = cte$$

It is already known that around the stable synchronous phase ϕ_s the small amplitude motions are pure harmonic oscillations which correspond to circles in the frame $(\phi/\Omega_s, \phi)$. For larger

amplitudes the circles will be distorted by the non-linearity of the motion but the curves will still close on themselves (Fig. 6). The extreme elongations of the oscillation correspond to $\phi = 0$ and the constant of the motion can be expressed in terms of these values.

When ϕ reaches the value $\pi - \phi_s$ the factor $(\sin \phi - \sin \phi_s)$ in the equation of motion becomes zero and for higher values of ϕ the force is no more attractive so that the motion becomes unstable. Hence $\pi - \phi_s$ is an extreme elongation corresponding to a stable motion. The corresponding curve in the $(\phi/\Omega_s, \phi)$ space or in the (W, ϕ) space is called the separatrix and the area delimited by this curve is called the RF bucket. The equation of the separatrix is:

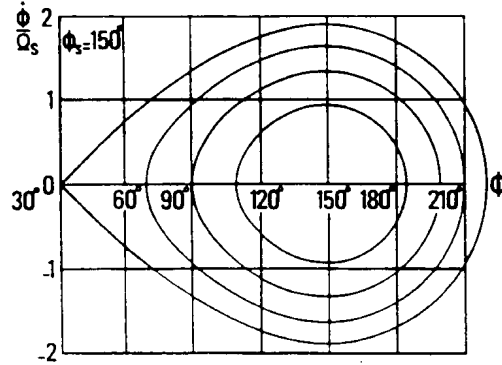

Fig. 6 Stable phase space trajectories

$$\frac{\dot{\phi}^2}{2} - \frac{\Omega_s^2}{\cos \phi_s} (\cos \phi + \phi \sin \phi_s) = -\frac{\Omega_s^2}{\cos \phi_s} [\cos(\pi - \phi_s) + (\pi - \phi_s) \sin \phi_s]$$

The second value ϕ_m , for which $\dot{\phi} = 0$, is such that:

$$\cos \phi_m + \phi_m \sin \phi_s = \cos(\pi - \phi_s) + (\pi - \phi_s) \sin \phi_s$$

From the equation of motion it is also seen that $\dot{\phi}$ reaches an extremum when $\ddot{\phi} = 0$ corresponding to $\phi = \phi_s$. Introducing this value in the equation of the separatrix gives the maximum stable values of $\dot{\phi}$ and W :

$$\dot{\phi}_{max}^2 = 2\Omega_s^2 [2 - (\pi - 2\phi_s) \text{tg} \phi_s]$$

$$W_{max}^2 = 2e\hat{V} [2 \cos \phi_s - (\pi - 2\phi_s) \sin \phi_s] \frac{2\pi p_s R_s}{h\eta\omega_s}$$

or

$$\left(\frac{\Delta E}{E_s} \right)_{max} = \pm \beta \left\{ \frac{e\hat{V}}{\pi h \eta E_s} G(\phi_s) \right\}^{1/2}$$

This last expression is called the RF acceptance. The function $G(\phi_s)$ is given by:

$$G(\phi_s) = [2 \cos \phi_s - (\pi - 2\phi_s) \sin \phi_s]$$

and varies from ± 2 to 0 when $\sin \phi_s$ varies from 0 to 1.

The RF acceptance plays an important role when designing a machine, since it determines the capture efficiency at injection and the lifetime of stored beams. Outside the stable region plots of the trajectories (Fig. 7) show that particles get out of synchronism, their phase sliding along. Moreover the energy is continuously changing which means that the particles may get lost.

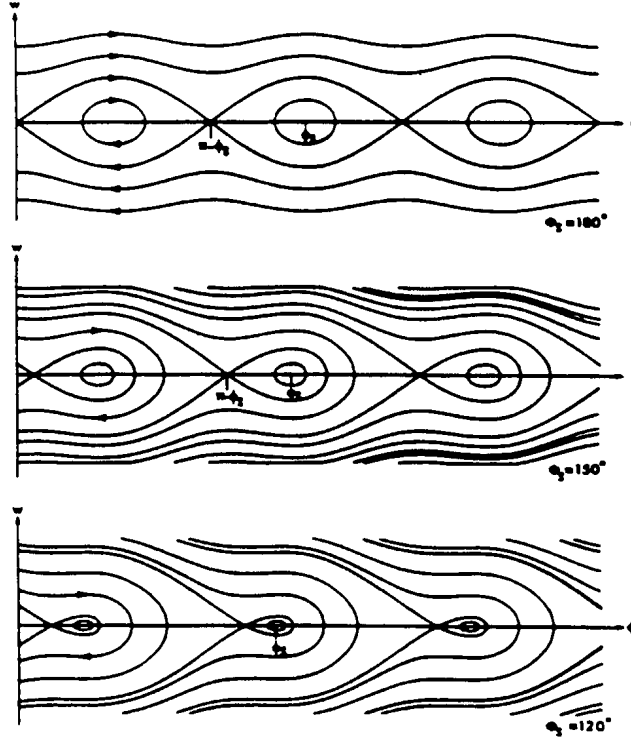

Fig. 7 Phase space trajectories for different ϕ_s

For any invariant of the motion there exists a relation between the maximum energy and the maximum phase deviations. However it is in general difficult to derive it analytically unless special assumptions are made. For instance in the case of small amplitude oscillations the invariant becomes simply:

$$\frac{\dot{\phi}^2}{2} + \Omega_s^2 \frac{\Delta\phi^2}{2} = cte$$

which leads to:

$$\Delta\phi_{max} = \frac{h\eta E_s}{p_s R_s \Omega_s} \left(\frac{\Delta E}{E_s} \right)_{max}$$

since $\dot{\phi}_{max}$ is directly related to ΔE_{max} .

In the case of ultra relativistic electrons this reduces to:

$$\Delta\phi_{max} = \frac{\alpha h}{Q_s} \left(\frac{\Delta E}{E_s} \right)_{max}$$

3.5 Potential energy function

The synchrotron motion is produced by a force field which can be derived from a scalar potential:

$$\frac{d^2\phi}{dt^2} = F(\phi)$$

$$F(\phi) = -\frac{\partial U}{\partial \phi}$$

$$U(\phi) = -\int F(\phi)d\phi = -\frac{\Omega_s^2}{\cos\phi_s}(\cos\phi + \phi \sin\phi_s)$$

The sum of the potential energy and the kinetic energy is a constant (the total energy):

$$\frac{\dot{\phi}^2}{2} + U(\phi) = U_0$$

The RF voltage as well as the corresponding potential energy function are shown on Fig. 8. The shape of the latter corresponds to the sum of a linear function and a sinusoidal one. An oscillation can only take place if the particle is trapped in the potential well which means that the total energy cannot exceed a certain value (dotted line) otherwise the particle will slide along the curve. Hence the maxima of the curve correspond to unstable equilibrium for the synchrotron motion.

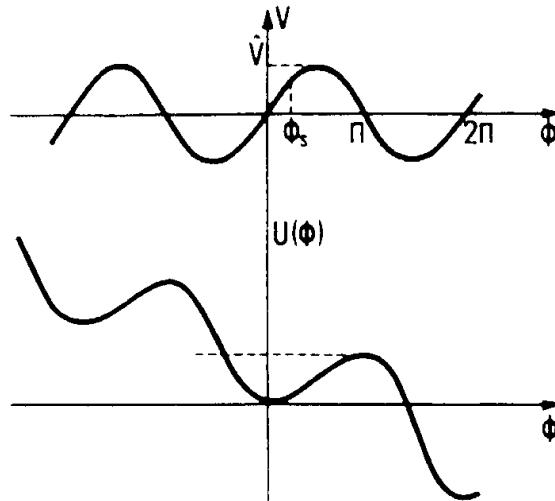

Fig. 8 Accelerating voltage and potential energy function

4. ADIABATIC DAMPING OF SYNCHROTRON OSCILLATIONS

So far one has assumed that the parameters R_s , p_s , ω_s and \hat{V} did not change appreciably at least over a time scale of one synchrotron period. However in a synchrotron these parameters will vary over a large range, even slowly, during an acceleration cycle. Then one needs to study the long term evolution of the motion under adiabatic changes of these parameters. This is possible with the help of the Boltzman-Ehrenfest adiabatic theorem which states that, if p and q are canonically conjugate variables of an oscillatory system with slowly changing parameters, then the action integral is constant:

$$I = \oint pdq = cte$$

the integral being taken over one period of oscillation. It has been already mentioned that the variables W and ϕ , describing the synchrotron motion, were canonically conjugate. Hence applying the theorem leads to:

$$I = \oint W d\phi = cte$$

Consider the corresponding Hamiltonian of the motion and let's expand it to second order approximation to take care of small amplitude oscillations only

$$H(W, \phi, t) \cong -\frac{e\hat{V}}{2} \cos\phi_s \Delta\phi^2 - \frac{1}{4\pi} \frac{h\eta\omega_s}{R_s p_s} W^2$$

leading to harmonic solutions for the motions:

$$W = \hat{W} \cos\Omega_s t$$

$$\Delta\phi = \Delta\hat{\phi} \sin\Omega_s t$$

Since:

$$\frac{d\phi}{dt} = \frac{\partial H}{\partial W} = -\frac{1}{2\pi} \frac{h\eta\omega_s}{R_s p_s} W$$

one gets the action integral:

$$I = \oint W \frac{d\phi}{dt} dt$$

$$I = -\frac{1}{2\pi} \frac{h\eta\omega_s}{R_s p_s} \oint W^2 dt$$

$$I = -\frac{1}{2} \frac{h\eta\omega_s}{R_s p_s} \frac{\hat{W}^2}{\Omega_s} = cte$$

where \hat{W} is the amplitude of the energy oscillation related to the amplitude of the phase displacement through:

$$\hat{W} = \frac{2\pi R_s p_s \Omega_s}{h\eta\omega_s} \Delta\hat{\phi}$$

So one gets:

$$\Delta\hat{\phi} \propto \left\{ \frac{\eta}{E_s R_s^2 \hat{V} \cos\phi_s} \right\}^{1/4}$$

Keeping all parameters constant except the energy which is ramping, the formula shows that the phase excursion $\Delta\hat{\phi}$ is reduced as the one-fourth power of the energy.

It appears also that the product $\hat{W} \cdot \Delta\hat{\phi}$ is invariant which means that the phase space area is invariant and Liouville's theorem still holds in adiabatic conditions. The phase space area is not damped, only the shape of the ellipse is modified.

From the previous treatment one also gets:

$$\Delta \hat{E} \propto \omega_s \left\{ \frac{E_s R_s^2 \hat{V} \cos \phi_s}{\eta} \right\}^{1/4}$$

$$\Delta \hat{R} \propto \frac{\alpha}{\omega_s} \left\{ \frac{\hat{V} \cos \phi_s}{E_s^3 R_s^2 \eta} \right\}^{1/4}$$

the last formula representing the orbit excursion due to the momentum deviation during the ramping.

The adiabatic damping can also be treated without the Hamiltonian formulation. Remembering the general equation for synchrotron oscillations limited to small phase deviations:

$$\frac{d}{dt} \left[\frac{E_s}{h\alpha\omega_s^2} \frac{d\phi}{dt} \right] + \frac{e\hat{V} \cos \phi_s}{2\pi} \Delta\phi = 0 \quad (\text{for the case } \beta = 1)$$

one can write it in the form:

$$\frac{E_s}{h\alpha\omega_s^2} \frac{d^2\phi}{dt^2} + \frac{\dot{E}_s}{h\alpha\omega_s^2} \frac{d\phi}{dt} + \frac{e\hat{V} \cos \phi_s}{2\pi} \Delta\phi = 0$$

or

$$\frac{d^2\phi}{dt^2} + \frac{\dot{E}_s}{E_s} \frac{d\phi}{dt} + \Omega_s^2 \Delta\phi = 0$$

where the second term represents a damping term. From the definition of Ω_s one has:

$$\frac{\dot{E}_s}{E_s} = -2 \frac{\dot{\Omega}_s}{\Omega_s} .$$

To integrate this equation the procedure consists of choosing a solution similar to the one obtained without the additional damping term:

$$\Delta\phi = \Delta\hat{\phi} \sin \left(\int^t \Omega_s(\tau) d\tau + cte \right) = \Delta\hat{\phi}(t) \sin \psi(t)$$

and assuming $\Delta\hat{\phi}$ and $\dot{\Omega}_s$ are small first-order quantities (adiabatic limit). Putting this solution into the differential equation and neglecting all second-order terms gives:

$$\left[2\Delta\hat{\phi}\dot{\Omega}_s - \Delta\hat{\phi}\dot{\Omega}_s \right] \cos \psi(t) = 0$$

$$2 \frac{\Delta\hat{\phi}}{\Delta\hat{\phi}} - \frac{\dot{\Omega}_s}{\Omega_s} = 0$$

and integrating leads to:

$$\Delta\hat{\phi} \propto \Omega_s^{1/2}$$

$$\Delta\hat{\phi} \propto E_s^{-1/4}$$

result which is similar to the one obtained previously.

5. TRAPPING, MATCHING, ACCUMULATING AND ACCELERATING PROCESSES

Whether the circular accelerator is used as a synchrotron or a storage ring, the operation of the RF will be quite different.

5.1 Acceleration into a synchrotron

In that case, as mentioned before, the accelerating cycle is fast. Only a single injected pulse is accelerated. This injected pulse must be trapped in the RF buckets with a maximum efficiency which means that the RF acceptance hence the RF voltage has to be large enough, compatible with the energy spread of the transferred pulse. The RF frequency at injection must be such that it will fit with the bending field and the injection orbit. The synchronous phase is then set automatically at $\phi_s = 0$ or π which means no average acceleration.

Matching means that the RF frequency and the RF voltage are adjusted such that the phase-space trajectories are homothetic to the contour of the injected bunch. If this was not the case the shape of the bunch would change during the synchrotron period and, for instance, the bunch length could become short giving rise to instabilities. Matching also requires careful adjustment of the injector to make it compatible with the possibilities of the synchrotron.

To start the acceleration it is necessary to move the synchronous phase so that the synchronous particle gets energy at each revolution from the RF cavities. This can be done by offsetting the magnetic field followed by a change of the RF frequency.

The synchronous particle is the one for which the revolution frequency satisfies

$$\omega_s = \frac{\omega_{RF}}{h}$$

and it follows a closed orbit for which the physical radius satisfies

$$\omega(B, R_s) = \omega_s$$

As mentioned previously the rate of change of momentum for the synchronous particle is:

$$\frac{dp_s}{dt} = eR_s \langle \dot{B} \rangle$$

Hence the RF frequency must follow:

$$\frac{f_{RF}(t)}{h} = \frac{1}{2\pi R_s} \beta c = \frac{1}{2\pi} \frac{e}{m(t)} \langle B(t) \rangle$$

$$\frac{f_{RF}(t)}{h} = \frac{1}{2\pi} \frac{ec^2}{E_s(t)} \frac{\rho}{R_s} B(t)$$

Since

$$E_s^2 = (m_0 c^2)^2 + p_s^2 c^2$$

the RF frequency must follow the magnetic field variation with the following law:

$$\frac{f_{RF}(t)}{h} = \frac{c}{2\pi R_s} \left[\frac{B(t)^2}{(m_0 c^2 / e c \rho)^2 + B(t)^2} \right]^{1/2}$$

This asymptotically tends towards $f_r = c/2\pi R_s$ when B is getting large compared to $m_0 c^2 / e c \rho$ corresponding to $v \rightarrow c$ ($pc \gg m_0 c^2$).

In practice the magnetic field can either follow an approximately linear law or a sinusoidal one

$$B(t) = \frac{\hat{B}}{2}(1 - \cos \omega t) = \hat{B} \sin^2 \frac{\omega}{2} t .$$

In the case of an electron synchrotron it is not necessary to vary the RF frequency because the particle velocity is very close to c and does not change with energy. However the electron loses energy in each revolution due to synchrotron radiation. Hence the synchronous particle is the one which arrives at the right phase ϕ_s to compensate for both this energy lost and the field variation.

5.2 Accumulation into a storage ring

A storage ring is roughly a synchrotron operating at fixed energy. In some cases a very slow ramping can be done if the operating fixed energy differs from the injection one.

5.2.1 Electron storage rings

As for the electron synchrotron the energy lost has to be compensated. If the energy lost per turn is δE , then the synchronous phase is such that:

$$\delta E = e \hat{V} \sin \phi_s$$

which means that ϕ_s will depend on the peak RF voltage \hat{V} . Moreover the energy lost per turn is a strong function of the operating energy:

$$\delta E_{[keV]} = 88.4 \frac{E_{[GeV]}^4}{\rho_{[m]}}$$

If the storage ring operates between two energies, the maximum voltage will be determined by the upper energy and for the reason of beam lifetime due to particle diffusion through the separatrix, $\sin \phi_s \leq 0.7$. If one keeps at injection the same voltage as required at the highest energy then $\sin \phi_s$ at injection can be very small leading to a large bucket acceptance.

Since the particle motion is damped around the synchronous particle the bunch length and energy spread become quite small leaving most of the bucket empty for a new injected pulse which will damp also and so on. This is the simple way of accumulating particles in an electron storage ring where Liouville's theorem does not hold any more due to non-conservative forces.

However accumulation of very high circulating currents in an electron storage ring may lead to typical instabilities related to coherent motion in the transverse phase space. Hence it is often desirable to keep Q constant when ramping the energy even slowly. Of course this will lower quite a lot the peak voltage required at injection and make the bucket smaller. Then the injector and the transport system to the storage ring have to be matched to the injection conditions.

5.2.2 Proton storage rings

Here the accumulation process is often called "stacking". It consists of trapping particles into buckets on a special orbit, called the injection orbit, close to the injection septum. Then the buckets are accelerated towards an inner orbit in the vacuum chamber. Such an acceleration is done with constant bending field, just by changing the RF frequency. Finally the RF voltage is switched off so that the particles will debunch. Hence, the RF is switched on again at the injection RF frequency to take care of new injected particles and the new buckets are accelerated to another stacking orbit close to the previous one. In doing so the previous injected particles will be slightly disturbed. The energy difference ΔE_s between RF switch off of successive pulses is normally chosen to be approximately the bunch area divided by 2π which corresponds to the energy width of an ideally debunched pulse. In this process the stacking efficiency suffers from the non-linearity of the motion in the neighbourhood of the separatrix.

BIBLIOGRAPHY

M. Stanley Livingston, John P. Blewett. Particle Accelerators
Mc Graw-Hill, Book Company, INC. N.Y 1962

E. Persico, E. Ferrari, S.E. Segre. Principles of Particle Accelerators, W.A. Benjamin, INC.
N.Y 1968

H. Bruck, Accélérateurs circulaires de particules, Presses Universitaires de France, Paris 1966

B.W. Montague, RF acceleration, Proceedings of the first Course of the International School of Particle Accelerators, ERICE – CERN 77–13, 19 July 1977

M. Sands, The physics of electron storage rings, SLAC report 121 (1970). Also in Proceedings of the International School of Physics, B. Touschek, Editor (Enrico Fermi) Varenna 1969, Academic Press, N.Y. 1971