

ОБЪЕДИНЕННЫЙ
ИНСТИТУТ
ЯДЕРНЫХ
ИССЛЕДОВАНИЙ

Дубна

E13-98-197

N.G.Anishchenko, V.D.Bartenev, N.A.Blinov, N.S.Borisov,
V.M.Drobin, G.Durand*, S.A.Ivashkevich, B.K.Kuryatnikov,
F.Lehar*, S.V.Mironov, V.D.Moroz, A.B.Neganov,
N.M.Piskunov, Yu.V.Romanov, Yu.I.Tyatyushkin,
Yu.A.Usov, A.N.Fedorov, G.P.Tsvineva, Yu.A.Shishov

SUPERCONDUCTING POLARIZING MAGNET
FOR A MOVABLE POLARIZED TARGET

Submitted to the 13 International Symposium on High Energy Spin
Physics, September 8—12, Protvino, Russia

*DAPNIA, CEA/Saclay, 91191 Gif-sur-Yvette Cedex, France



SCAN-9901020

CERN LIBRARIES, GENEVA

SW9907

1998

1. INTRODUCTION

The movable polarized target (MPT) in Dubna was reconstructed from the previous proton polarized target (PPT) built in 1985-1988 at Saclay by ANL and Saclay experts [2] for purposes of the E-704 Fermilab experiment. This PPT has been used at FNAL during 1988-1990 [3]. It has been transported to JINR (Dubna) in 1994 and reconstructed before the end of the year as the movable target, easily transportable from one beam line to another. Its reconstruction and improvement [4] were supported by INTAS grant 93-3315.

The international experimental program with MPT on the polarized neutron beam at the Dubna synchrotron was accepted in early 1994. The first experiment in physics was carried out in February-March 1995 [5]. Just after the measurements, the original polarizing magnet was dispatched to Mainz (Germany). Therefore, a new magnet was needed to be manufactured. Its construction was supported by INTAS in 1996.

2. DESIGN AND BASIC PARAMETERS OF THE MAGNET

The superconducting polarizing magnet (see Fig. 1 and Tab. 1) contains a main solenoidal winding 1 (558 mm in long, 206 and 144 mm in outside and inside diameters, respectively) as well as compensating 6 and correcting 7 windings at its ends. Multifilament NbTi wires are wound on welded frame 2 of steel 1X18H10T consisting of a pipe and flanges. Frame 2 with an outside vessel and other parts forms welded helium vessel 4, which is fixed into vacuum casing 5 with the help of glasstextolite support cone 8. The thermal insulation of the helium vessel is provided with cooled helium vapours by copper screens 9 and multilayer screens 10 made of metal-coated mylar. The combined current leads and tubes of helium input and output are in the vertical vessel. The insulating vacuum is formed with the aid of turbomolecular and fore pumps. Power supply and the protection of the main and compensating windings are by a stabilized power supply source (200 A, 10 V) made at ANL, USA. The correcting windings were independently supplied from two stabilized sources (25 A, 5 V).

Among the basic technical requirements on the magnet, note the following: the induction of a magnetic field in the centre of the magnet with a maximum working

current of 186 A should be 6.7 T, the uniformity of the field in a "warm" working volume (200 mm long, 30 mm in diameter) no worse than 10^{-4} .

It was also necessary to ensure a complete geometric compatibility of the new magnet cryostat with the existing design of the remaining MTP parts.

3. DESIGN AND TECHNOLOGY OF THE WINDING

The winding (see Fig. 1) is mounted on frame 2 (pipe \varnothing 143.5 mm) with case electric glasstextolite insulation. Two layers 0.2 mm in thickness of such insulation were applied on the cylindrical part with epoxy gluing and subsequent turning processing. The inner part of flanges 2 was insulated with dismountable half-disks 3 of glasstextolite 6.5 mm thickness. The half-disks 3 have the grooves for going the superconductor out of the internal sections of the winding and stacking the contact connections of the superconductor.

The winding made at Saclay was done by a uniform piece of wire with a small spread in diameter through the whole length. In contrast to this, individual pieces of a wire of different length (see Tab. 2) might be used for the winding of the new magnet. Additional winding difficulties were due to a small (± 0.015 mm) difference in the diameter of the individual wire pieces. The presence of six soldered wire connections complicated the performance of the electroinsulating design of the magnet. These and other differences of initial conditions of manufacturing the new magnet resulted in some features of its design and winding technology.

The main winding (31 layers with $511 \div 514$ coils each) consists of 6 concentric sections. When winding, glasstextolite spacers 0.2 mm thickness are used to keep layer cylindricity (see Tab. 2).

Two sections of compensating winding 6 in Fig. 1 are wound up (also by wire \varnothing 1 mm) sequentially with the basic section and over it. There are two correcting NbTi windings 7 of a wire \varnothing 0.75 mm over the compensating windings.

During winding, the wire was moistened in epoxy resin compound of cold curing (trade mark: Scotchcast 252 3M, France); polymerization lasts 20 hours at 75°C . The weight ratio of the resin to the hardener was 1:1. To apply the compound, the wire was passed through a plastic bath. The levelling spacers were pasted with the same compound. During winding, the edge coils on the side of

both flanges in each layer of the winding were fastened with the help of two-component polyester putty. The time of putty hardening was ~ 10 minutes, polymerization lasted at room temperature for ~ 40 minutes, then it was possible to smear the next layer.

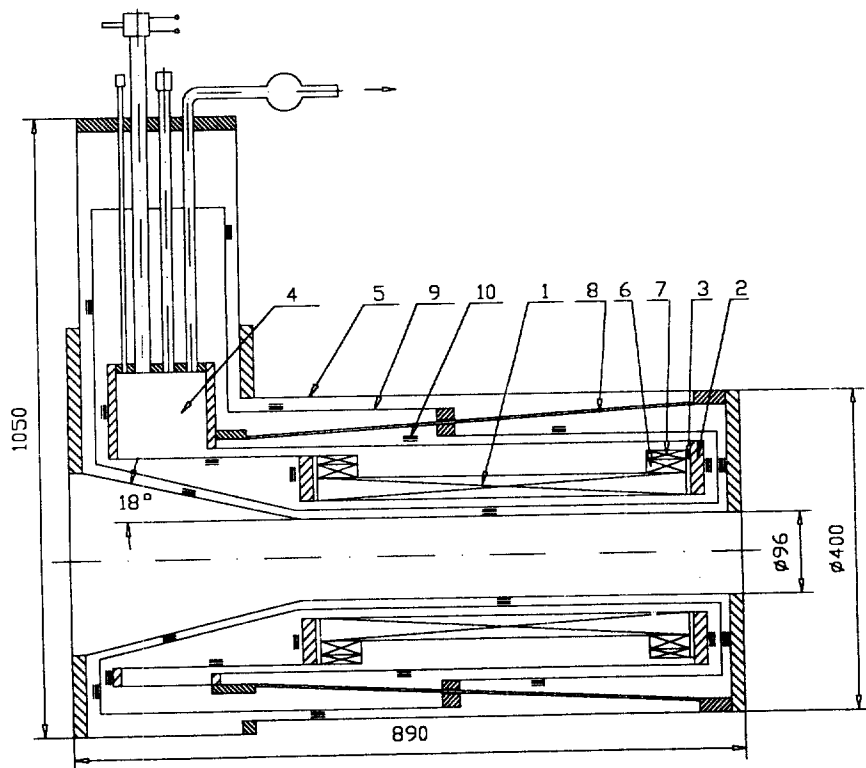

Fig. 1. Polarizing magnet MPT.

- 1 - main winding; 2 - frame of stainless steel; 3 - insulating half-disks;
- 4 - helium vessel; 5 - vacuum vessel; 6 - compensating windings;
- 7 - correcting windings; 8 - glasstextolite support cone;
- 9 - copper radiation screen; 10 - multilayer superinsulation.

Table 1. Basic parameters of the polarizing magnet

Item	Unit	Value
Cryostat (vacuum casing):		
- length	mm	890
- diameter: inside "warm"	mm	96
outside	mm	400
Solenoid:		
- inductance (main and two compensating windings)	H	13
- winding length	mm	558
- diameter: inside	mm	144
outside (basic winding)	mm	206
outside (frame flanges)	mm	268
- number of sections of the basic winding		6
- calculated maximum working current, I_0	A	186
- maximum reached working current	A	160
- current density in wire (with I_0)	A/cm ²	2.4×10^4
- critical current density with 4.2 K in a field of 7 T, no less	A/cm ²	4.5×10^4
- field the centre of the aperture (with I_0)	T	6.7
- maximum field (with I_0 ; $z = \pm 230$ mm)	T	6.9
- reached field in the aperture centre (with 160 A)	T	~5.8
- currents of the correcting windings	A	0±10
- mass cooled to 4.2 K	kg	120
- number of wire solderings		6
Compensating winding (in two sections):		
- winding length of each section (40 coils)	mm	43
- winding thickness (30 layers)	mm	27
- outside diameter of the winding	mm	254
- number of coils in the winding of each section		1200
Correcting winding (in two sections) :		
- winding thickness (19 layers)	mm	7.0
- outside diameter of the winding	mm	268
- number of coils in winding of each section		768
Wire (NbTi in a copper matrix) :		
Main and compensating windings :		
- diameter (in insulation)	mm	1.06±1.09
- number of filaments in a wire of 3 and 4 sections		2970
- number of filaments in a wire of 1,2,5 and 6 sections		60
- factor of filling with superconductor		0.405±0.51
Correcting windings :		
- diameter (in insulation)	mm	0.75

Table 2. The characteristic of $\varnothing 1$ mm superconductor in the magnet sections

Number of section, numbers of winding layers	Wire length in section, m	Wire characteristic :			Minimum critical current with 7 T. A
		Diameter in insulation, mm	Coefficient of filling with superconductor	Number of NbTi filaments	
I (inside), layers (1÷6)	1461	1.07	0.46	60	390
II (7÷9)	768	1.06	0.465	60	440
glasstextolite spacer 0.2 mm in thickness					
III (10÷17)	2173	1.09	0.405	2970	360
IV (18÷21)	1159	1.09	0.41	2970	380
V (22÷26)	1520	1.08	0.51	60	410
glasstextolite spacer 0.2 mm in thickness					
VI (27÷31)	1915	1.08	0.5	60	410
Total length 8996 m					

The integrity of the conductor varnish coat was continuously checked. This was carried out with the help of the device containing an original sliding brush contact made of a NbTi multifilament wire from which end stabilizing copper was stripped. The conductor coat was made by a PE-939 polyester varnish hot curing under industrial conditions. The wire strain with winding the magnet was $10 \div 12$ kg and could be adjusted by an electric motor operating in a brake mode and located on one shaft with a feed coil. During the winding, layer-by-layer cylindricity was periodically controlled by measuring the winding diameter in six cross sections along the magnet axis by a micrometric device with an accuracy of no worse than 0.01 mm. The wire of an overlying layer was placed in the screw flute of an underlaying one. This leads to the cross the wires of these layers on each coil. Thus, a wave of crossing is formed on the layer surface. It should be along the winding axis. The waves were evenly distributed along the azimuth of the winding cross section. In general, the layer-by-layer noncylindricity of the basic winding cross sections did not exceed 0.8 mm.

Before soldering, the soldered contacts of wires 20 cm long (POS-61 solder with $t_{\text{melt.}} = 190$ °C) were bandaged by a flattened copper wire 1mm in width and 0.2 mm in thickness. After soldering they were insulated with a PTFE small tube $\varnothing 3$ mm. The calculated nonuniformity of the field in the working volume due to a partial nonbifilarity of the nearing the wires place of contact is $4 \div 5$ times lower than that specified in technical requirements to a magnet.

The temperature of adiabatic heating the hottest point in case of the transition of the winding to a normal state and the evacuation of stored energy for an external damping resistance of 2 Ohms was calculated. The most dangerous regime was considered : the origin of a normal zone at the point of wire soldering; the conditions of heating are adiabatic; the current at the moment of transition is 200 A. The calculation made by the technique suggested in [6] has shown that the heating does not exceed 100 K.

The cylindrical part of the magnet frame was insulated with two layers of fiberglass (see above) with a 180° overlapping. During winding, the electrical strength of the case insulation was periodically checked by the direct voltage of 1000 V. The interlayer one, between individual sections before contact soldering, was checked by the voltage of 200 V for 5 minutes. The intercoil insulation was tested by the voltage of 1000 V for 5 minutes on a special model winding of the wire used.

4. CRYOSTAT

The magnetic properties of 1X18H10T stainless steel, which were displayed after some technological operations during manufacturing the cryostat, have considerably complicated the situation and have not allowed a higher uniformity of the desired field. The magnetic field measurements of the completed magnet were carried out in an auxiliary vertical stainless-steel cryostat. The influence of the massive bottom, of some parts after turning procedure, as well as of the welded seams on the field uniformity in the magnet working volume was observed. This influence can be estimated by a maximum size of the order of $1 \div 2$ Gs as radial and axial components of the field at some points of the working volume. After an additional check of the magnetic properties of all the parts of the working cryostat, some of them were replaced by nonmagnetic ones.

During the manufacture and assembly of the cryostat after conducting each of the welding operations, the trainings of the places of welding in liquid nitrogen were carried out. Then the subsequent vacuum tests of the helium vessel, vacuum casing and individual units also were carried out at 300 K using a helium leak detector.

5. CURRENT LEADS

A combined current lead, cooled by return helium for the main (200 A) and two correcting windings (2×10 A) were placed in the stainless steel pipe \varnothing 40 mm, whereas the current-carrying elements are copper foils. The heat leaks to liquid helium via the current leads, were no more than 0.8 Wt for a current-carrying pair to the main winding of the magnet at 200 A and a flow rate of cooling gaseous helium ~ 0.8 nm³/h; 0.15 Wt for two current-carrying pairs to the correcting windings at currents of 10 A and a flow rate of ~ 0.15 nm³/h. Thus, the copper temperature of the cold end of the current lead was no more than 4.35 K.

6. MAGNETIC MEASUREMENT SYSTEM

In order to determine the magnetic field topography in the warm working solenoid volume, the system used consists of:

- 1) the magnetometer MN-18M using the nuclear magnetic resonance (NMR),
- 2) the NMR frequency meter- F3-63.
- 3) devices for moving the gauge magnetometer in steps of 10 mm along the axis and in steps of 5 mm in the radius direction. The angular movement of the gauge occurred in step of 45 degrees.

The basic characteristics of the magnetometer MN-18M were:

- 1) the measured fields ranged from 1.7 to 6.5 T and were measured using two replaceable heads of the gauge,
- 2) errors of the magnetic field induction measurement turned below 10^{-5} ,
- 3) the volume of an active part containing polarizable protons was approximately 3.5 mm³; NMR on protons was applied,
- 4) the overall dimensions of the gauge with a replaceable head were $9 \times 17 \times 35$ mm,
- 5) the length of the cable, connecting the gauge with the other part of the magnetometer was about 15 m,
- 6) a search for NMR, adjustment to it and other adjustments are kinds of tuning were automatic.

The described magnetometer has been developed at the Laboratory of Nuclear Problems, JINR [7,8].

7. RESULTS OF TESTS

Repeated long time-frame tests of the polarizing magnet at currents of 80 and 120 A were successfully undertaken. The current of 160 A was applied for a short time period only. The emergency protection of the magnet winding was tested as the superconductor passed to a normal state. The local and remote control of the power supply source for the basic winding was used.

The magnetic field topography inside the warm working magnet volume was repeatedly measured. Fig. 2 shows magnetic measurement results for one of the current modes of the magnet winding power supply. The correcting winding "1" is the first one along the beam path. The measurements were carried out over the length L from the middle of the magnet, along its axis ($R=0$ curves). Other measurements were performed at $R = 15$ mm in horizontal steps of 10 mm and in an angle step of 45° . The field uniformity of 4.6×10^{-4} within the working volume was achieved. This uniformity in the second, downstream half of the working volume, was better : 7.8×10^{-5} .

The magnet operated reliably in the July 1997 physics experiment in which polarized neutron beam together with MPT was again used. The longitudinal MPT polarization, averaged over the target volume was 73%. During the whole run, the magnet field uniformity along the working volume axis was better than 5.7×10^{-4} . The used current mode was: $I_{\text{main}} = 75.2$ A; $I_{\text{cor.1}} = 1.8$ A; $I_{\text{cor.2}} = 5$ A).

After the run, an additional warm correction was applied by a small steel ring ($\varnothing_{\text{mid.}} 95$ mm; a section of (0.35×3) mm²) and by a three-layer coil (102 coils; (1×8) mm²; $\varnothing_{\text{mid.}} 95$ mm; current of 0.211 A). The field uniformity increased by the factor 1.7 over the warm working volume. It reached final values of 2.67×10^{-4} and to 4.4×10^{-5} on the axis (see Fig. 3). Therefore, the expediency and efficiency of an additional warm correction was experimentally confirmed. The correcting elements can be installed inside a narrow gap between the target and the internal solenoid cryostat wall. Mobile coils, individual steel rings or a punched ferromagnetic pipe can be used for these purposes.

The future experiments will provide an opportunity to increase the uniformity of the magnetic field in the working volume of the target and to reach better value than 10^{-4} .

8. CONCLUSION

The constructed polarizing magnet for MPT allow to continue the program in physics and to plan future experiments at the LHE synchrotron. Different magnet parameters may be improved as discussed above. This will increase the MPT polarization and spare the machine time.

ACKNOWLEDGEMENTS

We thank A.M.Baldin, A.D.Kovalenko, A.I.Malakhov, B.Peyaud, V.S.Rumyantsev, N.A.Rusakovich, A.N.Sissakyan for their support of this work. We express our gratitude to G.P.Nikolaevsky, S.A.Dolgii and A.Yu.Starikov - for their help in carrying out the magnetic measurements. This work was supported twice by INTAS grant 93-3315.

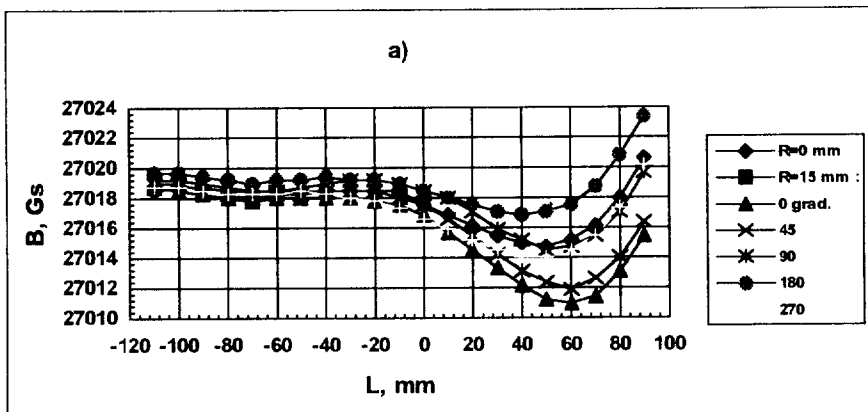

BEAM \leftarrow

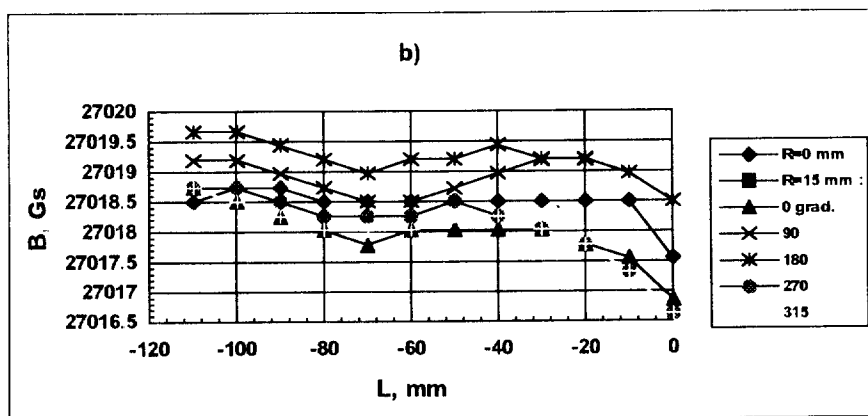
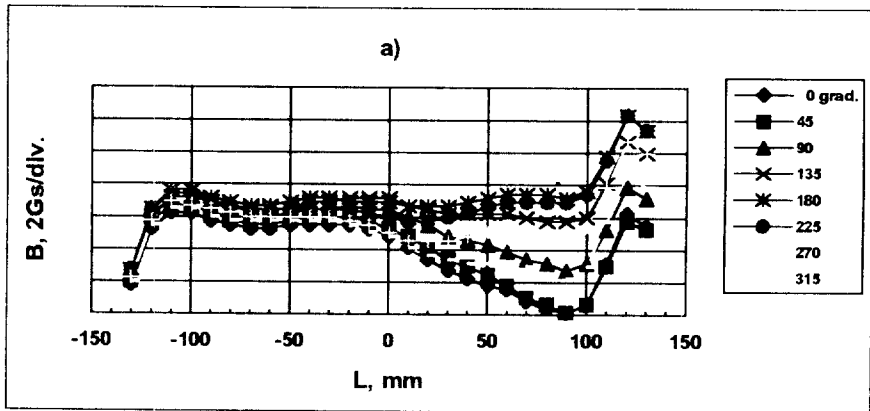

Fig. 2. Results of measurements of the magnetic field in the working volume of the target ($I_{\text{main}} = 74.42$ A; $I_{\text{cor.1}} = 2.60$ A; $I_{\text{cor.2}} = 4.64$ A).

a) $L = -110$ mm \div $+90$ mm; $[B_{\text{max}}(180^\circ) - B_{\text{min}}(0^\circ)]/B_0 = 4.6 \times 10^{-4}$.

b) $L = -110$ mm \div 0 mm; $[B_{\text{max}}(180^\circ) - B_{\text{min}}(315^\circ)]/B_0 = 7.8 \times 10^{-5}$.



BEAM

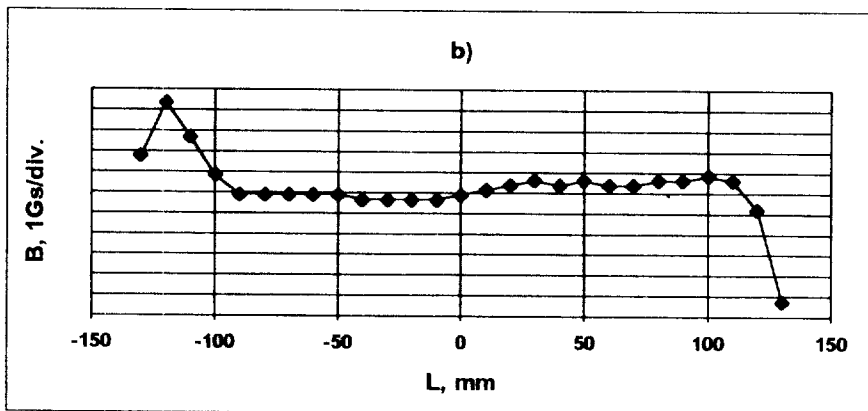

Fig. 3. Results of measurements of the magnetic field in the working volume of the target using an additional "warm" correction

($I_{\text{main}} = 74.4 \text{ A}$; $I_{\text{cor.1}} = 2.60 \text{ A}$; $I_{\text{cor.2}} = 4.65 \text{ A}$).

a) $R = 15 \text{ mm}$; $L = -100 \text{ mm} \div +100 \text{ mm}$; $[B_{\text{max}} - B_{\text{min}}]/B_0 = 2.67 \times 10^{-4}$.

b) $R = 0$; $L = -100 \text{ mm} \div +100 \text{ mm}$; $[B_{\text{max}} - B_{\text{min}}]/B_0 = 4.4 \times 10^{-5}$.

REFERENCES

- [1] N.A.Bazhanov et al. Nucl. Instrum. Methods A. 372 (1996) p. 349-351.
- [2] P.Chaumette, J.Deregel, H.Desportes et al. Proceedings of International Workshop on Polarized Sources and Targets, Editors : S.Jaccard and S.Mango. Montana (Switzerland), Jan. 13-17,1986, p. 767-771 and Helvetica Physica Acta Vol. 59 (1986), p. 786-787.
- [3] P.Chaumette, J.Deregel, H.Desportes et al. First use of the Polarized Target Facility at Fermilab, 9 th International Symposium on High Energy Spin Physics, Bonn (Germany), Sept. 6-15, 1990, Proceedings edited by W.Meyer, E. Steffens and W.Thiel, Springer Verlag (1991), Vol.2, p. 320-324.
- [4] N.Anishchenko, N.Bazhanov, B.Benda et al. A New Movable Polarized Target at Dubna, 11th Intern. Symposium on High Energy Spin Physics, Bloomington, Indiana, USA, Sept. 1994. AIP Conference Proceedings 343, Editors K.Heller and S.Smith, AIP Press, Woodbury N.Y., p. 572-575.
- [5] B.P.Adiasevich, V.G.Antonenko, S.A.Averichev et al. Measurement of the Total Cross Section Difference D_{sL} in np Transmission at 1.19, 2.49 and 3.65 GeV. Zeitschrift fur Physics C 71 (1996), p.65-74
- [6] M.S.McAshak. MIITS Integrals for Copper and for Nb-46,5 Wt of % Ti. Preprint SSC, N 468, 1988.
- [7] S.A.Ivashkevich, Ja.Lagish. Automatic Nuclear Magnetometer with a Resonance on Protons up to 6 T, The communication JINR, P13-90-400, Dubna, 1990.
- [8] S.A.Ivashkevich. The Circuit for Fast Automatic Search of a Resonance and Set-up with it in Nuclear Magnetometer. The communication JINR. D13-93-222, Dubna, 1993.

Received by Publishing Department
on July 6, 1998.

Сверхпроводящий полярирующий магнит
для подвижной поляризованной мишени

В ОИЯИ (Дубна) создан сверхпроводящий полярирующий магнит для подвижной поляризованной мишени (ППМ) с рабочим объемом 200 мм длиной и 30 мм в диаметре [1]. Магнит обеспечивает поляризующее магнитное поле до 6 Т при однородности $4,5 \times 10^{-4}$ в рабочем объеме мишени, а также содержит основную соленоидальную обмотку длиной 558 мм с диаметрами 206 и 144 мм и расположенные по ее концам компенсирующие и корректирующие обмотки. Все обмотки выполнены из NbTi провода, пропитаны эпоксидным компаундом и помещены в горизонтальный криостат, диаметр «теплой» апертуры которого 96 мм.

Описаны конструкция и технология намотки магнита. Приведены результаты измерений карты магнитного поля с использованием ЯМР-магнетометра. Моделью данного магнита послужил аналогичный магнит, созданный в ядерном исследовательском центре Saclay (Франция). Установка с ППМ смонтирована на пучке поляризованных нейтронов, образующихся при развале поляризованных дейтронов, выведенных из синхрофазотрона ЛВЭ ОИЯИ (Дубна).

Работа выполнена в Лаборатории высоких энергий и Лаборатории ядерных проблем ОИЯИ.

Препринт Объединенного института ядерных исследований. Дубна, 1998

Superconducting Polarizing Magnet
for a Movable Polarized Target

The superconducting polarizing magnet was constructed for the JINR (Dubna) movable polarized target (MPT) with working volume 200 mm long and 30 mm in diameter [1]. The magnet provides a polarizing magnetic field up to 6 T in the centre with the uniformity of 4.5×10^{-4} in the working volume of the target. The magnet contains a main solenoidal winding 558 mm long and 206/144 mm in diameters, and compensating and correcting winding placed at its ends. The windings are made of a NbTi wire, impregnated with the epoxy resin and placed in the horizontal cryostat. The diameter of the «warm» aperture of the magnet cryostat is 96 mm.

The design and technology of the magnet winding are described. Results of the magnetic field map measurements, using a NMR-magnetometer are given. A similar magnet constructed at DAPNIA, CEA/Saclay (France), represented a model for the present development. The MPT array is installed in the beam line of polarized neutrons produced by break-up of polarized deuterons extracted from the synchrotron of the LHE, JINR (Dubna).

The investigation has been performed at the Laboratory of High Energies and at the Laboratory of Nuclear Problems, JINR.

Preprint of the Joint Institute for Nuclear Research. Dubna, 1998

Макет Т.Е.Попеко

Подписано в печать 13.07.98
Формат 60 × 90/16. Офсетная печать. Уч.-изд. листов 1,43
Тираж 375. Заказ 50802. Цена 1 р. 72 к.

Издательский отдел Объединенного института ядерных исследований
Дубна Московской области