

Large Hadron Collider Project

LHC Project Report 248

Tip Heater for Minimum Quench Energy Measurements on Superconducting Strands

P. Bauer*, J. Donnier, L. Oberli

Abstract

Superconducting strands can be characterized by their Minimum Quench Energy (MQE), i.e. the minimum heat pulse needed to trigger a quench in operation conditions (field, temperature, current), in the limit of a (temporally and spatially) δ -shaped disturbance. The sub-mm/ μ s range of perturbation space has only recently been achieved using the electrical graphite-paste heater technique [1]. The present work has put this technique into practice for the strands of the LHC main magnets, which are designed to operate at 1.9K in peak fields of up to 9T [1]. No way has been found yet to calibrate MQE measurements. To make relative statements on the MQE of different samples possible, the reproducibility of the measurements was emphasized. First heater prototypes did not come up to this stipulation. Finally the tip-heater configuration was found to meet the requirements. It generates a heat pulse in a thin resistive graphite paste deposit on top of a small tip that is pressed against the sample with a clamp. The clamp guarantees a maximum of exposure of the sample to the surrounding cryogen. The most striking aspect of repeated measurements on a reference sample is that in open bath conditions the MQE as a function of transport current in subcooled helium can reach hundred times the corresponding value in adiabatic conditions (i.e. with the sample potted in a low conductivity medium). This extraordinary cooling performance of superfluid helium, predicted by many (e.g. [2]) has rarely been shown in superconductor stability experiments.

CERN, LHC Division – Geneva (Switzerland) (*) Supported by the association EURATOM-OEA

Presented at ASC'98 – Applied Superconductivity Conference, Palm Spring, CA, USA, September 1998

Administrative Secretariat
LHC Division
CERN
CH - 1211 Geneva 23
Switzerland

Geneva, 7 October 1998

Tip Heater for Minimum Quench Energy Measurements on Superconducting Strands

P. Bauer*, J. Donnier, L. Oberli
CERN, CH1211 Geneva 23, Switzerland

Abstract - Superconducting strands can be characterized by their Minimum Quench Energy (MQE), i.e. the minimum heat pulse needed to trigger a quench in operation conditions (field, temperature, current), in the limit of a (temporally and spatially) δ -shaped disturbance. The sub-mm/ μ s range of perturbation space has only recently been achieved using the electrical graphite-paste heater technique [1]. The present work has put this technique into practice for the strands of the LHC main magnets, which are designed to operate at 1.9K in peak fields of up to 9T [1]. No way has been found yet to calibrate MQE measurements. To make relative statements on the MQE of different samples possible, the reproducibility of the measurements was emphasized. First heater prototypes did not come up to this stipulation. Finally the tip-heater configuration was found to meet the requirements. It generates a heat pulse in a thin resistive graphite paste deposit on top of a small tip that is pressed against the sample with a clamp. The clamp guarantees a maximum of exposure of the sample to the surrounding cryogen. The most striking aspect of repeated measurements on a reference sample is that in open bath conditions the MQE as a function of transport current in subcooled helium can reach hundred times the corresponding value in adiabatic conditions (i.e. with the sample potted in a low conductivity medium). This extraordinary cooling performance of superfluid helium, predicted by many (e.g. [2]) has rarely been shown in superconductor stability experiments.

I. DEFINING THE MQE MEASUREMENT

A strand cooled by liquid helium in a perpendicular magnetic field and carrying a transport current is locally heated during a short time. The MQE is the minimum heat pulse which just triggers a quench. The hardware for MQE measurements comprises a critical current test-rig, a pulse generator, voltage taps, and a heater (Figure 1). The critical current I_c was defined with the $10^{-14}\Omega m$ criterion. At this resistivity the heat generation is small, so that measurements can be performed at currents above I_c . The following sample has been used as reference:

$d=1.065mm$; $Cu/Sc=1.6$; *coating*: SnAg; $I_c(9T/1.9K)=740A$;
 $I_c(8T/4.2K)=350A$; $\rho_{Cu}(9T)=5.610^{-10}\Omega m$; $\rho_{Cu}(6T)=4.3.10^{-10}\Omega m$.

Originally defined as the quench energy in the limit of δ -like perturbations, experiments and simulations like in (Figure 2) indicate that MQE is independent of pulse duration t_{ini} in the range 0-100 μ s and spatial extension $x_{ini}<0.1mm$. Based on the experiments shown in Figure 2 the pulse time for the experiments has been fixed to 10 μ s, the spatial extension is $\sim 0.6mm$.

Manuscript received September 12, 1998

* Supported by the association EURATOM-OEAW

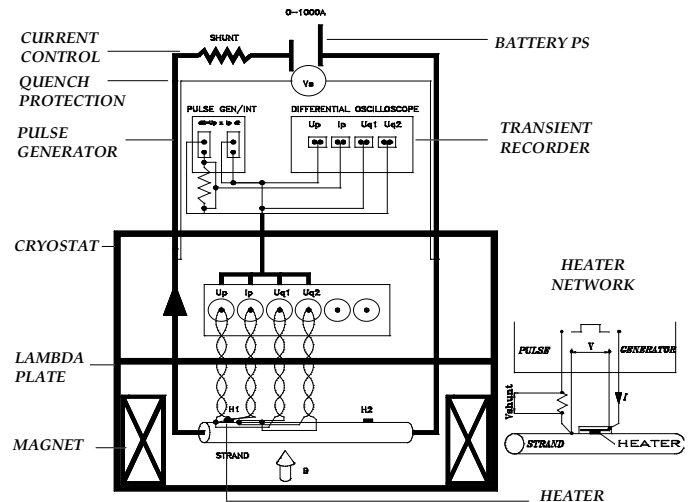

Figure 1: MQE measurement set-up. The bath below the λ -plate can be cooled down to 1.9K through pumping on a JT-valve-heat exchanger circuit. The solenoid is designed for 14T at 1.8K. Current leads and battery PS are designed for 2000A. The sample is wound on a G11 cylinder with the wire axis almost perpendicular to the magnetic field. 3 sets of heaters together with 16 pairs of voltage taps are distributed along the sample. The sample is soldered on top and bottom to the in and out current lead. The pulse generator delivers square pulses (1 μ s-1ms) of up to 100W into a load of 1-70 Ω .

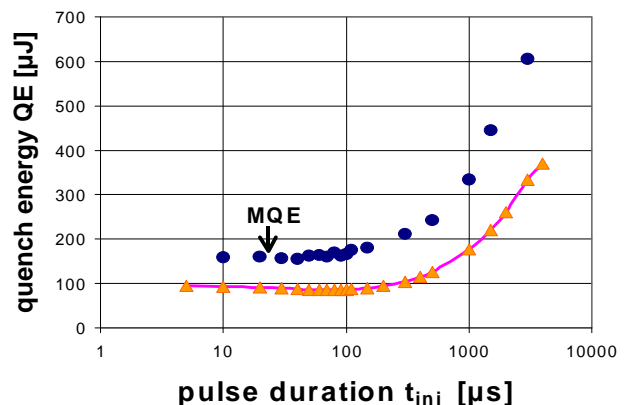

Figure 2: Quench Energy (QE) versus pulse duration t_{ini} , measurement (dots, not calibrated) and simulation (line). Reference wire: 8T, 4.23K, 0.7 I_c , Kapton[®] sandwich heater, heater length 0.3mm. The QE remains constant as long as t_{ini} is smaller than quench decision time ($>30\mu$ s in our experiments).

II. HEATER PROTOTYPES

The heater technique for the LHC-stability investigations was inspired by the successful MQE measurements conducted

at BNL [3] and KEK [4], based on graphite paste heaters. This technique makes use of the particular resistivity of the graphite paste, which is in such a range (some Ωm at $10\text{T}/1.9\text{K}$) that considerable heating power ($1\text{-}100\text{W}$) can be generated in very small volumes (0.001mm^3), thus giving rise to very small thermal time constants ($1\mu\text{s}$). The above mentioned range of low-temperature electrical resistivity is normally covered by semi-conductors. In the course of this work attempts have been made to use a sputtered Ge layer as heating element. Although promising this technique had to be abandoned because of the difficulty to control the various parameters involved. A first heater prototype, very similar to the heaters used at KEK and BNL, the Kapton[®]-sandwich heater, consists of two layers of $25\mu\text{m}$ adhesive Kapton[®] foil which enclose a thin copper strip ($10\mu\text{m}$ thick, 0.3mm large). The upper Kapton layer has a punched hole ($\varnothing 0.3\text{mm}$) which gives way to the underneath copper strip and into which the graphite paste is applied before clamping the heater strip between sample and sample-holder. Although first results were quite encouraging (e.g. Figure 2) this set-up quickly revealed its major weakness: due to a lack of control of pressure between sample and heater, and of the position of the heater with respect to the sample, repeated measurements on a test sample showed a big spread ($>$ factor 2) at $4.2\text{K}/8\text{T}$ (Figure 3). In superfluid helium, where the heat loss from the heater to the helium becomes an additional factor, the reproducibility of the Kapton[®]-sandwich heaters was not acceptable. Even the use of a stainless-steel clamp with the heater current lead embedded (supposed to ensure control of pressure and position) did not produce any substantial improvement.

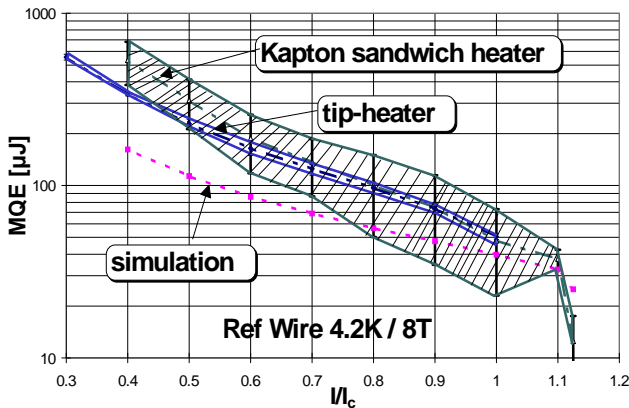

Figure 3: MQE in $4.2\text{K}/8\text{T}$, reference strand; Spread of Kapton[®]-sandwich heater measurements compared to tip heater measurements. The lowest curve (dotted) is a numerical simulation which agrees fairly well with measurement. MQE in pool boiling helium is well understood since [5].

The tip heater electrically generates a heat pulse in the point where tip touches the strand. The electrical tip resistance ($10\text{-}20\Omega$) is given by a $40\mu\text{m}$ graphite paste (Epotecny's E300[®]) deposit on top of the heater-tip together with the contact resistance. The heater tips are small cylinders (1.75mm long, $\varnothing 0.6\text{mm}$) with rounded edges, made of insulating material (=low back loss) and covered with a sputtered $2\mu\text{m}$ Ag coating (=low heat generation due to heater current). A clamp fixes the sample position relative to the tip and the tip is pressed against the sample with a flexible blade, which acts at

the same time as heater current supply. The clamp is made of insulating, machinable glass and exposes on the average 90% of the strand perimeter to the helium bath. The distribution of helium can be shown with the help of Figure 4. The lower part of the clamp has two perpendicular channels to cool the sample from below where it is clamped from above. In the center the sample is pinned from underneath by the heater and exposed to the open bath helium on the upper surface where the upper clamp-part has a dome-like reservoir connected to the bath through a drilling. The heater current lead is a u-shaped copper rod, filed to half the diameter and silver plated at the end which presses against the back of the heater tip. It is bent and generates a considerable pressure ($100\text{g}/0.1\text{mm}^2$). The contact resistance at the back end of the heater is small (some $\text{m}\Omega$). The other end of the heater current lead serves as one pole for both heater voltage and heater current. The second pole for the heater current is a point further away on the sample. The second pole for the heater voltage is a point on the sample, 1cm from the heater.

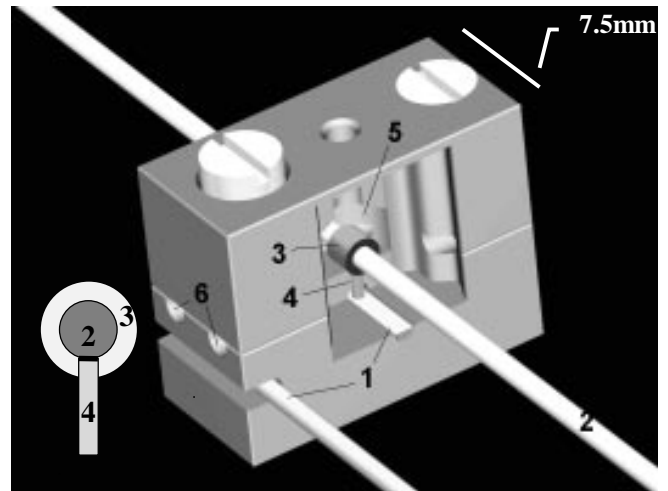

Figure 4: Tip heater drawing: 1 heater current lead, 2 sample, 3 thermo-retracting sleeve (optional), 4 heater tip, 5 helium reservoir (connected to the bath through a channel), 6 helium channels. The heater tip is squeezed between sample on top and the heater current lead from below. The heater current lead acts as a spring.

Measurements on the reference strand showed that the quench decision length rarely exceeds the clamp-dimension. (The quench decision length is the length of a hypothetical normal zone ($T < 15\text{K}$) which produces the quench decision voltage when crossed by the transport current. The quench decision voltage is the voltage at which the just quenching and the just recovering cases split.) Therefore the helium content in the immediate vicinity of the heated spot plays a crucial role.

III. THE SLEEVE EFFECT

In the course of heater development an attempt was made to reduce heat loss by insulating the initially heated "slice" of the strand by means of a thermo-retractable sleeve. A feature of the $\text{MQE}(I/I_c)$ curve of LHC-type strands is that at high currents they are essentially adiabatic (as if "uncooled"). Simulations and measurements (Figure 5) revealed that insulating short sections centered around the heater (using

thermo-shrinking sleeves) extends the adiabatic MQE-regime to lower currents. The sleeve therefore strongly influences the measurement.

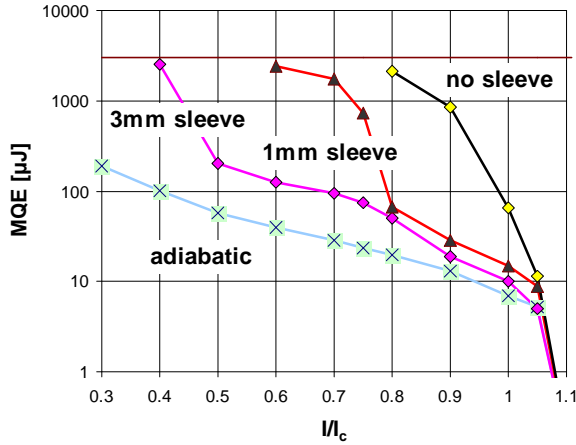

Figure 5: Reference strand measurement, 1.9K/9T. Covering 1mm, 3mm or the whole sample with a thermo-retracting sleeve gradually shifts the onset of the superfluid cooling enhanced MQE regime to lower currents.

The quench decision length (Figure 6) corresponding to the curves in Figure 5 as well reflects the presence of the sleeve:

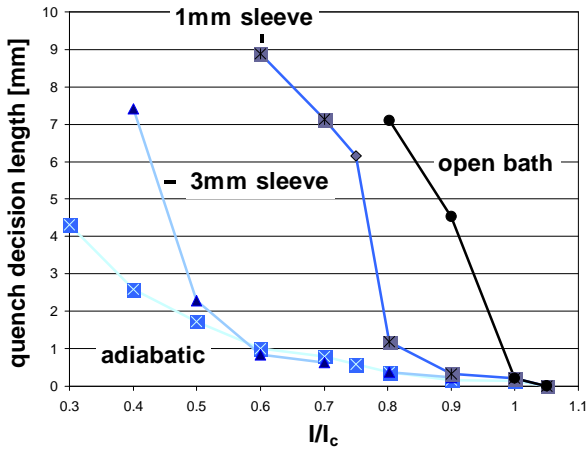

Figure 6: Reference wire measurements: quench decision length in varying cooling conditions, 1.9K/9T.

As long as the quench decision length is smaller than the uncooled part the case is adiabatic. As soon as the Minimum Propagating Zone (MPZ) emerges from under the sleeve, the quench decision length, quench decision time and MQE rise strongly to reach the cooled homologue.

As formerly discussed in [6] metastable normal zones appeared in the sleeve-effect measurements as a consequence of discontinuity in the cooling at the edge of the sleeve. The open bath MQE measurements revealed that for $I/I_c < 0.7$ the set-up could be considered as “cryo-stable” (with steady state heat transfer flux of up to the huge value of 175kW/m^2).

IV. REFERENCE STRAND MEASUREMENTS

To test the predictions of a numerical model (explained in detail in [7]) concerning the effect of cooling to superfluid helium on MQE (Figure 7), experiments have been conducted:

- 1) experiments involving the variation of the cooled perimeter fraction f (Figure 8);
- 2) an investigation of the effect of helium volume on MQE, varying the temperature of the HeII-bath (Figure 9).

The cooled perimeter fraction f determines the strength of heat transfer because it appears in the heat balance equation which describes the problem ([8]) as a multiplier of the cooling function. MQE curves for the same helium volume

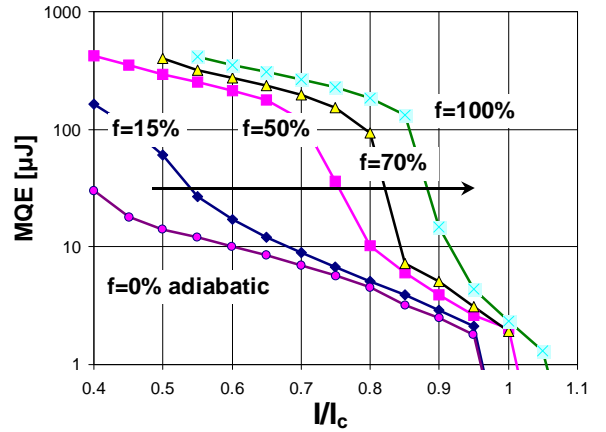

Figure 7: 1.9K / 8.4T reference strand MQE simulation. Effect of cooling parameter f (cooled perimeter fraction) at fixed helium volume (200% of conductor volume). Heat transfer coefficients: $a_k=180\text{W/K}^4/\text{m}^2$ and $a_{fb}=250\text{W/K/m}^2$ for Kapitza heat transfer (“k”) and film-boiling (“fb”). An increased cooled perimeter fraction shifts the bump to higher currents (indicated by arrow). The parameter f has almost no effect on the “height of the bump”, which is determined by the helium volume parameters.

but changing f differ with respect to the occurrence of the “helium bump” (or “superfluid enhancement”). The height of the bump, which refers to the fact that an increase in helium volume can push MQE by a factor of ten or more, is mainly conditioned by the helium volume parameter. The fact that the cooled perimeter fraction f (or the heat transfer coefficient) determines the “position” of the bump along the current axis shows that there is a threshold of cooling strength versus Joule heating which creates two regimes: one in which cooling can act and the other in which cooling, though present, cannot intervene. The analysis of the simulated data reveals that the bump occurs when a recovery of the wire is possible even after the temperature has by far exceeded the critical temperature and partial burn-out along the initially heated length occurred. Heat transfer plays a noticeable role and since quench decision time and quench decision length increase, the effect of cooling is amplified. Above the bump, at high current, the MQE is hardly more than the enthalpy reserve of the wire between bath temp. T_b and a temperature between current sharing T_{cs} and critical T_c . With the maximum temperatures remaining below critical T_c the cooling rates ($\sim \Delta T$) involved are negligible.

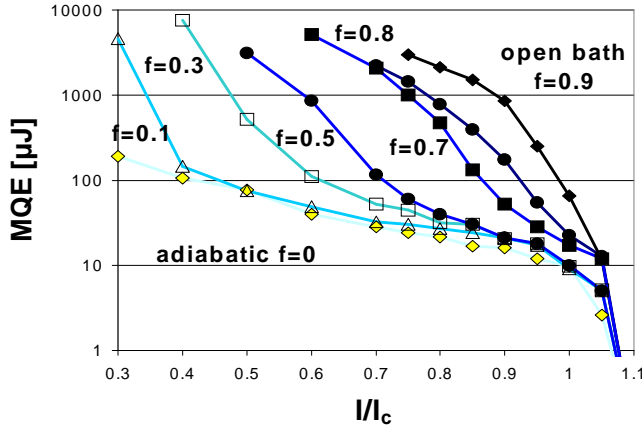

Figure 8: Reference strand MQE measurements at 1.9K/9T. Effect of the cooled perimeter fraction f on MQE. Compare to simulations in Figure 7.

The striking resemblance of f -effect and sleeve-effect can be seen as well in the following example: comparing for example the $I/I_c=0.5$ point in the 1mm sleeve case in Figure 5 and in the $f=0.5$ case in Figure 8 (both have $MQE \sim 3100 \mu J$ and a quench decision length of $\sim 9mm$) reveals that in both cases the cooled fraction of surface along quench decision length is ~ 0.55 . This implies that for MQE only the average cooled surface along the MPZ counts and not the way the cooled spots are distributed.

By varying the temperature of the helium bath between 1.9 and 2.1K one does neither change drastically I_c nor the

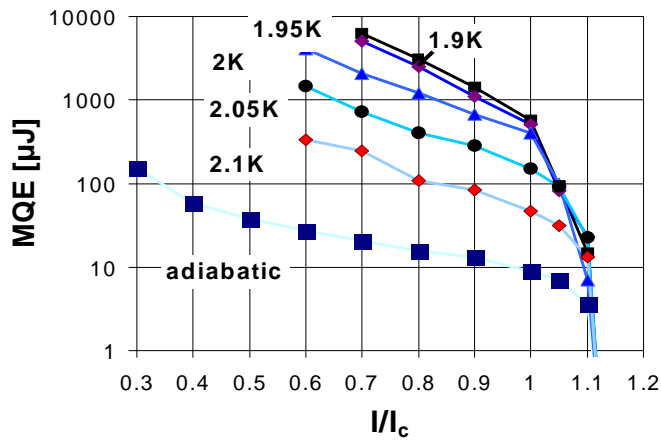

Figure 9: Reference strand MQE measurement: MQE at 9T in open bath conditions with varying bath temperature T_b between 1.9K and 2.1K.

specific heat of the strand. Consequently, and this has been confirmed by measurement, the MQE should not vary in the adiabatic case. On the other hand the open bath MQE reflects the variation in temperature because the apparent heat conductivity of helium II is a rapidly changing function of T reaching its maximum at 1.9K. Together with the specific heat, which varies as well strongly in this temperature range, it influences the heat transfer via the penetration depth of heat and henceforth the helium volume participating in the heat transfer process. In fact the experiment in Figure 9 is

equivalent to varying the helium volume (“Channel limit”) in contact with the sample at a fixed temperature. Model calculations predict that the helium volume parameter affects mainly the amplitude of the superfluid enhancement, in a way similar to the stapled curves in Figure 9. Another prediction of the model, namely the saturation of the helium volume effect at approximately two times the conductor volume could not be verified.

V. CONCLUSIONS

With the aim of characterizing the stability of LHC type strands a Minimum Quench Energy (MQE) measurement technique based on graphite paste tip heaters was developed. The parameter which most influences MQE is the cooling. As shown in repeated measurements on a reference sample the “superfluid enhancement” of MQE, due to the extraordinary heat conduction properties and the relatively high specific heat of superfluid helium, yields a leap in MQE of 10-100 times the adiabatic case. The qualitative understanding of the effect of the cooling parameters on MQE provided by a model (described in [8]), namely that the magnitude of the bump (=superfluid enhancement) is related to the helium volume and its position along the current axis given by the “Kapitza heat transfer coefficient”, has been confirmed experimentally.

ACKNOWLEDGMENT

The authors wish to thank D. Leroy and M. Wilson for their constant support and advice. This work would have been impossible without the cryogenic and technical support from C.H. Denarie, J. Stott, P. Jacquot, J.L. Servais, R. Guigue and P. Chevassus.

REFERENCES

- [1] K. Seo, M. Morita, S. Nakamura, T. Yamada and Y. Jizo, “Minimum Quench Energy Measurements for Superconducting Wires”, *IEEE Trans. on Magn.*, Vol. 32 (4), p. 3089-3093, 1996.
- [1] R. Perin, “The Superconducting Magnet System for the LHC”, *IEEE TMAG*, 1991.
- [2] H. Kobayashi, K. Yasukochi, K. Tokuyama, “Heat Transfer to Liquid Helium in a Narrow Channel Below 4.2K”, *Proc. 6th ICEC, IPC Science & Technology Press, Guildford, England*, p.307, 1976
- [4] M.N. Wilson and R. Wolf, “Minimum Quench Energies of Rutherford Cables and Single Wires”, *IEEE Trans. On Appl. SC*, vol. 7, Nr.2, 1995.
- [3] S.W. Kim, T. Shintomi, N. Kimura, Y. Makida, H. Hirabayashi, T. Mito, A. Iwamoto, J. Yamamoto, A. Kimura, “Experimental Studies of Rutherford Cables for Superconducting Accelerator Magnets”, *IEEE Trans. on Magn.*, Vol.32(4/1), p. 2784-2787, 1996.
- [4] C. Meuris, A. Mailfert, “Influence of the Spacers on the Stability of Channel Cooled Superconducting Coils”, *IEEE Trans. on Magn.*, Vol.17(1), p. 1079, 1981.
- [5] W. Nick, “Theoretical Results of Stability in Pool Boiling Helium-I”, *Stability of Superconductors*, p. 139, Int. Institute of Refrigeration Com. A1/2, Saclay, France, 1981.
- [6] P. Bauer, L. Oberli, R. Wolf, M.N. Wilson, “Minimum Quench Energies of LHC Strands”, paper submitted to the ASC 98, Palm Springs