

KEK Preprint 98-51
June 1998
A

Beam Position Monitor System for KEKB

M. TEJIMA, M. ARINAGA, T. IEIRI, H. ISHII, K. MORI and S. HIRAMATSU



509828

*Submitted to the First Asian Particle Accelerator Conference, APAC98,
KEK, Tsukuba, Japan, March 23 - 27, 1998.*

High Energy Accelerator Research Organization (KEK), 1998

KEK Reports are available from:

Information Resources Division
High Energy Accelerator Research Organization (KEK)
1-1 Oho, Tsukuba-shi
Ibaraki-ken, 305-0801
JAPAN

Phone: 0298-64-5137
Fax: 0298-64-4604
Cable: KEK OHO
E-mail: Library@kekvox.kek.jp
Internet: <http://www.kek.jp>

BEAM POSITION MONITOR SYSTEM FOR KEKB

M.Teijima, M.Arinaga, T.Ieiri, H.Ishii, K.Mori and S.Hiramatsu
KEK, 1-1 Oho Tsukuba-shi, Ibaraki-ken 305, Japan

Abstract

The Beam Position Monitor (BPM) System for KEKB is now under construction with the aim of completion in October 98. The High Energy Ring (HER) and the Low Energy Ring (LER) for KEKB are each equipped with about 450 beam position monitors. The BPM system is aimed at measuring closed orbit distortion with an accuracy better than $1 \mu\text{m}$ within a few seconds. In order to measure the closed orbit for a multi-bunch beam (5000 bunches with high current more than 1A), we improved the pickup electrode, the transmission line, the switch, the front-end electronics and the BPM support. This paper describes the system requirements, the design results of the system, and the laboratory test.

1 Introduction

To make good use of experience gained with the TRISTAN BPM system[1], some components of the BPM system were re-designed in consideration of special features of KEKB[2]. The beam power of KEKB is very strong in comparison with conventional storage rings for electron / positron beams. Close attention has been devoted to the design of the critical parts of the BPM system. The button electrode has been improved to transfer the signal power safely and to suppress higher order mode resonances in the electrode assembly. The BPM block has been made of copper to withstand the heat load, shield against radiation and minimize mechanical deformation. For protection against damage due to radiation at the feed-through, we adopted a short length of semi-rigid cable insulated with PEEK material between the feed-through and the transmission cable. The BPM front-end electronics have been designed to measure the beam position with high accuracy and fast response. The main feature is a common detection circuit with PIN diode multiplexer[3].

2 BPM heads

2.1 Button electrode

We made two types of button electrode structure, as shown Figure 1. To give better mechanical strength to the electrode, the N-type feed-through was modified to a large diameter central rod which is bound by a Spring ring. We adopted button electrodes with normal rods for the LER BPMs and part of the HER BPMs, but the button electrodes of the HER arc section were changed to non-axially-symmetric rods in order to avoid the growth of coupled-bunch instabilities[4].

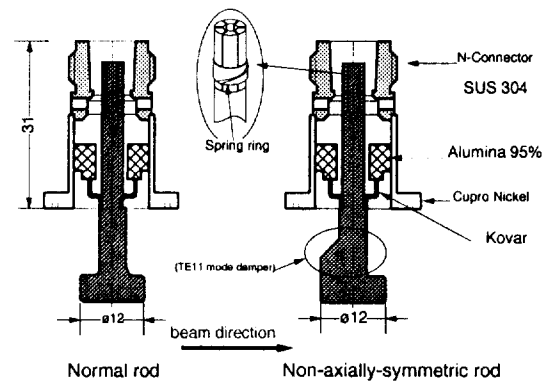

Figure 1: The two types of BPM electrodes for KEKB.

2.2 BPM Heads

The KEKB vacuum chamber is made of an extruded and extracted copper pipe which would not provide accurate or stable enough support for the four feed-throughs by itself. To minimize mechanical deformation of the BPM head, four feed-throughs with electrodes and two stainless steel frames are brazed onto a block made from a solid piece of copper. After calibration of the BPM heads, they are welded onto Q vacuum chambers. With the exception of the interaction region(IR), we have designed seven kinds of BPM heads for both rings of KEKB to match the chamber geometry. These BPM heads are classified as round type or race-track type according to the cross section. The number and dimension of BPM heads are summarized in Table 1. The BPM heads, having cross-sections of round and race-track shapes, as shown in Figure 2, are mainly installed at Quadrupole magnets in the arc sections of each ring. The BPM heads installed in the RF straight sections of both rings have large cross sections. The remaining BPM heads of various cross sections are installed in the injection region and in the crab cavity region.

Table 1: BPM heads for KEKB

BPM head	Type	Dimension	Number
LER arc	round	$\phi 94\text{mm}$	413
HER arc	race-track	104x50mm	387
RF	round	$\phi 150\text{mm}$	55
Local correction	race-track	150x94mm	18
LER injection	race-track	65x48mm	3
HER injection	race-track	76x48mm	3
Crab cavity	race-track	150x50mm	2

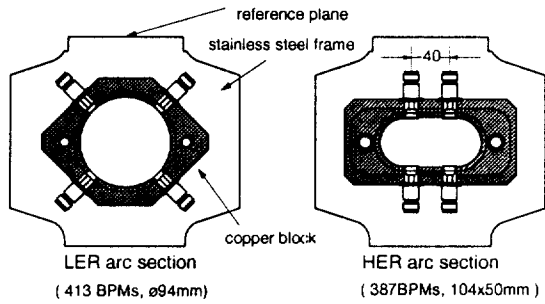

Figure 2: BPM heads of the LER and HER arc sections

2.3 Calibration

Calibration of all monitors is made in the laboratory with a 1.018 GHz signal at a test bench. We have already completed calibration of BPMs for use in the LER arc sections, HER arc sections and RF straight sections. The four electrode signals (A,B,C,D) measured at the bench are normalized to $H=(A-B-C+D)/(A+B+C+D)$ and $V=(A+B-C-D)/(A+B+C+D)$. We obtain the offset (x_0,y_0) between the geometrical center and the electrical center ($H=0,V=0$), and the coefficients (K_x,K_y) for position from the full mapping data. Figure 3 shows mapping plots of the BPM heads. The typical values of the offset and the position coefficients are summarized in Table 2.

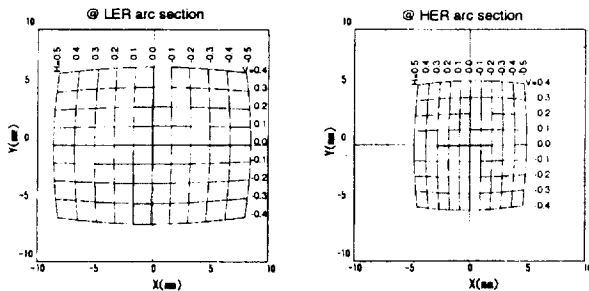

Figure 3: Calibration of the BPM heads of the LER and HER arc section

Table 2: Mean value of offset and coefficient from mapping results

BPM type	Offset		Coefficient	
	X0	Y0	Kx	Ky
LERarc	-0.029	0.017	33.19	33.23
HERarc	0.101	0.179	18.75	27.63
RF	0.173	0.288	53.26	53.31

As another method of calibration[5], a practical model for the output signals of the BPM electrodes was proposed to define a geometric monitor center and the relative gains of the four electrodes on the assumption that each electrode has its ideal position-response function[5]. In a real BPM head, variation of gains from their ideal values displaces its electric center from the ideal one, because the four signals from the BPM heads are influenced by various

loss factors and VSWR of elements such as cables, connectors, switches and so on. With this method, the displacement and relative gain were estimated. The mean values are summarized in Table 3.

Table 3: Mean values of displacements and gains from recalculations

BPM type	Displacement[mm]		Relative gain		
	X0	Y0	g2	g3	g4
LER arc	0.061	-0.094	0.992	0.997	0.986
HER arc	-0.132	-0.055	0.986	1.006	0.998
RF	-0.057	-0.105	0.987	1.011	0.989

The histograms in Figure 4 show the displacement of the geometric center from the reference origin in all LER arc BPMs. The systematic displacement (-0.2mm) of the vertical center illustrates the fact that the reference plane of some heads have been trimmed two times.

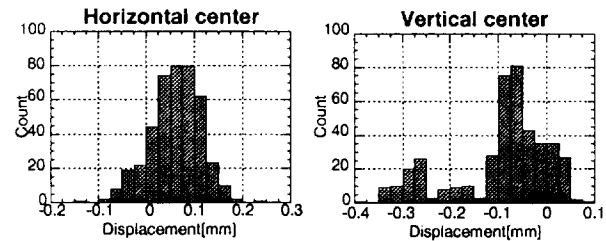

Figure 4: Histograms of the displacements of the geometric center.

3 Performance of signal processing

A dual four-channel multiplexer and a signal processor module which are made as VXI (VME-bus Extensions for Instrumentation) have been developed for the electronics of the BPM system in KEKB. The multiplexers were made from Pin diode switches because the switching fluctuation of the insertion loss is very low. Four signals from four electrodes are selected by the multiplexer, and detected by a common signal processor. The signal processor consists of a super-heterodyne circuit, a 16-bit ADC and a Digital Signal Processor (DSP). In order to measure beams with any multi-bunch configuration, a pickup frequency of 1.018 GHz has been chosen, that is, twice the accelerating RF frequency, and the 10240th harmonic of the revolution frequency (~99.9KHz).

We tested the performance by using a prototype signal processing module. We input to the module four signals derived from a the source signal (1.018 GHz) distributed by an RF divider circuit, and the measurement was repeated many times for the test data. Then the sampling conditions was changed as follows: FFT measurements at 128, 512, and 2048 points, and the average of 128, 32, and 8 measurements. As a result of the test, we confirmed the S/N ratio to be more than 90 dB and the measuring time less than one second per electrode, as shown in Figure 5.

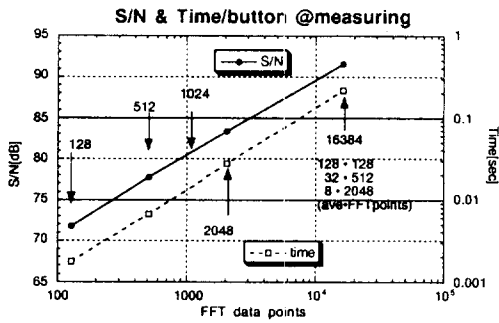

Figure 5: S/N ratio and measuring time

We also measured beam positions repeatedly by using the prototype at SPring-8. Figure 6 shows the history of the beam position for six hours. We could not measure the S/N ratio because of some fluctuations of the real beam positions, but we could confirm the position resolution within a few microns at least.

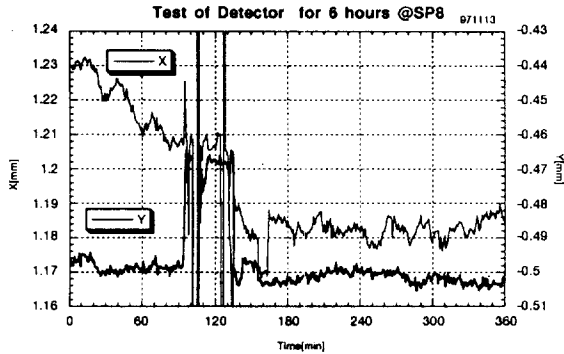

Figure 6: Results of the beam test at SPring 8

4 BPM system for the orbit feedback at the interaction point

For maintaining the optimum collision condition of the two rings at KEKB, we will construct a special BPM system to measure orbit offset and crossing angle on the basis of the beam-beam deflection technique[6][7][8]. Since the beam current of the KEKB is very high, we can not install such electrode as directional couplers to measure the positions of the two beams separately. We elected to install two special BPM heads each having eight button electrodes inside the QCS magnets around the interaction point(IP) as shown in Figure 7. Four normal BPM heads at the exit of the QCSs will be also incorporated into the feedback operation in order to back up these eight-electrode BPMs. The eight electrode signals are readout by the same electronics employed in the closed orbit BPM system -- that is, a multiplexer and a signal processor module. The signal processor detects the combined output signal of both beams, but each beam position is separable by analyzing the non-linearity of the pick-up sensitivity from the eight outputs, because the unknown parameters ($X_e^-, Y_e^-, I_e^-, X_e^+, Y_e^+, I_e^-$) are fewer than number of measured data points (8 outputs from the

electrodes). If an FFT analysis of the signals is performed under at 1024 sampling points, the S/N ratio will be about 80 dB (see Figure 5) within 60 msec per four signals. Therefore it is possible to measure the orbital offset with a resolution less than 5 μ m with 10 Hz signal processing. Figure 8 shows a block diagram of the BPM system for orbit feed-back at the IP in KEKB

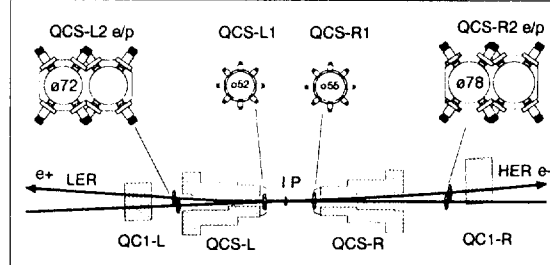

Figure 7: Layout of BPMs around IP in KEKB

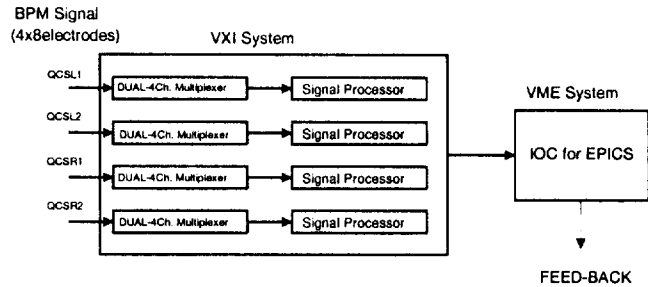

Figure 8 : Block diagram of BPM system for orbit feed-back in KEKB

5 References

- [1] H.Ishii et al., "BEAM POSITION MONITOR SYSTEM OF TRISTAN MAIN RING", Proc. 1987 the 6th sympo. on Accel. Sci. and Tech., Tokyo, Japan.
- [2] N.Akasaka et al., "Design of Beam Position Monitor System for KEKB", Proc. 1996 Europ. Part. Accel. Conf., Sitges (Barcelona), Spain, June 10-14. /KEK Preprint 96-48.
- [3] M.Teijima et al., "BEAM POSITION MONITOR SYSTEM for KEKB", Proc. 1997 the 11th sympo. on Accel. Sci. and Tech., SPring 8, Hyogo, Japan.
- [4] T.Obina et al., "Damped Button Electrode for B-Factory BPM System", Proc. 1995 Part. Accel. Conf. , Dallas, Texas, U.S.A./KEK Preprint 95-41.
- [5] K.Satoh and M.Teijima, "Calibration of KEKB Beam Position Monitor", Proc. 1997 Part. Accel. Conf., Vancouver, BC, Canada, May 12-16. /KEK Preprint 97-33.
- [6] Y.Funakoshi et al., "Feasibility Study of an Orbit Feedback System for the KEKB Facility", Proc., 1995 IEEE Particle Acc. Conf., Dallas, Texas. U.S.A./KEK Preprint 95-32.
- [7] M.Teijima et al., "Beam Position Monitor for an Orbit Feedback System" , Proc. 1995 the 10th sympo. on Accel. Sci. and Tech., Hitachinaka, Japan.
- [8] M.Tobiyama., private communications.

