



Large Hadron Collider Project

LHC Project Report 162

**THE NEW SUPERFLUID HELIUM CRYOSTATS FOR THE SHORT STRAIGHT SECTIONS OF THE
CERN LARGE HADRON COLLIDER (LHC)**

W. Cameron,² Ph. Dambre,⁴ T. Kurtyka,² V. Parma,¹ T. Renaglia,² J.M. Rifflet,³ P. Rohmig,¹ B. Skoczen,¹ T.
Tortschanoff,¹ Ph. Trilhe,² P. Vedrine,³ and D. Vincent⁴

Abstract

The lattice of the CERN Large Hadron Collider (LHC) contains 364 Short Straight Section (SSS) units, one in every 53 m long half-cell. An SSS consists of three major assemblies: the standard cryostat section, the cryogenic service module, and the jumper connection. The standard cryostat section of an SSS contains the twin aperture high-gradient superconducting quadrupole and two pairs of superconducting corrector magnets, operating in pressurized helium II at 1.9 K. Components for isolating cryostat insulation vacuum, and the cryogenic supply lines, have to be foreseen. Special emphasis is given to the design changes of the SSS following adoption of an external cryogenic supply line (QRL). A jumper connection connects the SSS to the QRL, linking all the cryogenic tubes necessary for the local full-cell cooling loop [at every second SSS]. The jumper is connected to one end of the standard cryostat section via the cryogenic service module, which also houses beam diagnostics, current feedthroughs, and instrumentation capillaries. The conceptual design fulfilling the tight requirements of magnet alignment precision and cryogenic performance are described. Construction details, aimed at minimizing costs of series manufacturing and assembly, while ensuring the high quality of this complex accelerator component, are given.

¹ LHC Division, ² EST Division, ³ CEA SACLAY DAPNIA (F), ⁴ CNRS, IPN (F)

*Presented at
the Cryogenic Engineering Conference/International Cryogenic Materials Conference, CEC/ICMC 97, Portland U.S.A.*

Administrative Secretariat
LHC Division
CERN
CH - 1211 Geneva 23
Switzerland

Geneva, 15 January 1998

INTRODUCTION

The design and construction of the first prototype Short Straight Section,¹ carried out in the years from 1992 to 1994, allowed its successful integration and operation in the LHC test string.² However, major changes of the machine layout, cryogenic distribution and magnet powering schemes since 1994 imposed a review of the conceptual design of the Short Straight Sections. Industrial techniques, in view of series production and cost optimization (reductions), have been implemented. Following the approval of the LHC project, a new collaboration for the design, prototyping, and industrial series production follow-up was concluded between CERN and two French Institutes, CEA and CNRS. Due to the special contribution of the host country to the LHC project, the existing collaboration with CEA/Saclay has been extended to the CNRS laboratory in Orsay and covers the design of the quadrupole magnets, the complete cold mass assembly (CEA) and the integration into the SSS cryostat (CNRS).

NEW SSS LAYOUT

Figure 1 presents a drawing of the new LHC SSS with associated equipment. A major change from the previous design centers the quadrupole between neighboring dipole magnets. This places the corrector magnets on both sides of the quadrupole. Furthermore, the two quadrupole families (focusing and defocusing) are powered independently from the dipoles, thus reducing the integrated length of the tuning quadrupoles.

The integration of the cold mass (helium enclosure) within the quadrupole assembly now permits a vertical assembly with a common inertia tube, similar to CEA's design for the HERA quadrupole units. This considerably improves alignment precision for the magnets when compared to the first SSS prototype.

The implementation of a separate cryogenic feed line, QRL,³ simplified the cryostat layout of the SSS. The cryogenic control valves, formerly located within the technical service module, are now housed in a dedicated pre-tested valve module. In addition, all cryogenic supply lines for the machine cryostat have been transferred to this feed line with exception of the thermal shield cooling lines. The jumper connection cryogenically links every second SSS to the QRL via the cryogenic service module, QQS. This permits the operation of a 107 m long cell. In addition to the cryogenic interconnect with its liquid helium phase separator, QQS of the SSS also contain beam position monitors, the protection diodes of the quadrupole, conduction cooled current leads and the cold mass instrumentation feedthroughs.

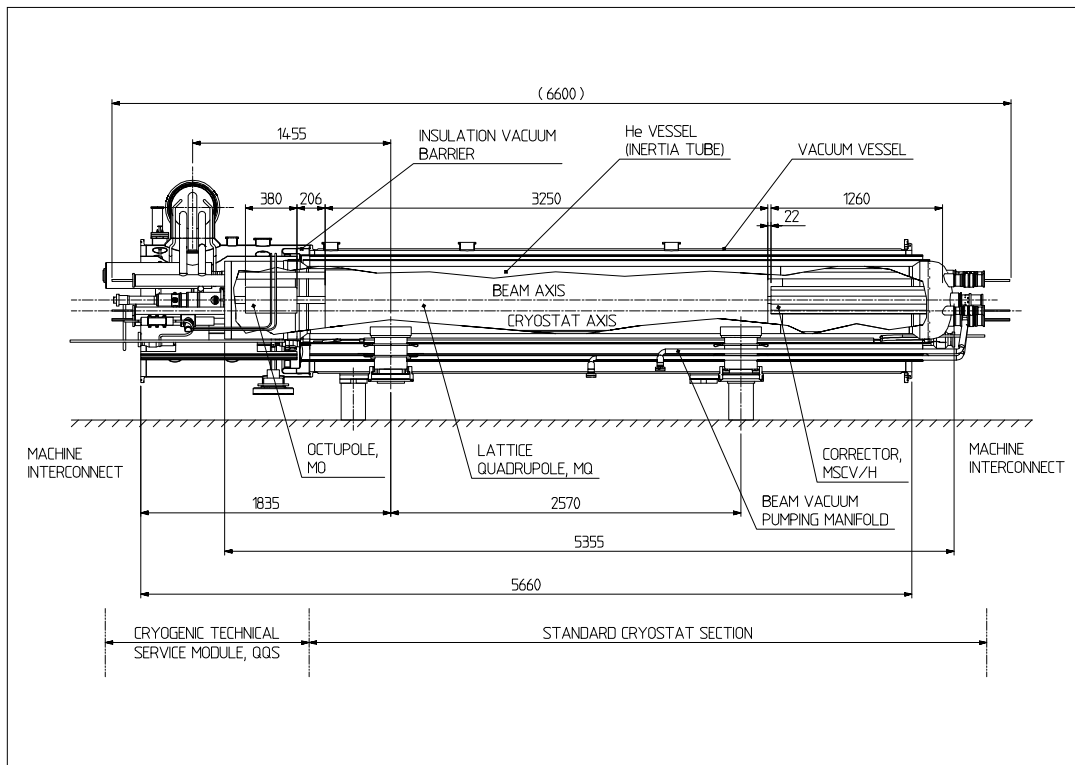

Figure 1. LHC Short Straight Section (arc) with jumper connection, cryogenic technical service module and vacuum barrier

The LHC machine requires 12 different types of cryogenic jumper connections, depending on the slope of the machine and their location within the cryogenic loop.

To cope with possible failure of machine components and to minimize machine down time, a sector isolation of the cryostat insulation vacuum, the beam lines and the cryogenic circuitry has been proposed.⁴ If finally adopted, this will be accomplished with cryostat vacuum barriers and bus bar pressure plugs in every second cell (214 m), and with the help of isolation valves in the beam vacuum and thermal shield line at 3 points in each of the eight 2.9 km long machine sectors.

DESIGN IMPROVEMENTS FOR SERIES MANUFACTURE

Based on the experience gained with the first prototype, and to allow implementation of the conceptual changes mentioned, the LHC cryostat design and, in particular, that of the SSS has been reviewed.

Cold mass and helium enclosure

The quadrupole magnets, the corrector magnets, and all standard cryostat section bus-bars are contained in the inertia tube. This 5.36 m long stainless steel tube provides not only the stiffening element for this assembly but also serves as the helium pressure vessel for the SSS. The tube and all it contains is called the cold mass. The feasibility of centering the magnets inside this inertia tube by means of a series of keys positioned by cylindrical pins

and blocked by bolts, was confirmed with the first two prototypes. One of the two end covers will be of a dished type and identical to those of the dipole. The fixation of the BPM supports, aligned accurately to precisely drilled reference plugs on the inertia tube, imposes the requirement that other end cover be flat, with all passage tubes for bus bars, diode housing and current feedthroughs welded onto it.

Standard Cross-section of the Cryostat

The Short Straight Section cryostat incorporates many design features identical to the dipole.⁵ The thermal insulation system (Figure 2) consists of two actively cooled shields, the radiation screen at 4.5-20 K, and the thermal shield at 50-75 K. Extruded aluminum profiles of symmetric section have been adopted for both thermal shield bottom trays. Integrated cooling channel and clamp-in grooves for the upper pre-formed sheet segments, are included in the extrusion. Compared to earlier designs, this avoids mechanical instability due to asymmetric welding of the cooling tubes onto the bottom tray and to the pressure forces created in the interconnect bellows. This construction also provides a low manufacturing cost.

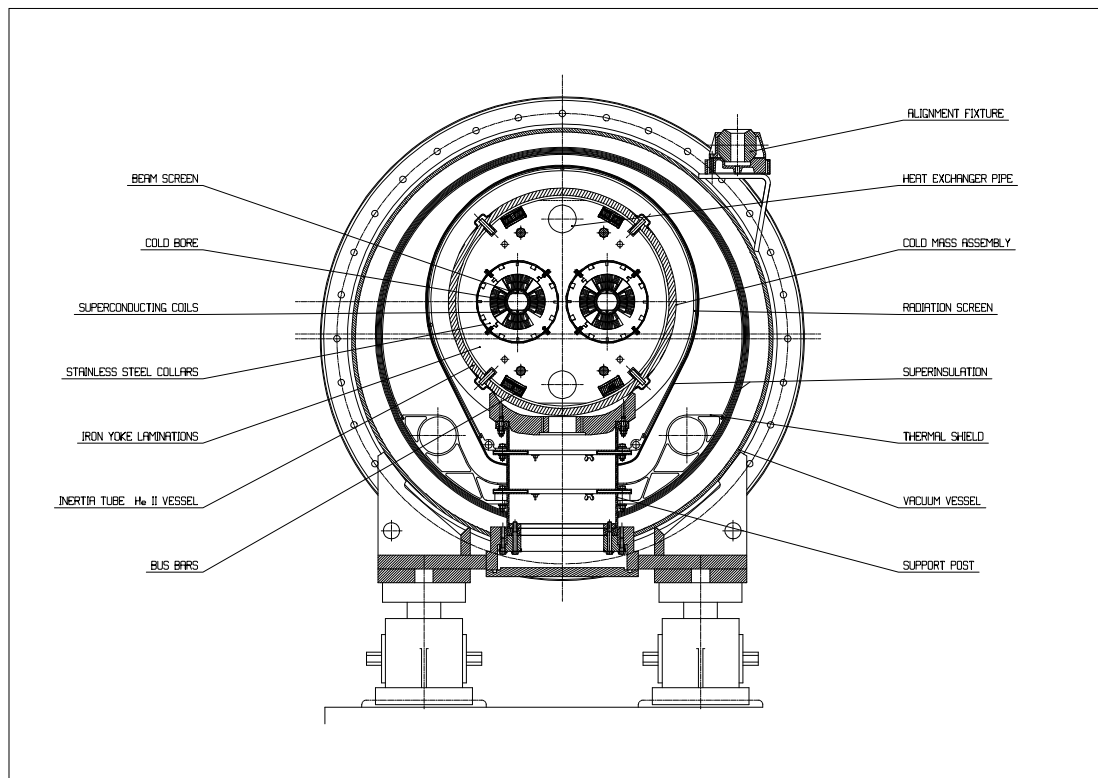

Figure 2. Cross-section of the LHC Short Straight Section (arc) with its quadrupole and cryostat

The cold support system⁶ consists of two low heat leak, fiber glass reinforced, epoxy resin molded, support posts with integrated heat sink plates at the 4.5-20 K and 50-75 K levels. These plates also provide mechanical support for the thermal shields. With one fixed support post and a second allowing sliding for compensation of the thermal contraction between cold mass and vacuum vessel, a mechanical reproducibility, after thermal cycles, of the magnet position of better than 0.2 mm r.m.s. is expected.

All heat sinks, namely those of the fiber glass reinforced support posts and those of the shield segments, are obtained by welding. To separate the heat sink and anchoring functions, the support post heat sinks and supporting plates are linked by flexible aluminum multi-foil straps to the thermal shield bottom trays.

The choice of prefabricated Multilayer Superinsulation (MLI) blankets with Velcro™ fixtures has been confirmed by the first prototype as the most economical solution (reproducibility of quality and minimization of assembly time). Forthcoming tests with a Cryogenic Thermal Model (CTM), simulating different operating conditions, will validate the final type and set up of MLI for the 4.5-20 K radiation screen. For the 50-75 K thermal shield, blankets of MLI containing 30 layers of double aluminized Mylar™ (DAM) or single aluminized Mylar™ (SAM) type with polyester spacers will be used.

The vacuum vessel for the standard cryostat section of the SSS will be made out of Ø 914 (36”) standard carbon steel tubes, as for the dipole cryomagnet. A comparison of costs quoted by possible future suppliers showed cost reduction of up to 30% for surface protected carbon steel tubes versus stainless steel tubes.

The same study showed that the choice between cast steel support modules versus welded ones, both integrating all functions for supporting and lifting, are strongly dependent on the labor costs of the manufacturer.

Vacuum Barrier

Vacuum barriers isolating the cryostat insulation vacuum every 2 cells (214 m) have been designed using two approaches that give similar mechanical and thermal performance. In the first prototype SSS, the vacuum barrier was made of corrugated cylindrical stainless steel segments (bellows), while a second unit, made from pre-impregnated fiber glass reinforced epoxy resin panels,⁷ has been installed for two years in a dedicated module integrated into the LHC test string. The reliability of the composite/metal bonding for the welded interface to stainless steel cryogenic tubes on the composite barrier showed weakness but not degradation of leak tightness was observed. New prototypes and associated cost comparison analysis between the technologies will lead to a final choice before the end of this year.

Cryogenic Technical Service Module (QQS)

With the introduction of the separate cryogenic feed line, all cryogenic control valves (Joule-Thomson, quench relief and other fill and control valves) formerly placed within this module are now located in a dedicated feed line valve box. Nevertheless, every second SSS is linked to the cryogenic distribution line by a jumper connection, equipped with bellows, housing up to eight supply lines (see Figure 3). Special attention has been paid to obtaining a low force compensation for any mechanical offset correction, in order not to interfere with the SSS magnet alignment.

There are 12 different types of QQS. The types are partially governed by the need to integrate a helium phase separator with its incorporated heat exchanger loop and control instrumentation. Depending on the SSS position along the tunnel slope, the separators are connected such that cooling of the upward cell is provided.

Conduction cooled 60 A current leads for the individual dipole correctors, as well as the cold mass instrumentation capillaries, are integrated in the QQS.

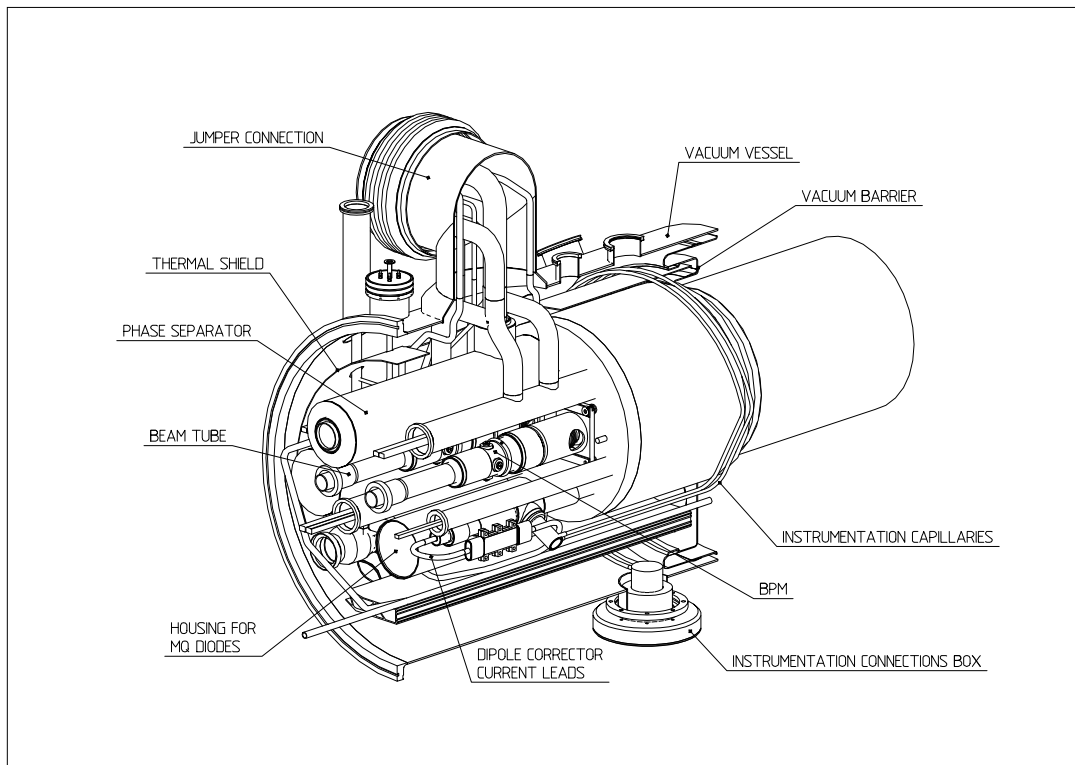

Figure 3. Cryogenic Technical Service Module (QSS) jumper connection type with phase separator

To cope with failures of the quadrupole protection diodes or corrector, their electrical connections are accessible via the cryostat interconnect. This permits the exchange of faulty diodes, or the use of spare bus-bars for by-passing the faulty correctors in a local intervention.

The two beam position monitors are fixed to, and thus integrated with, the SSS beam screens. These sub-assemblies must be absent during the cold magnetic measurements and will be inserted after all cold tests have been finished. They require pre-aligned supports attached to the cold mass end cover to permit easy assembly.

Three SSS in each arc, with beam vacuum sectorisation functions, will have manual operated valves integrated into the beam tubes upstream of the BPMs.

CRYOGENIC PERFORMANCES

Based on the stringent cryogenic specification for the heat loads at different temperature levels, the thermal performance of the SSS was analyzed. The thermal insulation system, in particular the active 4.5-20 K radiation screen, needs further experimental validation in the CTM before a final choice for the LHC cryostat system can be made. Table 1 shows the estimated cryogenic performances of an LHC Arc Short Straight Section containing jumper connection and vacuum barrier under different operation modes. Beam-introduced heating, such as photoelectron deposition and beam gas scattering, is not considered in this table.

Table 1. Estimated cryogenic performances of a LHC Short Straight Section (arc) containing jumper connection and vacuum barrier under different operation modes in Watts

Component	Static 50-75 K	4.5-20K	1.9 K	Nomina 1 50-75 K	(without 4.5-20K	static) 1.9 K
Standard cryostat section						
- Cold support post (2)	9.5	1.4	0.04			
- Thermal shield	13.2					
- Radiation screen		0.52				
- Beam pumping manifold	0.8		0.26			
- Cold mass			0.06			
- Beam screens			0.1			
QOS with jumper connect.						
- Thermal shield	4.44					
- Radiation screen		0.07				
- Beam Position Monitors		0.83	0.3			
- Dipole correct. current leads	5.2	1.1	0.11	0.34	0.08	0.15
- Phase separator and piping			0.02			
- Cold mass instrumentation			0.53			
- Insulation vacuum barrier	5.1	0.24	0.37			
Resistive heating						
- Quad. + correctors splices						0.62
TOTAL	38.24	4.16	1.79	0.34	0.08	0.77

DESIGN STATUS AND FUTURE PROGRAM

Design studies are proceeding for the cold mass mechanical design as well as for the Technical Service Module. Based on a similar design with the dipole cryostats, the standard section cryostat of the SSS is well advanced and prototype tendering is under way.

Close contacts with industry allowed early integration of economical manufacturing technologies in the SSS design, with a view to low cost series production. Following a technical review within the three collaborating institutes in October, 1997, components for two new prototypes, one with jumper connection and vacuum barrier, the other without will be ordered from industry.

Cold mass assembly at CEA/Saclay and final cryostating at CERN with the assistance of CNRS/Orsay is planned to start in the second half of 1998. It is expected to have a first SSS cold-measured in 1999 and both SSS integrated in the new LHC Test String before the year 2000.

CONCLUSIONS

Based on the experience gained with the first prototype built, which has been operating successfully since 1994 in the LHC Test String, a new generation of LHC Short Straight Section cryostats has been designed. Apart from conceptual changes, the integration of low cost components (pipeline tubes) and technologies (e.g. extruded thermal shield trays and cast supporting modules) was carried out. Considerable effort was invested to optimize all heat sinks (100% welded), a weak point of the first prototype. Attention was also given to

push standardization of the 364 SSSs of the LHC arc as far as possible in the manufacturing process, and to achieve component failure repair within short machine down time.

ACKNOWLEDGMENTS

The authors wish to thank the members of the Short Straight Section Working Group at CERN and the teams in the three institutes involved in the design of the SSS. Thanks also to our colleagues of the LHC-ACR group for the help on the heat load estimation and the fruitful discussions which lead to the present cryostat design.

REFERENCES

1. W.Cameron, B. Jenny, G. Riddone, P. Rohmig and R. van Weelderen “Design and construction of a prototype superfluid helium cryostat for the Short Straight Sections of the CERN Large Hadron Collider (LHC)”, *Advances in Cryogenic Engineering*, Vol. 39 (1994).
2. T. Tortschanoff et al., “The Short Straight Sections for the LHC”, *Particle Accelerator Conference*, Vancouver (1997).
3. V. Benda et al. “Conceptual design of the cryogenic system for the Large Hadron Collider (LHC)”, *European Particle Accelerator Conference*, Sitges (1996).
4. M. Bona et al. “Cryogenic and vacuum sectorisation of the LHC arcs”, *LHC Project Report 60* (1996).
5. J.C. Brunet, V. Parma, G. Peon, A. Poncet, P.Rohmig, B. Skoczen and L.R. Williams, “Design of the second series 15 m LHC prototype Dipole magnet cryostats”, presented at this conference.
6. M. Mathieu, V. Parma, Th.Renaglia, P. Rohmig and L.R. Williams, “Supporting systems from 293 K to 1.9 K for the Large Hadron Collider (LHC) cryo-magnets”, presented at this conference.
7. B. Jenny, P. Rohmig and J.M. Uriarte, “A composite vacuum barrier for the LHC Short Straight Section”, *Advances in Cryogenic Engineering*, Vol. 41A (1996).