

88

KEK Preprint 97-28
May 1997
A

Dispersion in the Interaction Point

S. PETRACCA and K. HIRATA

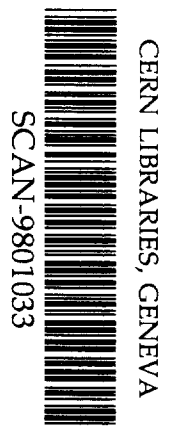

5w4803

*Submitted to the 1997 Particle Accelerator Conference,
May 12 - 16, 1997, Vancouver, BC, Canada.*

** From April 1, 1997, High Energy Accelerator Research Organization (KEK) was newly established. The new organization is restructured of three research institutes, National Laboratory for High Energy Physics (KEK), Institutes of Nuclear Study (INS), Univ. of Tokyo and Meson Science Laboratory, Faculty of Science, Univ. of Tokyo.*

High Energy Accelerator Research Organization (KEK), 1997

KEK Reports are available from:

Information Resources Division
High Energy Accelerator Research Organization (KEK)
1-1 Oho, Tsukuba-shi
Ibaraki-ken, 305
JAPAN

Phone: 0298-64-5137
Fax: 0298-64-4604
Cable: KEK OHO
E-mail: Library@kekvox.kek.jp (Internet Address)
Internet: <http://www.kek.jp>

Dispersion in the Interaction Point

S. Petracca*, Dip. di Scienze Fisiche E.R. Caianiello, Univ. of Salerno and I.N.F.N. Salerno, Italy
and

K. Hirata†, KEK, High Energy Accelerator Research Organization, Tsukuba 305, Japan

Abstract

In the presence of a dispersion at the interaction point, the betatron and the synchrotron oscillations affect each other. Just as linear effects, the beam-beam kick modifies the synchrotron tune, the bunch length, the energy spread etc, as well as the betatron tune and the Twiss parameters. Dispersion is no longer enough to describe the coupled dynamics and we need two more parameters.

1 INTRODUCTION

The dispersion is a dangerous concept. Usually [1, 2], it is defined in terms of the closed orbit (\mathbf{x}_0) in the betatron phase space of a fictitious particle with a constant energy ($D \equiv [\mathbf{x}_0(E) - \mathbf{x}_0(E_0)] / (E - E_0)$). Once upon a time, this was a good definition with a full physical meaning for the coasting beam accelerators. In modern accelerators with RF cavities, particularly in electron rings, however, no particle has a constant energy. The dispersion defined as above is a kind of a limiting concept which has a physical meaning only in the limit with a vanishing synchrotron tune: $\nu_s \rightarrow 0$. If it was a useful concept, why do not we define "bisersion" as a closed orbit difference in the synchrotron phase space for a particle with a fixed slope (y')?

To discuss the interaction between betatron and synchrotron motions, we should use concepts consistent with the synchrotron motions. Otherwise, our discussion will become quite complicated and we might need an acrobatic manipulation of logics to be accurate. (It is something like to discuss quantum mechanics using classical concepts).

The effects of dispersion at the interaction point (IP) has been studied for long time [3, 4]. The synchrotron motion was assumed to be unaffected and the interest was only on the effect of synchrotron motion on the betatron motion. There are several reasons to study it more carefully now. First of all, the monochromatic collision[5] became an important and practical issue for tau-charm factories. In addition, for future high performance colliders, we need more detailed control of dispersion and a deeper knowledge of it.

This paper is organized as follows. In Sect. 2 we discuss the factorization of a general 4×4 symplectic matrix. Then in Sect. 3, the one-turn map is parametrized for the case with dispersion at the IP. Conclusions follow under Sect. 4.

2 GENERAL 4×4 SYMPLECTIC MATRIX AND ITS FACTORIZATION

It is well known that any stable symplectic 2×2 matrix m can be represented as[1]

$$m = t \begin{pmatrix} \cos \mu & \sin \mu \\ -\sin \mu & \cos \mu \end{pmatrix} t^{-1}, \quad (1)$$

where $\mu = 2\pi\nu$, ν being the tune. Here

$$t = \begin{pmatrix} \sqrt{\beta} & 0 \\ -\alpha/\sqrt{\beta} & 1/\sqrt{\beta} \end{pmatrix}.$$

In Ref. [6], it was shown that any stable symplectic 4×4 matrix M can be factorized as follows:

$$M = H \text{diag}(m_u, m_v) H^{-1}, \quad (2)$$

where

$$H = \begin{pmatrix} bI & h \\ \bar{h} & bI \end{pmatrix}, \quad h = \begin{pmatrix} \zeta & \eta \\ \zeta' & \eta' \end{pmatrix}, \quad (3)$$

and $m_{u(v)}$ is m in Eq.(1) with suffices of $u(v)$ for μ , α and β . Here, h is a 2×2 matrix and

$$\bar{h} = j h^t j = \begin{pmatrix} -\eta' & \eta \\ \zeta' & -\zeta \end{pmatrix}, \quad j = \begin{pmatrix} 0 & 1 \\ -1 & 0 \end{pmatrix}.$$

Here, $b = \sqrt{1 - \det(h)}$ is a constant. Note that H , as well as M , is symplectic in 4-dim sense:

$$H^t J H = J, \quad J = \text{diag}(j, j).$$

The 4×4 symplectic matrix has 10 free parameters. The u and v modes have 3 parameters each (ν , α , β). We need 4 parameters, η , η' , ζ , and ζ' to characterize the coupling between two degrees of freedom.

In Ref.[7], it was shown that when the dispersion D vanishes in cavities, then η is identical to D and ζ vanishes all over the ring. For more general cases, D and D' are not sufficient and we need h , in particular ζ and ζ' . To be precise,

$$\lim_{\nu_s \rightarrow 0} h = \begin{pmatrix} 0 & D \\ 0 & D' \end{pmatrix}. \quad (4)$$

We thus call η the (generalized) dispersion.

The normal modes (u, u') and (v, v') are defined as

$$(u, u', v, v')^t = \text{diag}(t_u^{-1}, t_v^{-1}) H^{-1} \mathbf{x},$$

where \mathbf{x} are 4-vectors (physical variable): $\mathbf{x}^t = (y, p, z, \delta)$. It seems convenient here to discuss the expressions of the

* Also KEK as a Fellow of the Canon Foundation Europe.

† Also Univ. of Salerno as a Visiting Researcher.

beam sizes under the assumption that the beam envelope matrices for the normal modes are given as follows: $\langle u^2 \rangle = \langle u'^2 \rangle = \epsilon_u$, $\langle v^2 \rangle = \langle v'^2 \rangle = \epsilon_v$, and $\langle uu' \rangle = \langle vv' \rangle = \langle uv \rangle = \langle uv' \rangle = \langle vu' \rangle = \langle u'v' \rangle = 0$. At a glance, one can get, for example,

$$\begin{aligned} \langle y^2 \rangle &= b^2 \beta_u \epsilon_u + \{\eta^2 + (\beta_v \zeta - \alpha_v \eta)^2\} \beta_v^{-1} \epsilon_v \\ \langle p^2 \rangle &= b^2 \gamma_u \epsilon_u + \{\eta'^2 + (\beta_v \zeta' - \alpha_v \eta')^2\} \beta_v^{-1} \epsilon_v \\ \langle z^2 \rangle &= \{\eta^2 + (\alpha_u \eta + \beta_u \eta')^2\} \beta_u^{-1} \epsilon_u + \beta_v b^2 \epsilon_v \\ \langle \delta^2 \rangle &= \{\zeta^2 + (\alpha_u \zeta + \beta_u \zeta')^2\} \beta_u^{-1} \epsilon_u + b^2 \gamma_v \epsilon_v \\ \langle yp \rangle &= -\alpha_u b^2 \epsilon_u + \{\gamma_v \eta \eta' - \alpha_v (\eta \zeta' + \zeta \eta') + \beta_v \zeta \zeta'\} \epsilon_v \\ \langle yz \rangle &= -b(\alpha_u \eta + \beta_u \eta') \epsilon_u - b(\alpha_v \eta - \beta_v \zeta) \epsilon_v \\ \langle y\delta \rangle &= b\beta_u (\alpha_u \zeta + \beta_u \zeta') \epsilon_u + b(\gamma_v \eta - \zeta) \epsilon_v, \end{aligned} \quad (5)$$

where $\gamma = (1 + \alpha^2)/\beta$.

3 BEAM-BEAM COLLISION

We assume that there is a single IP in the ring and there is a dispersion η_0 . The revolution matrix from the IP to IP without the beam-beam kick is

$$M_{arc} = H_0 \text{diag}(m_y^0, m_z^0) H_0^{-1},$$

where H_0 is H , Eq.(3), with h being replaced by

$$h_0 = \begin{pmatrix} 0 & \eta_0 \\ 0 & 0 \end{pmatrix},$$

$$m_y^0 = \begin{pmatrix} \cos \mu_y^0 & \beta_y^0 \sin \mu_y^0 \\ -1/\beta_y^0 \sin \mu_y^0 & \cos \mu_y^0 \end{pmatrix},$$

and m_z^0 being m_y^0 with y replaced by z . Note that for usual electron rings, we have $\nu_z < 0$. In the weak-strong picture the dynamics of the single (test) particle in the weak beam is influenced by the strong beam, which is not affected at all. In the linear approximation the particle receives a kick at IP from the strong beam. This interaction is described by the matrix

$$M_{bb} = \begin{pmatrix} 1 & 0 & 0 & 0 \\ -4\pi\xi_0/\beta_y^0 & 1 & 0 & 0 \\ 0 & 0 & 1 & 0 \\ 0 & 0 & 0 & 1 \end{pmatrix}, \quad (6)$$

which contains the vertical (nominal) beam-beam parameter ξ_0 , viz., for Gaussian bunches:

$$\xi_0 = \frac{r_e}{2\pi\gamma} \frac{N\beta_y^0}{\sigma_y^0(\sigma_x^0 + \sigma_y^0)}, \quad (7)$$

N being the number of particles in the strong beam, r_e the classical electron radius, γ the relativistic factor, σ_y^0 the vertical beam size.

$$\sigma_y^0 = [\beta_y^0 \epsilon_y^0 + \eta_0^2 \epsilon_z^0 / \beta_z^0]^{1/2}, \quad (8)$$

ϵ_y^0 and ϵ_z^0 are the vertical and longitudinal emittances, and all quantities are evaluated at the IP.

Now, the complete revolution matrix with the beam-beam collision is:

$$M = M_{bb}^{1/2} M_{arc} M_{bb}^{1/2}. \quad (9)$$

4 CHANGE OF OPTICS

For the tunes, we can get the explicit form easily[7]

$$2 \cos \bar{\mu}_{\pm} = \cos \mu_y^0 + \cos \mu_z^0 - 2\pi\xi_0(\sin \mu_y^0 + \chi \sin \mu_z^0) \pm \sqrt{D}, \quad (10)$$

where

$$D = (\cos \mu_y^0 - \cos \mu_z^0 - 2\pi\xi_0(\sin \mu_y^0 - \chi \sin \mu_z^0))^2 + 16\pi^2 \xi_0^2 \chi \sin \mu_y^0 \sin \mu_z^0, \quad (11)$$

and

$$\chi = \frac{\eta_0^2}{\beta_z^0 \beta_y^0} \simeq \frac{\eta_0^2 \sigma_\delta}{\sigma_z^0 \beta_y^0} \quad (12)$$

is the synchrotron tune shift factor. The motion is stable if and only if $|\cos \bar{\mu}_{\pm}| \leq 1$ and $D \geq 0$.

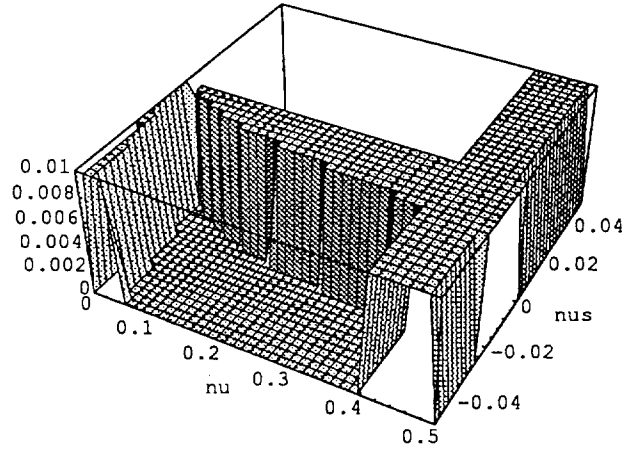

Figure 1: The (growthrate -1) at $\xi_0 = 0.05$, $\beta_y^0 = 0.1\text{m}$, $\beta_z^0 = 10\text{m}$ and $\eta_0 = 0.5\text{m}$ as a function of ν_y^0 and ν_z^0 .

To lowest order in ξ_0 , we get

$$\nu_y \rightarrow \nu_y + \xi_0, \quad \nu_z \rightarrow \nu_z + \xi_0 \chi. \quad (13)$$

A synchrotron tune shift is thus predicted due to the combined effect of η_0 and ξ_0 . The perturbative equation, Eq.(13), implies that the linear instability occurs for

- $\nu_y \lesssim$ half integers (betatron instability)
- $\nu_z \lesssim$ half integers (synchrotron instability).
- $\nu_z + \nu_y \lesssim$ integers (synchro-betatron instability).

The instability regions in the (ν_y^0, ν_z^0) plane is shown in Fig. 1, in terms of the growthrate. The three unstable regions stated above are clearly seen.

For other parameters, we get the exact values numerically. In particular, the change of η 's and ζ 's are of interest. At the middle of the IP, by symmetry reason, we have $\eta' = \zeta = 0$. In Fig.2, we show η as a function of ξ_0 . (When $\nu_z^0 \lesssim 0$, M can become unstable and we do not get η . Outside the instability region, the $\eta(\nu_z^0)$ is the same as $\eta(-\nu_z^0)$.)

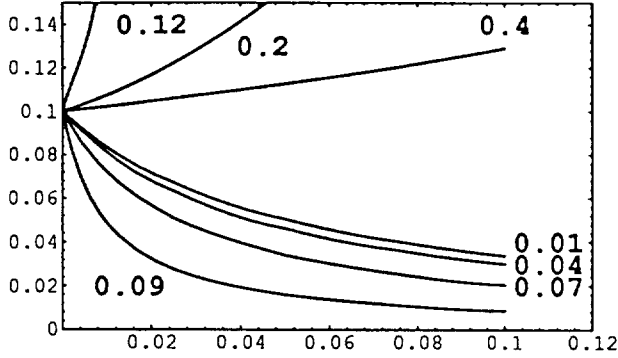

Figure 2: The dispersion η as a function of ξ_0 for several ν_z , with $\beta_y^0 = 0.1m$, $\beta_z^0 = 10m$, $\nu_y^0 = 0.1$, $\gamma_0 = 0.1m$. For $0 \leq \nu_z^0 < 0.01$, the curve is almost identical with that for $\nu_z^0 = 0.01$.

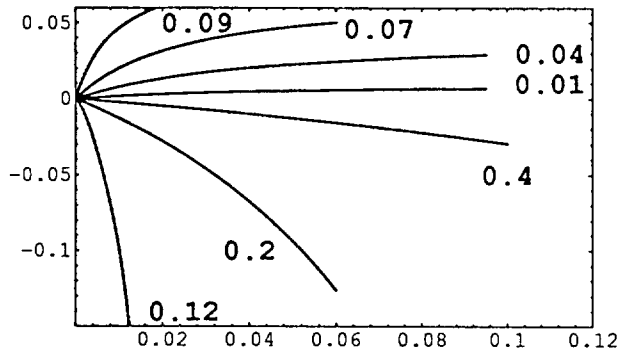

Figure 3: The ζ' as a function of ξ_0 for several $\nu_z^0 > 0$, all other parameters are the same as previous figure.

Here, we see clearly, how the dispersion depends on ν_z . In Ref.[4], the evaluation of D at the IP was done as follows:

$$D(\xi_0) = D(0)/[1 + 2\pi\xi_0 \cot(\mu_y^0/2)].$$

This formula does not show the dependence on ν_z^0 and agrees only with the curve in Fig.2 for $\nu_z^0 = 0$. The deviation of η from D is remarkable for $\nu_z^0 \simeq \nu_y^0$.

For ζ' , we show it in Fig.3 for $\nu_z^0 > 0$. We also see the remarkable growth of ζ' in particular for $\nu_z^0 \simeq \nu_y^0$. From Eq.(5), there seems to be a possibly dangerous growth of $\langle p^2 \rangle$ because of ζ' . Also from Eq.(5), the $\langle y\delta \rangle$ can be modified a lot which might affect the effective energy resolution of the monochromatic collision.

5 DISCUSSION AND CONCLUSION

Because of the synchrotron instability, $\nu_s = 0$ is one of the singular point of M . Thus, we should modify Eq.(4) as

$$\lim_{\nu_s \rightarrow 0^+} h = \begin{pmatrix} 0 & D \\ 0 & D' \end{pmatrix}.$$

The discussion based on D might be dangerous with synchrotron oscillations. As discussed in Ref.[7], D is a well

defined concept even with the presence of the synchrotron oscillation as long as $D = D' = 0$ in cavities. By the beam-beam insertion, however, this condition can be violated even if it was so before the insertion. In such a case, if one insists D , (s)he might fall into an unsolvable confusion. The (generalized) dispersion η is a natural extension of D which (with ζ 's) can work for general cases.

One might understand the change of ν_s as caused by the change of the momentum compaction factor α_m through the change of D all around the ring ($\alpha_m = \langle D/\rho \rangle$, ρ being the bending radius). It is similar to understanding the beam-beam tune shift ($\delta\nu_y$) as caused by the change of β_y all around the ring ($2\pi\nu = \int ds/\beta$), instead of looking at the eigenvalues. When the synchro-betatron coupling becomes large, in particular for the monochromatic collision, we can no longer use the traditional dispersion D which suited to the coasting beams and we should treat the optics more carefully and use more general formalism. There can be a factorization method of the the revolution matrix simpler and better than that discussed here. At least, however, it is unthinkable that we can treat coupled synchro-betatron oscillations with less parameters than the number of free parameters of the symplectic matrix (3,10, and 21 for 1d, 2d, and 3d problems).

6 ACKNOWLEDGEMENTS

The authors would like thank Dr. A. Piwinski for his kind communication to them and information on his early works on the dispersion effects. The Canon Foundation Europe is gracefully acknowledged for supporting S.P. during her stay at KEK as a Visiting Research Fellow. She also thanks the Members of the KEK Accelerator Theory Group for their hospitality and help. A part of this job was done when K.H. has been in the University of Salerno with the support of I.N.F.N. Salerno. He thanks I.N.F.N and the members of the "Dipartimento di Scienze Fisiche E.R. Caianiello" for hospitality.

7 REFERENCES

- [1] E.D. Courant and H.S. Snyder, Ann. Phys. 3, 1958, 1.
- [2] M. Sands, SLAC-121(1970).
- [3] A. Renieri, INF-75/6(R), February 1975.
- [4] A. Piwinski, DESY 77/18, 1977; A. Piwinski, DESY Internal Bericht, DESY H1/71-1 (1971).
- [5] J.M. Jowett, *Frontiers of Particle Beams: Factories with e+e- Rings*, eds. M. Denies, M. Month, B. Strasser, S. Turner, Springer Verlag, 1994; and references given in this paper.
- [6] K. Ohmi, K. Hirata and K. Oide, Phys. Rev., E-49, 1994, 751.
- [7] S.Petracca and K. Hirata, KEK Preprint 96-162 (1996).

