



Large Hadron Collider Project

LHC Project Report 154

**Thermohydraulics of Quenches and Helium Recovery
in the LHC Magnet Strings**

Maciej Chorowski, Philippe Lebrun, Luigi Serio, Rob van Weelderden

Abstract

In preparation for the Large Hadron Collider project, a 42.5 m-long prototype superconducting magnet string, representing a half-cell of the machine lattice, has been built and operated. A series of tests was performed to assess the thermohydraulics of resistive transitions (quenches) of the superconducting magnets. These measurements provide the necessary foundation for describing the observed evolution of the helium in the cold mass and formulating a mathematical model based on energy conservation. The evolution of helium after a quench simulated with the model reproduces the observations. We then extend the simulations to a full LHC cell, and finally analyse the recovery of helium discharged from the cold mass.

* LHC Division

*Presented at CHATS'97, San Francisco, USA
23-25 July 1997*

Administrative Secretariat
LHC Division
CERN
CH - 1211 Geneva 23
Switzerland

Geneva, 17 November 1997

Thermohydraulics of quenches and helium recovery in the LHC magnet strings

Maciej Chorowski, Philippe Lebrun, Luigi Serio, Rob van Weelderren
CERN - Division LHC, 1211 Geneva 23, Switzerland

keywords: magnet resistive transition, thermohydraulics, helium

In preparation for the Large Hadron Collider project, a 42.5 m-long prototype superconducting magnet string, representing a half-cell of the machine lattice, has been built and operated. A series of tests was performed to assess the thermohydraulics of resistive transitions (quenches) of the superconducting magnets. These measurements provide the necessary foundation for describing the observed evolution of the helium in the cold mass and formulating a mathematical model based on energy conservation. The evolution of helium after a quench simulated with the model reproduces the observations. We then extend the simulations to a full LHC cell, and finally analyse the recovery of helium discharged from the cold mass.

Introduction

CERN is preparing to build the Large Hadron Collider (LHC), a proton and ion collider with center-of-mass energy in the TeV-per-constituent range. This machine, to be installed close to Geneva (Switzerland) in the 26.7 km circumference tunnel of the existing LEP collider, will accelerate and bring into collision intense beams of protons and ions at higher energies than ever achieved before. This will allow to probe the structure of matter at the very fine scale of 10^{-19} m.

The LHC cryogenic scheme

The LHC will make intensive use of high-field, twin aperture superconducting magnets, operating in static baths of pressurized helium II at 1.9 K and at about 0.1 MPa, in which the generated or deposited heat load is transported by conduction to a heat exchanger tube threading its way along the magnet string - see Figure 1.

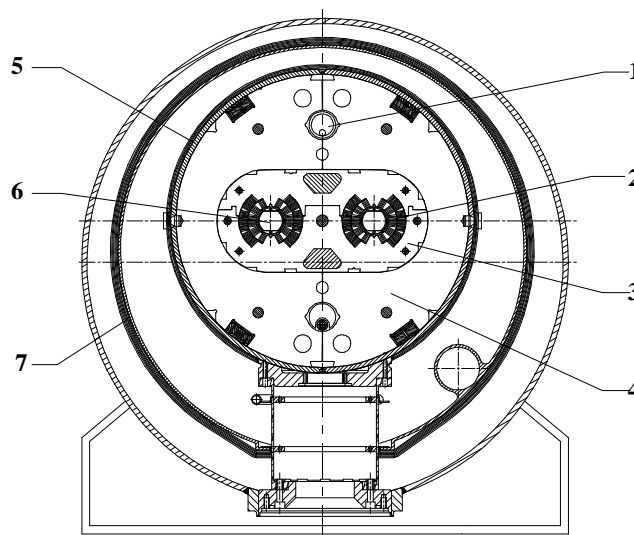

Figure 1. LHC main dipole cross section, 1 - heat exchanger tube, 2 - coil, 3 - aluminium collars, 4 - iron yoke, 5 - stainless steel cylindrical vessel, 6 - beam tube, 7 - thermal shield.

Inside the tube (1), a flow of saturated helium II absorbs the heat load from the cold mass by gradual vaporisation of the liquid phase in quasi isothermal conditions. This concept of cooling

is implemented in independent loops, each extending over 107 m - the length of two half-cells of the regular LHC lattice^{1,2} - see Figure 2.

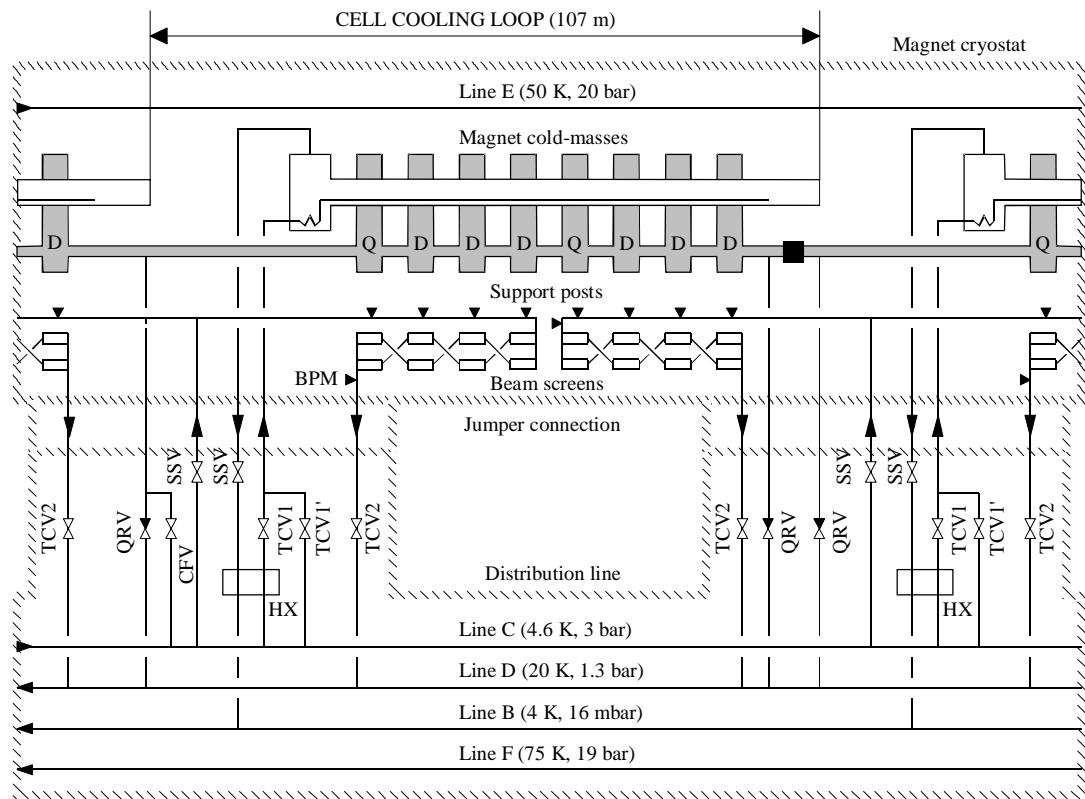

Figure 2. A simplified scheme of the LHC cell cooling loop, Q - quadrupole, D - dipole, QRV - quench relief valve, CFV - Cooldown-and-Fill Valve, TCV - temperature control valve, SSV - subsector valve, HX - heat exchanger

With the term “cold mass” we designate the ensemble formed by the coils (2), the aluminium collars (3) and iron yoke (4), the helium in which the whole is immersed and the stainless-steel vessel (5) around the assembly - see Figure 1.

The LHC cryogenic architecture is based on eight sectors (1/8 of the machine circumference), equipped with a cryogenic helium plant, each producing and distributing refrigeration over a length of 3400 m and across elevation differences of up to 44 m - see Figure 3². Each sector comprises 46 regular half-cells in the arc plus a number of special cryomagnets, arranged in strings thermohydraulically equivalent to a half-cell. For the analysis of the thermohydraulic consequences of a quench the whole sector will be taken as composed of 54 equivalent half-cells.

Magnet quenches and helium recovery

The magnetic energy stored in the magnets forming a LHC half-cell, will be released to the cold mass during a resistive transition (quench) and may be as high as 22.1 MJ¹. The extremely high magnetic energy density coupled with relatively slow propagation speed of the resistive transition requires the use of quench heaters thermally coupled to the outer layer of the magnet coil. This spreads the energy throughout a large volume of the winding within a few tenths of a second following a quench detection. The quenched magnet is then by-passed by a cold silicon diode situated in the magnet cryostat and the remaining series-connected unquenched magnets are de-excited. The energy dissipated in the coils by ohmic heating eventually ends up in the

magnet cold mass. To avoid a pressure rise in the cold mass beyond its 2 MPa design pressure, a quench relief valve QRV must be opened to allow the helium to be discharged to line D (see Figure 2).

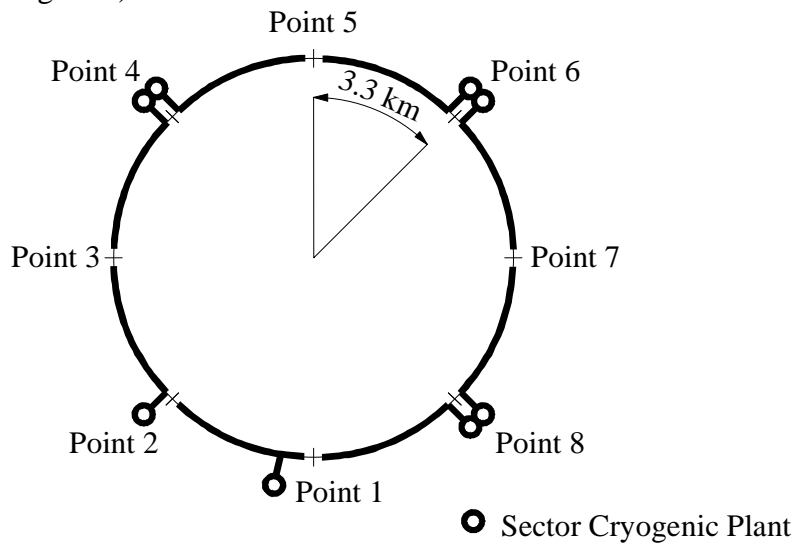

Figure 3. Schematic of the LHC cryogenic sectorization

In the design and prototyping phase of the LHC, the following crucial safety and helium recovery elements must be adequately sized and configured:

- quench relief valves, to discharge safely the cold mass helium after a quench,
- volume and mechanical properties of helium recovery vessels and pipelines (line D and dedicated medium-pressure tanks), to preserve helium inventory and if possible recover its refrigeration capacity,
- mechanical resistance of the cryostat, to withstand the pressure peak after a quench.

The sizing and configuration of the above elements requires a good understanding of the quench thermohydraulics and physical processes involved, as well as reliable input data for process modelling.

The prototype magnet string

In preparation for the LHC project, a 42.5 m-long prototype superconducting magnet string, representing a half-cell of the machine lattice, has been built and operated. Figure 4 shows the schematic of the cryogenic configuration of the prototype string. It comprises one quadrupole magnet (Q) and three dipole magnets (D), a cryogenic feed box (SFB) on the left end, and a return box (SRB) on the right end. The string is mounted on a slope of 1.4%, corresponding to the maximum slope that will be encountered in the LHC machine tunnel. The magnets normally operate in a pressurized static bath of superfluid helium at a pressure of 0.1 MPa and temperature of 1.9 K. The liquid helium content in the cold mass is about 20 l/m, which amounts to a total inventory of 850 l. At 13.1 kA the magnets have 15.3 MJ of energy stored in their magnetic field. The four magnets in the string form a single hydraulic unit. In case of an over-pressure the helium can escape via a quench relief valve, mounted at the upper part of the rightmost dipole magnet. The helium is then discharged into the cold line D (20 K, 1 bar), then into an isolated quench buffer vessel and finally into a warm storage balloon. The remaining circuits are used for cool-down, 1.9 K temperature control, and cryostat heat intercepts. The string cryogenic system is described in detail in references^{3,4}.

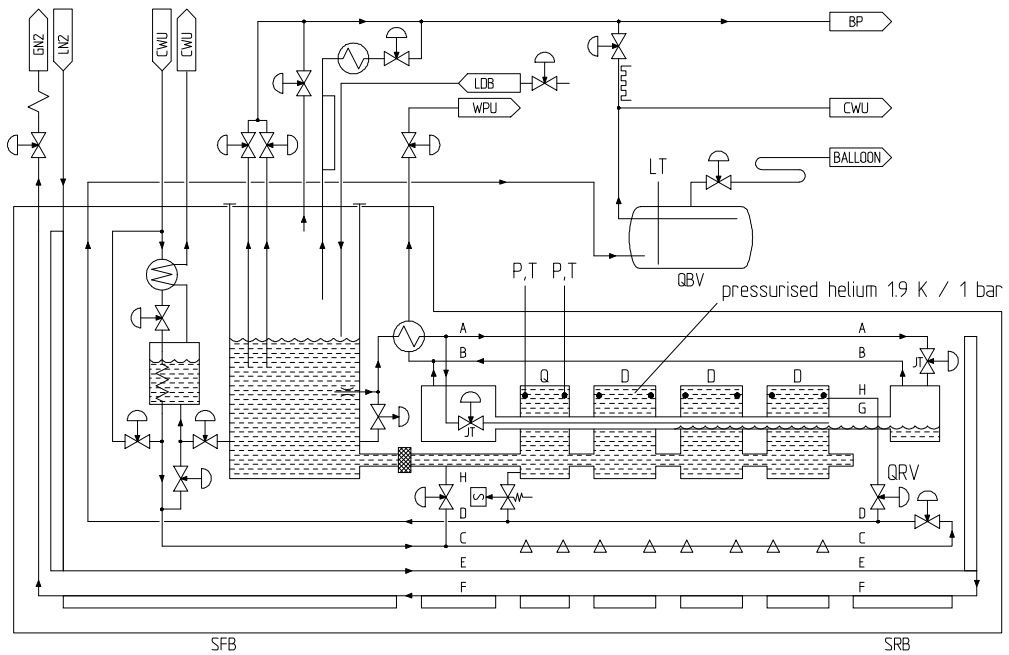

Figure 4. Simplified cryogenic flow scheme of the prototype magnet string, Q - quadrupole, D - dipole, QRV - quench relief valve, P,T - pressure and temperature sensors, SFB - cryogenic feed box, SRB - cryogenic return box

Prior to their mounting in the string, each magnet has been quench-tested separately in stand-alone configuration⁵. Temperatures were measured in the end volumes and at midlength in the collar and yoke. Pressures were measured in the end volumes, and at three locations along the length of the magnet in the collars. These measurements showed that the pressure development after a quench is homogenous over the bulk of the magnet. Therefore the string is equipped with pressure and temperature sensors located in the cold mass end volumes only.

Evolution of the helium thermodynamic state after a quench of the prototype string

Figures 5 and 6 show the measured development of the helium in the string cold mass after a 13.1 kA quench. In the phase diagram of Figure 5 the helium starts at 1.9 K, 1 bar, it then evolves steeply up (within about 150 ms) in pressure to about 12 bar, but remains roughly at the same temperature. Then the quench relief valve opens, the pressure drops to about 4 bar and the temperature gradually increases. Later, the helium in the string cold mass evolves in the supercritical region.

Process identification

The observations presented in Figures 5 and 6 have led us to identify two main processes, each acting on a different time scale, which govern the helium thermohydraulics after a quench⁶. On a short time scale (referred later as phase 1), up to about 150 ms after a quench, the cold mass helium is adiabatically compressed. This follows directly from the measured evolution of the helium in the phase diagram (see Figure 5) as compared with ideal lines of evolution for isochoric heating, and adiabatic compression (Figure 7).

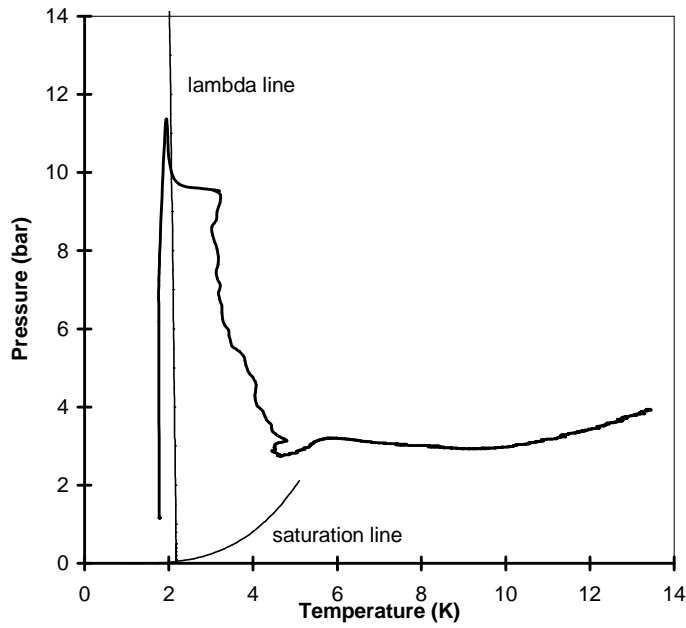

Figure 5. Measured phase diagram of the string cold mass helium after a 13.1 kA quench

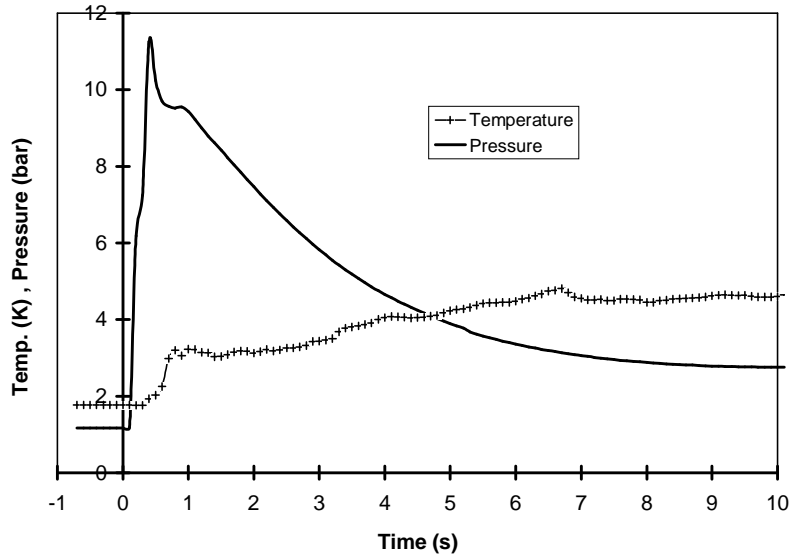

Figure 6. Measured development of the string cold mass after a 13.1 kA quench, quench heaters fired at 0 s

The adiabatic compression does not involve any mass transfer, it propagates with the speed of sound. It is therefore not possible to limit the peak pressure by any means of fast discharge. This has been confirmed on the prototype string by a series of tests with different delay time of quench relief valve opening. The valve opening time was varied from 110 to 220 ms, with an additional measurement at “0 ms” when the quench relief valve was opened before triggering a quench - see Figure 8. The influence of helium discharge on the peak pressure is weak, and becomes appreciable only for opening delay times greater than about 100 ms.

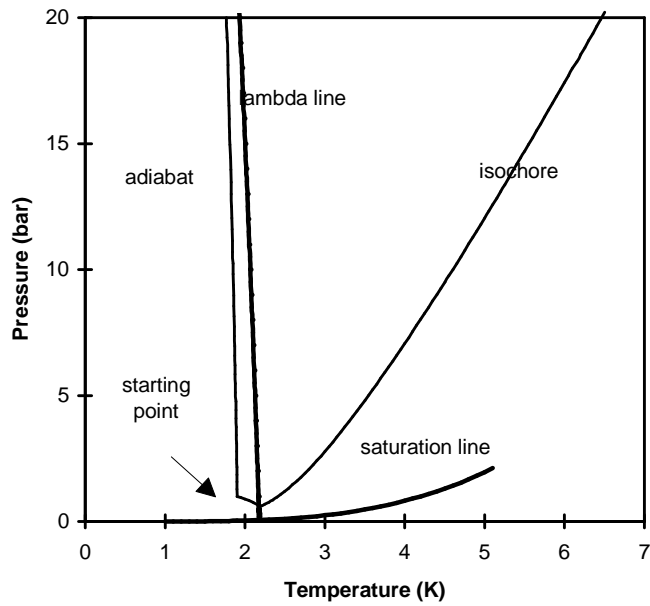

Figure 7. Ideal lines of evolution for isochoric heating and adiabatic compression of helium⁶

On a longer time scale (referred later as phase 2), up to about 2 minutes after a quench, the helium is heated, while simultaneously being allowed to discharge from the cold mass.

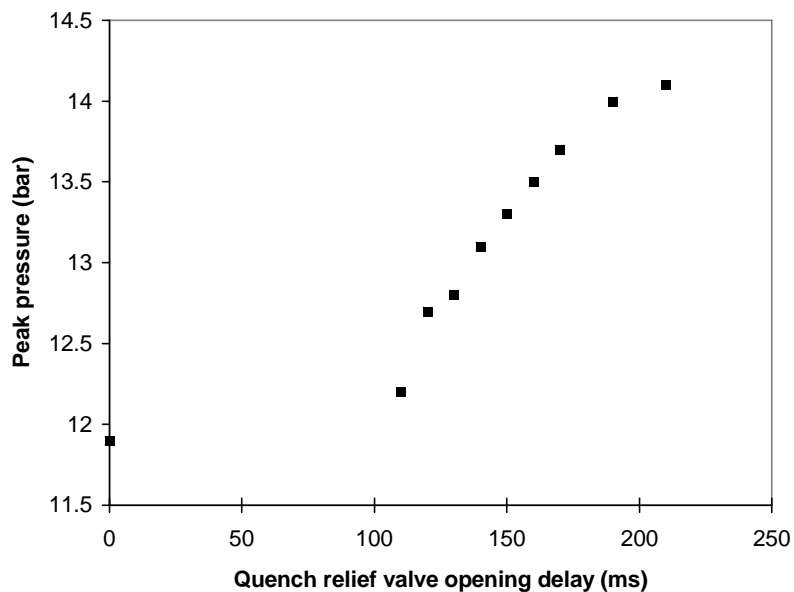

Figure 8. Measured for the prototype magnet string pressure peak dependence on quench relief valve opening delay time

Process modelling

The fact that the pressure over the bulk of the helium is homogenous, justifies the lumped parameter approach which we have used for modelling quench thermohydraulics.

In principle, one should expect more precise numerical results from distributed models, i.e. taking into account dynamic effects; however, such models require the introduction of many experimental coefficients, which may be difficult to estimate experimentally.

The lumped approach neglects the dynamic effects, but is based on simple physical laws and needs very few experimental coefficients. The leading equation is the energy balance of the helium in the cold mass (1):

$$dU = dQ + \sum_i h_i dM_i - p dV , \quad (1)$$

where U is internal energy; Q is heat transferred to helium; h is enthalpy per unit mass; M is mass of helium; p is pressure; V is volume.

As follows from equation (1), the processes of heat transfer, helium flow and work are considered sufficient to generate the model description of the thermohydraulics transients after a quench of the magnets.

For the purpose of our analysis, we will consider the very general thermohydraulic scheme of a superconducting magnet immersed in a pressurized helium bath, presented in Figure 9.

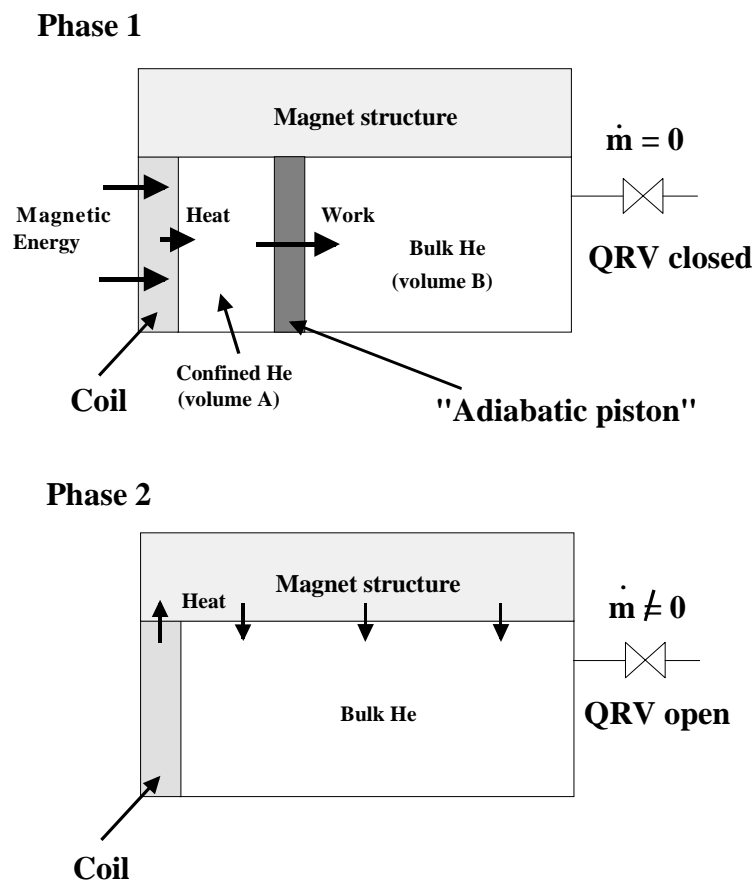

Figure 9. Thermohydraulic scheme of a superconducting magnet in a pressurised helium bath, Phase 1 - adiabatic compression of the bulk helium, Phase 2 - bulk helium heating and discharge

Phase 1 - adiabatic compression of the bulk helium

Consider the cold mass helium as split into two connected volumes (Phase 1): the bulk helium (volume B) and the moderately “confined” helium which fills cable voids and the vicinity of the cable, e.g. the space between the coils and the collars (volume A). The two helium volumes are separated by a virtual adiabatic piston being the moving interface between them (no mixing). The confined helium is in close thermal contact with the magnet coil and its amount can

be estimated on the basis of superconducting cable compaction and winding geometry. Magnet collars and yokes are immersed in the bulk helium (volume B).

The analysis assumes a uniform quench of the whole winding and the dissipation of the stored magnetic energy within a few tenths of a second.

During the first milliseconds after a quench the heat originating from the dissipated magnetic energy is still concentrated in the magnet coils. The coils exchange heat efficiently only with the confined helium in volume A. This helium would attain very high pressures if not given the possibility to expand, thereby compressing adiabatically the bulk helium by means of the virtual piston.

Phase 2 - discharge

Rapid evaporation and change of phase of the expanded helium, initially confined in the volume A, cause a decrease in heat transfer between the coil and the helium. The pressure reaches its peak value and the adiabatic compression of the bulk helium ends.

After the adiabatic compression has ended, the expanded helium and the compressed bulk helium mix, the pressure thereby drops from its peak value down to a few bar and the temperature increases by about 2 K (compare Figure 5). At the same time the heat dissipated in the coils is gradually being transferred by solid conduction to the collars and yoke (magnet structure). In this way the bulk helium gets exposed to an increasingly larger heat exchange area. At this stage we consider the magnet structure as the heat source for the bulk helium. The helium warms up and pressurises at a rate low enough to maintain its pressure below the cryostat design limits, thanks to the discharge through a quench relief valve - see Figure 9, Phase 2.

Input data and leading equations

The following set of input data is used to calculate the peak helium pressure and pressure evolution in the cold mass after a quench:

1. total amount of cold mass helium M and its initial conditions T_i, p_i before the quench,
2. confined volume fraction x ,
3. coil temperature T_{coil} after the ohmic dissipation of the magnetic energy,
4. temperature difference ΔT between the coil temperature T_{coil} and the confined helium temperature T_{He} ,
5. heat flux \dot{q} from the magnet structure to the cold mass helium during the discharge phase.

The coil temperature T_{coil} can be estimated by making an adiabatic approximation: it is considered, for the quenching volume, that no heat transfer to helium nor heat conduction to the neighbouring regions occur. As will be shown later, the amount of heat transferred to the confined helium during the adiabatic compression is less than 2 % of the dissipated magnetic energy, which justifies the adiabatic approximation.

Phase 1

The peak helium pressure can be calculated from Equations (2 - 4) and the helium equation of state⁷.

Equation (2) below expresses the energy balance of the fraction x of the confined helium after a quench, where W is the work of adiabatic compression of the bulk helium and ΔQ is heat transferred to the confined helium from the magnet coils.

$$M \cdot x \cdot (u(T_{He}, p_2) - u(T_i, p_i)) = \Delta Q - W, \quad (2)$$

$$W = (1 - x) \cdot (u(p_2, s_1) - u(p_i, s_1)), \quad (3)$$

$$T_{He} = T_{coil} - \Delta T \quad (4)$$

Figure 10 shows the calculated relation between the peak pressure and the expanded helium temperature, taking the confined helium fraction x as parameter.

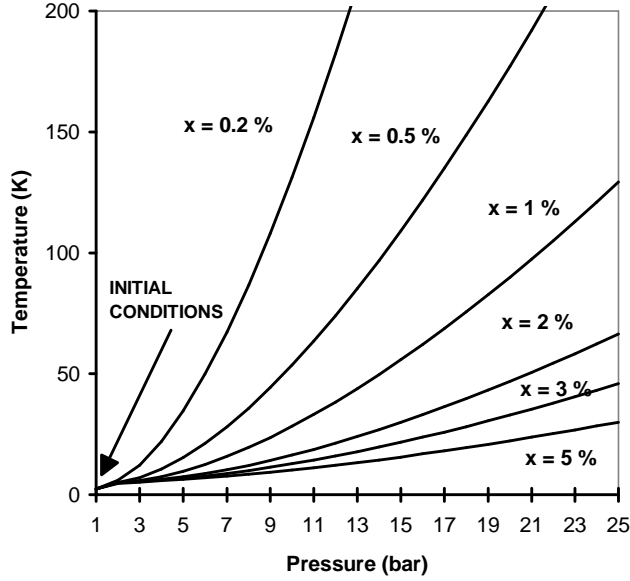

Figure 10. Calculated helium temperature and pressure after an adiabatic compression of the bulk helium, x - fraction of the confined helium

If no experimental data were available, a temperature difference ΔT of zero could be conservatively assumed as a first estimate. However as Figure 10 shows, the peak pressure is very sensitive to the temperature of the expanded helium. As a consequence the conservative assumption above can lead to significant overestimation of the pressure.

For the magnets in the prototype string, the maximum coil temperature after a 13.1 kA quench, calculated using the adiabatic assumption, is about 140 K. We have estimated from micrographs of coil cross-sections, a confined helium fraction x of 2 %. Assuming that the expanding helium follows exactly the coil temperature, the peak pressure would attain a value exceeding by more than twice the experimental results (compare Figures 6 and 10). To obtain calculated values of peak pressure of about 12 bar, in agreement with the measurements, we have set the temperature difference at about 110 K. This corresponds to a heat transfer coefficient between the coil and the expanding helium of the order of a few W/cm^2 .⁸

Phase 2

We consider then the simultaneous onset of helium mixing and discharge from the cold mass. The cold mass helium evolution can be now calculated from equation (6):

$$dU_{\text{He-cold-mass}} = \dot{q} \cdot dt + h \cdot \dot{m} \cdot dt, \quad (6)$$

where, for a one-phase flow of the supercritical helium discharged through the quench relief valve:

$$\dot{m} = C \cdot k_v \cdot \sqrt{\Delta p \cdot \rho} \quad (7)$$

where C is a conversion factor, \dot{q} is the heat flow to the helium from the magnet structure during discharge, k_v is the flow coefficient of the quench relief valve, ρ is helium density in the cold mass and Δp is the pressure drop at the valve.

We have used experimental data from the prototype magnet string, to estimate:

- the heat flux \dot{q} from the magnet structure to the cold mass helium,
 - the flows of enthalpy, $\dot{h}(t)$, and mass, $\dot{m}(t)$, of helium leaving the cold mass,
 - the final distribution of the magnetic energy released after a quench, among cold mass, helium left in the cold mass and helium expelled from the cold mass to the recovery line.
- We have measured the helium temperature and pressure in the cold mass end volumes and the pressure drop at the quench relief valve (see Figure 4).

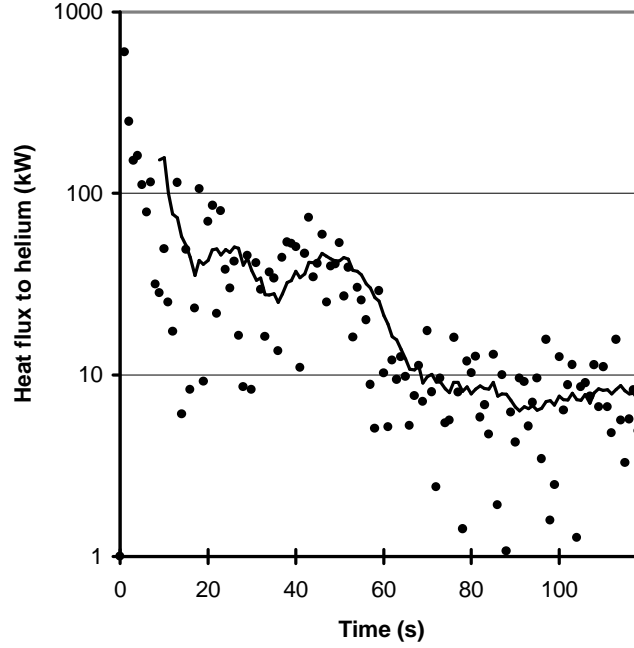

Figure 11. Heat flux to the cold mass helium after a 13.1 kA quench during the discharge phase of the prototype string (measured)

Figure 11 shows the estimated heat flux from the magnet structure to the helium in the cold mass after a quench. In the discharge phase the temperature readouts were characterised by noisy fluctuations (compare with Figure 5) which resulted in dispersion in the heat flux assessment. The average heating power is high in the phase of adiabatic compression of the bulk helium and reaches about 800 kW. It then decreases by about an order of magnitude for the next 60 seconds. Subsequently it tends toward zero.

Figures 12 and 13 show the measured helium enthalpy and mass flow as measured during discharge from the string cold mass. For energy balance purpose, an average helium enthalpy of 32 J/g can be calculated from Eq. (8).

$$\bar{h}_{He} = \int_0^{\infty} h(t) \dot{m}(t) dt / \int_0^{\infty} \dot{m}(t) dt \quad (8)$$

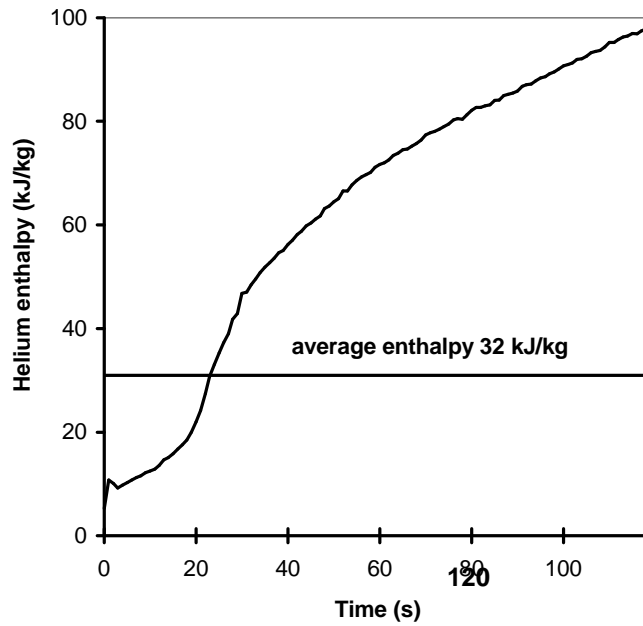

Figure 12. Enthalpy of helium leaving the cold mass after a 13.1 kA quench of the prototype string (measured), 120 s - end of discharge

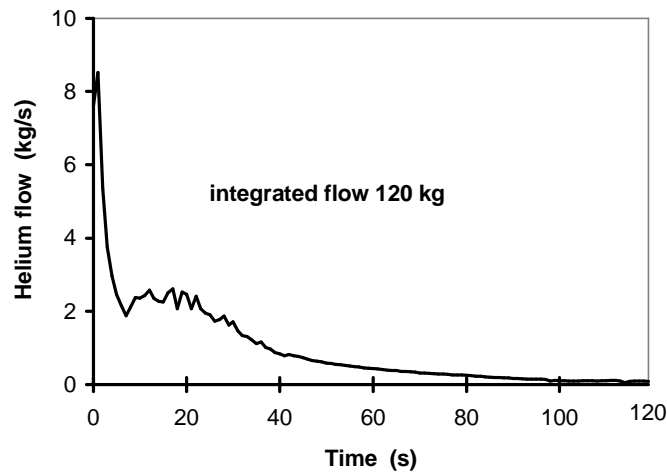

Figure 13. Helium mass flow out of the cold mass after a 13.1 kA quench of the prototype string (measured)

Table 1 gives the final magnetic energy distribution averaged over eleven 13.1 kA quenches of the prototype string.

Table 1. Measured energy balance following full current quench of the prototype string.

	Energy , MJ	Energy , %
Energy transferred to the helium expelled from the cold mass	3.8	25
Energy transferred to the cold mass	10.0	65
Energy transferred to the helium left in the cold mass	1.5	10
Coil magnetic energy	15.3	100

The initial conditions of helium temperature, pressure and enthalpy were respectively 1.9 K, 100 kPa and 1864 J/kg. The cold mass temperature was measured 30 minutes after a quench. Based on these data, an average helium enthalpy of 33 J/g can be calculated from Eq. (9), on the assumption that the process of heat transfer to the helium expelled from the cold mass is isobaric. This value is in good agreement with the value of 32 J/g obtained independently from Eq. (8). It confirms the validity of the helium mass flow $\dot{m}(t)$ estimation based on Equation 7.

$$\bar{h}_{He} = (h_{He-ini} \Delta M_{He-ex} + \Delta E_{He-ex}) / \Delta M_{He-ex} \quad (9)$$

where h_{He-ini} is the initial enthalpy of helium, ΔM_{He-ex} is the mass of helium expelled from the cold mass, ΔE_{He-ex} is the energy transferred to the helium expelled from the cold mass.

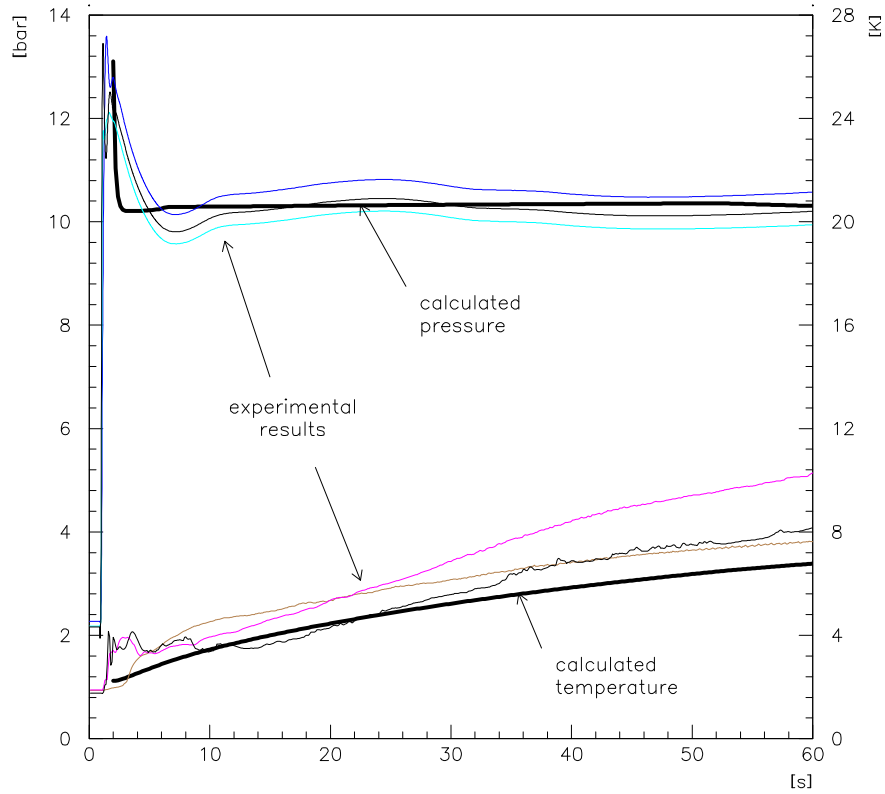

Figure 14. Measured and simulated evolution of the string cold mass helium after a 13.1 kA quench; the quench relief valve operates as a pressure-regulating device set to 10 bar.

The comparison of measured and simulated helium evolution after a quench of the prototype string is shown in Figure 14. The input data for the simulation are as in Figures 11 - 13, and the quench relief valve operates as a pressure-regulating device set at 10 bar.

Thermohydraulical behaviour of the LHC as predicted by the model

Simulation of the LHC full-cell discharge after a quench

The described approach has been used to assess the feasibility of discharging a full LHC cell (107 m) via a single quench relief valve and to find the required k_v coefficient of the valve⁸. The LHC dipoles will differ from those mounted in the prototype string. They will be longer (magnetic length of 14.2 instead of 9.7 m) and the stored magnetic energy will be higher (44.2 MJ instead of 30.6 MJ for a full-cell). Since the energy ratio (44.2 MJ/30.6 MJ) is similar to the dipole length ratio (14.2m/9.7m) the ratio of energy to cold mass will remain about the same. The distribution of helium in the cold mass remains unchanged, at about 20 l/m. The foregoing makes us confident that the final magnetic energy distribution between helium and magnet structure after a quench will be similar in both cases (see Table 1). The input heat flux to helium for the simulation is as shown by the trendline in Figure 11, multiplied by dipole length ratio of 1.46.

Figure 15 shows the calculated transients after a quench of a LHC full-cell. The simulation assumes that the helium is discharged via a quench relief valve with a k_v coefficient of 30, and operating as a pressure-regulating device set at 12 bar. A constant counter-pressure of 6 bar has been taken in the recovery line. Input data and model output are given in Table 2.

Table 2. Input data and model output for a full LHC cell discharge simulation.

Input data		Model output	
1.Magnetic energy	44.2 MJ	1.Peak pressure	130 kPa
2.Amount of the cold mass helium	314 kg	2.Heat transferred to the confined helium during adiabatic compression	656 kJ
2.Maximal coil temperature	140 K	3.Work of adiabatic compression	
3.Temperature difference	110 K		
4.Fraction x of the confined helium	2 %		128 kJ

The heat transferred to the expanding helium during the adiabatic compression of the bulk helium forms about 1.5 % of the dissipated magnetic energy, in conformity with the assumption concerning the adiabaticity of the coil temperature calculations.

The simulation confirms that a 107-m long LHC full-cell can be discharged safely, when a fraction of about 25% of the stored magnetic energy is transferred to the helium bath after a quench. It has also been decided for the LHC, to operate with quench relief valves acting as pressure-regulating devices, thus avoiding the need for active opening on the quench trigger.

Helium recovery after a quench

The purpose of helium recovery after a quench is the preservation of its inventory and if possible, the recovery of its refrigeration capacity. As shown conceptually in Figure 16, the recovery system for one LHC sector will consist of the following nodes:

1. 54 half-cells (1),
2. quench relief valves (2),
3. a vacuum-insulated line D (3) having a length of about 3400 m and volume of 60 m³ per sector, connected via quench relief valves (2) to the LHC half-cells (1),
4. an uninsulated vertical line (4) having a length ranging from 42 to 145 m, depending on the sector, connecting line D (3) via valve (4a) to medium-pressure gas storage tanks (5),
5. medium-pressure (2 MPa) gas storage tanks (5) with a volume of 250 m³ each, forming a quench buffer volume of 2000 m³,
6. piping and auxiliaries (6) interconnecting the system with the sector refrigerator.

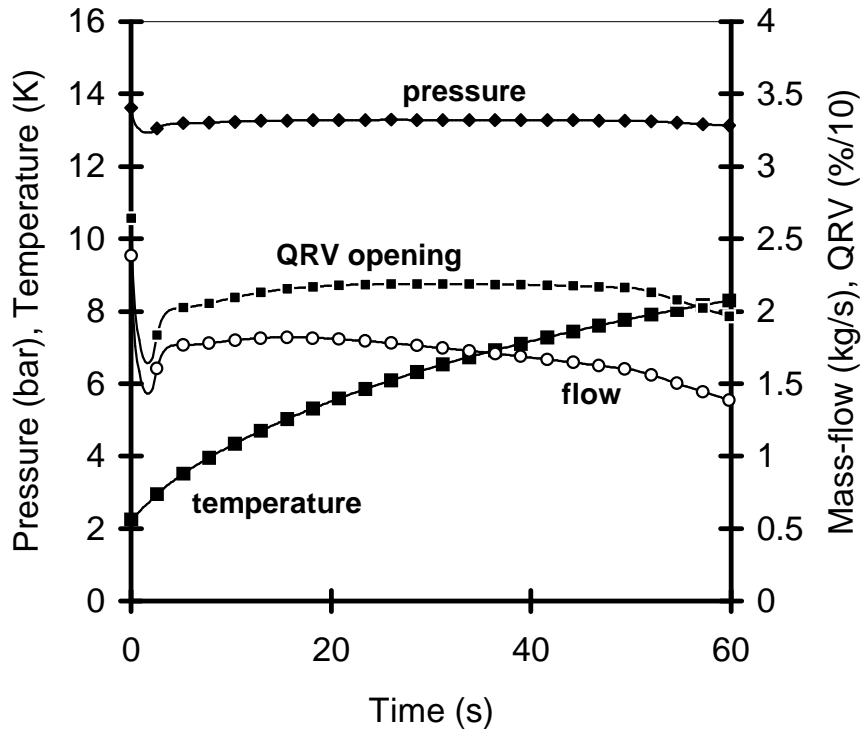

Figure 15. Helium evolution after a LHC cell quench (simulated)

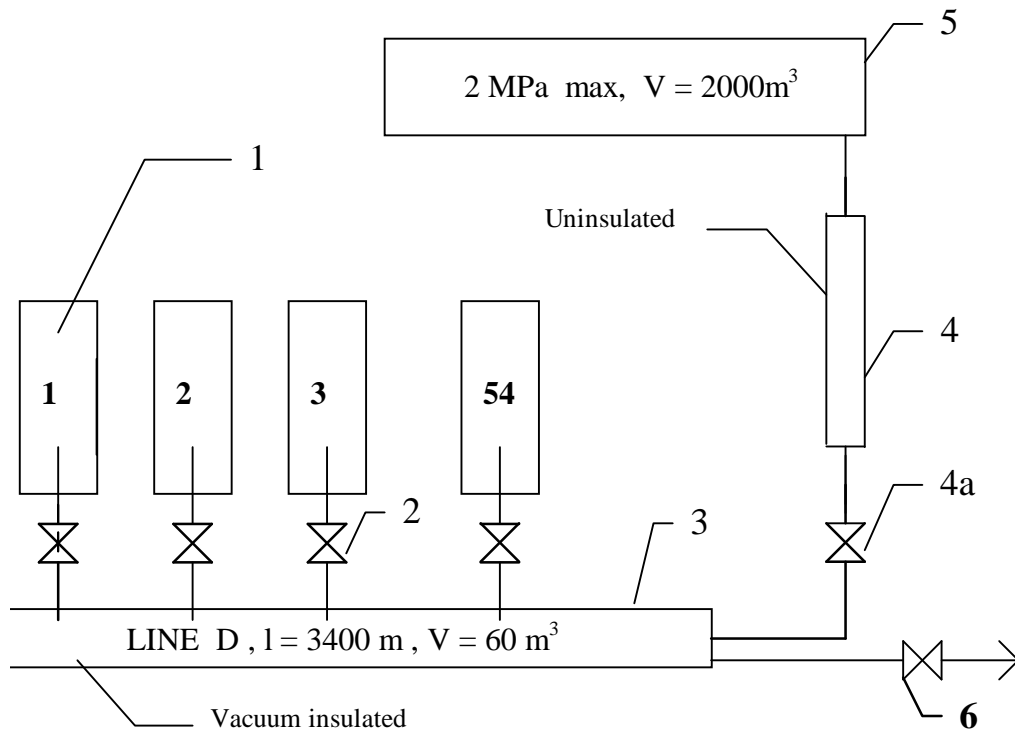

Figure 16. Helium recovery system, scheme for one sector, 1 - cryogenic half-cells, 2 - quench relief valves, 3 - vacuum insulated line D, 4 - uninsulated vertical line, 5 - medium-pressure gas tanks, 6 - auxiliaries

Calculation of the helium state in line D after a quench

We use helium enthalpy, $\dot{h}(t)$, and mass, $\dot{m}(t)$, flows as shown in Figures 12 and 13 as an input to calculate the thermodynamic state of helium in line D after a quench. The heat capacity of line D is negligible in comparison to that of the helium. Therefore for a given number n of half-cells quenched, equation (1) applied to the helium in line D takes the form:

$$dU = n \cdot \dot{h}(t) \cdot \dot{m}(t) dt \quad (10)$$

From the LHC operation point of view, there are two probable sizes of quenches to be considered:

- Limited quench - starting in one magnet and propagating to the adjacent magnets (up to 8 half-cells involved). A limited quench is considered as a normal occurrence in the course of collider operation.
- Whole sector quench - all sector magnets quenching simultaneously (46 - 54 half cells involved). A whole sector quench is considered as an accidental mishap in collider operation.

The calculated time evolution of helium temperature and pressure in line D after a 54 half-cell (whole sector) and 8 half-cell (limited) quench, is shown in Figures 17 and 18.

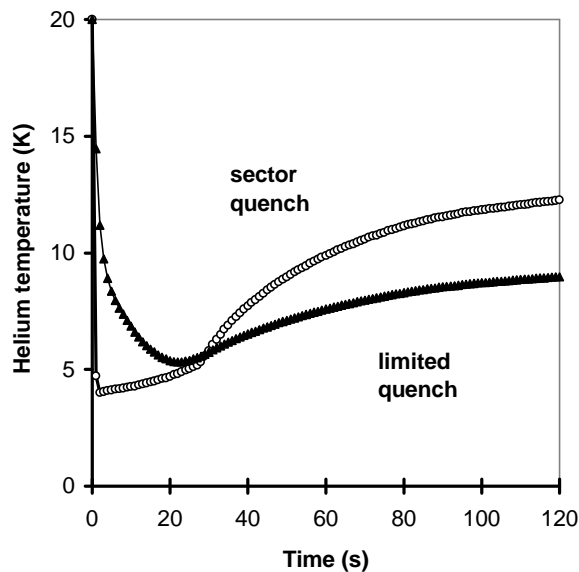

Figure 17. Temperature in line D after a quench (calculated)

Steady-state thermodynamic parameters of helium in line D

The thermodynamic parameters of helium in line D will reach steady state several minutes after a quench. The temperature and pressure will then depend on the number of half-cells quenched, with the enthalpy \bar{h}_{He} and mass of the discharged helium from one half-cell ΔM_{He-ex} as parameters - see Figure 19 and 20. The pressure in line D is limited to 2 MPa, as it was designed for, and established by previous work⁹. Line D forms a buffer which can accumulate expelled helium if the number of half-cells involved does not exceed 44.

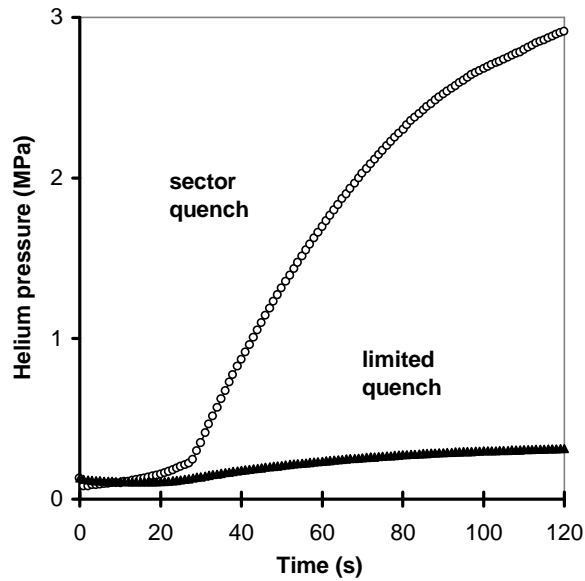

Figure 18. Pressure in line D after a quench (calculated)

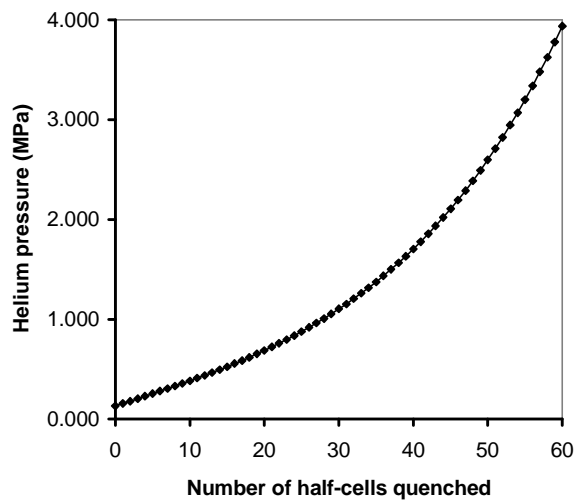

Figure 19. Calculated temperature in line D as a function of the number of half-cells quenched; average enthalpy of the discharged helium is 33 J/g, mass of helium discharged from one half cell is 120 kg.

Therefore, in case of a limited quench, line D can fully buffer the helium discharge from the LHC cold mass. Both helium inventory and its refrigeration capacity are recovered then. In case of a sector quench, a fraction of the expelled helium (up to 30%) must leave line D, be warmed up, and stored in the medium-pressure gas tanks. The temperature of helium leaving line D is below 12 K and the fluid is characterised by high cooling capacity which will be lost during warm up. As the sector refrigerator will be ready to accommodate the blow-down from vacuum insulated line D about 10 minutes after the quench, the line will have to store the remaining

helium for that period of time. After a sector quench it will then be possible to recover all the helium inventory, and at maximum about 70% of its cooling capacity.

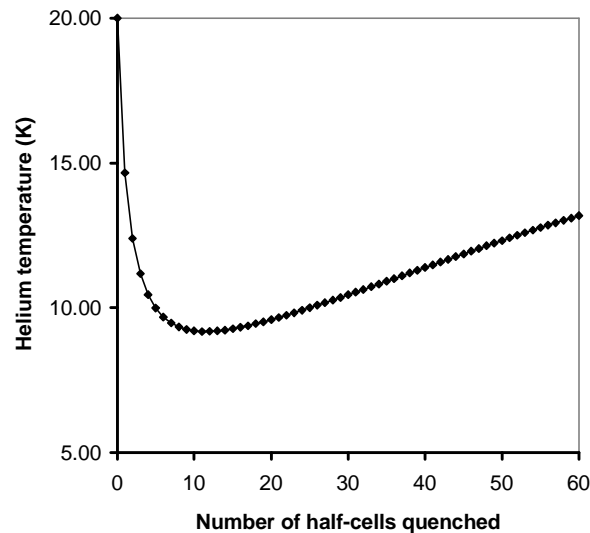

Figure 20. Calculated pressure in line D as a function of the number of half-cells quenched; average enthalpy of the discharged helium is 33 J/g, mass of helium discharged from one half cell is 120 kg.

Helium recovery in medium-pressure gas tanks

As follows from the calculation of the helium parameters in line D following a quench, only in case of a whole sector quench the capacity of line D becomes too small to contain (even for a short time) all the helium expelled from the cold mass, and a fraction of helium must be stored in the medium-pressure tanks (see Figure 16). The medium-pressure tanks are made of carbon steel, which constrains the temperature of the wall to be higher than -40°C . This means that the in-flowing helium stream must be warmed up. We have considered convective heating on the vertical line connecting line D with the medium-pressure gas tanks, and heat capacity of the tanks (see Figure 16), as two convenient passive sources of heat.

Figure 21 shows the temperature of helium inside the tank and of the tank wall, calculated for the following conditions:

1. The total quench buffer volume is 2000 m^3 and its heat capacity is 203 MJ/K.
2. The initial helium temperature is 253 K and initial pressure is 100 kPa.
3. Line D is discharged through a valve opening on pressure and set at 1 MPa, the integrated helium flow to the medium-pressure tanks after a whole sector quench is 2340 kg, maximal instantaneous flow is 20 kg/s, and the time evolution of helium temperature and pressure in line D is as given in reference¹⁰.
4. The convective heating power on the vertical uninsulated line is estimated at 17 kW.
5. The heat transfer coefficient between tank wall and helium is estimated at $58\text{ Wm}^{-2}\text{K}^{-1}$.
6. The heat transfer coefficient between the tank wall and ambient air is estimated at $10\text{ Wm}^{-2}\text{K}^{-1}$.
7. Ideal mixing of helium occurs inside the tanks and no temperature gradient exists across the tank wall.

The temperature of the tank wall decreases by 8 K only, reaching 245 K, and it remains well above its lower limit (233 K). The tank heat capacity is high enough to warm up the in-flowing helium and to prevent the tank wall from dangerous subcooling, with a comfortable safety margin. It must however be stressed that the heat capacity of the tanks can be exploited to its full

extent only if good mixing of helium inside the tanks is achieved, e.g. by use of an appropriate tank inlet pipe-work, preventing jet formation and spot cooling of the tank wall.

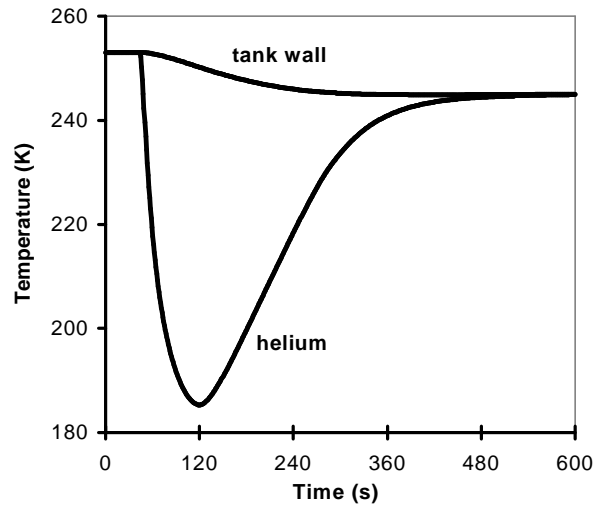

Figure 21. Calculated wall and helium temperature in medium-pressure tank during discharge of line D, initial temperature and pressure 253K and 1 bar respectively

Conclusions

1. As long as the magnet design guarantees pressure homogeneity after a resistive transition by allowing a sufficient radial venting, the quench thermohydraulics can be depicted by a two-volume model, where the bulk of the helium and the moderately confined helium in the coils and in their vicinity are separated by a virtual adiabatic piston. The two-volume model will evolve to a single volume model once the confined helium has expanded and the helium discharge has started.
2. The thermohydraulics of resistive transitions of the LHC prototype magnet string is governed by two main processes: initially a fast adiabatic compression of the bulk of the helium by the rapidly expanding confined helium, and later a global convective heating of the bulk helium accompanied by the helium discharge. The transition between these processes is formed by mixing between the expanded helium and the compressed bulk helium.
3. The initial pressure peak due to the adiabatic compression of the bulk helium is inherent to the magnet design and cannot be reduced by any means of fast discharge.
4. The quench pressure developments can be simulated with sufficient accuracy to justify, for design purposes, the use of the lumped parameter approach for configuring and sizing the LHC quench relief valves and helium recovery system.
5. For any magnet, hydraulically similar to the LHC dipole, a first conservative assessment of the peak pressure and thermohydraulic transients after a quench is possible, prior to any experimental evidence. This assessment may overestimate the maximum pressure by a factor of about two. For a more precise validation of the cryogenic consequences of a quench, a single series of experiments performed on a prototype magnet or a prototype string of magnets should be sufficient. These results remain valid as long as the fraction x of the confined helium and the heat transfer from the magnet structure to the helium remain unchanged.

References

1. The Large Hadron Collider, Conceptual Design, Eds. P.Lefevre, T.Petterson CERN/AC/95-05 (LHC), CERN Desktop Publishing Service, October 1995
2. M.Chorowski, W.Erdt, Ph. Lebrun, G.Riddone, L. Serio, L.Tavian, U. Wagner and R. van Weelderren, A Simplified Cryogenic Distribution Scheme for the Large Hadron Collider, paper presented at the CEC 97 conference, Portland, 1997
3. A. Bézaguet, J. Casas-Cubillos, B. Flemsaeter, B. Gaillard-Grenadier, Th. Goiffon, H. Guinaudeau, Ph. Lebrun, M. Marquet, L. Serio, A. Suraci, L.Tavian and R. van Weelderren, The Superfluid Helium Cryogenic System for the LHC Test String: Design, Construction and First Operation, *Advances in Cryogenic Engineering*, Vol. 41 (1996), p. 777
4. A. Bézaguet, J. Casas-Cubillos, H. Guinaudeau, B. Hilbert, Ph. Lebrun, L. Serio, A. Suraci and R. van Weelderren, Cryogenic Operation and Testing of the Extended LHC Prototype Magnet String, *Proc. ICEC 16/ ICMC*, Kitakyushu, Japan, 1996
5. G.Gerin, B.Vullierme and R. van Weelderren, Measurement of the Thermohydraulic Behaviour of LHC Dipole Prototypes after a Quench, *Advances in Cryogenic Engineering* Vol. 41 (1996), p. 811
6. M. Chorowski, B. Hilbert, L. Serio and R. van Weelderren, Thermohydraulics of Resistive Transitions of the LHC Prototype Magnet String, paper presented at the CEC 97 conference, Portland, 1997
7. Hepak, by CRYODATA Inc., P.O. Box 558, Niwot, Colorado 80544, USA
8. Benoit Hilbert, Modeling and experimental analysis of the thermohydraulics of resistive transitions on the LHC prototype magnet string, LHC Project Note 86, CERN/LHC 1997
9. L. Brue, Modélisation Thermohydraulique des Ecoulements Transitoires d'Hélium Cryogénique induits dans la Ligne de Récupération du Demi-Octant par les Transitions Résistives des Aimants du LHC, LHC Note 262, CERN AT/94-03 (CR)
10. M.Chorowski, Transient behaviour and helium recovery in the LHC cryogenic system following magnet resistive transitions, LHC Project note 77, CERN/LHC, 1997