

68

SLAC-Pub-7475
January 1997



KEKB and PEP-II B Factories

John. T. Seeman

Stanford Linear Accelerator Center*
Stanford University, Stanford, CA 94309, USA

SW 0732

Two asymmetric B-Factories KEBK at KEK and PEP-II at SLAC are under construction, designed to study CP violation in the b-quark sector with a center of mass energy of 10.58 GeV. These two new accelerators are high luminosity two-ring two-energy $e^+ e^-$ colliders with one interaction point. There are many challenging accelerator physics and engineering issues associated with the high beam currents and high luminosities of these rings. The chosen solutions to these issues and the general parameters of the two rings are described in detail side-by-side below. KEBK and PEP-II are well into the installation phase and are both scheduled to be completed in 1998. The particle physics programs are scheduled to start in 1999.

1A. KEBK B-FACTORY OVERVIEW

KEKB [1-7] is a two ring asymmetric electron-positron collider at 3.5 x 8 GeV being built in the TRISTAN tunnel at the Japan National Laboratory for High Energy Physics KEK in Tsukuba. The five year KEBK construction project was approved by the Japanese government in April 1994. The overall layout of KEBK is shown in Figure 1A and its parameters are listed in Section 2A. The two beams will collide in the Tsukuba experimental hall where the BELLE detector will be located. The salient features of KEBK are side-by-side rings, +/- 11 mrad crossing angles at the collision point with non-radiating straight incoming beams, new RF cavities: copper cavities with high stored energy (ARES) and superconducting cavities both designed to reduce the strength of the bunch-by-bunch feedback systems, many bunches (5000), high stored beam currents (2.6 A x 1.1 A), superconducting IR quadrupoles, novel 2.5π lattice design for flexibility, and an upgraded linac for full energy injection of both beams with new transport lines. Successful high current beam tests of many important hardware components of KEBK were made in the TRISTAN Accumulator Ring in 1996.

1B. PEP-II B-FACTORY OVERVIEW

PEP-II [1-7] is a two ring asymmetric electron-positron collider at 3.1 x 9.0 GeV being built in the PEP tunnel at the Stanford Linear Accelerator Center SLAC. The five year PEP-II construction project was approved by the Department of Energy of the United States Government in January 1994. A collaboration of SLAC, Lawrence Berkeley National Laboratory LBNL, and Lawrence Livermore National Laboratory LLNL is designing and constructing PEP-II. The overall layout of PEP-II is shown in Figure 1B and its parameters are listed in Section 2B. The beams will collide in the IR2 hall of the PEP tunnel where the BABAR detector will be located. The salient features of PEP-II are LER-above-the-HER rings, head-on collisions but with dipoles bends near the collision point, new copper RF cavities, strong bunch-by-bunch feedback systems, many bunches (1658), high stored charges (2.1 A x 1.0 A), permanent IR quadrupoles and dipoles, and use of the existing SLAC linac as an injector but with new transport lines. High current beam tests of the transverse and longitudinal feedbacks and studies of the fast ion instability have been successfully completed at the ALS at LBNL.

* Work supported by the US Department of Energy under contract DE-AC03-76SF00515.

Invited presentation at the 4th KEK Topical Conference on 'Flavor Physics',
Tsukuba, Ibaraki-ken, 305, Japan, October 29-31, 1996.

2A. KEKB ACCELERATOR PARAMETERS

Parameter	LER	HER
Beam energy (GeV)	3.5	8.0
CM energy (GeV)	10.58	
Particle type	e+	e-
Circumference (m)	3016.3	
Bending radius (m)	16.3	104.5
Length of bend magnet (m)	0.915	5.86
Crossing angle (mrad)	+/- 11.0	
Luminosity	$10^{34} \text{ cm}^{-2}\text{sec}^{-1}$	
Beam-beam tune shift (y)	0.052	
Beam-beam tune shift (x)	0.039	
β_y^*/β_x^* (cm/cm)	1./33.	1./33.
Optimum coupling (%)	2.0	2.0
Emittance (nm-rad) (y/x)	0.36/18.	0.36/18.
IP rms beam σ_y/σ_x (μm)	1.9/77.	1.9/77.
Dipole bends entering IP	None	None
Number of bunches	5000	5000
Particles per bunch	3.3×10^{10}	1.4×10^{10}
Bunch spacing (m)	0.59	0.59
Bunch length (mm)	4.0	4.0
Damping times (ms) (x/z)	43/23**	23
$\Delta E/\text{turn}$ (MeV)	0.81/1.5**	3.5
Radiation power (MW)	2.1/4.0**	3.8
HOM power (MW)	0.57	0.14
Total beam power (MW)	2.7/4.5**	4.0
Current per bunch (mA)	0.52	0.22
Total current (A)	2.6	1.1
RF frequency (MHz)	508.9	508.9
Harmonic number	5120	5120
Ion clearing gap (buckets)	---	120
RF voltage (MV)	4.9 - 9.4	8.7 - 16.2
Number ARES RF cavities ⁺	20-22	0-->36
Number SC RF cavities ⁺	0	12-->0
Number crab cavities	2	2
Crab voltage/cavity (MV)	1.41	1.44
Rel. energy spread (10^{-3})	0.71	0.67
Synchrotron tune	0.01-0.02	
Betatron tune (ν_x/ν_y)	45.52/45.08	47.52/43.08
Mom. compaction factor	$1-2 \times 10^{-4}$	$1-2 \times 10^{-4}$
Linac injection rate (Hz)	50	50
Full injection time (min) ⁺⁺	13-14	3

** (without wiggler/with wiggler)
⁺HER RF cavity numbers depends on future choices.
⁺⁺100% injection efficiency with one beam injection

2B. PEP-II ACCELERATOR PARAMETERS

Parameter	LER	HER
Beam energy (GeV)	3.1	9.0
CM energy (GeV)	10.58	
Particle type	e+	e-
Circumference (m)	2199.318	
Bending radius (m)	13.75	165.
Length of bend magnet (m)	0.45	5.4
Crossing angle (mrad)	0.0	
Luminosity	$3 \times 10^{33} \text{ cm}^{-2}\text{sec}^{-1}$	
Beam-beam tune shift (y)	0.03	
Beam-beam tune shift (x)	0.03	
β_y^*/β_x^* (cm/cm)	1.5/50.	2./67.
Optimum coupling (%)	3.0	3.0
Emittance (nm-rad) (y/x)	2.0/66.	1.5/49.
IP rms beam σ_y/σ_x (μm)	5.4/181.	5.4/181.
Dipole bends entering IP	Yes	Yes
Number of bunches	1658	1658
Particles per bunch	6.0×10^{10}	2.8×10^{10}
Bunch spacing (m)	1.26	1.26
Bunch length (mm)	10.0	11.0
Damping times (ms) (x/z)	62.5/30**	37./18.3
$\Delta E/\text{turn}$ (MeV)	0.75**	3.6
Radiation power (MW)	1.62**	3.58
HOM power (MW)	0.23	0.15
Total beam power (MW)	1.85**	3.73
Current per bunch (mA)	1.30	0.60
Total current (A)	2.16	1.0
RF frequency (MHz)	476.	476.
Harmonic number	3492	3492
Ion clearing gap (buckets)	---	176
RF voltage (MV)	5.1	14.0
Gap voltage/cavity (MV)	0.85	0.7
Number klystrons	3	5
Number RF cavities	6	20
Number crab cavities	0	0
Rel. energy spread (10^{-3})	0.77	0.61
Synchrotron tune	0.0334	0.0449
Betatron tune (ν_x/ν_y)	38.57/36.64	24.62/23.64
Mom. compaction factor	1.23×10^{-3}	2.4×10^{-3}
Linac injection rate (Hz)	60	120
Full injection time (min) ⁺⁺	3	2

** (with wiggler)
⁺⁺100% injection efficiency with one beam injection

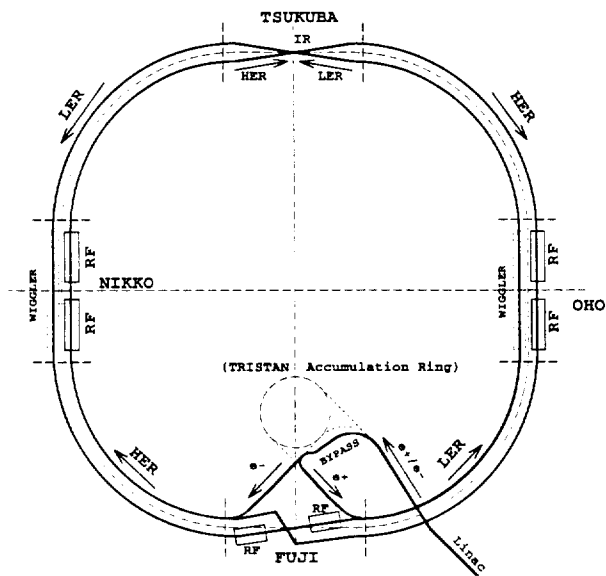

Figure 1A KEKB B-Factory Overview

3A. KEKB LATTICE DESIGN

The magnetic lattice for KEKB is a noninterleaved 2.5π phase advance cell with local chromaticity correction near the interaction point. Both the Low Energy Ring (LER) and the High Energy Ring (HER) have the same general lattice. These lattices are designed to provide (1) short damping times (23-46 msec), (2) large dynamic aperture ($>1.2 \times 10^{-5}$ m with $\pm 0.5\%$ momentum spread), (3) good lifetimes (>10 hr) including Touschek lifetime in the LER, (4) a wide range of tunability of beam parameters especially the horizontal emittance ($1-3.6 \times 10^{-8}$ m), and (5) reasonable tolerances to machine errors. For chromaticity corrections in the arcs a noninterleaved sextupole scheme is used. The vertical correction sextupoles in the interaction region are connected together to make a "pseudo -I" transformer to correct the large chromaticity due to the low betatron functions at the collision point. Studies of the beam-beam interaction with these lattices and with the crossing angles have shown sufficient dynamic aperture in KEKB and have determined the choice of operating betatron tunes.

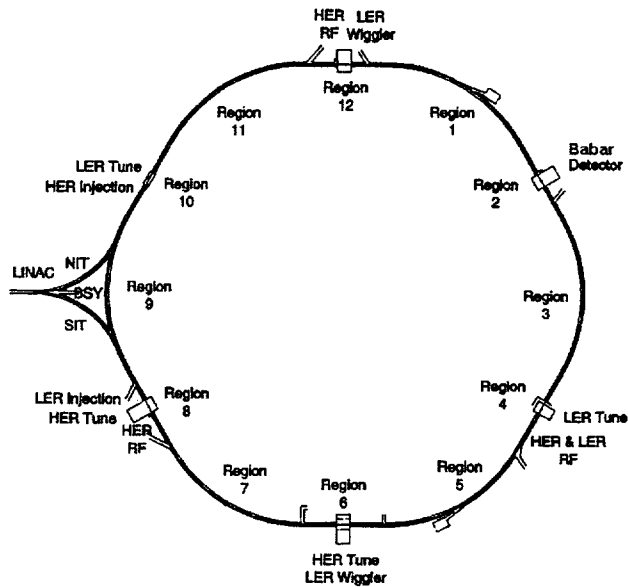

Figure 1B PEP-II B Factory Overview

3B. PEP-II LATTICE DESIGN

The PEP-II magnetic lattices for the High Energy Ring (HER) and the Low Energy Ring (LER) are significantly different. The HER has a 60 degree per cell lattice in the arcs with standard interleaved sextupole chromaticity correction. The chromaticity correction in the HER interaction region is made using "beta-beats" (high single plane betas at the sextupoles) in the nearby arcs with pairs of x and y sextupoles π phase advance apart. The LER has a 90 degrees per cell lattice in the arcs with a noninterleaved sextupole correction scheme. In the LER interaction region the chromaticity correction is semi-local with the y correction done in the IR and the x correction made in the nearby arcs. These lattices provide for horizontal emittance ranges of 20-80 nm in the LER and 40-70 nm in the HER. The beam lifetimes are expected to be acceptable because the dynamic apertures are about $14 \sigma_{x,y}$ with 10σ energy offset for the HER and $10\sigma_{x,y}$ with 10σ energy offset in the LER. Lattices with β_{y^*} down to 1.0 cm have been successfully simulated with errors for both rings. Beam-beam interaction studies have been used to select the betatron tunes.

4A. KEKB RF SYSTEM

The LER will use ARES room temperature cavities as shown in Figure 2A. The ARES system has a HOM-damped accelerating cavity coupled to a high-Q energy storage cavity (TE013) via a coupling cavity. There are two HOM absorber arrangements for ARES and both have satisfactory performance. The HER will use a combination of ARES and superconducting (SC) cavities as shown in Figure 2B. The SC cavities are single cells with room temperature beam line ferrite HOM absorbers. The required klystrons and high voltage power supplies will be reused from TRISTAN. Both of cavities types were tested successfully at 570 mA in AR tests in Fall 1996.

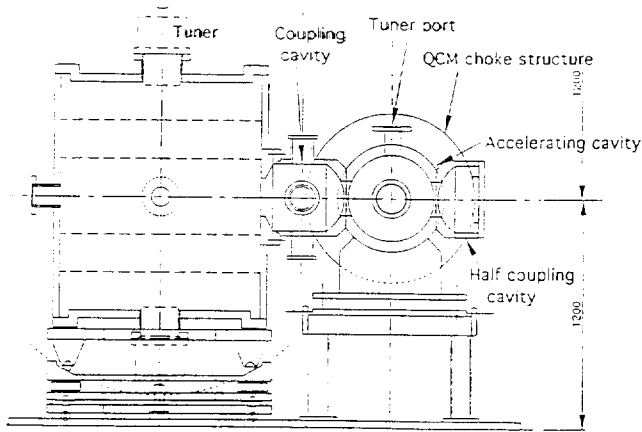

Figure 2A. KEKB ARES RF cavity

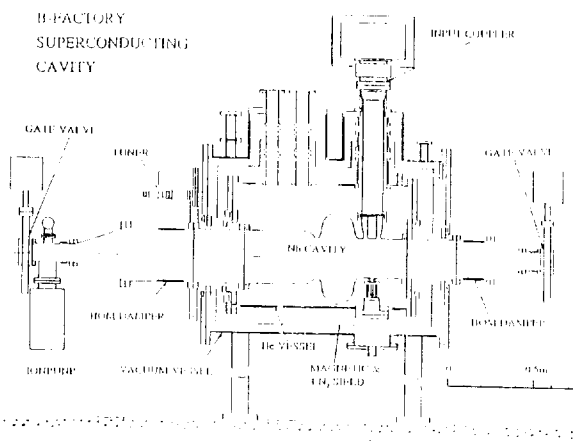

Figure 2B. KEKB superconducting cavity

4B. PEP-II RF SYSTEM

The RF systems for all rings must supply sufficient voltage for good beam lifetimes, handle heavy beam loading, and have a low impedance to reduce multi-bunch beam instabilities. PEP-II will use single cell copper cavities with three HOM absorber. The HER will have four cavities per klystron and the LER two. Figure 2C shows a PEP-II RF cavity. Due to high heating of the copper, special cooling channels with plated copper outer walls have been developed. The cavities are E-beam welded with staged machining and tuning steps. The 1.2 MW klystrons are being made in industry and the high voltage power supplies have SCR controller diode stacks and crowbar diode stacks using a new design from SLAC. The HOM absorbers of AlN+40%SiC tiles have had successful tests. The high power RF windows are ceramic with a stainless steel compression ring and are coated with TiN. The tuner is a copper plunger with Glidcop fingers silver and rhodium coated. Complete cavity systems have been tested to full power and tuners cycled with power for the equivalent of two years of operation. The low level RF control system includes feedback loops, comb filters, fast interlocks, network analysis, beam aborts, phase control, high voltage and drive control, and EPICs overall control. Eight cavities have installed in the HER for April 1998 initial commissioning.

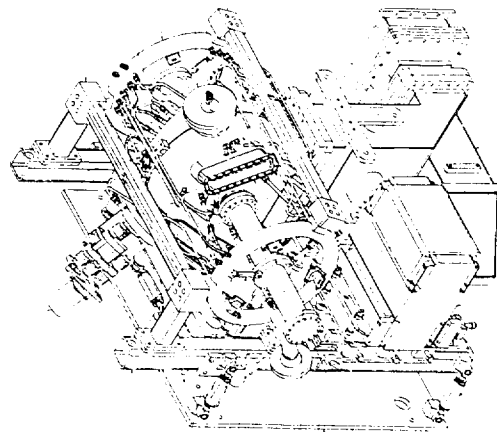

Figure 2C. PEP-II copper RF Cavity

5A. KEKB VACUUM SYSTEM

The vacuum chambers for both rings of KEKB will be made from extruded copper, E-beam welded and use Helicoflex seals as gaskets and RF contacts. The HER chambers are shown in Figures 3A and 7A. The HER chambers are racetrack shaped and have distributed NEG pumping with sputter ion pumps every ten meters. The LER chambers shown in Figures 4A and 8A are round to reduce the resistive wall instability. Pumping in the LER is from NEG cartridges placed at meter spacings, ion pumps every 10 m, and a roughing port every 40 m. The pumping ports use grids to reduce beam impedance effects. The design of the vacuum bellows module has liner fingers with external force clamps. This design uses robust RF contacts which have been tested to high power, which is sufficient for the 20 W of expected HOM leakage, 10W of Joule heating, and 10 W of scattered synchrotron power. There are small masks upstream of these bellows modules to shadow direct synchrotron radiation. Several of these bellows have been successfully tested in the AR test in fall 1996. The vacuum chambers with BPMs will be supported at the quadrupole but will be independently supported elsewhere.

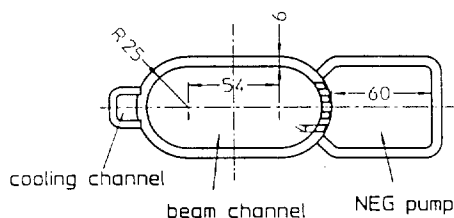

Figure 3A. KEKB HER Cu vacuum chamber

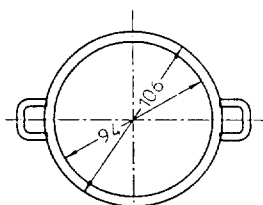

Figure 4A. KEKB LER Cu vacuum chamber

5B. PEP-II VACUUM SYSTEM

In PEP-II the HER arc vacuum chambers will be extruded copper, the LER arc chambers will be aluminum with antechambers, and the straight section have water cooled cylindrical stainless steel pipes. The HER arc chambers are shown in Figures 3B and 7B and the LER arc chambers in Figures 4B and 8B. The HER vacuum chambers are made to absorb over 100 W/cm of synchrotron radiation and pumped using distributed ion pumps. The synchrotron radiation in the LER is absorbed in Glidcop (grooved) photon stops located in the pumping chamber antechamber. The large TSP pumps below the photon stops allow the gas pressure near the beam to be improved, equalizing the two beam lifetimes. There are special copper chambers near the wigglers in LER and high pumping speed chambers in the IR region to reduce the pressure to the nanoTorr level. The HER and straight sections will use Conflat seals and the LER arcs and most diagnostics Helicoflex seals. The delicate bellows modules will use Glidcop fingers with either external compression fingers or a keeper ring (straights) for constant force. The vacuum chambers with BPMs will be supported from the quadrupole magnets.

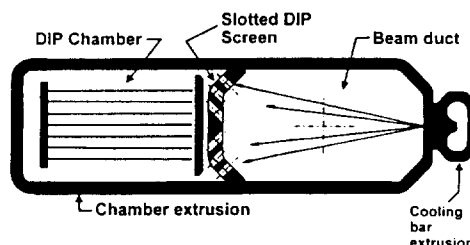

Figure 3B. PEP-II HER Cu dipole chamber

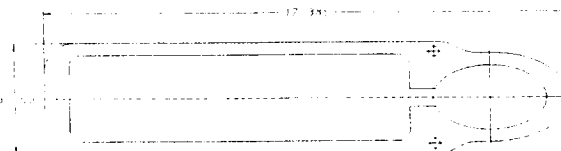

Figure 4B. PEP-II LER Al pumping chamber

6A. KEKB INTERACTION REGION

In KEKB the LER and HER beams are brought together horizontally, collided, and returned over a distance of about 200 m. The layout is shown in Figure 5A. The two beams are collided with ± 11 mrad crossing angles without dipole bending for the incoming beam. The particle physics detector BELLE will have a solenoid with a 1.5 T field. The vacuum pressure near the detector will be at the 1 nTorr level to make acceptable backgrounds. Local dipole bending of the LER (positron) beam is to provide dispersion where sextupoles correct the local vertical chromaticity. The crossing angle allows beam in every RF bucket.

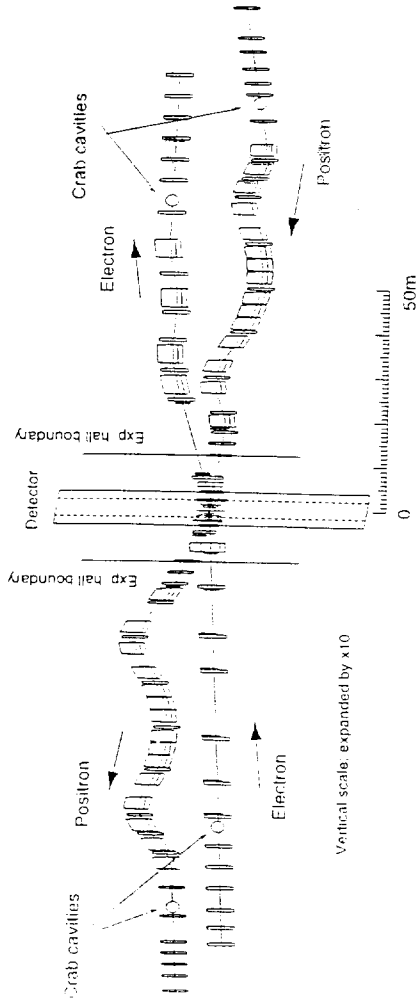

Figure 5A. KEKB Interaction Region Layout (plan view)

6B. PEP-II INTERACTION REGION

In PEP-II the LER and HER beams are brought together first vertically then horizontally, collided, and returned over a distance of about 120 m. The layout is shown in Figure 5B. The two beams collide head-on requiring strong dipole fields near the interaction point. The particle physics detector BABAR will have a solenoid with a 1.5 T field. The local vacuum pressure will be about 0.7 nTorr for the HER and about 1.4 nTorr for the LER to make acceptable backgrounds. Local dipole bending of the LER (positron) beam is to provide dispersion where sextupoles correct the local vertical chromaticity. Head-on collisions allow bunches at most in every other bucket.

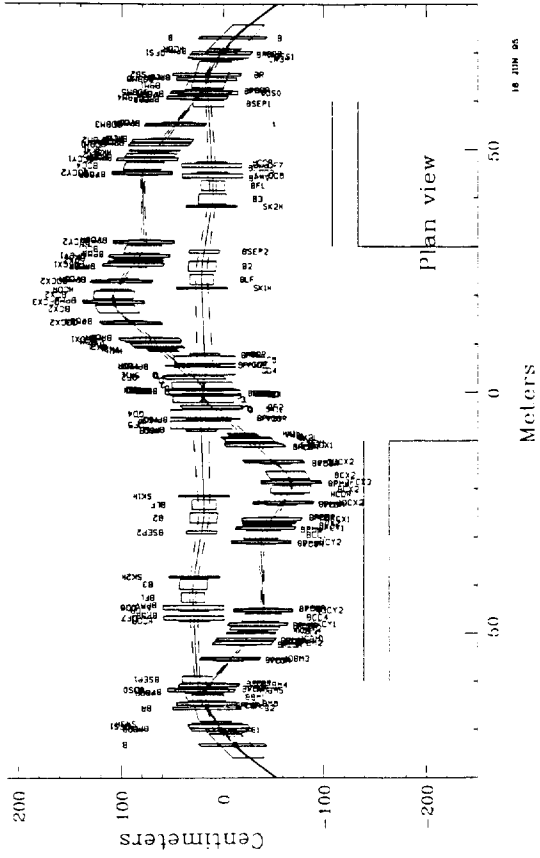

Figure 5B. PEP-II Interaction Region Layout (plan view)

7A. KEKB IR ISSUES

The layout of the collision point in KEKB is shown in Figure 6A. The first quadrupole QCS is superconducting also housing skew quadrupole and x-y dipole windings. Farther away, several special iron septum quadrupoles are needed in both rings to complete the IP doublet optics and to allow the two beams to separate. The separation "crotch" vacuum chambers are designed to absorb synchrotron radiation power and include position monitors for each beam. The BELLE detector is self-shielding requiring movable concrete radiation shielding for nearby IR components.

The compensation of the detector solenoid is done by a pair of reverse solenoids near the collision point with small trim skew quadrupoles in the interaction region. The BELLE field will be mapped with the reverse solenoids and SC quadrupoles installed.

The 20 mm radius Be IP beam pipe and nearby bellows are supported from the BELLE detector with a "magic" vacuum flange connection nearby. The expected higher order mode heating of the Be pipe is about 200 W. The total radiation dose to the Silicon Vertex Chamber is calculated to be about 6 kRad/yr.

To correct the small beam-beam effects of tilted bunches arising from the crossing angles, a "crab" RF cavity system is being developed to be ready shortly after commissioning starts. The transverse cavity kicks on both sides of the IR of order 1.4 MV are needed to straighten the bunches at the collision point.

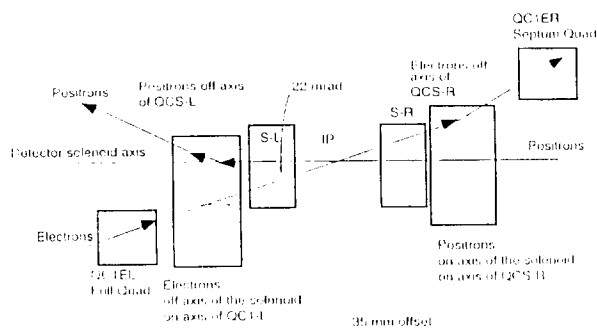

Figure 6A. KEKB collision point layout

7B. PEP-II IR ISSUES

The layout of the collision point in PEP-II is shown in Figure 6B. Near the collision point the first dipole B1 and first quadrupole Q1 are permanent magnets with 10^{-4} field tolerances and off-axis beams. The next several magnets are special iron septum quadrupoles needed in the IR to complete the doublet focusing and to allow the two beams to separate.

The compensation of the BABAR solenoid is done with six strong skew quadrupoles on each side of the interaction region per ring. Significant vertical and horizontal steering corrections are also needed for compensation. Four other skew quadrupoles around the ring correct global coupling in each ring. Mapping of the BABAR field will be done with the nearby iron quadrupoles in place.

The water cooled 25 mm radius Be IP beam pipe is supported along with the IR B1 dipoles and Q1 quadrupoles in a carbon fiber support tube cantilevered from the nearby machine support rafts. The expected higher order mode heating of the Be beam pipe is about 250 W with 1000 W as a worst case. There are high Z photon masks to absorb several kilowatts of synchrotron radiation striking nearby. High power "crotch" vacuum chambers are made of Glidcop. Movable horizontal W collimators will be installed upstream of the collision point in each ring to reduce lost particle backgrounds in BABAR. The total radiation dose to the Silicon Vertex Tracker is expected at about 40 kRad/yr.

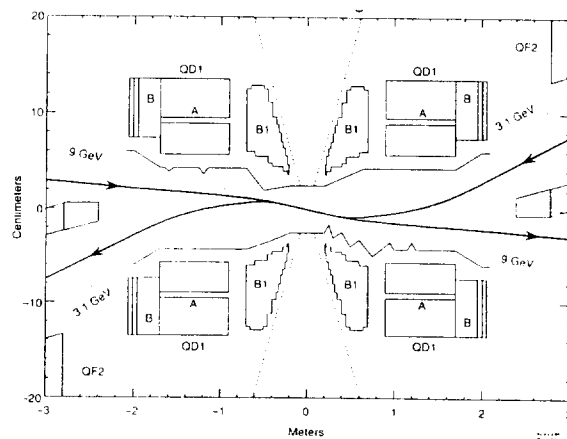

Figure 6B. PEP-II collision point layout

8A. KEKB BEAM DIAGNOSTICS

KEKB has 452 beam position monitors (BPM) in both the HER and LER. The BPMs are button pickups with 12 mm diameters. The peak resolution is better than 10 microns. The front end electronics is a superheterodyne system working at 1 GHz. The processing time is about 250 msec per button. Signals down to 0.1 mA bunch charge are measurable. The coaxial feedthrough of the button is specially shaped to reduce the narrow band beam impedance. The BPMs for the HER and LER are shown in Figures 7A and 8A.

The beam sizes will be measured using synchrotron radiation from a specially constructed low field dipole. The Be extraction mirror will be mounted on a Cu block. Wave front correction mirrors will be employed to correct thermal mirror distortions. Diffraction limited optics will provide images of 507/680 μm for LER/HER horizontally including about 10% increase from diffraction and 102/158 μm LER/HER vertically including about a 35 % diffraction enhancement.

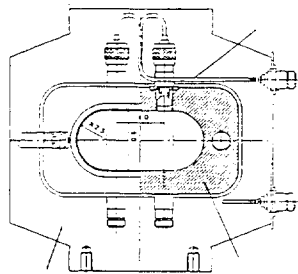

Figure 7A. KEKB HER position monitor

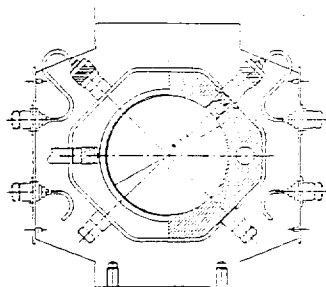

Figure 8A. KEKB LER position monitor

8B. PEP-II BEAM DIAGNOSTICS

PEP-II has about 300 position monitors in the HER and 340 in the LER. The BPMs are button monitors with diameters of 15 mm. The size was chosen to make the beam impedance acceptable. The BPM electronics can read positions on a single bunch passage with resolutions better than 20 μm on a single turn and less than 1 μm averaged. The BPM processor operates at 952 MHz and can record 1024 consecutive turns for analysis. The PEP-II BPMs are shown in Figures 7B and 8B.

The beam sizes in PEP-II will be measured using synchrotron radiation (300 nm) from normal arc bending magnets in the two rings. The light will be extracted using a nickel-plated polished Glidcop water-cooled grazing-incidence mirror with a 8 mm slot to pass most of the high power. This mirror in the HER is located in the wall of the dipole chamber and in the LER downstream of a specially made slot in a photon stop. The expected beam sizes are about 700/800 μm horizontally and 190/218 μm vertically [HER/LER] including a few percent increase from diffraction.

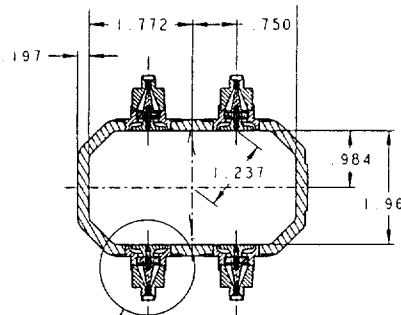

Figure 7B. PEP-II HER arc position monitor

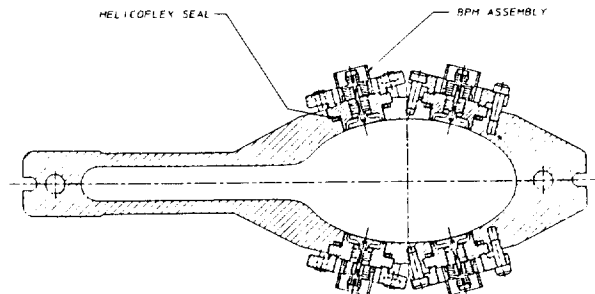

Figure 8B. PEP-II LER arc position monitor

9A. KEKB INJECTION

The existing KEKB linac is being upgraded to inject at full energy into KEKB. The upgrade overview is shown in Figure 9A. The upgrade involves more linac accelerating sections, newly designed SLED energy doublers, higher power klystrons, improved diagnostics, new positron target, and a new high current gun. The energy will be increased from 2.5 GeV to 8 GeV for e- and to 3.5 GeV for e+. The positron production per pulse will be increased from 0.032 nC to 0.64 nC. New transport lines from the linac to KEKB are under construction including an energy collimation system. A damping ring for reduced positron emittance is being considered. Ring top-off ($\Delta I=12\%$) is expected about every hour.

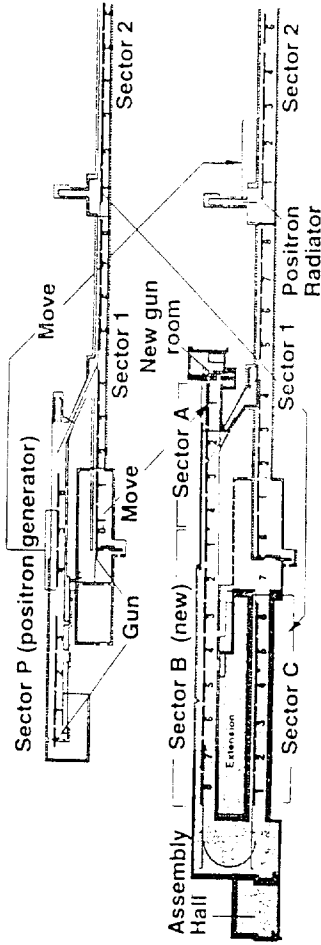

Figure 9A. Overview of the Linac and Transport Upgrade for KEKB.

9B. PEP-II INJECTION

The existing 50 GeV SLAC linac as modified for the SLC with damping rings will be used for PEP-II injection. See Figure 9B. The two beams are extracted at their respective energies in the linac tunnel and transported to PEP-II in "bypass" lines. The positron line has an energy range of 2.5 to 4 GeV and the electron line 7 to 12 GeV. The linac operates at 120 Hz. An electron bunch can be injected on every linac pulse, a positron pulse every other pulse, or interleaved at 40 Hz each. Intensities per pulse can range from a few 10^8 to 4×10^{10} with invariant emittances of about 5×10^{-5} rad-m. Top-off of each beam ($\Delta I=20\%$) is expected about every hour while keeping the ring bunch charges equal to about 2%.

Injector Schematic

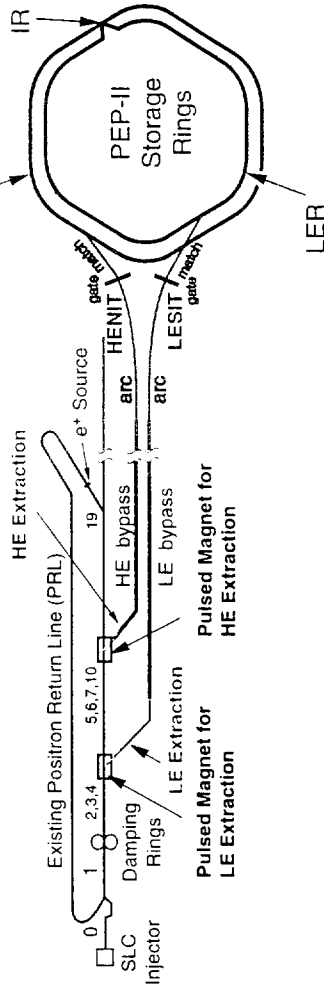

Figure 9B. Overview of the Linac Injection System for PEP-II

10A. KEKB MILESTONES

<u>Date</u>	<u>Milestone or Commissioning</u>
1994 April	Start of Construction
1995 December	Start removing TRISTAN
1995 July	Bids out for LER construction
1996 May	Bids out for HER construction
1996 July-Nov.	Beam tests in Accum. Ring
1996 December	Start bypass tunnel constr.
1997 February	Start magnet installation
1997 October	Complete new bypass tunnel
1998 May-June	Commission full upgraded linac and transport lines
1998 October	Commission full KEKB Accelerator (HER and LER)
1999 Early	Start particle physics program (BELLE)

ACKNOWLEDGMENTS

Many thanks are extended to Profs. S. Kurokawa, Y. Ogawa, and the staff of KEKB and the KEK Linac for providing interesting discussions about their accelerators.

KEKB REFERENCES

1. "KEKB B-Factory Design Report", KEK Report 95-7, (1995).
2. "Design Report on PF Injector Linac Upgrade for KEKB", KEK Report 95-18, (1996).
3. T. Kageyama et al, "ARES cavity for the KEKB-Factory", Proceedings of EPAC96, 2008 (1996).
4. T. Furuya et al., "Prototype Module of a Superconducting Damped Cavity for KEKB", Proceedings of EPAC96, 2121 (1996).
5. S. Kurokawa, "KEKB Status and Plans", Proceedings of USPAC95, 491 (1995).
6. K. Kanazawa and Y. Suetsugu, "Development of a Bellows Assembly with RF shield for KEKB", Proceedings of USPAC95, 1072 (1995).
7. S. Kurokawa et al, "KEKB Accelerator Review," KEKB Accelerator Review Committee Meeting, unpublished report, January 23-25 (1997).

10B. PEP-II MILESTONES

<u>Date</u>	<u>Milestone or Commissioning</u>
1994 January	Start of Construction
1994 July	Tunnel cleared
1995 October	Electron injection transport studies
1997 April	HER injection studies
1997 May	HER stored beam
1997 June	Positron injection transport studies
1997 September	LER injection (part turn)
1998 April	LER stored beam
1998 May	Start IR commissioning
1998 June	Start to collide beams
1999 April	Start particle physics program (BABAR)

ACKNOWLEDGMENTS

Many thanks are extended to Prof. J. Dorfan and the PEP-II staff for providing interesting discussions, information, and support during the design and construction of PEP-II.

PEP-II REFERENCES

1. J. Dorfan, M. Zisman, et al, "PEP-II Conceptual Design Report", SLAC Report 418, LBL-PUB-5379, June (1993).
2. T. Fieguth et al., "PEP-II Injection Transport Construction and Commissioning Plans", Proceedings of USPAC95, 1876 (1995).
3. R. Rimmer, et al, "High-Power Testing of the First PEP-II RF Cavity", Proceedings of EPAC96, 2032 (1996).
4. P. Corredoura et al., "Low-level RF System for the PEP-II B-Factory", Proceedings of USPAC95, 2672 (1995).
5. E. Hoyt et al., "Copper Beam Chamber for PEP-II", Proceedings USPAC95, 2054, (1996).
6. D. Hunt et al, "Design of the LER Vacuum System", Proceeding USPAC95, 2067 (1995).
7. J. Seeman et al., "PEP-II Accelerator Review", PEP-II Machine Advisory Committee Meeting, unpublished report, January 6-8 (1997).