

EE

LBNL-39879
UC-410

**ERNEST ORLANDO LAWRENCE
BERKELEY NATIONAL LABORATORY**

**Mechanical Design of a
Pinger System for the
LBNL Advanced Light
Source Accelerator**

W. Thur, J. Akre, A. Gavidia,
and J. Guigli
**Accelerator and Fusion
Research Division**

May 1997
Presented at the
*Particle Accelerator
Conference*,
Vancouver, B.C., Canada,
May 12-16, 1997,
and to be published in
the Proceedings

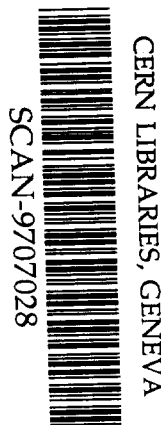

swg727

DISCLAIMER

This document was prepared as an account of work sponsored by the United States Government. While this document is believed to contain correct information, neither the United States Government nor any agency thereof, nor The Regents of the University of California, nor any of their employees, makes any warranty, express or implied, or assumes any legal responsibility for the accuracy, completeness, or usefulness of any information, apparatus, product, or process disclosed, or represents that its use would not infringe privately owned rights. Reference herein to any specific commercial product, process, or service by its trade name, trademark, manufacturer, or otherwise, does not necessarily constitute or imply its endorsement, recommendation, or favoring by the United States Government or any agency thereof, or The Regents of the University of California. The views and opinions of authors expressed herein do not necessarily state or reflect those of the United States Government or any agency thereof, or The Regents of the University of California.

Ernest Orlando Lawrence Berkeley National Laboratory
is an equal opportunity employer.

LBL-39879
UC-410

**Mechanical Design of a Pinger System
for the LBNL Advanced Light Source Accelerator**

W. Thur, J. Akre, A. Gavidia, and J. Guigli

Advanced Light Source
Accelerator and Fusion Research Division
Ernest Orlando Lawrence Berkeley National Laboratory
University of California
Berkeley, California 94720

May 1997

This work was supported by the Director, Office of Energy Research, Office of Basic Energy Sciences, Materials Sciences Division, of the U.S. Department of Energy under Contract No. DE-AC03-76SF00098.

MECHANICAL DESIGN OF A PINGER SYSTEM FOR THE LBNL ADVANCED LIGHT SOURCE ACCELERATOR

W. Thur, J. Akre, A. Gavidia and J. Guigli, Lawrence Berkeley National Laboratory

Abstract

A fast magnet "Pinger System" has been designed for the Advanced Light Source 1.9 GEV electron Storage Ring. Intended for beam dynamics studies, its purpose is to provide a fast (< 600 ns) transverse magnetic field pulse to perturb the orbit of an electron bunch in a single turn. A key component is the special resistive-coated ceramic beam tube which is needed for fast magnetic field penetration. The evolution of the design concept is described, with emphasis on simplifications to provide an economical and mechanically robust device.

1 INTRODUCTION

The Advanced Light Source at Lawrence Berkeley National Laboratory is a third generation synchrotron radiation source. The ALS storage ring circulates bunched electrons at energies of 1.0 to 1.9 GeV, at currents up to 400 mA. Bend magnets, undulators, and wigglers produce intense photon beams with energies from 10 eV to 10 keV for a wide variety of experiments.

As more photon beamlines are added to the ALS, tuning the storage ring for precise electron beam position and stability at all beamlines becomes increasingly difficult. To meet this challenge, ALS accelerator physicists are working to improve their understanding of the complex electron beam dynamics of the storage ring. The new "Pinger System" is currently being installed, and will be an important tool in this effort.

2 THE PINGER SYSTEM - SPECIFICATIONS

The new Pinger system will provide a pair of very fast dipole magnets to intentionally perturb the orbit of a single electron bunch in a single pass. The effects of this controlled transverse "kick" will be monitored by an existing system of beam position monitors for validation and improvement of beam dynamics models. In order to accomplish this, the Pinger system must deliver calibrated vertical and/or horizontal dipole fields of up to 315 Gauss in a pulse which lasts no longer than 650 nanoseconds. This will require single turn dipole magnets, discharging 10 kilovolts to ground. A special ceramic beam tube section is needed so that induced eddy currents will not retard the penetration of the magnetic field.

3 ENGINEERING

As is often the case, the initial intention for this project was to closely duplicate an existing design. The beam kickers in the ALS injection straight perform a similar function, and we hoped to save on engineering costs. However, a closer study of the injection straight revealed many reasons not to do this. The following is a brief summary of the design evolution of the Pinger system.

As you will see, considerable effort has gone into creating a cost effective, reliable design, with many well-motivated departures from the original concept.

3.1 Reference Designs

Our reference design, the ALS injection straight, has a rectangular vacuum aperture of 83 x 38 mm. Its ceramic vacuum tube was expensive, difficult to manufacture, difficult to align, and the unbalanced vacuum forces stressing the ceramic are high. For the Pinger, an 88 mm ID round ceramic beam tube was chosen to be much stronger, easier to fabricate, and its "square" aperture allows the horizontal and vertical kick magnets to be essentially identical. A further advantage emerged: in the round geometry, beam image currents can be handled by a uniform resistive coating on the tube ID, with no need for the difficult patterned resistive coating used with the rectangular aperture. The optimum coating resistance is a trade-off between minimizing the eddy current induced field penetration delay, and living with the steady state I^2R heating of the ceramic tube caused by beam image currents of up to 400 mA. An experimental mock-up indicates that a 2.0 ohm per square coating of titanium will allow acceptable field penetration times with a maximum steady state image current heat load of about 100 watts, which will be cooled with an air flow system.

3.2 RF Concerns

The original electrical joint design used to connect the injection straight resistive coating to the conventional metal beam tube has caused some concern at the ALS. Beam current induced heating at or very near these joints has necessitated forced air cooling. Although the cause of this problem has not been resolved, a leading theory is that small cavities in the electrical joint design may be coupling with RF energy, resulting in local heating. In the Pinger design, only a single, round fingerstock joint is used, with a minimum cavity.

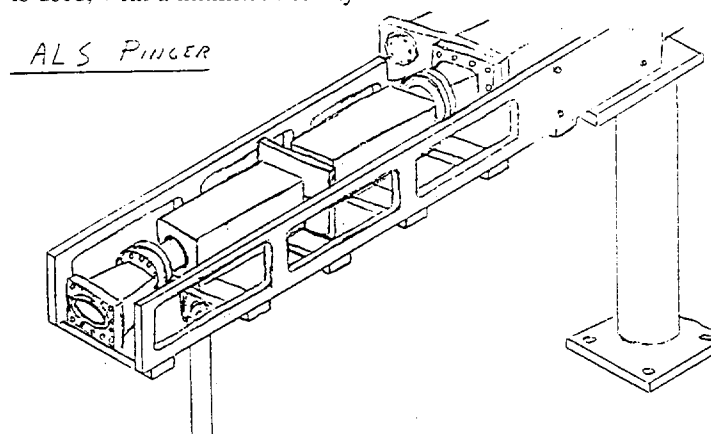

Figure 1 - An early concept sketch for the ALS Pinger

3.3 Simplifications

The various risks and expense of the ceramic tube end electrical and vacuum connections motivated a further simplification: - a single long ceramic tube threaded through both the horizontal and the vertical kick magnets. A 54 inch tube length is required, with only two end connections, rather than the four which would have been needed with separate tubes for each magnet.

3.4 Support and Vacuum Loads

The support and alignment of the ceramic tubes in the injection straight had also been a problem, due to variations in ceramic wall thickness. For the Pinger, we will avoid this by not doing it! We plan to rely only on the engagement of the electrical contact sleeve in the neighboring transition piece to flexibly support the 25 lb. weight of the ceramic tube.

Axial vacuum loads were considerable in the injection straight design because of the difference in cross section between the large round bellows and the "racetrack" ceramic tube aperture it encloses. (The collapsing load of the bellows exerts a sizable tension load on the ceramic tube.) Since the Pinger ceramic tube is round, it is possible to use a bellows of only slightly larger area than the tube itself. The calculated vacuum load tension in the Pinger ceramic tube is much reduced; - only 102 lbs. This load is taken in tension by the Kovar fittings brazed to the ends of the ceramic beam tube. The maximum stress in the critical braze joint was further reduced by making the O.D. of the ceramic backing ring 1.8 mm larger than the ceramic tube. A finite element analysis shows that this small change will reduce the maximum stress in the braze joint by a factor of six. These increased safety margins all work to improve the vacuum integrity of the ALS storage ring.

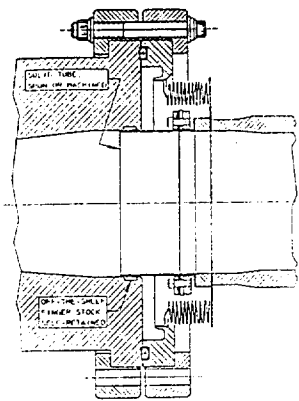

Figure 2 - Ceramic Tube End Joint Design

3.5 System Layout

The Pinger system will be installed in ALS straight section 2. The one-piece ceramic tube allows the Pinger to be short enough to occupy only the upstream half of the straight section, reserving the downstream half for future diagnostic instruments, or possibly even an insertion device. In this location, photon masking had to be carefully considered; that is, the synchrotron radiation

from the bend magnet immediately upstream had to be absorbed by a water cooled photon stop incorporated in the Pinger transition piece. In the course of studying these layouts, a further simplification emerged: There is no need for the electron beam to be perfectly centered in the ceramic beam tube. By introducing an intentional offset of 10 mm, we were able to reduce the tube inner diameter from 88 mm to only 74 mm. This resulted in a reduced magnet aperture and a reduced pulsed power requirement to drive the magnets.

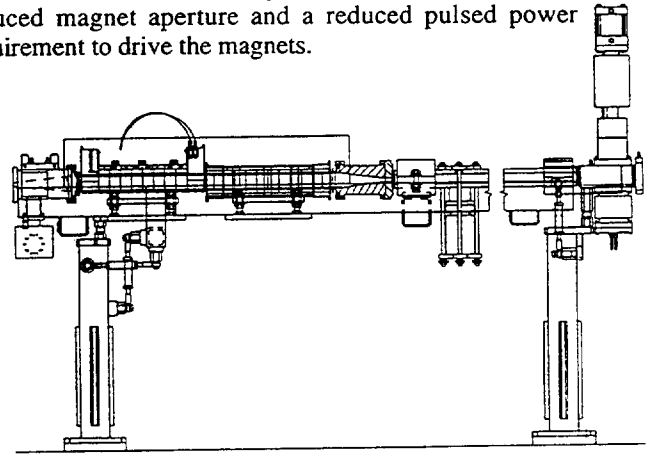

Figure 3 - The ALS Pinger system

4 FABRICATION AND INSTALLATION

With a robust, conservative design in hand, we confronted the realities of component procurement. The ceramic tube with its brazed Kovar metal end fittings turned out to be an exceedingly involved fabrication. Over 20 different ceramic, metalization, and brazing vendors were contacted, revealing a wide variety of capabilities and limitations. Ultimately, the 1.35 meter long 99.5% alumina tubes were pressed, fired, and metalized in 0.68 meter long halves by WesGo, Inc. of Belmont, Ca., and these were subsequently brazed together and to their Kovar metal end fittings by Alpha Braze of Fremont, Ca.

Other design involvements include the "transition pieces" which are EDM'd (Electric Discharge Machined) from solid metal blocks to provide a smooth vacuum chamber transition from the elliptical section of the storage ring to the round ceramic tube, and a carefully thought out support system designed to protect the ceramic beam tube from mechanical stress, especially in torsion. As this is written in May 1997, we are in the midst of the May 1997 shutdown of the ALS, and the vacuum related components of the Pinger system are being installed, with the fast magnets to follow at a later date.

Like many accelerator upgrade projects, an idea which initially sounded fairly straightforward has spawned a rich mix of engineering complications and challenges. If we succeed in delivering a working ALS Pinger system sometime this summer, it will be cause for a celebration!

REFERENCES

- [1] D.E. Anderson, G. Stover and W. Thur, Design of Quasi-Traveling Wave Pinger Magnet for Beam Diagnostics on the Advanced Light Source, Particle Accelerator Conference, 1997