

sw9713

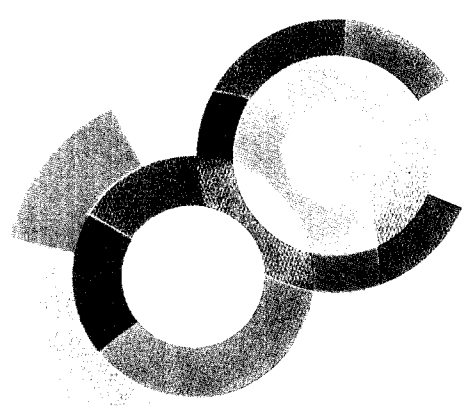
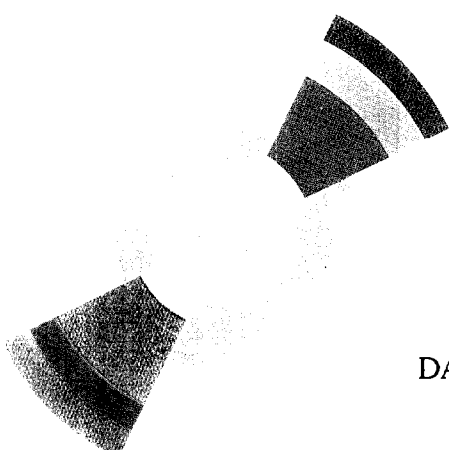

DAPNIA/SIG 97-01

January 1997

DEVELOPMENT OF AN OPTICAL SENSOR FOR 2D
MULTI-POINT ALIGNMENT

J.Ch. Barrière, H. Blumenfeld, M. Bourdinaud,
O. Cloué, F. Molinié, Ph. Schune

Submitted to Nuclear Instruments and Methods A

DAPNIA

Le DAPNIA (Département d'Astrophysique, de physique des Particules, de physique Nucléaire et de l'Instrumentation Associée) regroupe les activités du Service d'Astrophysique (SAp), du Département de Physique des Particules Élémentaires (DPhPE) et du Département de Physique Nucléaire (DPhN).

Adresse : DAPNIA, Bâtiment 141
 CEA Saclay
 F - 91191 Gif-sur-Yvette Cedex

Development of an optical sensor for 2D multi-point alignment

J.-Ch. Barrière, H. Blumenfeld, M. Bourdinaud ;
O. Cloué, F. Molinié, Ph. Schune †
CEA-Saclay, DSM/DAPNIA
F-91191 Gif sur Yvette Cédex, France.

ABSTRACT

A new type of highly transparent (95%) 2D position sensor has been developed which allows the accurate positioning ($5 \mu\text{m}$ r.m.s.) of successive elements to which each sensor is attached, transversally to a laser beam used as a reference straight line. The usefull area of the sensor is about $15 \times 15 \text{ mm}^2$.

1 Introduction

An optical sensor (SATRAPs*) has been developed at Saclay. It will be used as an optical element in a track simulator over a distance of 6 meters (using several SATRAPs) for the global alignment test benchmark of the ATLAS [1] muon chambers.

The useful area needed for this application is typically $10 \times 10 \text{ mm}^2$ for a global resolution of the order or below $20 \mu\text{m}$.

2 Principle

A SATRAPs is made of Neodymium (1%) doped glass plates, 40 mm wide and 3 mm thick. The plate faces are optically polished with a precision of $0.5 \mu\text{m}$ ($\lambda/2$) over a $30 \times 30 \text{ mm}^2$ area. Fluorescent light (at about 1060 nm) produced by a laser beam crossing the plate is detected using 16 silicon photodiode pixels ($3 \times 10.52 \text{ mm}^2$ each) glued all around the plate (4 pixels on each side). See Fig. 1.

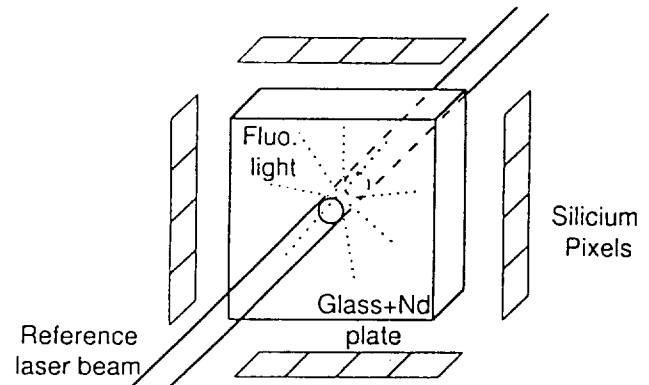

Figure 1: Principle of the SATRAPs. The glue is not shown.

Pixel currents are amplified ($\times 3.10^6$) and converted into voltage, then filtered and finally digitized (with a 16 bits precision over 10 V). Typical voltages of 1 to 5 volts are measured with a 12 mW laser power, depending on the pixel position with respect to the beam impact position.

The laser is a diode laser working at 685 nm. At this wavelength, the optical sensor is highly transparent (95%) allowing alignment of multiple elements.

An algorithm has been developed (see the Results section) to reconstruct the laser spot

*e-mail : bourdinaud at hep.saclay.cea.fr

†e-mail : schune at hep.saclay.cea.fr

*SAclay TRANSPARENT Position Sensor

position. It uses the measurements of the currents obtained on the pixels interpolated with a calibration grid.

3 Experimental set-up

In order to evaluate the SATRAPs laser spot positioning precision, we have used the following set-up. A fixed diode laser beam is focused (the laser spot diameter is about $300 \mu\text{m}$) on a movable SATRAPs 30 cm away. Displacements in a plane transverse to the beam are obtained with two micrometric tables ($1\mu\text{m}$ precision) perpendicular to each other ($\pm 25\mu\text{rad}$). There are two other SATRAPs in this set-up : one between the diode laser and the movable one and the third one 15 cm after it. They are used to correct for the beam pointing variation with time (see Fig. 2).

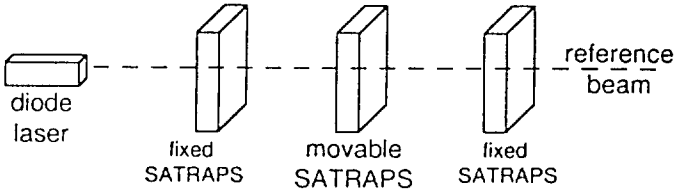

Figure 2: Experimental set-up with three SATRAPs, one movable, and two fixed (for laser pointing variation correction).

4 Results

To determine an unknown laser spot position (x_0^u, y_0^u) , characterized by its 16 pixels voltages $V_{i=1,16}^u$, a calibration is needed. It is obtained via a reference grid. This grid is built using the illumination of the SATRAPs (by the diode laser) for different known positions, thanks to the micrometric tables, at which we readout

and record the 16 pixels voltages ($V_{i=1,16}^{\text{ref}}$). The size of the grid is $25 \times 25 \text{ mm}^2$ with 1 by 1 mm steps.

The positions x (resp. y) are parametrized by a polynomial function with 16 parameters a_i (resp. b_i) :

$$x \text{ (resp. } y) = \sum_{i=1}^{16} a_i \text{ (resp. } b_i) V_i$$

Using all the reference grid positions with their associated V_i^{ref} , the 32 a_i and b_i parameters are determined from a χ^2 built according to the previous equation.

With these 32 parameters and replacing V_i^{ref} by V_i^u the unknown positions $x_{\text{Step } 1}^u$ and $y_{\text{Step } 1}^u$ are computed.

At this level, the difference between $(x_{\text{Step } 1}^u, y_{\text{Step } 1}^u)$ and the true position (x_0^u, y_0^u) (known from the micrometric table positions) is normally distributed with a $50 \mu\text{m}$ precision (r.m.s.). A 2D B-Spline [2] algorithm performed on the reference grid is used to determine hypothetical points $(x_{\text{hyp}}^{\text{ref}}, y_{\text{hyp}}^{\text{ref}})$, close to the $(x_{\text{Step } 1}^u, y_{\text{Step } 1}^u)$ region, associated with hypothetical voltages ($V_{i=1,16}^{\text{ref hyp}}$).

By performing the same type of polynomial fit with these hypothetical points 16 new parameters for x , $a_{i \text{ hyp}}$ (and also 16 for y ; $b_{i \text{ hyp}}$), are obtained.

As for the first step, these determine a final reconstructed position $(x_{\text{final}}^u = \sum_i a_{i \text{ hyp}} V_i^{\text{ref hyp}})$ but this time with a resolution of few microns (below $10 \mu\text{m}$ r.m.s.).

The two other fixed SATRAPs allow to correct for laser beam pointing instability (after a calibration grid has been performed for each of them), reducing the final resolution to $5 \mu\text{m}$ r.m.s. .

5 Perspectives

We are now testing the sensitivity of the resolution to the laser spot size difference, between the reference grid points and the unknown points, on the SATRAPs. Indeed a large spot size may induce different fluorescent light distribution on the pixels contrary to a small spot size thus increasing the final resolution. Monte-Carlo studies have been performed in order to understand this effect. It should not increase the resolution by more than 7 to 10 microns. This still to be verified in real life.

6 Conclusions

We have developed a new type of highly transparent 2D position sensor. For a stable spot size, from a diode laser beam, the resolution on a useful area of about $15 \times 15 \text{ mm}^2$ is $5 \mu\text{m}$ r.m.s. with only 16 pixels readout. The size of the SATRAPs (and thus the useful area) could be increased with a constant pixel number keeping the resolution at this level.

Acknowledgements

We would like to thank for fruitful discussions C. Guyot, J.F. Laporte and J.P. Schuller.

References

- [1] ATLAS, Technical Proposal, CERN/LHCC/94-43, 15 December 1994.
- [2] NAG Fortran Library Program, NAG Ltd, Oxford, United Kingdom.