

ОБЪЕДИНЕННЫЙ
ИНСТИТУТ
ЯДЕРНЫХ
ИССЛЕДОВАНИЙ

Дубна

EE

E9-96-343

A.M.Baldin, A.D.Kovalenko, N.N.Agapov,
H.G.Khodzhibagiyan, E.A.Matyushevsky, A.A.Smirnov,
I.A.Shelaev

HOW A 100 TeV SYNCHROTRON/COLLIDER BASED
ON THE NUCLOTRON-TYPE CRYOMAGNETIC
SYSTEM WOULD LOOK

Submitted to the Fifth European Particle Accelerator Conference,
June 10—14 1996, Barcelona, Spain

SCAN-9702035



CERN LIBRARIES, GENEVA

SW0707

1 INTRODUCTION

The idea to consider how a 100 TeV range accelerator based on the Nuclotron-type cryomagnetic system would look was stimulated by the news from Fermilab about studying of the new low-cost approaches to superhigh energy hadron colliders. At present time the most attention is attracted to the LHC construction at CERN. This machine is based on superconducting cos-theta type high field dipoles ($B = 8.65$ T) and quadrupoles to be operated at $T=1.8$ K. It will provide the $E_{c.m.}$ energy of 14 TeV for pp-collisions. The LHC remain the World Biggest Accelerator after the SSC project was terminated in 1994. But $E_{c.m.} = 14$ TeV is not a limiting energy motivated by high energy physics researches. There are many fundamental problems, for example search for the violation of the sum of baryonic and leptonic numbers in the Standard Model, multiple Higgs-particle production, etc which can be investigated only at an energy range substantially above the LHC limit.

The first our estimates of beam energy and luminosity as well as the basic parameters of the accelerator were presented at Mini-Symposium organized by E.Malamud and G.W.Foster in the frames of APS Annual Meeting to be held in May 2-5, 1996 in Indianapolis [1]. (see also: <http://waldo.fnal.gov/pipe/>)

Naturally, the feasibility of a multi-TeV accelerators of the next generation will depend on its cost, both as capital and operational.

Our point of view is that the only miniature iron-shaped low-field ($B=2-2.5$ T) magnets with superconducting coils can provide needed minimization of accelerator cost (about 10 times less per TeV than LHC).

As was mentioned by G.W.Foster: "Tevatron→Hera →SSC→LHC represents an evolutionary dead end for superconducting magnet technology. Cos-theta type high-field magnets will never be 10 times less cheaper. The LHC-like dipoles would never work at 100 TeV".

2 NUCLOTRON

2.1 General status

The Laboratory of High Energies (LHE) JINR was a pioneer in designing and constructing the first low-cost accelerator named Nuclotron which is based on low-field iron dominated magnets. Nuclotron was built during five years (1987-1992), the main equipment of magnetic and many other systems of it were fabricated by JINR and LHE workshops without recourse to industry. The Nuclotron ring of 251 m in perimeter is installed in a technological tunnel with a cross-section of $2.5 \times 3 \text{ m}^2$ (Fig.1). The total "cold mass" of the magnetic system is about 80 ton. Nine runs of a total duration of 2200 hours were carried out from March 1993. The

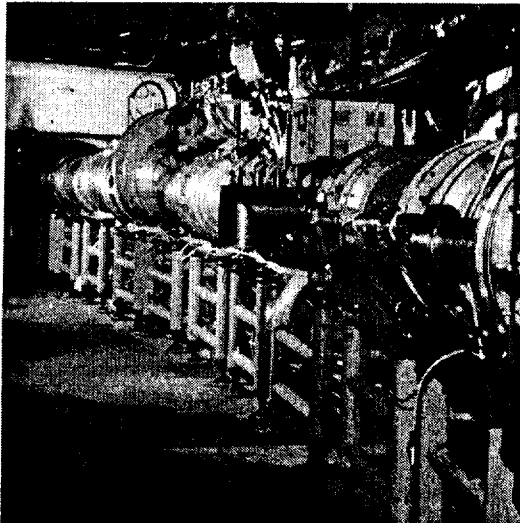

Figure 1. The Nuclotron ring in the tunnel

investigation of the cryomagnetic and other accelerator systems as well as data taken for physics experiments were performed. Different operation modes, in particular, variation of the magnet supply current over a

range of 0.1-3 kA, rise time - (0.6-1.8) kA/sec, flat top of current pulse - (0.1-10) sec were tested. The minimal cooldown time of the ring was 78 hours.

2.2 Preconstruction

The first conceptual design proposal of the Nuclotron was formulated early in the 70th. Pulsed SC-dipoles with a peak magnetic field of 6 T were suggested to be used for the main ring. However, after the first tests of cos Θ -type high-field SC-magnets had been performed, further R&D works were reoriented at investigation of an iron shaped field SC-magnets.

Five different modifications of 2-2,5 T pulsed superconducting dipoles were constructed and tested at LHE up to 1978. A "window-frame" type magnet provides in the case minimization of both the SC-coils cross-section, the iron yoke weight and stored energy. High homogeneity of the magnetic field across the aperture is also achieved. The model superconducting system - 1.5 GeV Synchrotrons - SPIN based on such magnets had been fabricated and tested at LHE before the Nuclotron construction was began. The SPIN-type magnets named "superferric" in western publications were later also investigated at other Laboratories. A new version of the miniature iron-shaped field SC-magnet at LHE was constructed by 1978. The SC-winding in this case was made of a specially designed tube-type superconductor cable to be manufactured of a 5 mm in diameter cupro-nickel tube with a wall thickness of 0.5 mm and 31 connected in parallel multifilament SC-wires of 0,5 mm in diameter covering an outer surface of the tube. Two-phase helium passing through the tube provides circulatory cooling the coil down to 4.5 K while for the SPIN-type magnets immersible cooling was used. Due to lower average current density the SC-coils cross section of the tube-type magnets are larger and as a result its weight and stored energy are higher in compare to the SPIN-type ones. Nevertheless, the "tube-type" magnets had a crucial advantage - very simple and effective cooling system which makes it possible to

achieve a fast cycling mode of operation (up to 1 Hz). After successful tests of the "tube-type" magnets the final version of the Nuclotron was formulated [2].

2.3 Cryomagnetic system

The first results of the Nuclotron operation as well as more detailed description of its cryomagnetic system and parameters of the SC-magnets were presented earlier [3],[4],[5]. The Nuclotron ring comprises 96 dipole magnets 1.5 m long, 64 quadrupole lenses 0.45 m long, 28 multipole correctors and other equipment for beam injection, monitoring, acceleration and extraction. Even in the case of a rather large aperture $55 \times 110 \text{ mm}^2$ (Fig.2) normalized per unit of length weight of the Nuclotron magnetic system – about 300 kg/m – is the smallest among circular accelerators. Other advantages such as minimal amount of helium inside the cryostat, safety, good mechanical stability, minimization of any connections are also provided with the Nuclotron-type magnetic system. The magnetic ele-

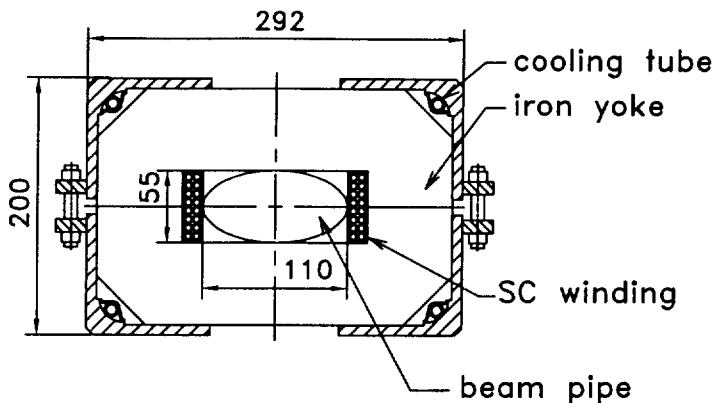

Figure 2. Cross-section of the Nuclotron dipole

ments are connected in parallel with input and output helium headers.

The ring is divided into two cryostats of 125 m long supplied by helium refrigerator of a nominal capacity of 1.6 kW at 4.5 K each. The main heat load is connected determined by dynamic heat releases due to fast cycling mode of the Nuclotron operation. The mass vapour content of the helium varies from 0 at the inlet of the magnet to 0.9 at its outlet. Helium in the supply header of each half-ring is kept in a liquid state by means of a phase separator, a main subcooler and a number of small subcoolers. During all nine runs of operation the cooling of the magnets was stable. No flow oscillations in the parallel cooling channels and no quenches in magnetic elements were observed under the pressure difference above 15 kPa between the supply and return headers.

3 A 100 TeV NUCLOTRON

The results of extrapolation of the Nuclotron-type cryomagnetic system for 1000 km ring are listed in Table 1. The unit of cryomagnetic system is schematically shown in Fig.3. Cryogenic structure of the unit is similar to the Nuclotron one. The magnets are connected to helium headers in parallel. But only direct cooling of iron yoke is assumed. The iron yoke cross-section is a window-frame type with two rectangular apertures of 30×20 mm² each. The SC-winding is a single turn, made of plane NbTi superconductor cable. Taking into account the gap height (20 mm) drive current of 34 kA is enough to produce magnetic field of 2 T. The length of the magnet is correspond to the total length of tube type superconductor cable which the Nuclotron dipole coils are made of. There is substantial difference of the helium headers cross-sections compare to the Nuclotron ones in the case of a long transfer lines.

We have no doubt that all parameters of a 100 TeV range accelerator based on the Nuclotron-type cryomagnetic system looks very realistic. Of course, we didn't consider magnetic structure of the ring. Anyway, if is

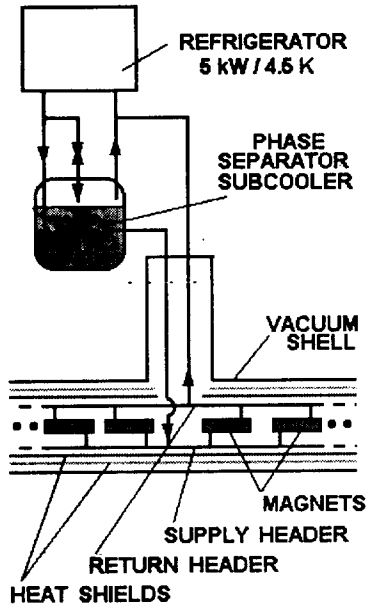

Figure 3. A possible unit of 2×5 km long of cryomagnetic system for a multi-TeV range accelerator

clear that 2-in-1 window-frame magnets with plane single turn SC-winding are universal to construct both as dipole and quadrupole magnets. Notice, that it is easy to provide different direction of the magnetic field across the gaps.

Very interesting concept of superferric magnet for big accelerator was proposed by G.W.Foster. This is "double-C twin bore transmission line magnet". The proposal of a 32×32 TeV hadron collider at Fermilab base on such magnets was presented by him at above mentioned meeting in Indianapolis.

Table 1. Estimated parameters of 1000 km Accelerator

Circumference	1000	km
Total cold mass	60	kton
Vacuum vessel outer diameter	0.28	m
Total refrigerator capacity	500	kW
Cooldown time	140	hrs
Ring segmentation:		
number of cryogenic units	100	
unit capacity at 4.5 K	5	kW
number of strings in unit	2	
number of magnet in string	100	
helium headers cross-section (supply/return)	55/108	cm ²
Magnet:		
window frame Nuclotron type		2-in-1
peak field	2.2	T
length	50	m
aperture (horizontal/vertical)	30/20	mm
stored energy	~3	kJ/m
yoke sizes (horizontal/vertical)	130/55	mm
inductance (per beam)	~3	$\mu\text{H}/\text{m}$
winding		single turn
weight of NbTi	2×10	kg
drive current	34	kA
coolant: two-phase helium		
operating temperature	4.7-4.4	K

4 CONCLUSION

We consider a low-cost low field iron dominated superconducting miniature magnets as the only feasible concept for superhigh energy hadron accelerators of the next generation.

References

- [1] Baldin A.M., Kovalenko A.D. "A 100 TeV Synchrotron/Collider based on the Nuclotron-type Cryomagnetic System". APS Annual Meeting, Indianapolis, May 2-5, (1996), also JINR Rapid Comm. v. 3 /77/-96 Dubna, 1996 (to be published).
- [2] Baldin A.M. et al. IEEE Trans. Nucl. Sci., v. NS-30, N 4, p. 3247, (1983).
- [3] Kovalenko A.D. Status of the Nuclotron. Proceedings EPAC-94, London (1995), v. 1, p. 161-164.
- [4] Baldin A.M. et al. Cryogenic System of the Nuclotron-a new Superconducting Synchrotron, Adv. Cryogen. Eng. v. 39, p. 501-508, (1994).
- [5] Baldin A.M. et al, Superconducting Fast Cycling Magnets of the Nuclotron, IEEE Trans. on Appl. Superconductivity, v. 5, N 2, p. 875-877 (1995).

Received by Publishing Department
on September 23, 1996.

Балдин А.М. и др.

E9-96-343

Как выглядел бы синхротрон/коллайдер на энергию 100 ТэВ,
основанный на криогенно-магнитной системе типа нуклотрон

Представлены данные экстраполяции параметров криогенно-магнитной системы типа нуклотрон для синхротрона/коллайдера на энергию масштаба 100 ТэВ. Данные основаны на опыте работы нуклотрона и результатах разработки миниатюрных сверхпроводящих магнитов с полем, формируемым ферромагнитными сердечниками. Обсуждены возможные направления дальнейшей оптимизации крупно-масштабных криомагнитных систем для адронных ускорителей и коллайдеров следующего поколения.

Работа выполнена в Лаборатории высоких энергий ОИЯИ.

Препринт Объединенного института ядерных исследований. Дубна, 1996

Baldin A.M. et al.

E9-96-343

How a 100 TeV Synchrotron/Collider

Based on the Nuclotron-Type Cryomagnetic System Would Look

The extrapolation of the Nuclotron-type cryomagnetic system parameters for a 100 TeV range synchrotron/collider is considered. The presented data are based on Nuclotron operational experience and R&D works on miniature iron-shaped low-field SC-magnets carried out at the Laboratory of High Energies. Possible ways for further optimization of very large scale cryomagnetic system for hadron accelerators and colliders of the next generation are discussed.

The investigation has been performed at the Laboratory of High Energies, JINR.

Preprint of the Joint Institute for Nuclear Research. Dubna, 1996

Макет Т.Е.Попеко

Подписано в печать 01.10.96
Формат 60 × 90/16. Офсетная печать. Уч.-изд. листов 0,99
Тираж 305. Заказ 49408. Цена 1188 р.

Издательский отдел Объединенного института ядерных исследований
Дубна Московской области