

# SUPERCONDUCTING COIL COMPRESSION BY SCISSOR LAMINATIONS

Albert Ijspeert, Jukka Salminen, CERN, Geneva, Switzerland

## ABSTRACT

A new system of coil compression [1] has been designed which uses iron laminations to transfer the pressure from an outer shrink ring to the coil. The laminations are simple circular discs around the coil with the peculiarity that the rim is slightly eccentric as compared to the coil. Successive laminations are mounted with different angular orientations to oppose their eccentricities. The shrink ring pushes these discs inwards against the coil creating compression by a scissor movement. Tests on mechanical models of single as well as multiple aperture magnets have shown it to work as expected. The system has already successfully been applied to several corrector magnets for LHC. The advantages are low cost (suppression of the usual collars), increased coil compression in particular from cooling down, and field enhancement from having the iron close to the coil.

## 1 INTRODUCTION

Coils of superconducting magnets for accelerators need to be compressed to avoid wire movements which would cause quenches. The prestress is in general obtained by collaring the coils under a press or by shrinking rings around the coils. The iron yoke can help increase the pre-compression if pushed inwards by an outer shell but at the expense of subdividing the yoke into different segments. Scissor laminations offer a simple and economic alternative to regular collar systems.

## 2 PRINCIPLE

The principle of the scissor laminations is shown in figure 1. The yoke is made of a single type of ring-shaped laminations stacked around the magnet coil. They have the peculiarity that the circular periphery is designed to be slightly off-centre as compared to the magnet centre ( $\sim 0.5$  mm). These laminations are mounted with different angular orientations. The outer shrinking shell presses on the wider side of each lamination only and the latter transmits the compressive force to the coil. The wide side of each lamination simply acts as a local spacer between the shrink ring and the coil and the rest of the circular lamination is free. In general the laminations are oriented per pair of opposing eccentricity each pair compressing the coil thanks to the “scissor” effect. Cooling the magnet to cryogenic temperatures enhances the pre-compression of the coil if the shrink ring is of a strongly shrinking

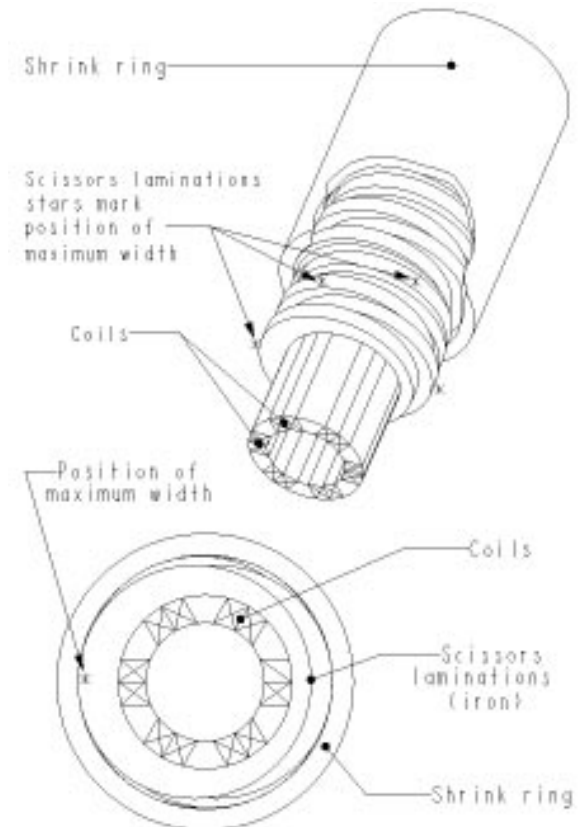

Figure: 1 Principle of Scissor laminations. Shown is sextupole corrector.(eccentricity strongly exaggerated)

material such as aluminium or stainless steel. If desired, one can introduce keys in the laminations to stop the scissor action beyond a certain cooling temperature. Another way to stop it is to choose such an eccentricity that the peripheries of the laminations line up at a well defined cooling temperature. This can be used to build up a circular compression on the laminations that stiffens the yoke; the Lorentz forces that would tend to move the laminations outwards must first overcome that pre-compression before any elastic movement can occur. The scissor system is readily applicable to magnets with more than one aperture, as shown in sections 4, 5.

## 3 SINGLE APERTURE APPLICATIONS

The method has first been applied to some small superconducting corrector magnets for LHC. Originally their design consisted of a coil shrunk inside an aluminium shrink ring and this assembly was centred inside an iron yoke by means of keys [2]. This has now been simplified by packing the coil inside scissor laminations and shrinking the ring around this assembly.

The advantages are that the iron has been brought close to the coil boosting the field, that the shrink ring acts now at a larger diameter and is therefore easier to shrink and also yields more prestress when cooling down, and finally that it suppresses the expensive machining of keyways. Three different corrector magnet prototypes have been built along these lines, one sextupole and one decapole by INDAR, Spain and another sextupole by CERN [3]. Table 1 gives their data. All three magnets use the same enamelled wire of 0.61x1.13 mm metal cross section. The first magnets are made with vacuum

Table:1 Parameters of the three corrector prototypes

		INDAR sextupole	INDAR decapole	CERN sextupole
Magnet length	mm	150	75	150
Nominal current	A	383	346	625
Critical current (4.2K)	A	765	945	993
Peak field at crit. current	T	5.2	4.1	3.26
Coil Inner Diameter	mm	56	56	56
Coil Outer Diameter	mm	76	71	61
Number of radial layers		8	6	2
Number of turns		112	48	26
Diameter over coil insulation	mm	85.5	78.9	66
Scissors lamination I.D.	mm	86.2	79	66.2
Scissors lamination O.D.	mm	115	95.2	89.4
Largest lamination width	mm	15.1	8.4	12
Smallest lamination width	mm	13.8	7.7	11.2
Lamination thickness	mm	0.8	0.8	1
Angular orientations		6	10	6
Aluminium shrink ring I.D.	mm	115.4	95.3	89.88
Shrink ring O.D.	mm	140	106	100
Interference on diameter	mm	0.35	0.44	0.12
Average coil prestress 300 K	MPa	-35	-46	-31
Expected coil prestress 4.2 K	MPa	-53	-47	-36

impregnated coils with several layers of winding. The last magnet is made in a more economical way with a two layer coil wetted with epoxy during the winding process. The coils of these magnets are protected with a 2.5 mm thick glassfiber epoxy layer and the laminations are directly placed around this insulation layer. The design did not incorporate a mechanical stop. The sextupole laminations were oriented in six angular positions. The circular coil assembly will therefore undergo a slightly hexagonal deformation calculated to be less than 0.03 mm on the radius which does not compromise the field quality. If necessary one can shape the opening in the laminations to compensate for this. This also implies that the coil is supported by local forces repeated every 4.8 or 6 mm over the length. The decapole laminations were oriented in ten angular positions and the pitch between every tenth lamination is 8 mm. The magnets have been trained at 4.2 K at CEDEX in Spain (Fig. 2). The first two magnets show one quench at or below the nominal current. The third magnet starts training well above the nominal current. Compared to other designs with similar impregnated coils the training is similar or even quicker which shows that the laminations give a successful pre-stress.

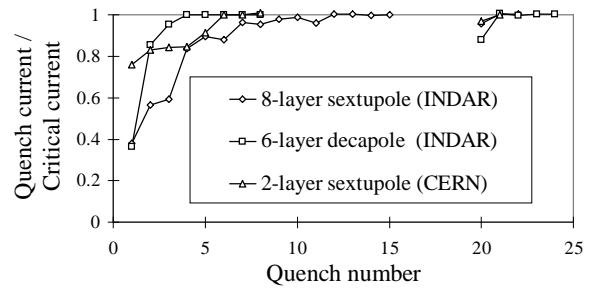

Fig: 2 Training and re-training of the three corrector prototypes

#### 4 MULTI APERTURE MODEL

The method can readily be applied to magnets with a multitude of apertures. A dummy assembly of a twin aperture model has been built and tested to measure the application to multi aperture magnets (Fig.3). In contrast to the single aperture case, one cannot turn the scissor lamination to any desired orientation. However, if the multiple apertures are symmetric in the X and the Y planes a single type of lamination can be used in four different positions: a starting position, an opposing position obtained by turning the plate over 180 degrees, and a third and fourth position by turning the first two plates upside-down. The angle of eccentricity can be chosen to 45 degrees as we did in this model for equal prestress in all four directions or it can be chosen differently to obtain a dominant pre-stress in one particular direction. The plate thickness was 5 mm and aluminium dummy coils were used as well as an aluminium shrink ring. The stresses as found from diameter measurements show (Fig.4) that the coil compression increases strongly during the cooldown and the alignment of the plates occurs at about 130 K. Beyond this temperature the shrinkage of the shrink ring is not acting on the coil anymore and the coil is slightly

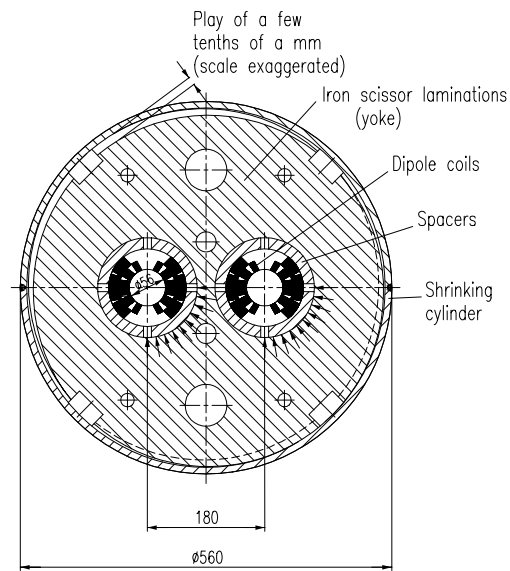

Fig:3 Mechanical model of twin aperture magnet

de-compressing. Several heat cycles showed that the results are repeatable. The pressure on the coil before and after a heat cycle are practically identical (+/- 10%) which means that frictional effects are very small. The model has several times successfully been disassembled and re-assembled, once using a real coil.

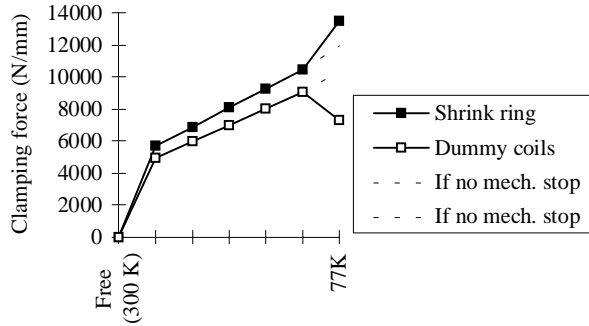

Fig:4 Clamping force in the twin aperture model (corresponding to coil stress of 40 MPa at 300K and 60 MPa at 77K for chosen interference)

## 5 TWIN APERTURE DESIGN

As a possible application to a multi aperture yoke a tentative design has been made for the LHC main dipole. Two questions turned up: Can one slip the laminations over the not yet collared coil which has dimensions a few millimetres larger than the compressed dimensions and how close can one bring the iron to the coil without losing the field homogeneity due to saturation of the iron at the very high field of 8.4 Tesla? To satisfy these demands we use the fact that each lamination only needs to touch the coil over the 90 degree angle where the pressure is exerted. The shape of the rest of the hole in the lamination can be at a larger radius to obtain the play necessary for the assembly. Magnetic calculations showed that the multipoles caused by local saturation in the iron can be reduced to less than  $10^{-4}$  of the main field over the whole range of excitation by shaping the hole of the iron lamination elliptical and by adding holes to the lamination in the correct positions (Fig.5). The calculations showed that the field homogeneity is not influenced by the iron quality at least less than in the present design. A cost estimation showed that the suppression of the usual collars may lead to an interesting cost saving on such a magnet. The assembly can be made by securing packages of laminations in the open position using keys, slip the packages over the coils, take the keys out, pre-compress the coils moderately under a press and maintain the compressed position introducing corresponding keys. The skin can then be welded around the magnet and the keyways are such that they accept the additional compression during cooldown loosening the keys.

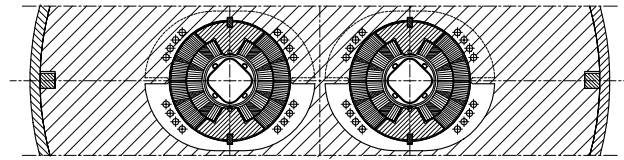

Fig:5 Elliptic lamination holes for field homogeneity

## 6 CONCLUSIONS

It has been shown that the scissor laminations form a practical and elegant way to transmit the compressive force from the shrink ring to the coil body. The yoke is built with a single type of lamination and does not need a subdivision in segments. The system allows to chose freely the desired direction of the prestress on the coil by orienting the laminations accordingly. It can replace the usual collars leading to non-negligible savings. It permits to bring the iron close to the coil enhancing the magnetic field and allowing to reduce the outer diameter of the yoke. Finally it allows to “collar” the coil at a relatively low compression because an additional compression can be obtained from the differential contractions during the cooldown thus avoiding damage to the insulation by over-stress at room temperature and reducing the size of the necessary press. The system has been tested on mechanical models and has already successfully been applied to several types of corrector magnets.

## 7 ACKNOWLEDGEMENTS

We would like to thank G. Laurent, H. Meyer and G. Trinquart for the design work, J. Mazet, J. Perez and D. Regin for the development work and the fabrication of the CERN prototype. Thanks go to J. Etxeandia and J. Garcia from INDAR Spain for the fabrication of the two other prototypes guided by E. Baynham, B. Coombs and D. Evans from DRAL England. Finally thanks go to L. Garcia Tabares, M. Bajko, J. Calero and M. Saenz de Buruaga of CEDEX Spain for the training tests at 4.2 K.

## REFERENCES

- [1] A. Ijspeert, ‘Compressing coils of single and multiple aperture superconducting magnets with “Scissors” laminations: principles and results of tests on mechanical models’, LHC Note 292, CERN, October 1994.
- [2] D. Baynham, R. Coombs, A. Ijspeert, R. Perin, ‘Design of superconducting corrector magnets for LHC’, IEEE Trans. on Magn., Vol.30, No 4, pp1823-1826, July 1994.
- [3] J. Salminen, A. Ijspeert, ‘Superconducting sextupole corrector magnet for the LHC main dipoles’, this conference.