

EE

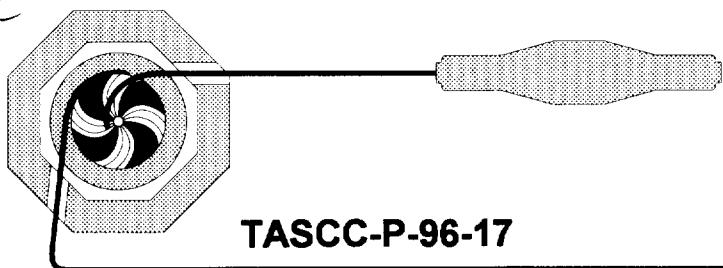

TASCC-P-96-17

PREPRINT

TASCC

***THE NEW CHALK RIVER AMS
ION SOURCE, SAMPLE CHANGER
AND EXTERNAL SAMPLE MAGAZINE***

V.T. Koslowsky, N. Bray, Y. Imahori, H.R. Andrews and W.G. Davies
AECL, Chalk River Laboratories, Chalk River, ON K0J 1J0, Canada

Presented at the 7th International Conference
on Accelerator Mass Spectrometry
Tucson Tucson, Arizona
1996 May 19-26

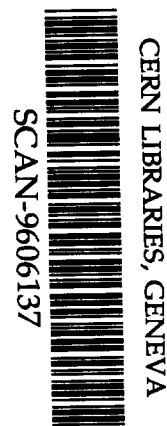

Swg626

NOTICE

This report is not a formal publication; if it is cited as a reference, the citation should indicate that the report is unpublished. To request copies our E-mail address is TASCC@CRL.AECL.CA.

Physical and Environmental Sciences
Chalk River Laboratories
Chalk River, ON K0J 1J0 Canada

1996 May



***The New Chalk River AMS Ion Source,
Sample Changer and External Sample Magazine***

V.T. Koslowsky^a, N. Bray, Y. Imahori, H.R. Andrews and W.G. Davies

AECL, Chalk River Laboratories
Chalk River, Ontario, Canada K0J 1J0

^a FAX: (613)-584-1800
Telephone: (613) 584-3311
e-mail: koslowsk@cu49.crl.aecl.ca

Abstract

A new sample magazine, sample changer and ion source have been developed and are in routine use at Chalk River. The system features a readily-accessible 40-sample magazine at ground potential that is external to the ion source and high-voltage cage. The samples are held in an inert atmosphere and can be individually examined or removed; they can be exchanged *en masse* as a complete magazine concurrent with an AMS measurement. On-line sample changing is done with a pneumatic rabbit transfer system employing two stages of differential pumping. At Chalk River this is routinely performed across a 200 kV potential. Sample positioning is precise, and hundreds of ³⁶Cl and ¹²⁹I samples have been measured over a period of several days without interruption or alteration of ion-source operating conditions.



1. INTRODUCTION

The Chalk River AMS program now uses a novel sample-changer and a new ion source that permits operation over extended periods of time without the need to alter or disturb ion-source potentials or to pause operation when exchanging samples. The sample-magazine is external to both the ion source and its high voltage deck. It operates at ground potential and at atmospheric pressure, thus permitting samples to be exchanged or examined with ease.

2. EXPERIMENTAL SETUP

2.1 Overview

Sample changes take place without altering any ion-source potential and involve three simple automatic motions: rotary positioning of the external magazine, pneumatic transfer of the sample onto the ion-source operating deck (200 kV at Chalk River) and a lateral slide into the ion source. There are no gate-valves or O-rings in this transfer system.

Up to 40 samples are mounted in a teflon wheel magazine that is located outside the ion-source high-voltage cage and at ground potential. Any sample (in its holder, see next section) can be aligned with the end of a plastic transfer tube, by stepping-motor control, and then blown through the tube onto the high voltage platform. There, the transferred sample lodges in a shaft that spans atmospheric pressure and ion-source vacuum regions. The shaft and the sample slides by pneumatic action through four self-lubricating, precision, linear bearings¹⁾ that provide two stages of differential pumping.

The linear motion places the sample precisely at the (cesium-ion) Cs focus of a negative-ion sputter source. Withdrawal of the sample is effected by reversing the insertion process. The duration between removal of a sample and the beginning of the next AMS sample measurement is about one minute, of which the sample exchange takes about 20 seconds.

The samples are held in an Ar atmosphere and are transferred with Ar gas. They can be individually examined or removed; they can be exchanged *en masse* as a complete magazine without interruption of AMS measurements. Since only one sample is in the source at any one time, direct sample-to-sample contamination is avoided.

2.2 The Sample Holder and Magazine

Sample holders are barrel-shaped slugs 6.2 mm in diameter and 9.5 mm long with a 1.5 mm diameter by 1.5 mm deep recess at one end that contains the compressed sample material (see Fig. 1). They are usually fabricated from OFHC copper. Up to 40 of these are placed face-up in wells in a horizontally-oriented Teflon magazine. The sample to be inserted is positioned by a stepping motor control to align it below the end of a 6.35 mm diameter nylon tube (see Fig. 2) that transverses the potential gap of the ion-source deck.

The magazine is hermetically sealed with a lucite cover and can be continuously flushed with an inert gas. Samples can be removed or inserted into the magazine at will or entire wheels exchanged.

2.3 Sample Transfer Between Magazine and Ion Source

The sample holders are blown with 3 atm of Ar gas through the 6.35 mm diameter transfer tube that connects the grounded magazine with the ion source. At Chalk River, a 15 m tube is used to transverse a 200 kV potential along the gradient bars of the high-voltage deck. Semi-rigid nylon tubing was selected for this application because unlike softer plastics long lengths remain uniformly round in cross-section. The transfer takes about two seconds, and the original tube is still in use after thousands of operations.

At the high voltage deck, the sample holder lodges in the hardened-steel insert of a stainless-steel water-cooled shaft as shown in Fig. 1 and is captured by two spring-loaded balls. Maintenance of the 3 atm Ar pressure for a few additional seconds after a transfer guarantees that the sample does not rebound out of this entrapment. After measurement in the source and retraction, the sample is returned to the magazine by applying reverse pressure at the shaft end to drive the sample holder back through the nylon tube to the magazine at ground potential.

2.4 The Vacuum Lock

The transfer shaft, which is driven pneumatically, is mounted horizontally and is free to slide back and forth through two stages of differential pumping (see Fig. 3). When the sample is slid into the ion source it stops at the Cs focus. The vacuum seals consist of three linear bearings¹⁾ whose surfaces are coated with a fluorocarbon liner. Air leakage

through these bearings under static conditions is very small. Two rotary-displacement pumps with pumping speeds of ~ 7 and 5 l/s provide the differential pumping and operate at cathode (sample) potential. Gas flow measurements with a water displacement flow meter indicate that 0.04 and 10^{-5} atm l/s of air are pumped by the first and second stages respectively. Leakage into the ion source is estimated to be 10^{-9} atm l/s under static conditions. The pressures are 0.8 , 0.005 and $<10^{-6} \text{ Torr}$ at the first and second pumping stations at and the ion source region of the sample changer, respectively. During sample changes, ion-source pressure excursions of up to 10^{-5} Torr are experienced for a few seconds due to trapped Ar in the transfer shaft. These have no effect on the high voltage performance of the source.

Horizontal sample position can be precisely adjusted with an external micrometer. Vertical adjustment is achieved by translating the linear bearing housing along a vertical slide. Once centred, no further adjustments have been required over several months of use.

2.5 The Ion Source

The ion source is illustrated in Fig. 4. It consists of a spherically-shaped Cs ionizer operating at about 8 kV with respect to the sample (cathode). The degree of Cs focusing is controlled with the Cs focus lens and is usually set to focus Cs^+ to a 0.5 mm diameter spot centred on the sample. Negatively-ionized sputtered ions are extracted through the ionizer, accelerated and mass analyzed twice (15 and 185 kV) before injection into the Chalk River MP tandem accelerator.

The ion source has been constructed with additional ports and feedthroughs to facilitate development work such as: temperature measurements of various components, vacuum measurements near the sample and the introduction of supplementary heaters or gas feeds. In particular, a Faraday cup has been mounted behind the sample to permit Cs^+ current measurements when the sample and shaft is withdrawn. Because the aperture plate behaves as a pin hole camera, an image of the Cs^+ source is formed at the Faraday cup and adjustments of the Cs focus lens can be monitored with the segmented Faraday cup shown in Fig. 4.

2.6 Control of Source and Sample Changer

AC power and control are provided at anode, cathode and ground potentials. Control is via a CAMAC-interfaced PDP-11 system. Sample-magazine control is from the ground-potential CAMAC crate; the Cs oven, ionizer heaters and Cs^+ focus lens are controlled by the anode-potential crate; and the differential pumping and sample changer obtain their power and control from the cathode deck and crate.

3.0 OPERATING EXPERIENCE AND FURTHER DEVELOPMENTS

The only commissioning problems encountered occurred with the pneumatic transfer of the sample from the magazine to the ion source. First, the long transfer tube was too deformed to pass the sample holder; this was overcome by replacing the polyethylene tubing with semi-rigid nylon tubing. The second problem involved the gumming of the sample holder by powder, likely an extrusion parting agent, present in the

nylon tube. The powder was removed by pulling a test-tube brush through the tube. Lastly, the length of the plastic tube was increased from 3 m to 15 m in order to prevent sparking along the tube.

In shuttling the sample holder back and forth from magazine to ion source it is essential that sample material not be lost. That this is the case has been demonstrated by inspecting and weighing the sample after shuttling one sample holder back and forth hundreds of times.

Typically, a current of 5 μA of $^{35}\text{Cl}^-$ is extracted from a Cl sample for about 15 μA of Cs^+ sputtering current. Although 50 μA of Cl^- can be easily extracted, this is not done because the Chalk River AMS system is not equipped with a beam attenuator to prevent accelerator beam-loading problems.

After a sample is inserted into the ion source, the Cl^- current always increases with time (see Fig. 5). Immediately after sample removal the ion source Cs^+ current decreases by as much as a factor of ten with time. Since no vacuum excursion takes place during sample removal, these current fluctuations are not related to vacuum conditions. Furthermore, Cs^+ current measurements with pure Au, Ag or Cu samples do not exhibit this effect but are stable with time. This suggests that the Cs ionizer work function and efficiency may be increasing with the deposition of sputtered Cl. Indeed, the same effect on Cs^+ and extracted negative-ion current is observed with bromide and iodide samples suggesting that halogens can improve the surface-ionization probability of hot surfaces for alkali elements. The ability to control this affect is presently under investigation.

Ion source memory (see an accompanying paper) is about 2 to 5 times higher than in the former ion source. Because the Cs halo is larger in this ion source, the effect is likely due to sputtering from contaminated surfaces adjacent to the sample. The halo is caused by lens aberrations experienced by the Cs⁺ ions originating from hot surfaces surrounding the Ta ionizer. A redesigned support structure is planned which will obviate the need for these peripheral surfaces.

Lastly, the new-found flexibility for inspecting and exchanging samples on-line has incurred the need for an increased excellence in book-keeping. Plans are in place to identify samples automatically. This can be done with a binary code that is machined as variable-depth grooves into the sample holder. The identification system, which has been shown to work on the bench, involves detecting laser light that is transmitted along the grooves. This method is preferred over a traditional bar-code reader because the signature is permanent—it won't peel, discolor or outgas, and it can be miniaturized beyond that presently available with bar codes.

4.0 SUMMARY

A simple sample changer and magazine have been constructed at Chalk River for AMS work. Because the magazine is external to the ion-source cage, samples may be inspected or exchanged during the course of measurements. Sample changing is performed without altering any source voltage. The ion source is of a versatile design with extra ports and feedthroughs facilitating development work.

REFERENCES

1. **Pacific Bearing Co., 200 Quaker Road, Box 6980, Rockford, Illinois 61126-6980.**

FIGURE CAPTIONS

Figure 1: The barrel-shaped sample holder and the trapping mechanism in the shaft. The figure on the left shows a cross section of the shaft; that on the right a rear view of a sample holder inserted in the shaft.

Figure 2: The sample magazine and its coupling to the pneumatic transfer tube. On the left is a vertical view; on the right a horizontal view. Samples can be individually exchanged in the magazine wells by lifting and swiveling the transfer tube over to one side and by lifting the sample out of the wheel with the spring-loaded plunger/supply tube. Magazine exchanges are also possible.

Figure 3: Cross-sectional view of the differential pumping stages defined by the linear bearings that permit the sample to slide from atmospheric pressure into high vacuum within seconds or vice versa.

Figure 4: Schematic illustration of the ion source with a spherical ionizer, Cs focus lens and segmented Cs-current Faraday cup.

Figure 5: Time-dependence of Cs^+ (open circles) and total extracted negative-ion (filled circles) currents from a AgCl sample. Initially, the extracted current grows. Upon sample removal the Cs^+ current is observed to be high but it quickly decreases. The magnitude of the Cs effect is related to the length of time the sample is withdrawn

from the ion source. The effect has been observed with AgCl, CuBr and AgI samples but not with Cu, Ag, or Au samples.

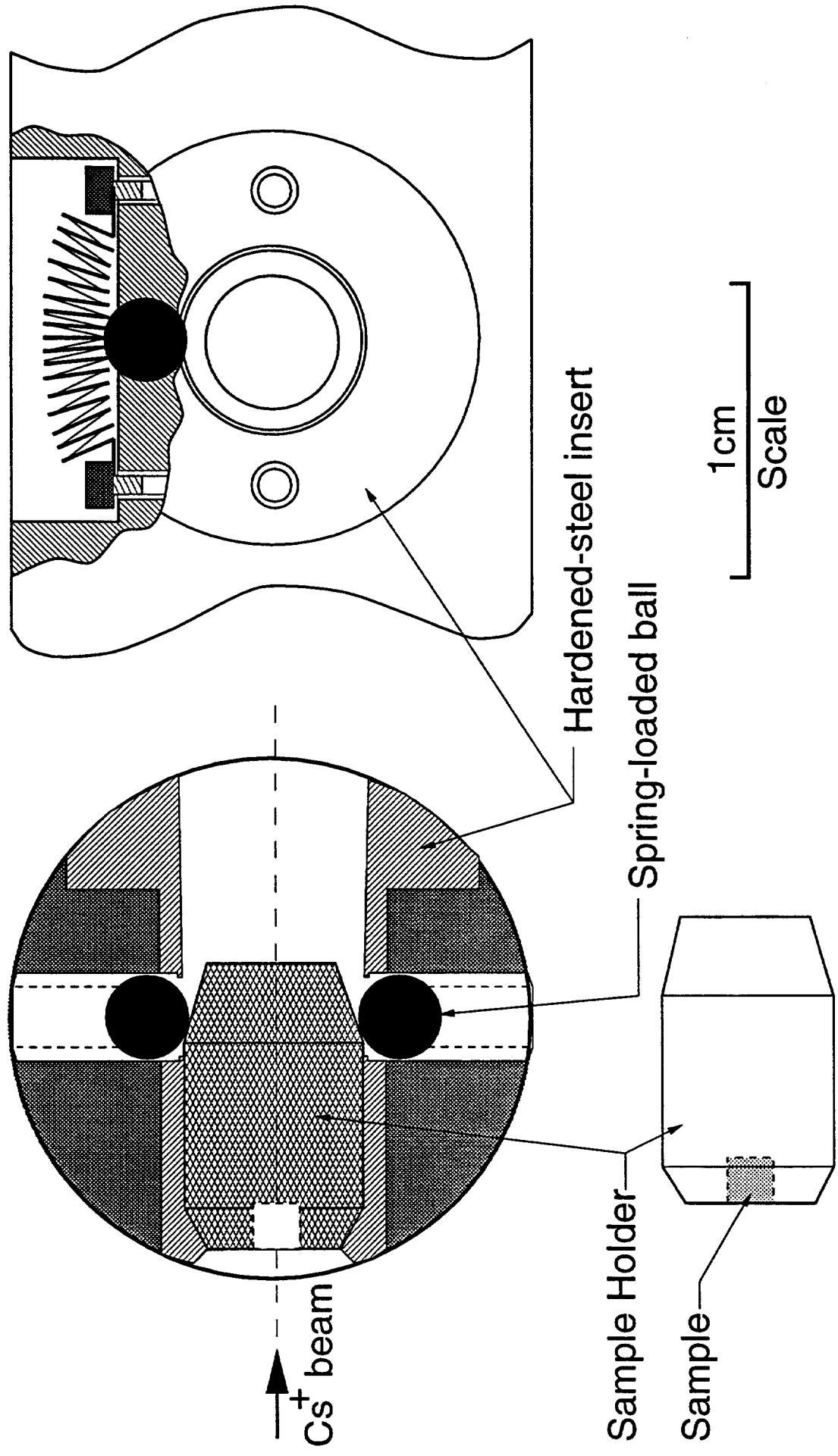

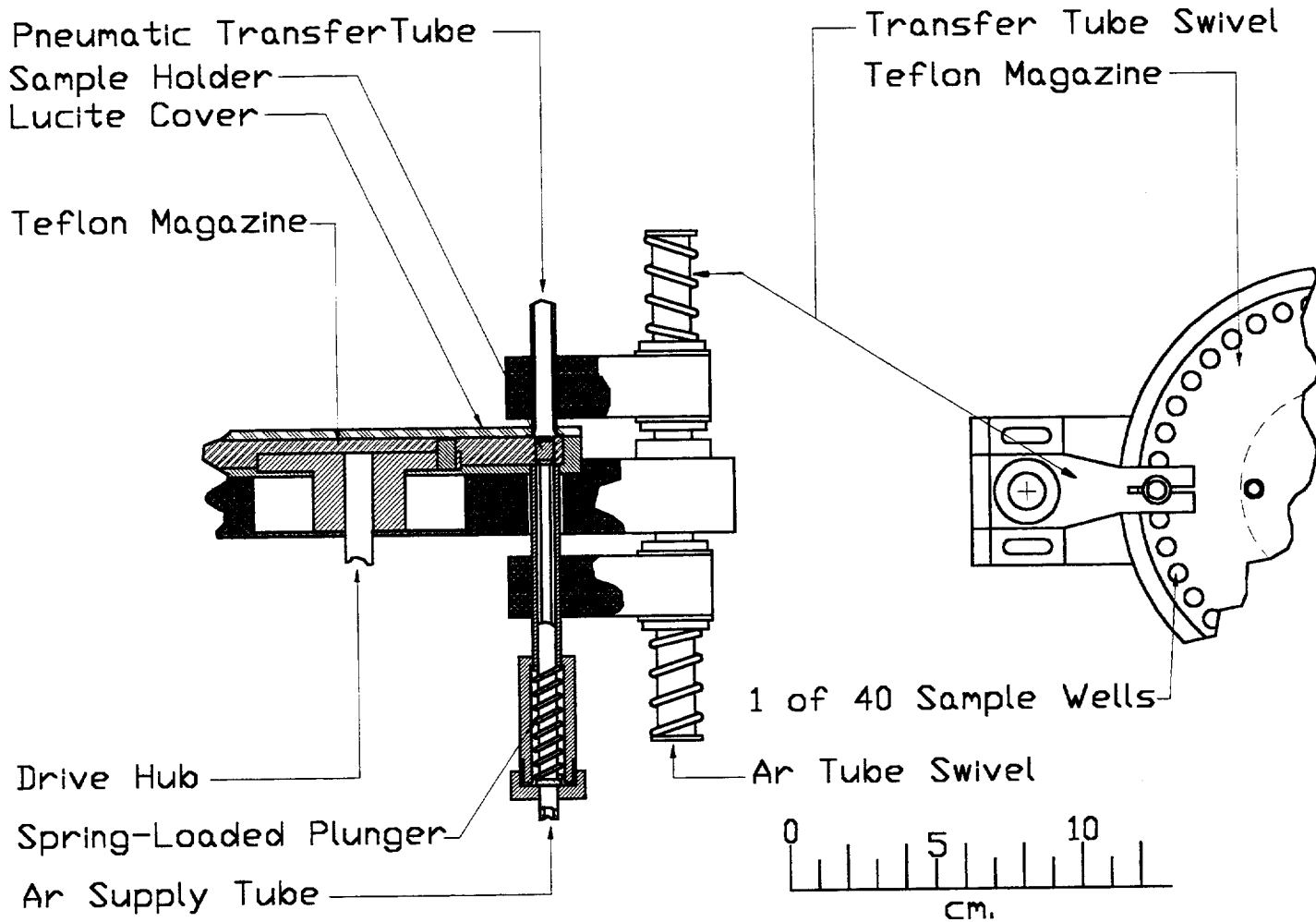

Fig 2

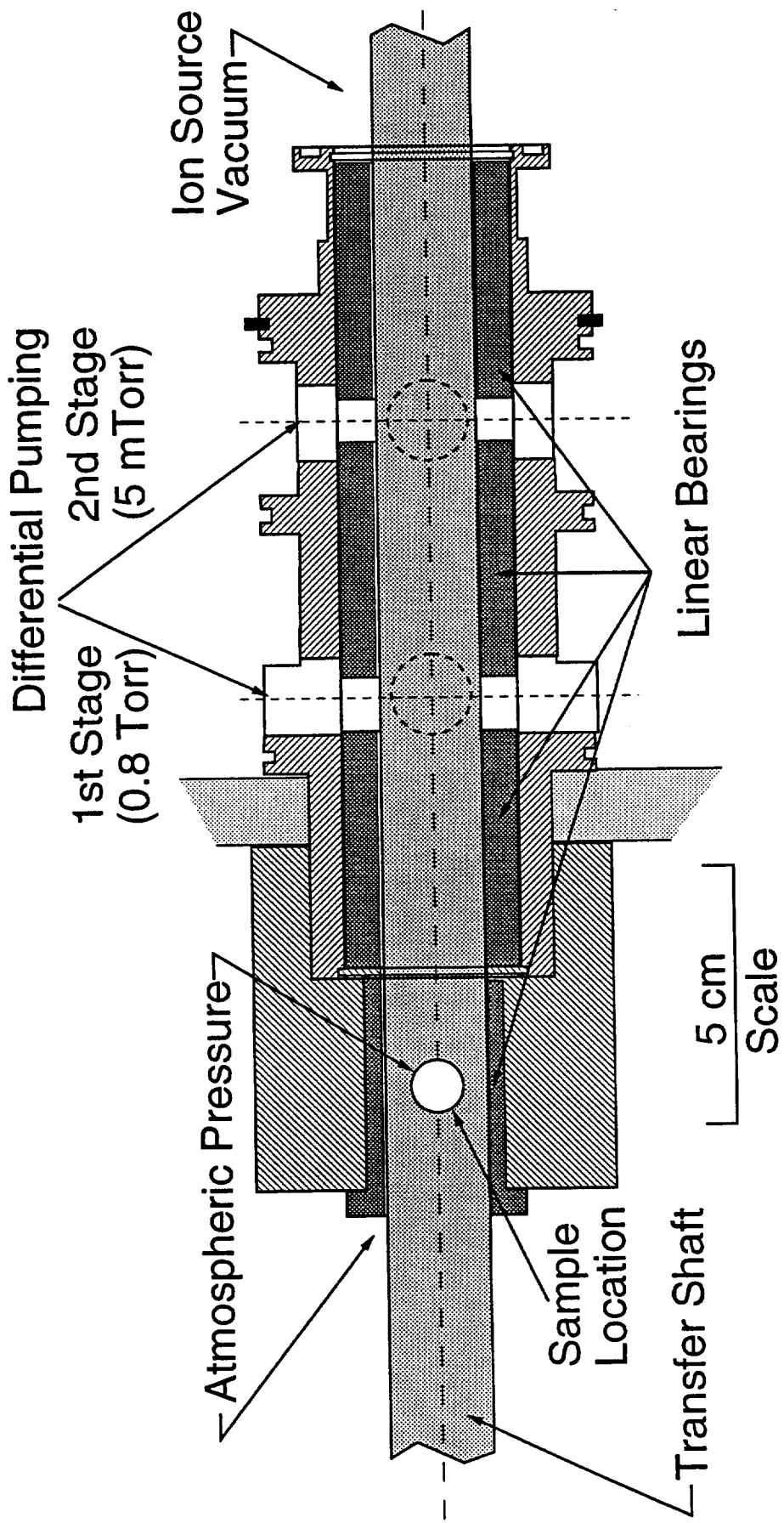

Fig 3

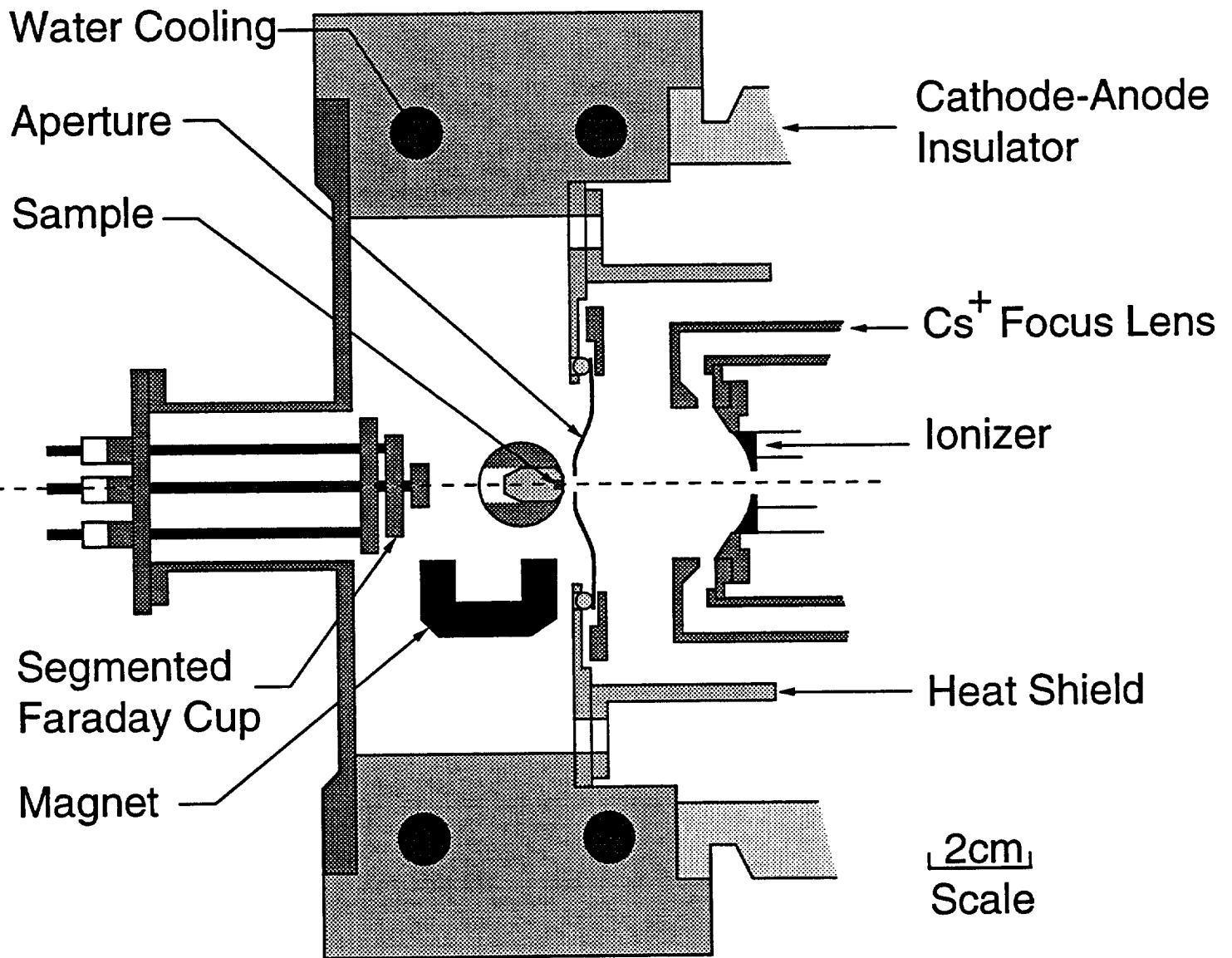

Fig 4

Time-Dependence of Cs and Negative-Ion Currents

AgCl Sample

