



The Compact Muon Solenoid Experiment
Conference Report

Mailing address: CMS CERN, CH-1211 GENEVA 23, Switzerland



22 October 2024

The Phase-2 CMS BRIL system for precision luminometry

Sophie Mallows for the CMS Collaboration

Abstract

The CMS Beam Radiation, Instrumentation and Luminosity (BRIL) system aims to provide high-precision bunch-by-bunch luminosity determination in the harsh conditions of the High-Luminosity LHC. Luminosity instrumentation will use diverse technologies, including a dedicated detector, the fast beam conditions monitor (FBCM) with Si-pad sensors and a fast triggerless readout. Various CMS subsystems back ends will be adapted to provide luminosity information, including the tracker endcap pixel detector (TEPX), the outer tracker, the muon barrel, the hadron forward calorimeter, as well as the 40 MHz trigger scouting system. The BRIL Trigger Board will enable the independent operation of FBCM and the innermost layer of TEPX from the rest of CMS at all times by providing a dedicated timing and luminosity trigger infrastructure.

Presented at *ICHEP2024 42nd International Conference on High Energy Physics*

The Phase-2 CMS BRIL system for precision luminometry

Sophie Mallows^{a,b,*}

^a*on behalf of the CMS Collaboration*

^b*Karlsruher Institut für Technologie (KIT),
Wolfgang-Gaede-Str. 1, 76131 Karlsruhe, Germany*

E-mail: sophie.mallows@cern.ch

The CMS Beam Radiation, Instrumentation and Luminosity (BRIL) system aims to provide high-precision bunch-by-bunch luminosity determination in the harsh conditions of the High-Luminosity LHC. Luminosity instrumentation will rely on several CMS subdetectors and subsystems, including a dedicated detector, the fast beam conditions monitor (FBCM) with Si-pad sensors and a fast triggerless readout. Various CMS subsystems' back-ends will be adapted to provide luminosity information, including the tracker endcap pixel detector (TEPX), the outer tracker, the muon barrel, the hadron forward calorimeter, as well as the 40 MHz trigger scouting system. The BRIL Trigger Board will send the luminosity triggers to the whole TEPX, and it will enable the independent operation of FBCM and the innermost layer of TEPX from the rest of CMS at all times by providing a dedicated timing and luminosity trigger infrastructure.

*42nd International Conference on High Energy Physics (ICHEP2024)
18-24 July 2024
Prague, Czech Republic*

*Speaker

1. Introduction

Luminosity Measurements at the HL-LHC

The High-Luminosity upgrade of the Large Hadron Collider (HL-LHC) aims to increase the peak instantaneous luminosity by a factor of approximately 5 to 7.5 compared to its original design. At the Compact Muon Solenoid (CMS) experiment, this will result in an average rate of interactions per bunch crossing, or pileup, of $\langle \text{PU} \rangle \approx 140\text{--}200$, compared to a peak pileup of around 60 during LHC Run 3. The accompanying Phase-2 upgrade of the CMS detector is designed to support efficient operation up to an integrated luminosity of 4000 fb^{-1} .

The measurement of instantaneous luminosity is essential in collider experiments, as it relates the event rate of a process to its cross-section. This is crucial for many physics measurements, both in Standard Model (SM) physics and in searches for new physics. In SM physics, luminosity measurements often represent the leading source of uncertainty, particularly in differential cross-section analyses, such as those involving Higgs boson production [1]. The physics objectives of the HL-LHC demand a highly ambitious luminosity precision of 1% following final calibrations, at which point it would become a secondary source of uncertainty in most analyses. Real-time, bunch-by-bunch measurements, which support beam optimization, the identification of beam instabilities and luminosity leveling, are expected to achieve a precision of 2%.

Requirements of a precision luminometry system

The more demanding conditions and tighter precision requirements of the HL-LHC era pose significant challenges for the Beam Radiation, Instrumentation, and Luminosity (BRIL) project, which is responsible for luminosity measurements at the CMS experiment. An ideal luminometer would provide a consistent linear response across the full dynamic range of pile-up and deliver sufficient bunch-by-bunch measurements to achieve sub-percent statistical precision during low-pile-up runs, particularly in special fills used for absolute luminosity calibration via the van der Meer (vdM) method. Additionally, it should maintain stable, long-term performance throughout the data collection period and be capable of continuous operation, independent of the status of other subsystems, including the central trigger and data acquisition systems, allowing for measurements during commissioning and development phases and enabling the publication of online luminosity, even when other CMS subsystems are not operational.

Phase-2 Strategy: Subsystems for luminosity measurements at the HL-LHC

In practice, no single monitor is perfect, so CMS luminosity measurements rely on a network of monitors to enable cross-verification and ensure reliability through redundancy. In principle, any data source that demonstrates a linear relationship with pileup can be used to measure luminosity. The Phase-2 strategy [2] therefore involves maintaining and upgrading existing detectors, developing new instrumentation, and implementing specialized data processing for the back-end of other CMS detectors.

The subsystems utilized for measuring luminosity at the HL-LHC, are depicted in figure 1. These include the Tracker Endcap Pixel Detector (TEPX), and in particular its Disk 4 Ring 1 (D4R1), which is operated independently of the tracker, all providing pixel cluster counts. Next the Outer Tracker Layer 6 (OT L6), which delivers two-fold hit coincidence (stub) counts. The Hadron

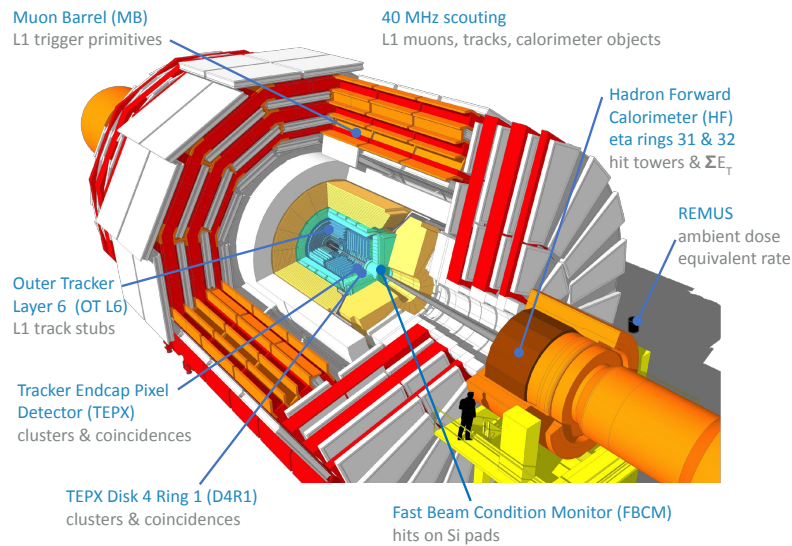

Figure 1: Subsystems to measure luminosity at the CMS Detector

Forward (HF) calorimeter measures occupancy and the sum of transverse energy. The muon system, particularly the Drift Tubes (DT), offers track candidate (stub) counts. The RAMSES detectors, part of the CERN Radiation Protection REMUS scheme demonstrated linearity with high pileup and were successfully used in cross calibrations for Run 2 luminosity data. Finally, the 40 MHz first-level (L1) trigger scouting captures track, muon, and calorimeter cluster data.

Central to the operation of BRIL luminometers is the BRIL trigger board (BTB) as described in the following section, the Common Histogramming Unit (CHU), and BRIL Data and Acquisition (BRIL DAQ) for data forming and storage. The CHU is a crucial component for enabling the use of data from other CMS subsystems for luminosity measurements. It is implemented as a stand-alone firmware block that can be hosted into any subdetector back-end module; the core architecture is not expected to change from Phase-1, although almost all inputs will change.

2. The BRIL Trigger Board

The BRIL Trigger Board (BTB) plays a crucial role in the Phase-2 upgrade of the CMS experiment. It is based on the CMS Serenity platform, an ATCA (Advanced Telecommunications Computing Architecture) carrier card developed for high-performance data processing. The BTB facilitates the distribution of high-precision timing and luminosity trigger signals, which are synchronized with the 40 MHz LHC clock. The BTB receives the LHC clocks and orbit signals, and the discriminated signal from the LHC Beam Pick-up Timing for Experiments (BPTX), from which the fill pattern is identified and forwarded to the CMS Global Trigger (GT). Using this data, the BTB generates luminosity triggers and forwards them to all CMS subsystems. It also generates local trigger and timing streams for the independent FBCM and D4R1 luminometers.

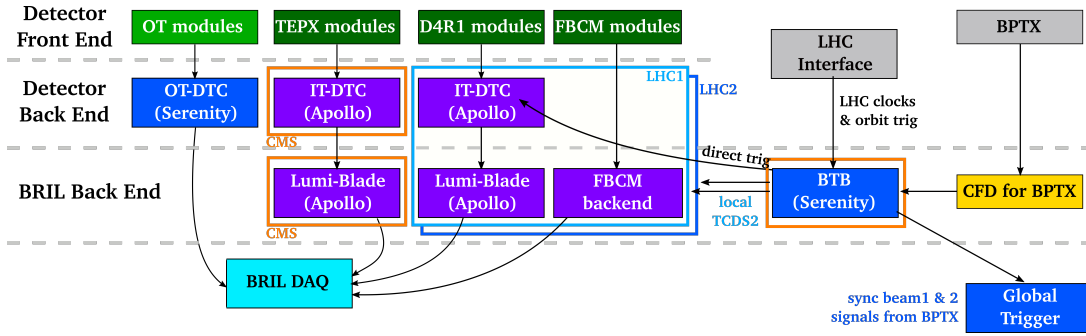

Figure 2: Simplified Schematic of the BRIL Trigger Board in relation to other BRIL and CMS subsystems

3. Luminometers

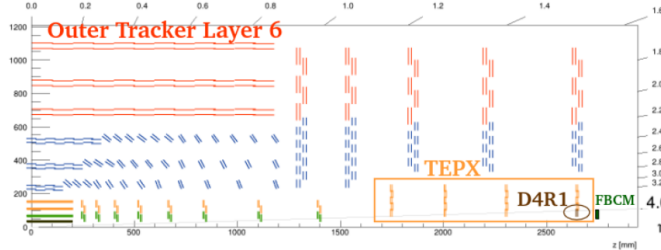

Figure 3: Location of four Phase-2 luminosity subsystems on tracker layout

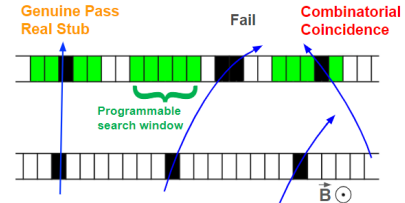

Figure 4: Representation of stub counting in OT6

Tracker Endcap Pixel Detector

The Real-time Pixel Cluster Counting (PCC) system will operate on 800 million pixels, covering a total area of 2 square meters of silicon, with occupancy below 0.1%. The system will utilize FPGAs to perform real-time cluster counting based on luminosity triggers, which will amount to about 10% of the physics trigger bandwidth (i.e. ~ 75 kHz of trigger rate) for main TEPX, while the full 750 kHz trigger rate will be available for D4R1. The detector data will be transmitted from the inner tracker back-end board to a dedicated processor board for real-time clustering. Simulations have confirmed the linearity of the system's performance up to a pileup value of 200.

Tracker Endcap Pixel Detector Disk 4 Ring 1

D4R1, located beyond the pseudorapidity threshold of $\eta = 4$, will not be utilized for tracking purposes. It can therefore be operated as a fully independent luminometer, featuring front-end optimization and a dedicated back-end trigger. The system is designed to be continuously operational, providing essential beam background and luminosity measurements during machine development, commissioning, and the entire filling cycle, including the ramping phase. The full trigger bandwidth allocated for BRIL is about 750 kHz at a pileup of 200, with a capacity between 2 to 4 MHz at lower pileup conditions. Simulations have demonstrated the system's linearity up to a pileup of 200.

Tracker Outer Layer 6

The outer tracker layer 6 (OT6) is composed of 72 sensor ladders on each end of the CMS detector, with each ladder containing 12 modules. Luminosity is measured through an untriggered

40 MHz readout of stubs, which are reconstructed coincidences of two sensors, as shown in figure 4. The stub counts per ladder will then be histogrammed from within the OT backend modules using the BRIL common histogramming firmware. To address a known and well-understood quadratic component in stub dependency on pileup caused by random coincidences, solutions are currently being developed. One approach is to exploit online observables linked to the non-linear component (such as stub bend) so to constrain it. Another promising approach is to cross-calibrate stubs with cluster data, which exhibit linear dependence.

Although OT6 will not provide luminosity measurements outside of global CMS data-taking, this method is estimated to offer the highest statistical power and is expected to provide a highly reliable independent measurement.

Fast Beam Conditions Monitor

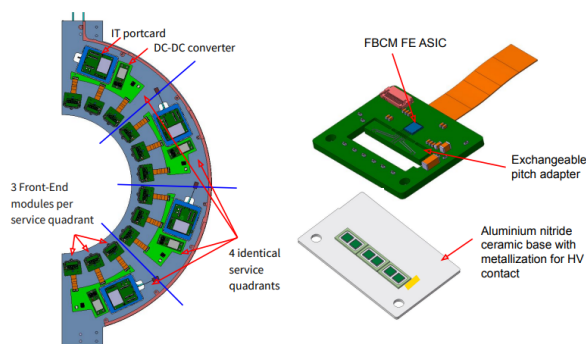

Figure 5: FBCM half-disk (left), with the mounted front-end module and Aluminium-Nitride ceramic base-plate with three two-pad silicon sensors (right).

The FBCM [4] is a stand-alone luminosity monitor that is completely independent of CMS services such as DAQ, Run control, magnet status, and, as with D4R1, will be available outside stable beams for data taking and background measurements during LHC commissioning. The system consists of two half-disks located on each side of the interaction point (IP), positioned behind TEPX Disk 4 at a radial distance of ~ 14.5 cm and a longitudinal distance of $|z| \sim 285$ cm. It can be accessed and/or replaced much more easily than the other systems, and its performance is highly tolerant against loss of individual channels. It consists of 288 1.7×1.7 mm² silicon-pad sensors read out using a dedicated front-end ASIC. Each half-disk is composed of four identical service quadrants, each with an inner tracker port card, a DC-DC converter and a service board to route the voltage lines to 3 front end modules. The system employs a trigger-less, asynchronous readout mechanism that is both fast and characterized by low noise, providing nanosecond-level time resolution. The mechanical design follows that of the inner tracker, utilizing similar materials and manufacturing techniques, with minor modifications. It operates as an independent ring but is connected to the TEPX cooling manifold. At a pileup of 200, the system is expected to achieve a rate of 0.1 hits per sensor per bunch crossing and employs a zero-counting technique for its measurements. At the time of the ICHEP conference, the mechanical design of the half-disk was finalized, tests for the characterization of dedicated ASIC had been successfully completed [5], and front end modules were in the process of being evaluated at CERN test beams.

The Hadron Forward Calorimeter, BMTF and 40 MHz Scouting

The Hadron Forward (HF) Calorimeter has served as a key luminometer during Phase-1. It detects Cherenkov light generated in quartz fibers embedded within a steel absorber. Optimal linearity is achieved by two rings within the pseudorapidity range of $|\eta| = 3.15$ to 3.50 , whose signals are processed using dedicated electronics integrated into the BRILDAQ system. The HF μ TCA backend employs two algorithms, one which measures occupancy above a defined threshold (HFOC), while the other calculates the transverse energy sum (HFET). While major modifications are not planned, Phase-2 development efforts are focused on enhancing radiation tolerance and improving linearity of response at high pileup.

The barrel muon track finder (BMTF) provides orbit-integrated muon candidate rates real time at the L1 trigger for 23 s time intervals. During Run 2, the BMTF demonstrated excellent linearity and stability, along with an almost background-free measurement capability, due to its design and trigger algorithms that effectively filter out noise and irrelevant signals. In Run 3, the BMTF has maintained these characteristics, with updates primarily aimed at handling the increased luminosity and collision rates.

The 40 MHz scouting system is being developed to not only extend data collection capabilities but also to serve as a highly effective luminometer, where an average number of objects is a measure of luminosity. The extensive data flow from the L1 trigger will potentially offer good statistics, ensuring high-precision luminosity measurements.

4. Summary

To achieve the CMS HL-LHC luminosity measurement goal of 1% offline precision (and 2% online), multiple independently-calibrated luminometers will be utilized, including both CMS subsystems with dedicated luminosity readouts and a standalone monitor (FBCM). The FBCM adds robustness in terms of operational flexibility and maintainability. Studies from LHC Run 2 and Run 3 have shown that sub-percent statistical and linearity uncertainties are achievable under HL-LHC conditions. Currently, the core development is focusing on the new BRIL back-end for tracker luminosity and luminosity triggering, while for FBCM its mechanical design has reached an advanced stage and front-end tests are ongoing. The data acquisition system, BRILDAQ, will also evolve to handle an expanded set of luminosity sources and increased storage requirements.

References

- [1] CMS Collaboration. Measurement of Higgs boson production cross-sections and couplings. CMS Public Results, Preliminary Analysis HIG-23-013, 2023.
- [2] CMS collaboration, The Phase-2 Upgrade of the CMS Beam Radiation Instrumentation Detectors, Tech. Rep., CERN, Geneva, <https://cds.cern.ch/record/2759074> (2021).
- [3] M. Haranko, G. Auzinger, et al. on behalf of the CMS collaboration, TEPX as a high-precision luminosity detector for CMS at the HL-LHC, JINST 17 (2022) 03, C03001
- [4] G. Auzinger et al., The Fast Beam Condition Monitor for HL-LHC, Journal of Instrumentation (JINST), 2024, DOI: 10.1088/1748-0221/19/03/C03048
- [5] J Kaplan et al. The optimization, design and performance of the FBCM23 ASIC for the upgraded CMS beam monitoring system, 2024 JINST 19 C02026