

AK/ab

CERN/MPS/SR 71-7
10.3.1971MEASUREMENT OF THE MAGNETIC PULSE PERFORMANCE OF K.M. 97

A. Krusche and B. Nicolai

1. Introduction

During the 1969 PS shut-down the high voltage pulse generators (pulse forming networks + spark gaps) providing the fast current pulses for the Kicker Magnet (KM) in ss 97^{1,2)} were modified to achieve better rise time and pulse length of the magnetic kick. To adjust the form of the integral magnetic field pulse (kick) the built-in pick-up was used. But observing some irregularities we were not sure to distinguish between imperfections of the KM response and errors due to the measuring device. In the meantime, discussions arose about the kick quality needed to fit the fast ejection requirements for the ISR. Therefore, measurements were made using a special pick-up which was developed for laboratory use.

2. Measuring arrangement

Normally a fast magnetic pulse is measured by means of an adequate coil. In the case of a fast delay line kicker magnet attention must be paid to errors introduced by the signal travelling time in the pick-up itself and, as we discovered recently, by capacitive coupling of the measuring coil to the voltage pulse exciting the magnet.

In order to reduce the time distortion in the measuring coil to a minimum, multiple reflections must be avoided. This can easily be done by a fully matched construction, e.g. by a strip line matched to the signal transmission cable impedance.

The capacitive coupling between measuring coil and voltage pulse passing the magnet becomes important in the case of a small aperture delay line magnet, for it seems impossible to place the coil symmetrically with respect to the electrical field.

In order to get an idea of the capacitive effect, a simple measurement can be made. Assuming a fully matched pick-up and with the notation

a_m = voltage amplitude due to magnetic flux change
after integration (kick amplitude)

a_c = voltage amplitude due to capacitive coupling
after integration

we obtain: $a_{1,2} = \pm a_m + a_c$

for the total pick-up signal amplitude, depending on the kick direction, as only a_m changes the sign.

For a typical measurement situation we got:

$$|a_1| = a_m + a_c \approx 500 \text{ mV}$$

$$|a_2| = -a_m + a_c \approx 350 \text{ mV}$$

From this the magnitude of the capacitive influence determines to

$$\frac{a_c}{a_m} \approx 17 \%$$

Hence, some considerations about what one measures with such a device may be useful.

We now assume a pick-up in form of a strip line as shown in Fig. 1.

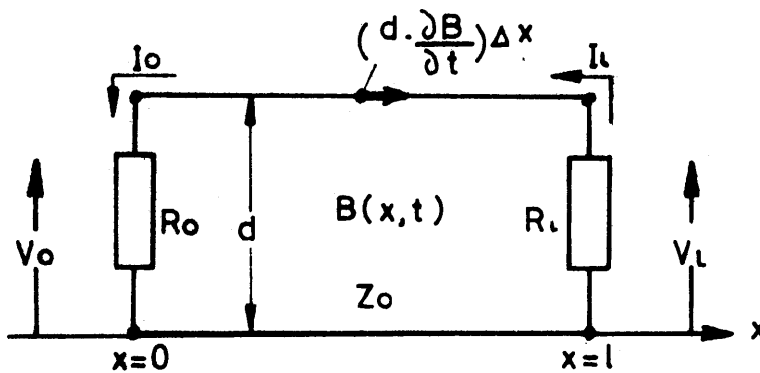

Fig. 1

For a lossless line with inductance L , capacity C per unit length, and width d , the differential equations for the current and voltage can be written as

$$L \frac{\partial I}{\partial t} - d \cdot \frac{\partial B}{\partial t} = - \frac{\partial V}{\partial x} \quad (1)$$

and

$$C \frac{\partial V}{\partial t} = - \frac{\partial I}{\partial x} \quad (2)$$

where all variables are functions of x and time. The term $d \cdot \frac{\partial B}{\partial t}$ is the magnetically induced voltage per unit length in the series portion of the line.

Using the Laplace transforms

$$\mathcal{L} \left[\frac{\partial F(x,t)}{\partial t} \right] = - F(x,t=0) + p\bar{F}(x,p) \quad (3)$$

and

$$\mathcal{L} \left[\frac{\partial F(x,t)}{\partial x} \right] = \frac{d\bar{F}(x,p)}{dx} \quad (F \text{ stands for } I, V, B) \quad (4)$$

and assuming no initial charge and currents, the partial differential equations can be reduced to the following ordinary differential equations in x ³⁾:

$$\frac{d^2 \bar{I}}{dx^2} - LCp^2 \bar{I} = - C \cdot d \cdot p^2 \cdot \bar{B} \quad (5)$$

$$\bar{V} = - \frac{1}{pC} \frac{d\bar{I}}{dx} \quad (6)$$

The boundary conditions are

$$\bar{I}_0 R_0 = - \bar{V}_0; \quad \bar{I}_l R_l = \bar{V}_l \quad (7)$$

where $\bar{I}_0, \bar{V}_0 = f(x=0,p)$ and $\bar{I}_l, \bar{V}_l = f(x=l,p)$.

We consider now the case of a magnetic travelling wave with linear rise time, entering the measuring loop from the left side. The travelling wave can be described by

$$B = \frac{B_0}{\tau_r} \left[\left(t - \frac{x}{\ell} T \right) H\left(t - \frac{x}{\ell} T \right) - \left(t - \tau_r - \frac{x}{\ell} T \right) H\left(t - \tau_r - \frac{x}{\ell} T \right) \right] \quad (8)$$

where τ_r = rise time of the wave
 T = travelling time in the kicker magnet
 $H(t-a)$ = Heaviside function

and its Laplace transform

$$\bar{B} = \frac{B_0}{\tau_r} \cdot \frac{1}{p} \left[e^{-\frac{x}{\ell}Tp} - e^{-(\tau_r + \frac{x}{\ell}T)p} \right] \quad (9)$$

In order to get the real kick as a function of time we start with

$$\frac{\partial K(x,t)}{\partial x} = B \quad (10)$$

With (4) we obtain the Laplace transform of the kick

$$\bar{K}(x,p) = \int_0^{\ell} \bar{B} dx \quad (11)$$

and therefore the kick itself :

$$K(t) = \frac{B_0 \ell}{2\tau_r T} \left[(t-\tau_r-T)^2 H(t-\tau_r-T) - (t-T)^2 H(t-T) - (t-\tau_r)^2 H(t-\tau_r) + t^2 \cdot H(t) \right] \quad (12)$$

To calculate the signal induced in the measuring loop we use equations (5), (6), (9) together with the boundary conditions (7). First we consider the fully matched loop, which means that

$$R_0 = R_{\ell} = Z_0 = \sqrt{\frac{L}{C}} .$$

Substituting $\Phi_0 = d \cdot l \cdot B_0$ for the maximum magnetic flux in the measuring loop we obtain for the induced voltage

$$V_0(t) = - \frac{\Phi_0}{2(T+\tau)\tau_r} \left\{ t \cdot H(t) - (t-\tau_r)H(t-\tau_r) - (t-\tau-T)H(t-\tau-T) + (t-T-\tau-\tau_r)H(t-T-\tau-\tau_r) \right\} \quad (13)$$

where τ = propagation time in the measuring loop.

After integration the signal has the form $a_m(t) = \int V_0 dt$ which is an image of $K(t)$. The various pulse forms are shown in Fig. 2, assuming $T > \tau_r > \tau$.

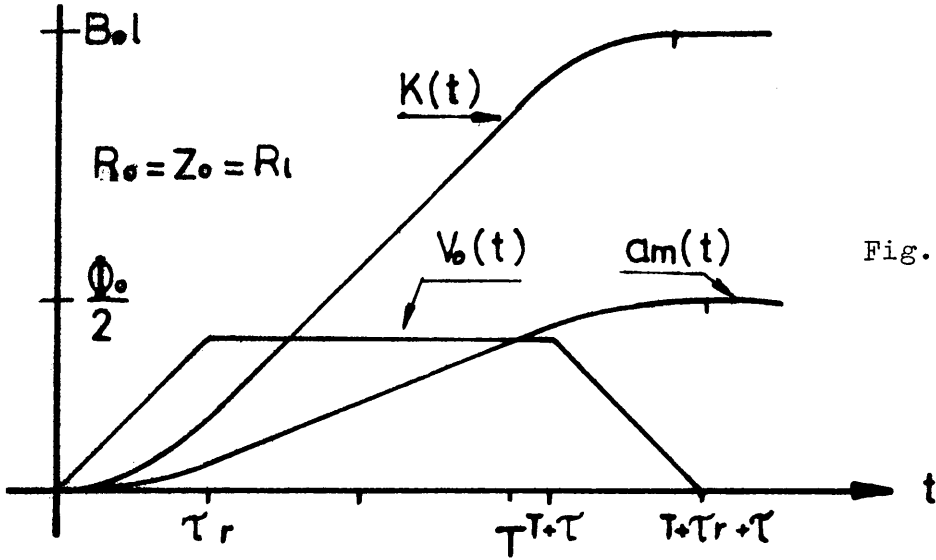

Fig. 2

If one end of the measuring loop is short-circuited ($R_l = 0$, $R_0 = Z_0$), we obtain for the measured signal :

$$V_0(t) = - \frac{\Phi_0}{2(T+\tau)\tau_r} \left\{ t \cdot H(t) + \frac{T+\tau}{T-\tau} (t-2\tau)H(t-2\tau) - \frac{2T}{T-\tau} (t-T-\tau)H(t-T-\tau) - (t-\tau_r)H(t-\tau_r) - \frac{T+\tau}{T-\tau} (t-2\tau-\tau_r)H(t-2\tau-\tau_r) + \frac{2T}{T-\tau} (t-T-\tau-\tau_r)H(t-T-\tau-\tau_r) \right\} \quad (14)$$

Assuming again $T > \tau > \tau_r$, Fig. 3 gives the pulse shapes for $V_o(t)$ and $a_m(t)$ in comparison with $K(t)$.

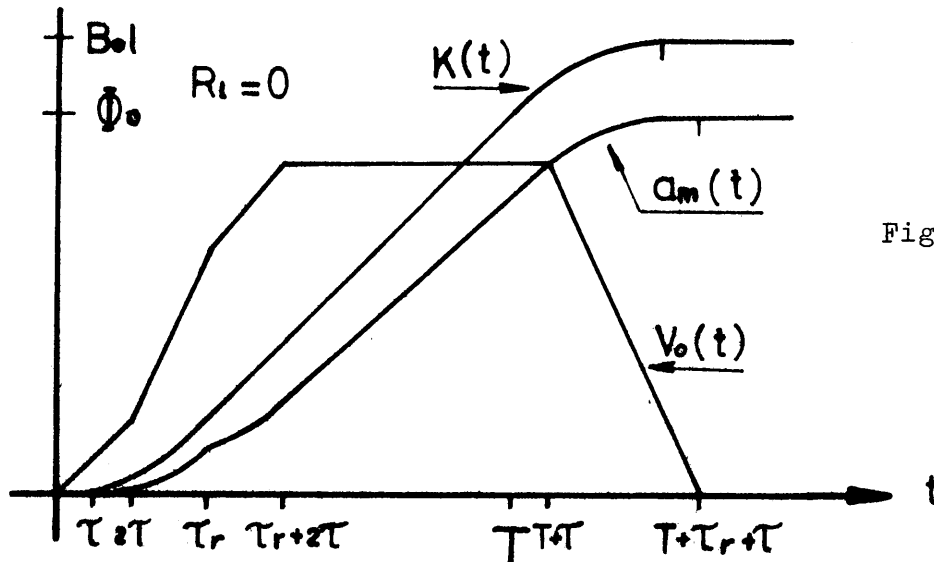

Fig. 3

Analyzing figures 2 and 3 we can see that in both cases the time error introduced by the measuring device is equal to the propagation time in the loop, but in the short-circuited case there is more distortion in the beginning of the pulse.

A rather complete investigation of pick-up problems was given recently by H. Riege⁴⁾, studying the effect of mismatching, too.

In order to get an idea of the capacitive effect in such a pick-up, we start with an equivalent circuit conformable to Fig. 4.

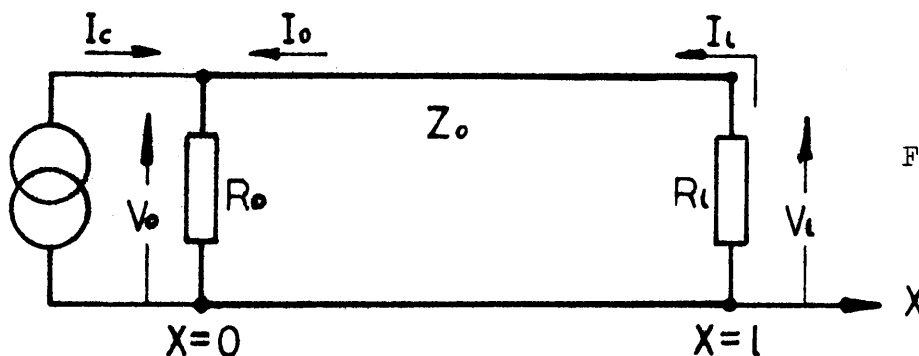
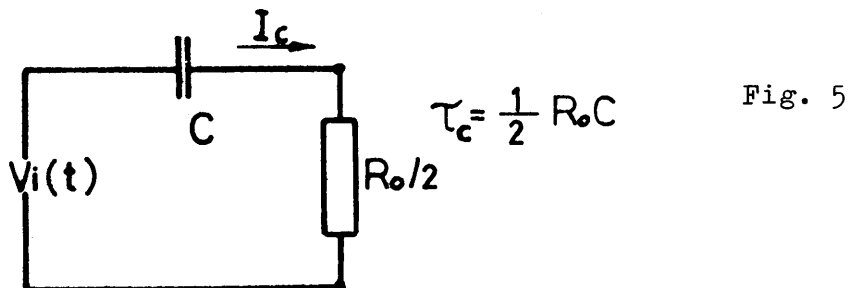

Fig. 4

Here I_c is a capacitively induced current, for simplicity determined by the circuit as shown in Fig. 5.



We use again equations (5) and (6), setting $\bar{B} = 0$, together with new boundary conditions

$$\bar{V}_o = -R_o \cdot \bar{I}_c - R_o \bar{I}_o; \quad \bar{V}_\ell = R_\ell \cdot \bar{I}_\ell \quad (15)$$

In case of $R_o = Z_o = R_\ell$ (matched loop) we simply obtain

$$\bar{V}_o = -R_o \cdot \frac{\bar{I}_c}{2}; \quad (R_o = Z_o = R_\ell) \quad (16)$$

and for the short-circuited loop

$$\bar{V}_o = -R_o \cdot \frac{\bar{I}_c}{2} \left(1 - e^{-2\tau p} \right); \quad (R_o = Z_o; \quad R_\ell = 0) \quad (17)$$

where τ = propagation time in the measuring loop.

Though the pulse shape of the electrical pulse "seen" by the pick-up is not well known, we assume $V_i(t)$ to have a linear rise time

$$V_i(t) = \frac{V_m}{\tau_r} \left[t \cdot H(t) - (t - \tau_r) H(t - \tau_r) \right] \quad (18)$$

Then it follows from Fig. 5 that

$$\bar{I}_c = \frac{2V_m}{R_o \cdot \tau_r} \cdot \frac{1}{p(p + \frac{1}{\tau_c})} \left(1 - e^{-\tau_r p} \right) \quad (19)$$

Using (16) and (17) we get after inverse Laplace transformation:

$$V_o = -V_m \cdot \frac{\tau_c}{\tau_r} \left[\left(1 - e^{-\frac{t}{\tau_c}} \right) H(t) - \left(1 - e^{-\frac{t-\tau_r}{\tau_c}} \right) H(t-\tau_r) \right] \quad \text{for } R_o = Z_o = R_l \quad (20)$$

and

$$V_o = -V_m \cdot \frac{\tau_c}{\tau_r} \left[\left(1 - e^{-\frac{t}{\tau_c}} \right) H(t) - \left(1 - e^{-\frac{t-\tau_r}{\tau_c}} \right) H(t-\tau_r) - \left(1 - e^{-\frac{t-2\tau}{\tau_c}} \right) H(t-2\tau) + \right. \\ \left. + \left(1 - e^{-\frac{t-\tau_r-2\tau}{\tau_c}} \right) H(t-\tau_r-2\tau) \right] \quad \text{for } R_o = Z_o; R_l = 0. \quad (21)$$

The signal pulse forms are shown in Figs. 6 and 7, together with the corresponding integrated signals, denoted as $a_c(t) = \int_0^t V_o dt$.

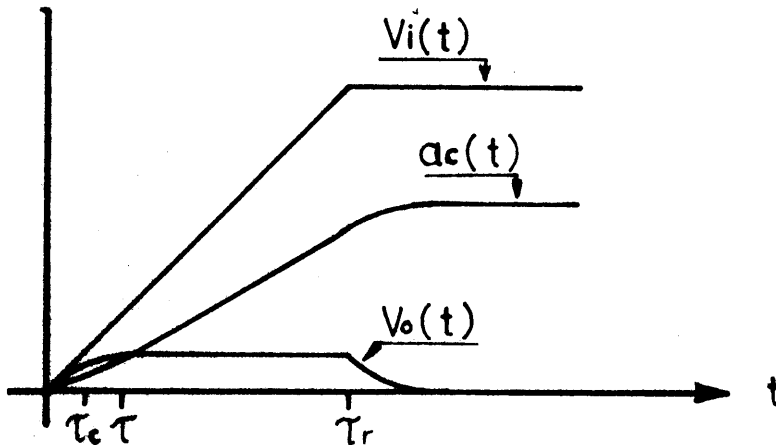

Fig. 6

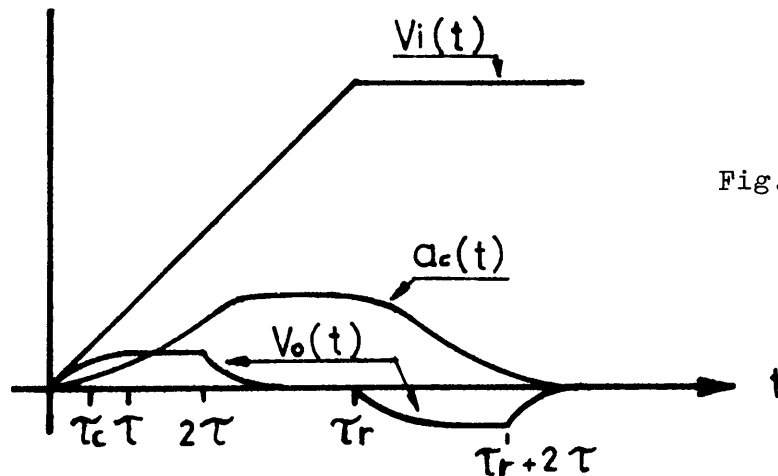

Fig. 7

From this we can deduce the following conclusions:

1. The capacitive effect in a matched pick-up changes the flat-top value of a measured magnetic kick. The measured kick rise time is strongly distorted and can be changed to shorter or longer values.
2. Measuring with a short-circuited pick-up the flat-top of the interesting magnetic kick is not influenced capacitively. The distortions during the kick rise time are reduced by approximately a factor of $k = \frac{2\tau}{\tau_r}$.
3. In both cases, i.e. matched and short-circuited pick-up, the time error is determined by the simple propagation time in the pick-up. The signal in the short-circuited pick-up is twice as high.

As a result, three short measuring coils were constructed covering completely the magnet aperture length. Each coil has a calculated propagation time $\tau = 1$ ns. With a voltage pulse rise time $\tau_r \approx 25$ ns (which approaches reality) the capacitive influence during the kick rise time is so reduced to about $\frac{a_c}{a_m} = k \cdot 17\% < 1.4\%$. The flat-top ripple should not be affected but in the very beginning.

The final pick-up arrangement is shown in Fig. 8.

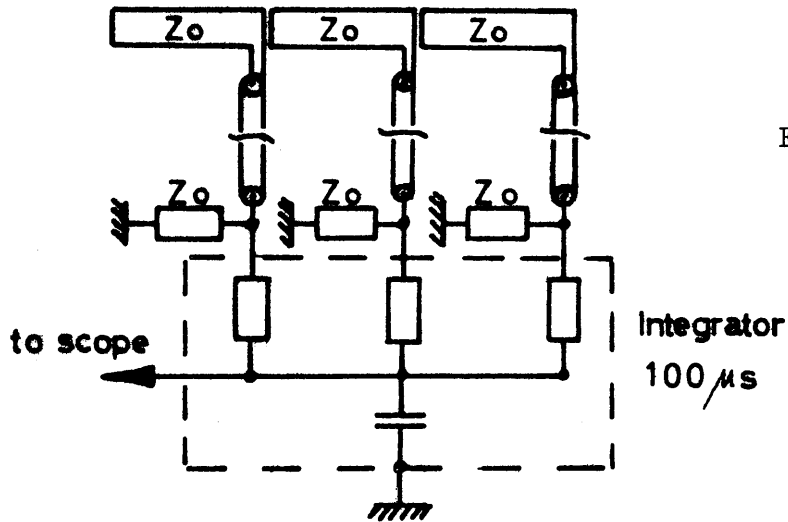

Fig. 8

3. Measurement results

The kick measurements were made for both magnet modules in ss 97. The high voltage pulse generators worked under the same conditions as during the PS run 1969/70. Only the applied voltage was changed to about a third of the highest value because of random discharges under measuring conditions. Nevertheless, the results are representative for the normal voltage values as well.

Figures 9 to 17 show some typical kick pulses when ejecting to different ejection zones (kick IN : ejection by septum 58 or 74; kick OUT : ejection by septum 16 to ISR).

Evaluating these pictures, the results for KM 97 are given below:

RISE TIME, measured from 5% to 100%

	Kick IN	Kick OUT
Module I	87 ns	85 ns
Module II	94 ns	95 ns
Average	$T = 91 \text{ ns} \pm 3$	$T = 90 \text{ ns} \pm 3$

MAXIMUM RIPPLE, measured on bunch positions

	Kick IN	Kick OUT
Module I	+ 10% - 3.7%	+ 6% - 2%
Module II	+ 0% - 1%	+ 1.5% - 2%
Average	+ 5% - 2.4% or $\frac{\Delta K}{K} \approx \pm 3.7\%$	+ 3.75% - 2% $\frac{\Delta K}{K} \approx \pm 3\%$

KICK gradient in first bunch position

$$\frac{dK}{dt} \approx 0.5 \left[\frac{\%}{ns} \right]$$

The flat-top of the pulse is taken as the 100% reference. The kick gradient in the first bunch position gives an idea of what happens when the kick has a time jitter with respect to the bunch structure.

Furthermore, it can be seen that mainly the 2nd, 10th and 12th bunches are influenced by the kick strength ripple. All other bunches are in positions where the kick strength is flat within $\sim \pm 1\%$. Figures 18 to 21 show also the fall time of the kick for several kick lengths. It can be seen that the bunch after ejection is affected considerably with 12 - 22 % of the total strength, depending on the kick length adjustment and on the number of ejected bunches.

4. Conclusions

Recent measurements of the kick performance of KM 97 showed that the maximum variation of the flat-top is in the order of $\pm 3\%$ when ejecting to the ISR. This relatively high value is mainly caused by a mismatching of one magnet module and by reflections in the system. The rise time of the kick pulse from 5% to 100% is found to be about 90 ns.

The present kick ripple is far away from the proposed value of $\pm 1 \%$ for fast ejection towards the ISR.* Nevertheless, the ISR needs seemed to be satisfied in all points up to now.

Comparing the results for the two KM modules it seems possible to adjust the worse module to about the same response as the better one, so that a flat-top within $\pm 2 \%$ could be achieved. The rather poor fall time of the kick can be explained by transmission cable distortions. Here only a falling edge sharpening switch (clipping gap) installed in the neighbourhood of the KM could lead to an improvement.

Distribution: (open)

MPS + SI Scientific and Technical Staff, upon request

*) In the meantime a value of $\sim \pm 2 \%$ is accepted, see ref. 5).

References

- 1) B. Kuiper and S. Milner
The new bare kicker magnet of the CPS fast ejection system
CERN/NPA/Int. 67-10

- 2) R. Bossart, H. van Breugel, L. Caris, H. Dijkhuizen, I. Kamber,
B. Kuiper, J. Leroux, S. Milner, B. Nicolai, E.M. Williams
Multiple short and multiple channel operation of the CPS fast
ejection system
CERN/PS/FES/Int. 69-9

- 3) J.C. Jaeger
Introduction to the Laplace transformation,
SCIENCE Paperbacks, Methuen & Co. Ltd., 1966

- 4) H. Riege
Some theoretical considerations about field loops for kick
measurements
CERN/PS/FES/TN-244

- 5) Minutes of a discussion on topics on the PS - ISR joint operation
24 November, 1970, MPS/CO - 7 Dec. 1970

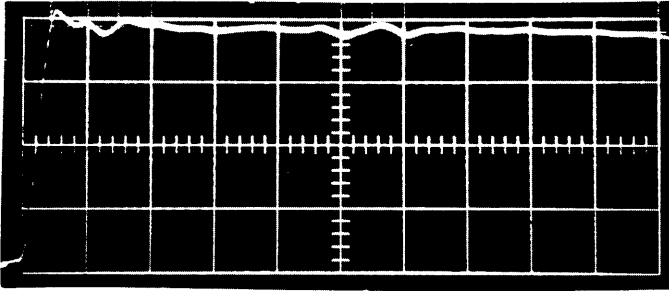

Fig. 9

KM 97, module II
kick OUT, 200 ns/div.

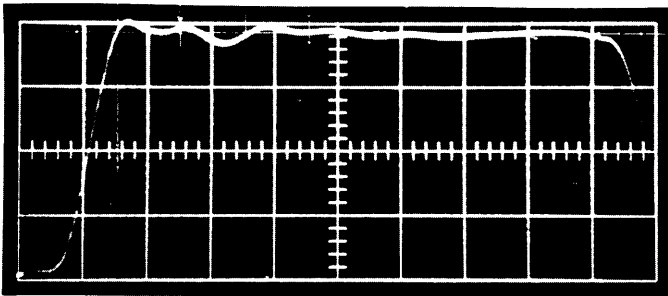

Fig. 10

KM 97, module II
kick OUT, 100 ns/div.

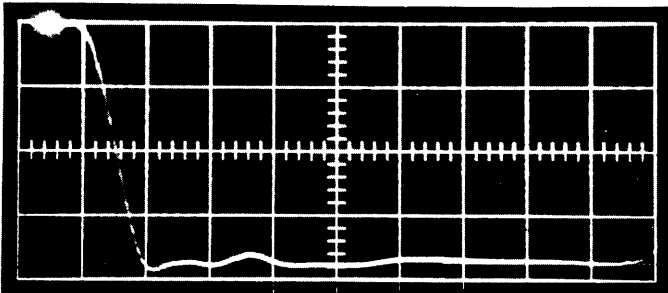

Fig. 11

KM 97, module II
kick IN, 100 ns/div.

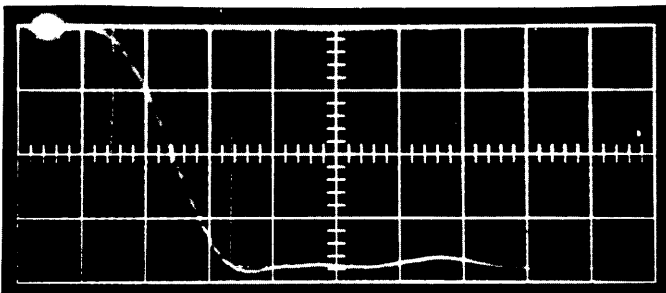

Fig. 12

KM 97, module II
kick IN, 50 ns/div.

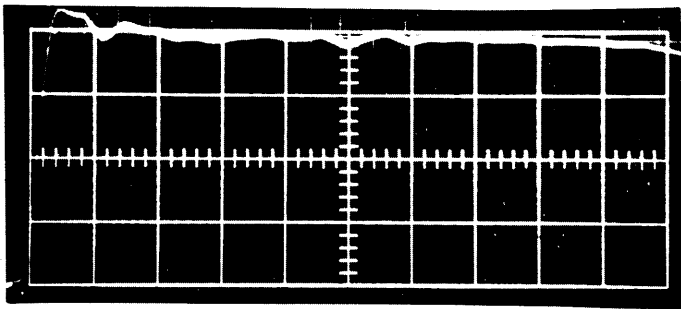

Fig. 13

KM 97, module I
kick OUT, 200 ns/div.

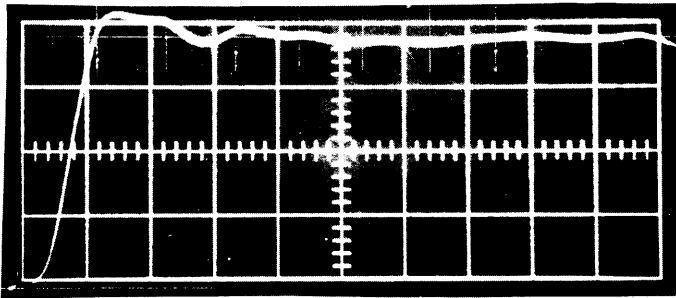

Fig. 14

KM 97, module I
kick OUT, 100 ns/div.

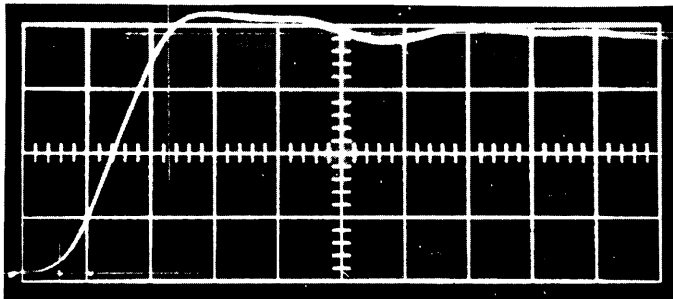

Fig. 15

KM 97, module I
kick OUT, 50 ns/div.

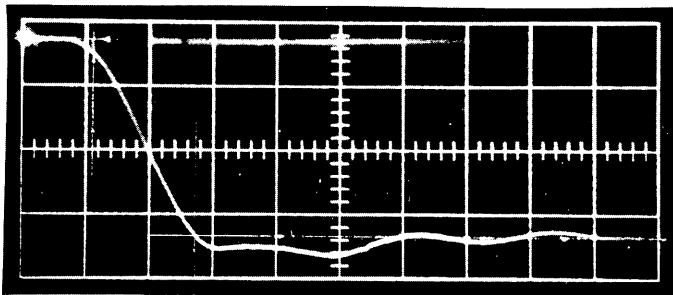

Fig. 16

KM 97, module I
kick IN, 50 ns/div.

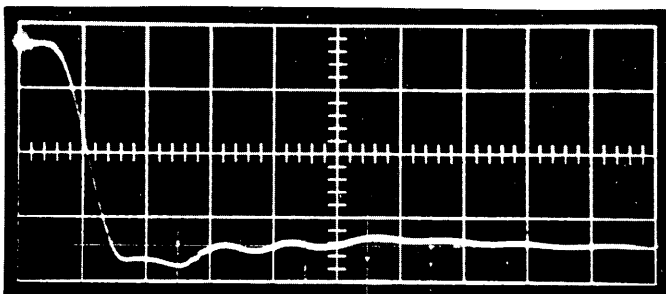

Fig. 17

KM 97, module I
kick IN, 100 ns/div.

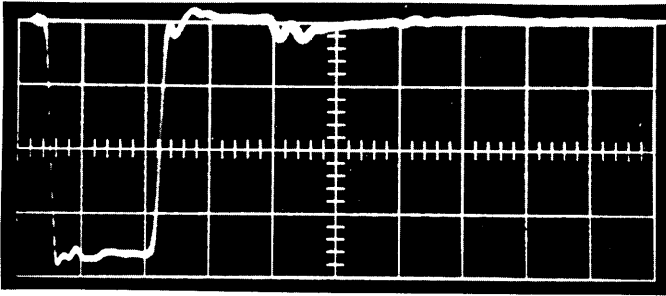

Fig. 18

KM 97, module II
kick IN, length 8 bunches
500 ns/div. **)

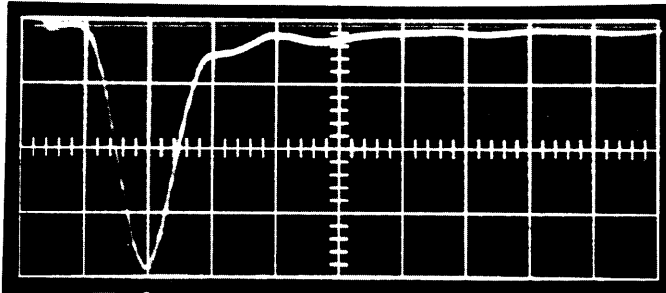

Fig. 19

KM 97, module II
kick IN, length 1 bunch
100 ns/div.

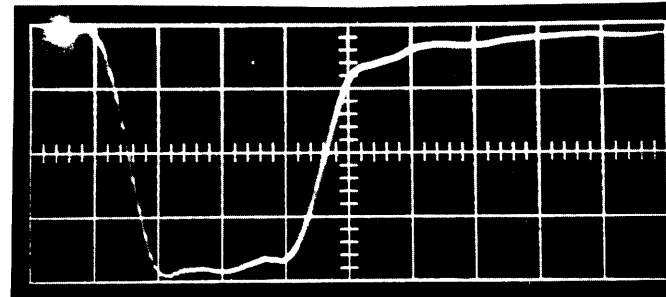

Fig. 20

KM 97, module II
kick IN, length 3 bunches
100 ns/div.

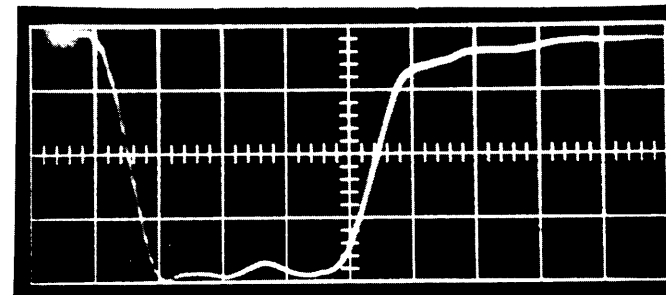

Fig. 21

KM 97, module II
kick IN, length 4 bunches
100 ns/div.

**) The kick lengths have not been really adjusted
for the indicated bunch number.