

**EUROPEAN ORGANIZATION FOR NUCLEAR RESEARCH
ORGANISATION EUROPEENNE POUR LA RECHERCHE NUCLEAIRE**

CERN - PS DIVISION

PS/ PA/ Note 94-32

Replaces

PS/BT Note 87-20

**SAFETY INSTRUCTIONS
FOR KFA45 PS INJECTION KICKERS**

H. Gaudillet

Geneva, Switzerland
1 November, 1994

SAFETY INSTRUCTIONS

FOR KFA 45 PS INJECTION KICKERS

H. Gaudillet

1. INTRODUCTION

This PS injection kicker system provides the fast beam deflection necessary for injection into the PS from the Booster transfer line.

Sections 4 to 6 of this instruction set concern isolation of the kicker system from all primary three-phase supplies. Isolation at this level removes the risk of high- and low-voltage contacts and therefore permits access to the equipment to all categories of personnel.

Section 7 defines the procedures necessary to remove the risk of dangerous parts, with others still energized.

2. DESCRIPTION OF THE KFA 45 SYSTEM

This system consists of four individual kicker magnets adjacently positioned in the ring, their associated pulse generators, and a common oil cooling system. A simplified block diagram is shown in Fig. 1.

The magnets are in Section 45 of the PS ring (see Fig. 2). The system comprises high- and low-voltage equipment located in building 365. Figure 3 shows the physical location of the different security components which will be referred to in this note.

The primary three-phase supply for the system is obtained from "armoire" T.I.K. N45-1-5-2 "départ" D1, located in building 365 (see Fig. 3). This supply is divided into six individual three-phase sub-system supplies in the fused switchboard, marked KFA-45 and located on the upper platform in building 365 (see Fig. 3).

All these sub-system supplies are breakable and can be locked off with individual Castell keys.

The connections and labelling of the three-phase switched supplies are shown in Fig. 4.

A special locking system attached to the switchboard allows to take a Castell key marked KFA 45 when the first five keys have been taken out of the switchboard (generators and oil system isolated) and locked back into the corresponding location in this special key box. After the KFA 45 key has been taken out it becomes impossible to remove the other five keys.

Modules 1, 2, 3 and 4 consist each of two high-voltage switch tanks named main switch (MS) and dump switch (DS). The MS tanks are located on the lower level of the building with the oil pumping system, while the DS tanks are on the upper level with the HV transformers. All the electronic racks belonging to the kicker generators are on the mid level.

The MS of each module is connected via two parallel short flexible cables to a connection box. From there the connection to the magnet in the ring is made via two parallel semi-rigid SF₆-filled transmission cables.

The MS and the DS are connected by a single low-attenuation SF₆ - filled cable (PFN) .

The four magnets of this system are supplied with high-voltage pulses (up to 40 kV) from their respective module.

3 . GENERAL PRINCIPLES TO BE OBSERVED FOR SAFE WORKING ON THE KFA 45 KICKER SYSTEM

Because of the large number of interconnections which exist between different , sometimes remote, parts of the system and the very high voltages which are present, certain principles must be laid down in order to guarantee safe working conditions during repair, modification or maintenance. The application of these rules may result in more equipment being isolated than is strictly necessary to have access to a particular system, but the principles must nevertheless be rigorously respected .

The principles are as follows :

3.1 No work may be performed on any equipment installed in the PS ring unless all pulse generators (1, 2, 3 and 4) and the oil system have been isolated.

3.2 No work may be performed on any pulse generator until it has been isolated from the three-phase electrical supply.

3.3 No work may be performed on the complete KFA 45 kicker system until isolation of the whole system has been carried out at the three-phase supply switchboard.

3.4 In the absence of complete isolation of the KFA 45 kicker system according to (3.3) above , individual electronic chassis, which are in some cases supplied with power from remote parts of the system, must be considered live until isolated by removing all of in-going and out- going cable connectors. Particular attention should be paid to the dual trigger pulse amplifier chassis and the fast dual trigger pulse amplifier in which there are voltages of up to three kV.

3.5 The system contains a certain number of electronically operated high- and low-voltage interlocks which are intended to prevent accidents involving personnel or damage to equipment in the event of faulty operation.

Under no circumstances are these interlocks to be relied upon to provide a safe environment for maintenance or repair work.

3.6 Work which involves dismantling of either the vacuum tanks, transmission cables, or PFN interfaces should not be started before any SF₆ gas in these interfaces has been reduced to atmospheric pressure.

4 . SAFE WORKING ON KFA 45 EQUIPMENT INSTALLED IN BUILDING 365

To work safely on any or all of the KFA 45 equipment installed in building 365 one should proceed as follows (note that the air conditioning system is not taken into account) :

4.1 The six Castell keys marked 451, 452, 453, 454, 455 and 456 should be removed from the keyboard and all of them personally placed in a special key box, which then allows the removal of a master key marked KFA 45. The removal of this key locks the five above-mentioned keys in the box and therefore ensures that the four modules and the oil system are isolated. The facility of isolating the electronics controls (key 456) in this manner is not available, so this key must be retained together with the master key .

4.2 A notice should be affixed to the switchboard giving the names of all the persons working on the equipment and specifying the one holding the keys. The keys must remain in the possession of one of the persons executing the work and must only be released ,

when the work is terminated, the equipment safe to re-energize, and obtained from (4.1) above automatically assumes responsibility for the safety of the personnel involved in the work on kicker modules in building 365.

5. SAFE WORKING ON THE KFA 45 EQUIPMENT INSTALLED IN THE PS RING

To work on any or all of the KFA 45 equipment installed in the ring, one should proceed as specified in Section 4. The holder of the keys automatically assumes responsibility for the safety of the personnel involved in the work in the PS ring. Any person working in the PS ring must be accompanied by a second person so that help is available in case of accident.

6. SIMULTANEOUS WORK ON THE KFA 45 EQUIPMENT IN THE PS RING AND IN BUILDING 365

Should it be necessary for several persons to work at the same time on equipment installed in the PS ring and in building 365, the following precautions must be taken :

- the procedure laid down in Section 5 must be carried out by the persons working on ring equipment. The holder of the keys must be one of the people working in the ring ;
- the holder of the keys becomes responsible for the safety of all the personnel working either in building 365 or in the PS ring .

7. SAFE WORKING WITH THE SYSTEM PARTLY DE-ENERGIZED

Under certain circumstances it may be necessary to carry out repair work on one or more generators with the other generators pulsing normally. In this case a risk of low- and high-voltage contact exists, and the work must be carried out by a qualified operator in the presence of a second person as defined in the CERN safety regulations.

In order to eliminate the risk of high-voltage contact and to minimize the risk of low-voltage contact, the following procedure must be strictly observed.

7.1 There is a risk of high-voltage pick-up from one magnet to the other, so the generator to be worked on has to be isolated from its magnet. To perform this, the responsible person should first isolate the generators to be worked on by removing the corresponding Castell keys at the three-phase supply switchboard. The keys must be personally retained until the modules are safe to re-energize .

7.2 It should be verified by inspection that the supply racks pertaining to the modules to be worked on are de-energized and that the capacitor banks in these racks are discharged.

7.3 Where work has to be done on a kicker module, all other modules should be temporarily stopped from pulsing by switching to " OFF " their " SORENSEN " power supplies, discharging their capacitor banks, and setting the " local HT switch " on the interlock unit to " OFF " .

7.4 The two blue flexible coaxial high-voltage cables connected to the output of the MS of the modules to be worked on should be located. These cables should be unplugged and they should be capped with the brass caps provided. Work on the modules thus de-energized may now proceed and the other modules concerned in (7.3) allowed to pulse.

7.5 If during repair work any parts normally at high voltage become exposed, these should be earthed with the earthing rod. After repair all earth connections must be removed before applying any power to the module .

8. SAFE WORKING ON THE OIL SYSTEM

Removal of Castell key 455 will completely isolate the main pump controls and maintenance control station. A person working on any part of the oil system must retain this key in his possession. The key must only be replaced in the switchboard when the work is terminated and the system safe to re-energize . When the 455 key is removed this will stop all kicker modules from working (electronic interlock).

Distribution :

Kicker Magnets Section
J.P. Riunaud

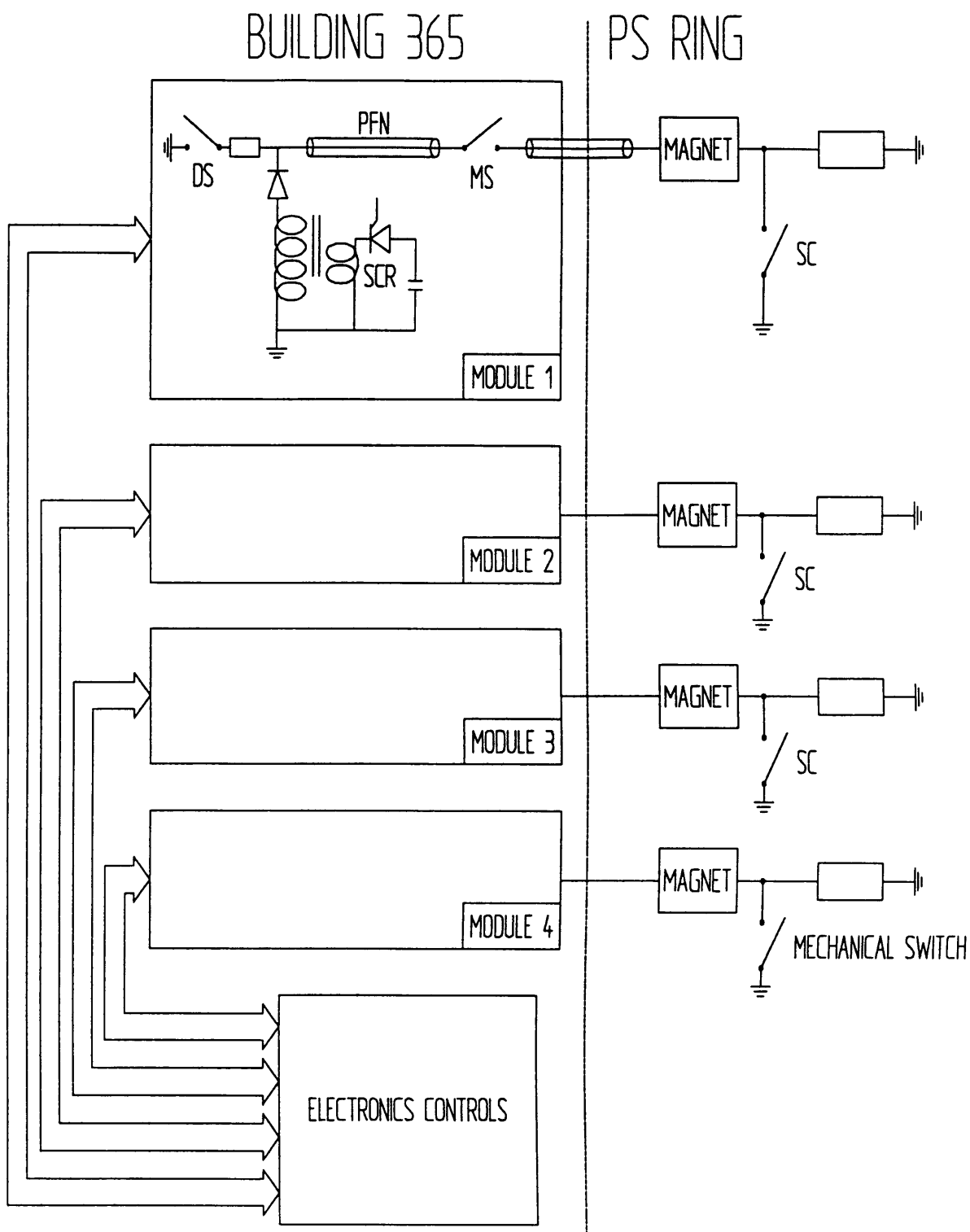

FIGURE 1 : KFA 45 BLOCK DIAGRAM

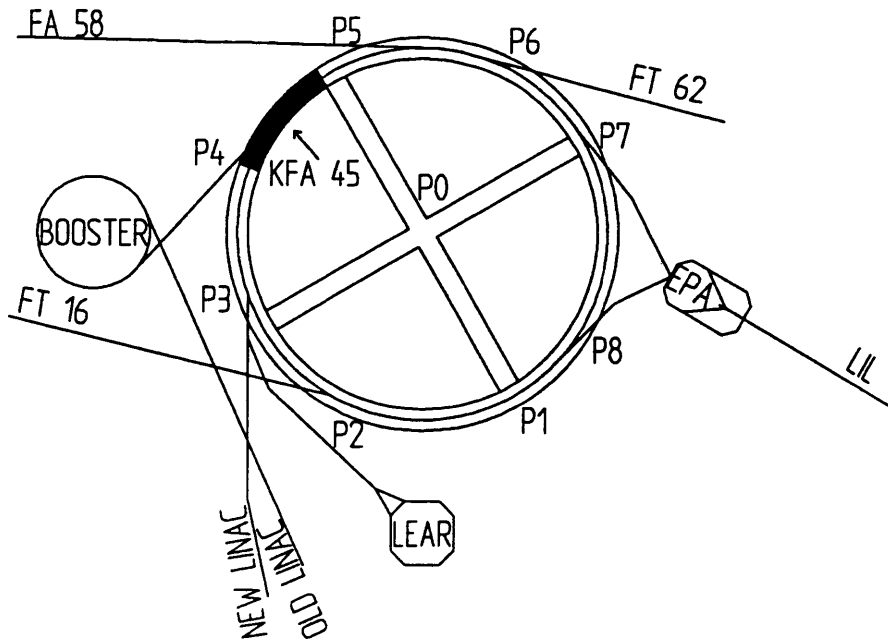

Figure 2a : Localization of the kickers in the PS ring

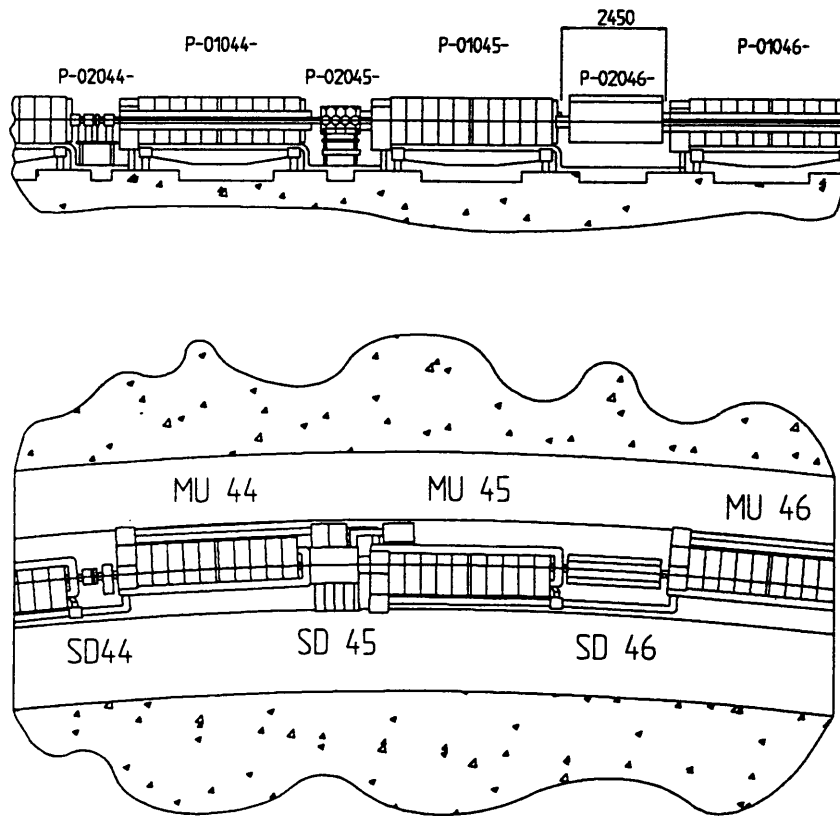

Figure 2 b : VIEWS OF THE KICKERS IN THE PS RING

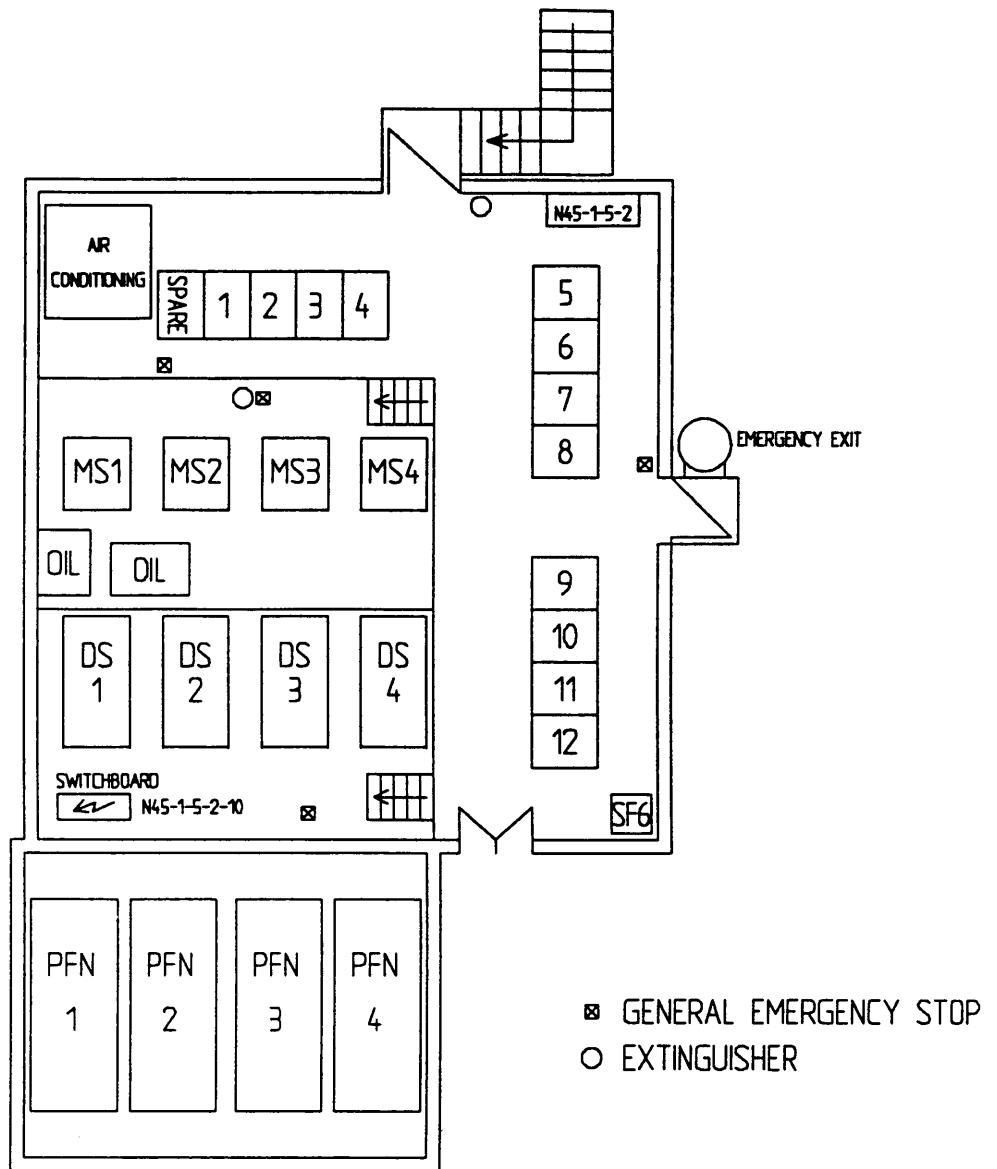

FIGURE 3 : KFA 45 EQUIPMENT IN BUILDING 365

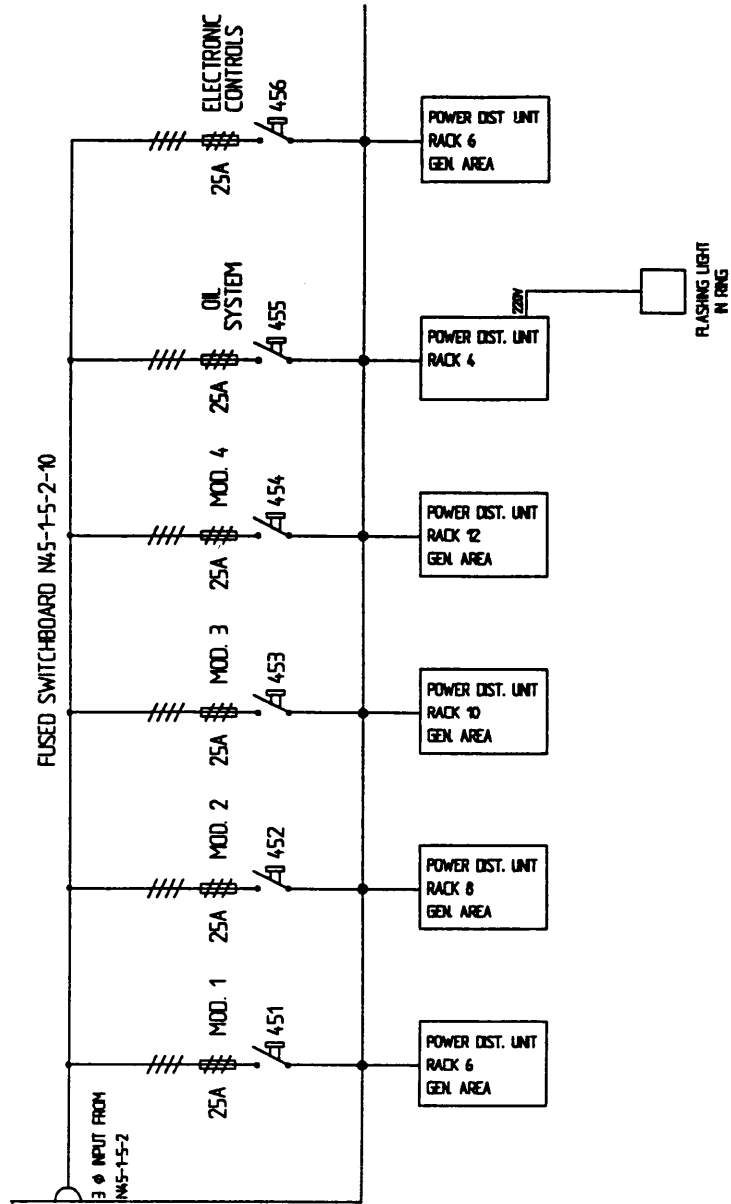

FIGURE 4 : KFA 45 POWER DISTRIBUTION