

Refno: PS/ML/Technical note/85-8

T E C H N I C A L   N O T E

25 July, 1985

Author(s): Mats Möller

Subject: The water-cooling system for the kicker electrode support in ACOL.

---

## 1. SCOPE

The kicker electrodes in the ACOL machine are supported by two 2.1 m long aluminium beams facing each other inside the vacuum tank. The electrode support beams can each be displaced by about 45 mm, so that they may follow the decrease in transverse dimension of the particle beam envelope. This displacement is achieved by means of two rigid shafts which support and position the beams, via linear guides and an actuator mounted outside the tank.

Resistors for the electrodes are mounted on the supporting beams. These have a thermal output of 500-800-1200 W per beam. In order to keep the electrode below a maximum temperature of +40 °C, a water-cooling system is needed. This document presents the dimensioning of this system.

## 2. SPECIFICATION

1. Thermal output of resistors: 500-800-1200 W
2. Temperature of input town-water: +15 °C
3. Pressure of input water: 3.5-4 bar
4. Max allowable temperature of beam: +40 °C

### 3. SYSTEM DESCRIPTION

In order to allow the displacement of the support beam, the system is equipped with flexible coils for cooling water supply. The water then passes via two tubes around the whole beam. In order to obtain good thermal contact between the tube and the beam, the tubes are pressed into a groove in the beam. In this groove is a film of indium placed, see Figure 1. The beam is then heated to +80 °C and the indium melts and forms a good contact medium.

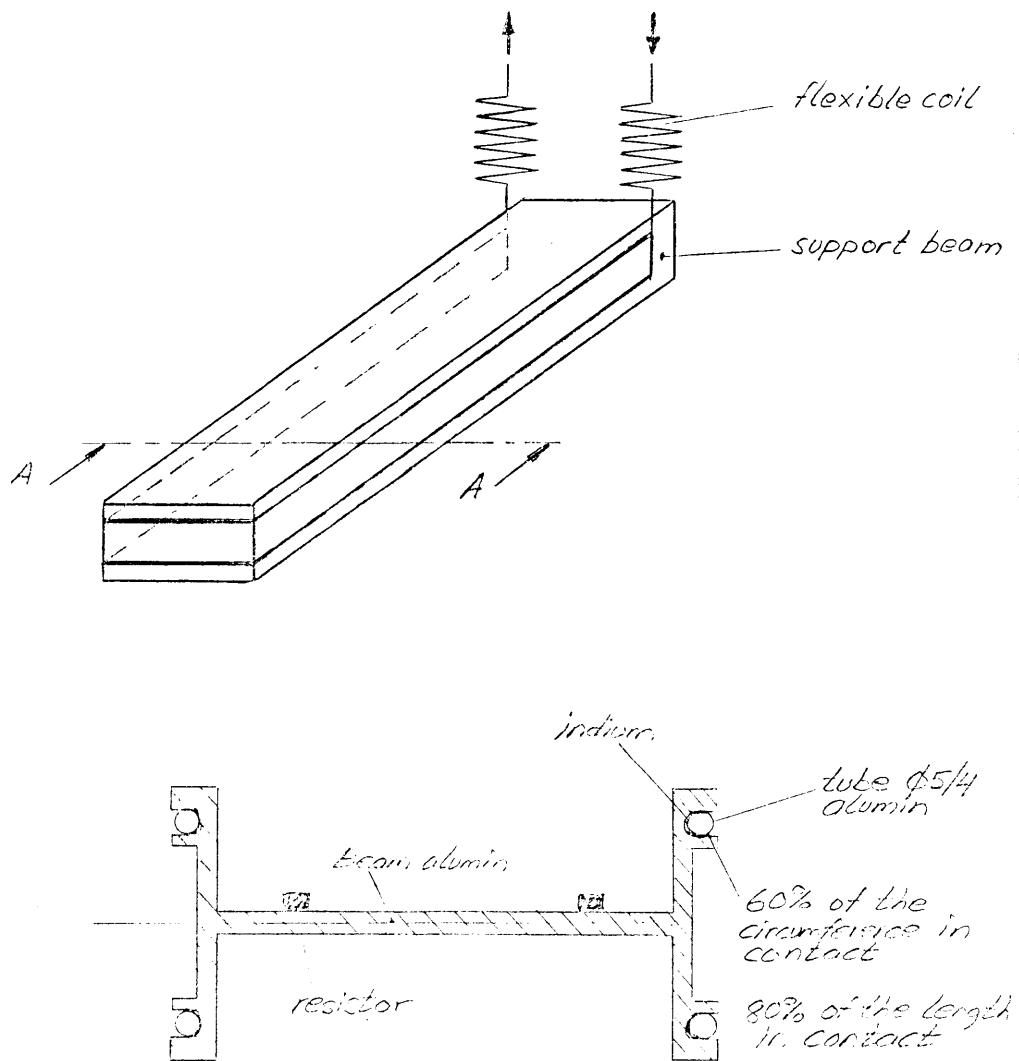

Figure 1: Support beam with cooling system

#### 4. CALCULATIONS

The temperature of the support beam and the pressure drop in the system are calculated for various values of flow and various internal diameters of the tube.

The physical constants used and material datas are as follows:

Town-water

|                      |   |
|----------------------|---|
| input temperature:   | 15 °C                                     |
| density:             | 998 kg/m <sup>3</sup>                     |
| kinematic viscosity: | 1.0843*10 <sup>-6</sup> m <sup>2</sup> /s |
| heat capacity:       | 4.18*10 <sup>+3</sup> W/(s·kg·K)          |
| Prandtl number:      | 7.9                                       |

Aluminium

|                       |             |
|-----------------------|-------------|
| thermal conductivity: | 209 W/(m·K) |
|-----------------------|-------------|

Indium

|                       |            |
|-----------------------|------------|
| thermal conductivity: | 24 W/(m·K) |
|-----------------------|------------|

The following six cases have been studied :

Table 1: Calculation cases

| Case | Input effect | Diameter of coiled tube | Diameter of long tube |
|------|--------------|-------------------------|-----------------------|
| 1    | 1200 W       | 5 mm                    | 4 mm                  |
| 2    | 800 W        | 5 mm                    | 4 mm                  |
| 3    | 500 W        | 5 mm                    | 4 mm                  |
| 4    | 1200 W       | 3 mm                    | 4 mm                  |
| 5    | 800 W        | 3 mm                    | 4 mm                  |
| 6    | 500 W        | 3 mm                    | 4 mm                  |

Page 5-10 shows the printout of the results for the six cases.

The theory and formulas used in the calculations, together with the listing of the FORTRAN program, are added in Appendix A.

If the water-cooling system fails to work:

$$Q = c_p \cdot m \cdot \Delta T$$

$$\Delta T = Q / (c_p \cdot m)$$

$$Q = 1200 \text{ W}$$

$$m = 25 \text{ kg}$$

$$c_p = 921 \text{ Ws}/(\text{kg}\cdot\text{K})$$

$$\Delta T = 0.0521 \text{ }^\circ\text{C}/\text{s} = 3.1 \text{ }^\circ\text{C}/\text{min}$$

The temperature in the beam will raise with 3.1  $^\circ\text{C}/\text{min}$ .

CASE NO : 1  
-----

HEAT CALCULATION  
-----

Input effect Q=1200. W  
Input water temp TI= 15. oC  
Coiled tube inner diam DS=0.005 m  
length LS=3.960 m  
coil diam R =0.035 m  
Long tube inner diam DL=0.004 m  
length LL=4.100 m

Water density RO= 998. Kg/m3  
NV=0.1084E-05  
PR=7.900  
CP=0.4180E+04

Starting value flow FS= 1.0 l/min  
Contact area tube/beam CONT= 0.309E-01 m2 (per tube)

|                             |       |       |       |       |       |       |        |        |        |        |        |        |        |
|-----------------------------|-------|-------|-------|-------|-------|-------|--------|--------|--------|--------|--------|--------|--------|
| Flow (l/min) :              | 1.0   | 1.3   | 1.6   | 1.9   | 2.2   | 2.5   | 2.8    | 3.1    | 3.4    | 3.7    | 4.0    | 4.3    | 4.6    |
| Output water temp (oC) :    | 32.3  | 28.3  | 25.8  | 24.1  | 22.8  | 21.9  | 21.2   | 20.6   | 20.1   | 19.7   | 19.3   | 19.0   | 18.8   |
| Max temp in beam (oC) :     | 57.7  | 52.7  | 49.6  | 47.4  | 45.8  | 44.6  | 43.6   | 42.8   | 42.2   | 41.6   | 41.2   | 40.8   | 40.4   |
| Coiled tube                 |       |       |       |       |       |       |        |        |        |        |        |        |        |
| Water speed (m/s) :         | 0.8   | 1.1   | 1.4   | 1.6   | 1.9   | 2.1   | 2.4    | 2.6    | 2.9    | 3.1    | 3.4    | 3.6    | 3.9    |
| Reynolds number :           | 3914. | 5088. | 6263. | 7437. | 8611. | 9785. | 10960. | 12134. | 13308. | 14482. | 15657. | 16831. | 18005. |
| Pressure drop (bar) :       | 0.2   | 0.2   | 0.3   | 0.5   | 0.6   | 0.8   | 0.9    | 1.1    | 1.3    | 1.5    | 1.7    | 2.0    | 2.2    |
| Long tube                   |       |       |       |       |       |       |        |        |        |        |        |        |        |
| Water speed (m/s) :         | 0.7   | 0.9   | 1.1   | 1.3   | 1.5   | 1.7   | 1.9    | 2.1    | 2.3    | 2.5    | 2.7    | 2.9    | 3.1    |
| Reynolds number :           | 2446. | 3180. | 3914. | 4648. | 5382. | 6116. | 6850.  | 7584.  | 8318.  | 9052.  | 9785.  | 10519. | 11253. |
| Pressure drop (bar) :       | 0.1   | 0.2   | 0.3   | 0.3   | 0.4   | 0.6   | 0.7    | 0.8    | 1.0    | 1.1    | 1.3    | 1.5    | 1.7    |
| Total pressure drop (bar) : | 0.4   | 0.6   | 0.8   | 1.1   | 1.4   | 1.8   | 2.2    | 2.6    | 3.1    | 3.6    | 4.1    | 4.7    | 5.3    |

CASE NO : 2  
-----

HEAT CALCULATION  
-----

Input effect Q= 800. W  
 Input water temp TI= 15. oC  
 Coiled tube inner diam DS=0.005 m  
 length LS=3.960 m  
 coil diam R =0.035 m  
 Long tube inner diam DL=0.004 m  
 length LL=4.100 m

Water density RO= 998. Kg/m3  
 NV=0.1084E-05  
 PR=7.900  
 CP=0.4180E+04

Starting value flow FS= 1.0 l/min  
 Contact area tube/beam CONT= 0.309E-01 m2 (per tube)

|                          |      |      |      |      |      |      |      |      |      |      |      |      |      |
|--------------------------|------|------|------|------|------|------|------|------|------|------|------|------|------|
| Flow (l/min) :           | 1.0  | 1.3  | 1.6  | 1.9  | 2.2  | 2.5  | 2.8  | 3.1  | 3.4  | 3.7  | 4.0  | 4.3  | 4.6  |
| Output water temp (oC) : | 26.5 | 23.9 | 22.2 | 21.1 | 20.2 | 19.6 | 19.1 | 18.7 | 18.4 | 18.1 | 17.9 | 17.7 | 17.5 |
| Max temp in beam (oC) :  | 43.5 | 40.2 | 38.1 | 36.6 | 35.5 | 34.7 | 34.1 | 33.6 | 33.1 | 32.8 | 32.5 | 32.2 | 32.0 |

Coiled tube

|                       |       |       |       |       |       |       |        |        |        |        |        |        |        |
|-----------------------|-------|-------|-------|-------|-------|-------|--------|--------|--------|--------|--------|--------|--------|
| Water speed (m/s) :   | 0.8   | 1.1   | 1.4   | 1.6   | 1.9   | 2.1   | 2.4    | 2.6    | 2.9    | 3.1    | 3.4    | 3.6    | 3.9    |
| Reynolds number :     | 3914. | 5088. | 6263. | 7437. | 8611. | 9785. | 10960. | 12134. | 13308. | 14482. | 15657. | 16831. | 18005. |
| Pressure drop (bar) : | 0.2   | 0.2   | 0.3   | 0.5   | 0.6   | 0.8   | 0.9    | 1.1    | 1.3    | 1.5    | 1.7    | 2.0    | 2.2    |

Long tube

|                       |       |       |       |       |       |       |       |       |       |       |       |        |        |
|-----------------------|-------|-------|-------|-------|-------|-------|-------|-------|-------|-------|-------|--------|--------|
| Water speed (m/s) :   | 0.7   | 0.9   | 1.1   | 1.3   | 1.5   | 1.7   | 1.9   | 2.1   | 2.3   | 2.5   | 2.7   | 2.9    | 3.1    |
| Reynolds number :     | 2446. | 3180. | 3914. | 4648. | 5382. | 6116. | 6850. | 7584. | 8318. | 9052. | 9785. | 10519. | 11253. |
| Pressure drop (bar) : | 0.1   | 0.2   | 0.3   | 0.3   | 0.4   | 0.6   | 0.7   | 0.8   | 1.0   | 1.1   | 1.3   | 1.5    | 1.7    |

|                             |     |     |     |     |     |     |     |     |     |     |     |     |     |
|-----------------------------|-----|-----|-----|-----|-----|-----|-----|-----|-----|-----|-----|-----|-----|
| Total pressure drop (bar) : | 0.4 | 0.6 | 0.8 | 1.1 | 1.4 | 1.8 | 2.2 | 2.6 | 3.1 | 3.6 | 4.1 | 4.7 | 5.3 |
|-----------------------------|-----|-----|-----|-----|-----|-----|-----|-----|-----|-----|-----|-----|-----|

CASE NO : 3  
-----

HEAT CALCULATION  
-----

Input effect Q= 500. W  
 Input water temp TI= 15. oC  
 Coiled tube inner diam DS=0.005 m  
 length LS=3.960 m  
 coil diam R =0.035 m  
 Long tube inner diam DL=0.004 m  
 length LL=4.100 m

water density RO= 998. Kg/m3  
 NV=0.1084E-05  
 PR=7.900  
 CP=0.4180E+04

Starting value flow FS= 1.0 l/min  
 Contact area tube/beam CONT= 0.309E-01 m2 (per tube)

|                          |      |      |      |      |      |      |      |      |      |      |      |      |      |
|--------------------------|------|------|------|------|------|------|------|------|------|------|------|------|------|
| Flow (l/min) :           | 1.0  | 1.3  | 1.6  | 1.9  | 2.2  | 2.5  | 2.8  | 3.1  | 3.4  | 3.7  | 4.0  | 4.3  | 4.6  |
| Output water temp (oC) : | 22.2 | 20.5 | 19.5 | 18.8 | 18.3 | 17.9 | 17.6 | 17.3 | 17.1 | 16.9 | 16.8 | 16.7 | 16.6 |
| Max temp in beam (oC) :  | 32.8 | 30.7 | 29.4 | 28.5 | 27.8 | 27.3 | 26.9 | 26.6 | 26.3 | 26.1 | 25.9 | 25.7 | 25.6 |

Coiled tube

|                       |       |       |       |       |       |       |        |        |        |        |        |        |        |
|-----------------------|-------|-------|-------|-------|-------|-------|--------|--------|--------|--------|--------|--------|--------|
| Water speed (m/s) :   | 0.8   | 1.1   | 1.4   | 1.6   | 1.9   | 2.1   | 2.4    | 2.6    | 2.9    | 3.1    | 3.4    | 3.6    | 3.9    |
| Reynolds number :     | 3914. | 5088. | 6263. | 7437. | 8611. | 9785. | 10960. | 12134. | 13308. | 14482. | 15657. | 16831. | 18005. |
| Pressure drop (bar) : | 0.2   | 0.2   | 0.3   | 0.5   | 0.6   | 0.8   | 0.9    | 1.1    | 1.3    | 1.5    | 1.7    | 2.0    | 2.2    |

Long tube

|                             |       |       |       |       |       |       |       |       |       |       |       |        |        |
|-----------------------------|-------|-------|-------|-------|-------|-------|-------|-------|-------|-------|-------|--------|--------|
| Water speed (m/s) :         | 0.7   | 0.9   | 1.1   | 1.3   | 1.5   | 1.7   | 1.9   | 2.1   | 2.3   | 2.5   | 2.7   | 2.9    | 3.1    |
| Reynolds number :           | 2446. | 3180. | 3914. | 4648. | 5382. | 6116. | 6850. | 7584. | 8318. | 9052. | 9785. | 10519. | 11253. |
| Pressure drop (bar) :       | 0.1   | 0.2   | 0.3   | 0.3   | 0.4   | 0.6   | 0.7   | 0.8   | 1.0   | 1.1   | 1.3   | 1.5    | 1.7    |
| Total pressure drop (bar) : | 0.4   | 0.6   | 0.8   | 1.1   | 1.4   | 1.8   | 2.2   | 2.6   | 3.1   | 3.6   | 4.1   | 4.7    | 5.3    |

CASE NO : 4  
-----

HEAT CALCULATION  
-----

Input effect Q=1200. W  
 Input water temp TI= 15. oC  
 Coiled tube inner diam DS=0.003 m  
 length LS=3.960 m  
 coil diam R =0.030 m  
 Long tube inner diam DL=0.004 m  
 length LL=4.100 m  
 water density

RO= 998. Kg/m3  
 NV=0.1084E-05  
 PR=7.900  
 CP=0.4180E+04

Starting value flow FS= 1.0 l/min

Contact area tube/beam CONT= 0.309E-01 m2 (per tube)

|                          |      |      |      |      |      |      |      |      |      |      |      |      |      |
|--------------------------|------|------|------|------|------|------|------|------|------|------|------|------|------|
| Flow (l/min) :           | 1.0  | 1.3  | 1.6  | 1.9  | 2.2  | 2.5  | 2.8  | 3.1  | 3.4  | 3.7  | 4.0  | 4.3  | 4.6  |
| Output water temp (oC) : | 32.3 | 28.3 | 25.8 | 24.1 | 22.8 | 21.9 | 21.2 | 20.6 | 20.1 | 19.7 | 19.3 | 19.0 | 18.8 |
| Max temp in beam (oC) :  | 57.7 | 52.7 | 49.6 | 47.4 | 45.8 | 44.6 | 43.6 | 42.8 | 42.2 | 41.6 | 41.2 | 40.8 | 40.4 |

Coiled tube

|                       |       |       |        |        |        |        |        |        |        |        |        |        |        |
|-----------------------|-------|-------|--------|--------|--------|--------|--------|--------|--------|--------|--------|--------|--------|
| Water speed (m/s) :   | 2.4   | 3.1   | 3.8    | 4.5    | 5.2    | 5.9    | 6.6    | 7.3    | 8.0    | 8.7    | 9.4    | 10.1   | 10.8   |
| Reynolds number :     | 6524. | 8481. | 10438. | 12395. | 14352. | 16309. | 18266. | 20223. | 22180. | 24137. | 26094. | 28051. | 30009. |
| Pressure drop (bar) : | 1.6   | 2.5   | 3.6    | 4.9    | 6.3    | 7.9    | 9.6    | 11.5   | 13.5   | 15.7   | 18.0   | 20.5   | 23.1   |

Long tube

|                       |       |       |       |       |       |       |       |       |       |       |       |        |        |
|-----------------------|-------|-------|-------|-------|-------|-------|-------|-------|-------|-------|-------|--------|--------|
| Water speed (m/s) :   | 0.7   | 0.9   | 1.1   | 1.3   | 1.5   | 1.7   | 1.9   | 2.1   | 2.3   | 2.5   | 2.7   | 2.9    | 3.1    |
| Reynolds number :     | 2446. | 3180. | 3914. | 4648. | 5382. | 6116. | 6850. | 7584. | 8318. | 9052. | 9785. | 10519. | 11253. |
| Pressure drop (bar) : | 0.1   | 0.2   | 0.3   | 0.3   | 0.4   | 0.6   | 0.7   | 0.8   | 1.0   | 1.1   | 1.3   | 1.5    | 1.7    |

|                            |     |     |     |     |      |      |      |      |      |      |      |      |      |
|----------------------------|-----|-----|-----|-----|------|------|------|------|------|------|------|------|------|
| Total pressure drop (bar): | 3.2 | 5.1 | 7.3 | 9.9 | 12.8 | 16.1 | 19.6 | 23.4 | 27.6 | 32.0 | 36.7 | 41.7 | 47.0 |
|----------------------------|-----|-----|-----|-----|------|------|------|------|------|------|------|------|------|



CASE NO : 5  
-----

HEAT CALCULATION  
-----

Input effect Q= 800. W  
 Input water temp TI= 15. oC  
 Coiled tube  
   inner diam DS=0.003 m  
   length LS=3.960 m  
   coil diam R =0.030 m  
 Long tube  
   inner diam DL=0.004 m  
   length LL=4.100 m

Water density RO= 998. Kg/m3  
 NY=0.1084E-05  
 PR=7.900  
 CP=0.4180E+04

Starting value flow FS= 1.0 l/min  
 Contact area tube/beam CONT= 0.309E-01 m2 (per tube)

|                            |       |       |        |        |        |        |        |        |        |        |        |        |        |
|----------------------------|-------|-------|--------|--------|--------|--------|--------|--------|--------|--------|--------|--------|--------|
| Flow (l/min) :             | 1.0   | 1.3   | 1.6    | 1.9    | 2.2    | 2.5    | 2.8    | 3.1    | 3.4    | 3.7    | 4.0    | 4.3    | 4.6    |
| Output water temp (oC) :   | 26.5  | 23.9  | 22.2   | 21.1   | 20.2   | 19.6   | 19.1   | 18.7   | 18.4   | 18.1   | 17.9   | 17.7   | 17.5   |
| Max temp in beam (oC) :    | 43.5  | 40.2  | 38.1   | 36.6   | 35.5   | 34.7   | 34.1   | 33.6   | 33.1   | 32.8   | 32.5   | 32.2   | 32.0   |
| Coiled tube                |       |       |        |        |        |        |        |        |        |        |        |        |        |
| Water speed (m/s) :        | 2.4   | 3.1   | 3.8    | 4.5    | 5.2    | 5.9    | 6.6    | 7.3    | 8.0    | 8.7    | 9.4    | 10.1   | 10.8   |
| Reynolds number :          | 6524. | 8481. | 10438. | 12395. | 14352. | 16309. | 18266. | 20223. | 22180. | 24137. | 26094. | 28051. | 30009. |
| Pressure drop (bar) :      | 1.6   | 2.5   | 3.6    | 4.9    | 6.3    | 7.9    | 9.6    | 11.5   | 13.5   | 15.7   | 18.0   | 20.5   | 23.1   |
| Long tube                  |       |       |        |        |        |        |        |        |        |        |        |        |        |
| Water speed (m/s) :        | 0.7   | 0.9   | 1.1    | 1.3    | 1.5    | 1.7    | 1.9    | 2.1    | 2.3    | 2.5    | 2.7    | 2.9    | 3.1    |
| Reynolds number :          | 2446. | 3180. | 3914.  | 4648.  | 5382.  | 6116.  | 6850.  | 7584.  | 8318.  | 9052.  | 9785.  | 10519. | 11253. |
| Pressure drop (bar) :      | 0.1   | 0.2   | 0.3    | 0.3    | 0.4    | 0.6    | 0.7    | 0.8    | 1.0    | 1.1    | 1.3    | 1.5    | 1.7    |
| Total pressure drop (bar): | 3.2   | 5.1   | 7.3    | 9.9    | 12.8   | 16.1   | 19.6   | 23.4   | 27.6   | 32.0   | 36.7   | 41.7   | 47.0   |

CASE NO : 6  
-----

HEAT CALCULATION  
-----

Input effect Q= 500. W  
 Input water temp TI= 15. oC  
 Coiled tube inner diam DS=0.003 m  
 length LS=3.960 m  
 coil diam R =0.030 m  
 Long tube inner diam DL=0.004 m  
 length LL=4.100 m

Water density RO= 998. Kg/m3  
 NY=0.1084E-05  
 PR=7.900  
 CP=0.4180E+04

Starting value flow FS= 1.0 l/min  
 Contact area tube/beam CONT= 0.309E-01 m2 (per tube)

|                          |      |      |      |      |      |      |      |      |      |      |      |      |      |
|--------------------------|------|------|------|------|------|------|------|------|------|------|------|------|------|
| Flow (l/min) :           | 1.0  | 1.3  | 1.6  | 1.9  | 2.2  | 2.5  | 2.8  | 3.1  | 3.4  | 3.7  | 4.0  | 4.3  | 4.6  |
| Output water temp (oC) : | 22.2 | 20.5 | 19.5 | 18.8 | 18.3 | 17.9 | 17.6 | 17.3 | 17.1 | 16.9 | 16.8 | 16.7 | 16.6 |
| Max temp in beam (oC) :  | 32.8 | 30.7 | 29.4 | 28.5 | 27.8 | 27.3 | 26.9 | 26.6 | 26.3 | 26.1 | 25.9 | 25.7 | 25.6 |

Coiled tube

|                       |       |       |        |        |        |        |        |        |        |        |        |        |        |
|-----------------------|-------|-------|--------|--------|--------|--------|--------|--------|--------|--------|--------|--------|--------|
| Water speed (m/s) :   | 2.4   | 3.1   | 3.8    | 4.5    | 5.2    | 5.9    | 6.6    | 7.3    | 8.0    | 8.7    | 9.4    | 10.1   | 10.8   |
| Reynolds number :     | 6524. | 8481. | 10438. | 12395. | 14352. | 16309. | 18266. | 20223. | 22180. | 24137. | 26094. | 28051. | 30009. |
| Pressure drop (bar) : | 1.6   | 2.5   | 3.6    | 4.9    | 6.3    | 7.9    | 9.6    | 11.5   | 13.5   | 15.7   | 18.0   | 20.5   | 23.1   |

Long tube

|                       |       |       |       |       |       |       |       |       |       |       |       |        |        |
|-----------------------|-------|-------|-------|-------|-------|-------|-------|-------|-------|-------|-------|--------|--------|
| Water speed (m/s) :   | 0.7   | 0.9   | 1.1   | 1.3   | 1.5   | 1.7   | 1.9   | 2.1   | 2.3   | 2.5   | 2.7   | 2.9    | 3.1    |
| Reynolds number :     | 2446. | 3180. | 3914. | 4648. | 5382. | 6116. | 6850. | 7584. | 8318. | 9052. | 9785. | 10519. | 11253. |
| Pressure drop (bar) : | 0.1   | 0.2   | 0.3   | 0.3   | 0.4   | 0.6   | 0.7   | 0.8   | 1.0   | 1.1   | 1.3   | 1.5    | 1.7    |

|                            |     |     |     |     |      |      |      |      |      |      |      |      |      |
|----------------------------|-----|-----|-----|-----|------|------|------|------|------|------|------|------|------|
| Total pressure drop (bar): | 3.2 | 5.1 | 7.3 | 9.9 | 12.8 | 16.1 | 19.6 | 23.4 | 27.6 | 32.0 | 36.7 | 41.7 | 47.0 |
|----------------------------|-----|-----|-----|-----|------|------|------|------|------|------|------|------|------|

## 5. CONCLUSIONS

The calculation shows that it is impossible to use a coiled tube with an internal diameter of 3 mm, due to the very high pressure drop for small values of the flow (case 4-6).

With the larger tube we can keep the max-temperature at around 42 °C with a flow of 3.4 l/min for case 1. The corresponding pressure drop in the system is then 3.1 bar. This temperature is achieved just near the the resistors. At the edge of the beam is the temperature much lower , see Figure 2.

For case 2 and 3, can we see that the temperatures can be kept well below 40 °C, for flows in the region of 2-3 l/min.

If the water-cooling is stopped for some reason , the beam will raise in temperature with 3.1 °C per minute. This means that the melting temperature for indium will be reached after about 20 minutes. It is therefore necessary to have a thermostat on the beam. This thermostat can then give a warning or brake the system when the temperature has reached 50-60 °C.

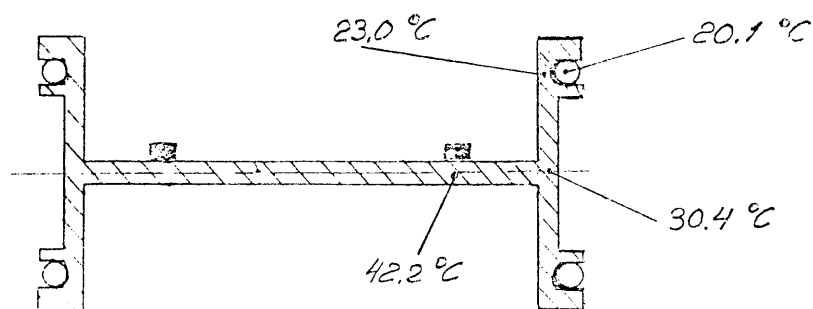

Figure 2: Temperatures in the beam for case 1

## 6. DISCUSSION

Lime-sedimentation in the cooling tubes can after some time have negative influence on the thermal conductivity and on the pressure drops in the tubes. A survey of available data indicates that real problems of this kind occur when the water is heated or evaporated ( [1] ). In the case under consideration the water is kept at a very low temperature (  $<20\text{ }^{\circ}\text{C}$  ) and we do not have any evaporation so the sedimentation is a slow process. It can not be neglected though, a visual inspection of the tubes must be carried out every second year. We can also compare the recommended limit values for water used in cooling towers ( [2] page 693) with the town-water here at CERN ( [3] ).

The values of the water-hardness in [3] are given in  $^{\circ}\text{F}$ , a transformation to  $\text{mol}/\text{m}^3$  is made ( [2] page 620):

$$1\text{ }^{\circ}\text{F} = 10\text{ mg CaCO}_3/\text{kg}$$

$\text{CaCO}_3$  has a molar mass of  $100.09\text{ g/mol}$ , density of water  $998\text{ kg}/\text{m}^3$

$$1\text{ }^{\circ}\text{F} = 10 \cdot 10^{-3} \cdot 998 / (100.09) = 0.0997\text{ mol}/\text{m}^3$$

Table 2: Limit values for water

|                    | Recommended limit values at $T=60\text{ }^{\circ}\text{C}$ | Actual values at CERN        |
|--------------------|--|------------------------------|
| pH-value           | 7-8.5  | 7.58                         |
| Total hardness     | $<10.7\text{ mol}/\text{m}^3$                              | $3.43\text{ mol}/\text{m}^3$ |
| Temporary hardness | $<6.4\text{ mol}/\text{m}^3$                               | $2.68\text{ mol}/\text{m}^3$ |
| Salt               | $<2500\text{ mg/l}$  | $354\text{ mg/l}$            |
| Fe                 | $<0.3\text{ mg/l}$   | $0.003\text{ mg/l}$          |
| Mn                 | $<0.1\text{ mg/l}$   | $0.084\text{ mg/l}$          |
| Cl                 | $<284\text{ mg/l}$   | $15.6\text{ mg/l}$           |
| $\text{SO}_4$      | $<288\text{ mg/l}$   | $49.1\text{ mg/l}$           |

## 7. EXPERIMENTAL TEST

In order to verify the analyses, a measurement of the pressure drops in the coiled tubes has been performed. The test-configuration is shown in Fig 3.

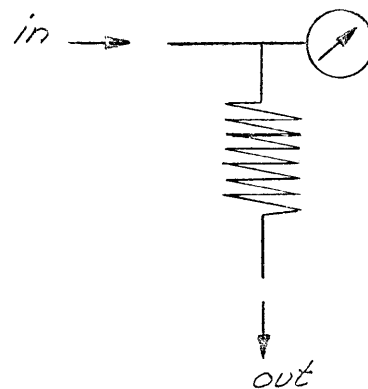

Figure 3: Test configuration

The pressure drop as function of flow has been plotted in Fig 4. We can see that the discrepancies between calculated and measured values are very low. About 0.1 bar for the tube with I.D.= 5 mm and 0.2 bar for the tube with I.D.= 3 mm.

This result must be regarded as very satisfactory, and it shows that the calculations are reliable.

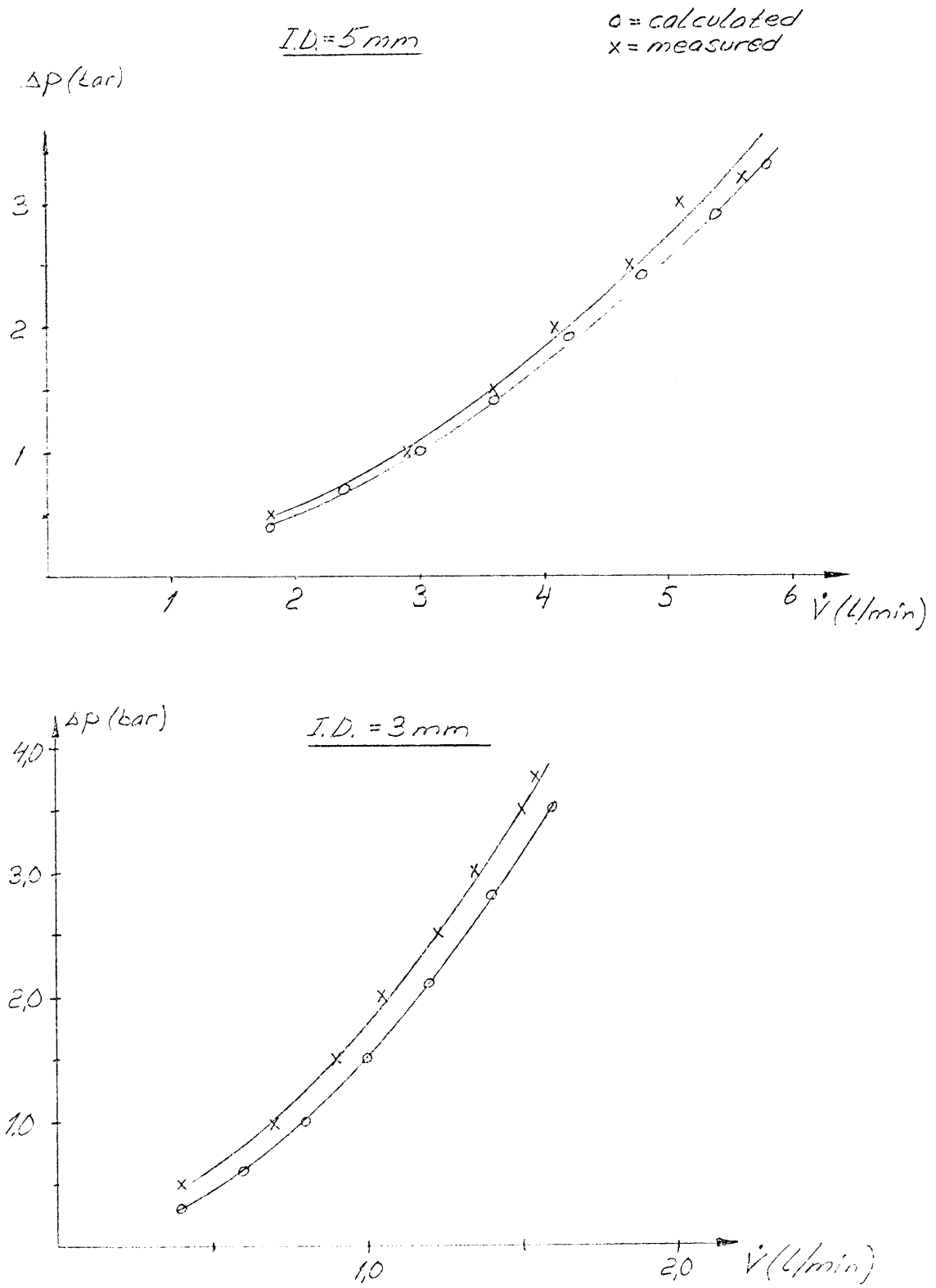

Figure 4: Pressure drop in coiled tube

#### REFERENCES

- [1] "MARK" Standard handbook for mechanical engineers.
- [2] Dubbel, Taschenbuch für den Maschinenbau, 15. Auflage
- [3] Water analysis made by Services Industriels de Geneve in May 1984.

APPENDIX A

THEORY USED FOR THE CALCULATIONS



## 1. HEAT TRANSFER

Steady heat conduction through a plane wall:

$$\dot{Q} = \lambda \cdot A \cdot (T_1 - T_2)$$

Steady heat conduction through a cylindrical wall:

$$\dot{Q} = 2\pi \cdot l \cdot \lambda \cdot (T_1 - T_2) / \ln(T_2/T_1)$$

Convection and heat transfer:

$$\dot{Q} = \alpha \cdot A \cdot (T_1 - T_2)$$

$$\text{Nussels number } Nu = \alpha \cdot l / \lambda$$

$$\text{Reynolds number } Re = w \cdot d / \nu$$

Turbulent flow in circular pipe:

$$Nu = 0.032 \cdot Re^{0.8} \cdot Pr^{0.37} \cdot (d/l)^{0.054}$$

## 2. STEADY TURBULENT FLOW IN PIPES

Turbulent if:

$$Re > 2320$$

The pressure drop:

$$\Delta p = (\lambda \cdot l / d) \cdot \rho \cdot v^2 / 2 + \Sigma \zeta \cdot \rho \cdot v^2 / 2$$

$$\lambda = 0.3164 / \sqrt[4]{Re}$$

```

PROGRAM PRESS
C
C PROGRAM FOR CALCULATION OF TEMPERATURES AND
C PRESSURE DROPS IN WATER COOLING SYSTEMS
C
C WRITTEN 1/5 1985 MATS MOLLER
C
C DIMENSION SOUT(10,20),CON(4)
C REAL NY,LS,KSIS,LL,KSIL,LAMS,LAML,QIN,PI,LA
C THERMAL CONDUCTIVITY TUBE,HOLDER,BEAM
C DATA CON/209.,209.,209.,24./
C STARTING VALUE FLOW : FS
C INPUT WATER TEMP: TIN
C INPUT EFFECT: QIN
C CASE NUMBER: ICAS
C READ (*,*)FS,TIN,QIN,ICAS
C NY FOR WATER: NY
C DENSITY FOR WATER: RO
C PRANDTL NUMBER FOR WATER: PR
C HEAT CAPACITY FOR WATER: CP
C LAMBDA FOR WATER: LA
C READ (*,*) NY,RO,PR,CP,LA
C COILED TUBE, LENGTH: LS
C INTERNAL DIAM: DS
C COIL DIAMETER: R
C KSI: KSIS
C READ (*,*) LS,DS,R,KSIS
C LONG TUBE, LENGTH: LL
C INTERNAL DIAMETER: DL
C KSI: KSIL
C CONTACT AREA TUBE/BEAM (M2): CONT ( PER TUBE )
C READ (*,*) LL,DL,KSIL,CONT
C PI=4*ATAN(1.)
C I=0
C WRITE(*,900) ICAS
900 FORMAT('1'/'0',65X,'CASE NO : ',I2,
&        /' ',65X,12('-'))
C WRITE(*,1000) QIN,TIN,DS,LS,R,DL,LL,RO,NY,PR,CP,FS,CONT
1000 FORMAT( '0',15X,'HEAT CALCULATION',
&        /' ',15X,16('-'),
&        /'0',15X,'Input effect      Q=' ,F5.0,' W',
&        /' ',15X,'Input water temp  TI=' ,F4.0,' oC',
&        /' ',15X,'Coiled tube ',
&        /' ',15X,'      inner diam    DS=' ,F5.3,' m',
&        /' ',15X,'      length        LS=' ,F5.3,' m',
&        /' ',15X,'      coil diam     R = ' ,F5.3,' m',
&        /' ',15X,'Long tube ',
&        /' ',15X,'      inner diam    DL=' ,F5.3,' m',
&        /' ',15X,'      length        LL=' ,F5.3,' m',
&        /' ',15X,'Water',
&        /' ',15X,'      density      RO=' ,F5.0,' Kg/m3',
&        /' ',15X,'      NY=' ,E10.4,
&        /' ',15X,'      PR=' ,F5.3,
&        /' ',15X,'      CP=' ,E10.4,
&        /' ',15X,'Starting value flow    FS=' ,F4.1,' 1/min',
&        /' ',15X,'Contact area tube/beam CONT=' ,E10.3,' m2',
&        /' ',15X,'      (per tube)')
C AS=PI*DS*DS/4

```

```

AL=PI*DL*DL/4
10 VS=FS/(1000*60*AS)
VL=VS*AS/(2*AL)
RES = VS*DS/NY
REL = VL*DL/NY
LAMS = 0.3164/(RES**0.25)
LAML = 0.3164/(REL**0.25)
C PRESSURE DROP IN COILED TUBE
PS=RO*VS*VS/2*((LAMS*LS/DS)*(1+1.87*DS/R)+KSYS)*1.E-5
C PRESSURE DROP IN LONG TUBE
PL=RO*VL*VL/2*(LAML*LL/DL+KSIL)*1.E-5
C TOTAL DROP
PT=2*PS+PL/2
C CALCULATE THE TEMPERATURES
DT=QIN/(CP*AS*VS*RO)
TOUT=TIN+DT
ALF=0.032*(REL**0.8)*(PR**0.37)*((DL/LL)**0.054)*LA/DL
TL=(QIN/2)/(ALF*CONT)
TB=(QIN/2)*LOG((DL+.001)/DL)/(2*PI*(CONT/(PI*DL))*CON(1))
C TC=QIN*10.E-3/(CON(2)*20*60.E-3*10.E-3)
TC=(QIN/2)*1.E-3/(CON(4)*CONT)
TD=QIN*20.E-3/(CON(3)*1.94*5.E-3)
TE=(QIN/2)*25.E-3/(CON(3)*1.94*5.E-3)
TMAX=TOUT+TL+TB+TC+TD+TE
I=I+1
SOUT(1,I)=FS
SOUT(2,I)=TOUT
SOUT(3,I)=TMAX
SOUT(4,I)=VS
SOUT(5,I)=RES
SOUT(6,I)=PS
SOUT(7,I)=VL
SOUT(8,I)=REL
SOUT(9,I)=PL
SOUT(10,I)=PT
FS=FS+0.3
IF(I.LT.13) GOTO 10
WRITE(*,1500)(SOUT(1,J),J=1,13)
WRITE(*,1510)(SOUT(2,J),J=1,13)
WRITE(*,1520)(SOUT(3,J),J=1,13)
WRITE(*,1530)(SOUT(4,J),J=1,13)
WRITE(*,1540)(SOUT(5,J),J=1,13)
WRITE(*,1550)(SOUT(6,J),J=1,13)
WRITE(*,1560)(SOUT(7,J),J=1,13)
WRITE(*,1570)(SOUT(8,J),J=1,13)
WRITE(*,1580)(SOUT(9,J),J=1,13)
WRITE(*,1590)(SOUT(10,J),J=1,13)
1500 FORMAT('0'/'0'/'
+ '0',15X,'Flow (l/min) : ',13(3X,F4.1))
1510 FORMAT('0',15X,'Output water temp (oC) :',13(3X,F4.1))
1520 FORMAT('0',15X,'Max temp in beam (oC) :',13(3X,F4.1))
1530 FORMAT('0'/'0',15X,'Coiled tube'/
+ '0',15X,' Water speed (m/s) :',13(3X,F4.1))
1540 FORMAT('0',15X,' Reynolds number :',13(1X,F6.0))
1550 FORMAT('0',15X,' Pressure drop (bar) :',13(3X,F4.1))
1560 FORMAT('0'/'0',15X,'Long tube',/
+ '0',15X,' Water speed (m/s) :',13(3X,F4.1))
1570 FORMAT('0',15X,' Reynolds number :',13(1X,F6.0))
1580 FORMAT('0',15X,' Pressure drop (bar) :',13(3X,F4.1))
1590 FORMAT('0'/'
+ '0',15X,'Total pressure drop (bar):',13(3X,F4.1))
END

```