

EUROPEAN ORGANIZATION FOR NUCLEAR RESEARCH

Inquiry IT-2157/PS

**TECHNICAL SPECIFICATION OF THE
PULSED POWER CONVERTERS FOR THE LEAD-ION
VERTICAL BEAM DISTRIBUTOR**

Specification PS-PO / 93 -1

F. Voelker, february 1993

Summary

A prototype power converter has to be developed and four production units manufactured within a short time schedule.

The pulsed power converters will have an output power of 5 kW. They consist of a 2.5 kV charging section, of a 1 kJ energy storage and pulse forming discharge section and of the corresponding electronics and auxiliary circuits.

The equipment is required to perform a set of very demanding performance features and to make use of advanced pulse techniques. Consequently the specification is addressed to firms having a strong specialized expertise in the field.

TABLE OF CONTENTS

1. INTRODUCTION

2. SCOPE OF THE CALL FOR TENDERS AND GENERAL CONDITIONS

3. BOUNDARY CONDITIONS

- 3.1 CERN specific computer control, timing and operation interface
- 3.2 400 V utility supply
- 3.3 Load characteristics
- 3.4 Installation and cabling
- 3.5 Operating environment and cooling
- 3.6 Dummy load
- 3.7 Applicable international standards, workmanship standards and quality requirements.
- 3.8 Safety requirements
- 3.9 Technical documents
 - 3.9.1 Documents to be produced
 - 3.9.2 Approval of documents
- 3.10 Technical follow up of the order and inspections
- 3.11 Deviation from the specification
- 3.12 Tests
 - 3.12.1 Factory tests
 - 3.12.2 Provisional acceptance tests at the beginning of the guarantee period
- 3.13 Time schedule

4. DETAILED DESCRIPTION OF THE POWER CONVERTERS

- 4.1 Power converter layout and general performance specification
- 4.2 Mode of operation and design criteria
- 4.3 Detailed composition of power converters
 - 4.3.1 Power part
 - 4.3.2 Regulation electronics and monitoring circuits
 - 4.3.3 Auxiliaries
- 4.4 Construction and assembly

5. LIST OF RECOMMENDED AND SPECIFIED SUBCONTRACTORS

FIGURE CAPTIONS

Fig. 1 Beam deflection sequence and distributor excitation (case of 5 magnets).

a) Fast rise pulses

b) Inverted pre-deflector polarity and fast fall pulses.

Fig. 2 CERN Specific Computer Control Interface: General layout.

Fig. 3 CERN Specific Computer Control Interface: Cabling diagram.

Fig. 4 CERN Timing Interface: Principle diagram.

Fig. 5 Timing sequence and power converter duty cycle.

Fig. 6 BI-DIS-Pb prototype magnet module: Principle layout.

Fig. 7 Principle circuit diagram of prototype power converter.

Fig. 8 Prototype Switch assembly: Principle diagram.

Fig. 9 General layout of power converter installation.

1. INTRODUCTION

At CERN, the European Laboratory for Particle Physics Research located near Geneva/CH, a new Linac is being built to feed with Lead-Ions (Pb^{53+} at 4.2 MeV/n) the present accelerator chain Booster-PS - SPS- and eventually the future LHC. This new facility will open the way to experiments at unprecedented collision energy. The commissioning of the Linac is planned to start early in 1994.

The Booster consisting of four vertically stacked accelerator rings, the Linac beam ribbon (whose useful time-length is 550 μs) must be sliced and "distributed" to the four Booster levels. A set of ferrite magnets (BI-DIS-Pb), excited in sequence, deflects the beam slices vertically to the corresponding Booster rings and determines their length, i.e. the number of ions injected into each ring. In the present design the magnets operate in air and a ceramic vacuum chamber is placed through their aperture. The power converters, object of the present specification, will excite these special magnets.

The beam deflection sequence is schematically represented in Fig.1 (in the case of 5 magnets but the principle is also valid for 4) to point out that the beam distribution can be performed by means of magnets excited either by fast rise or by fast fall current pulses.

2. SCOPE OF THE CALL FOR TENDERS AND GENERAL CONDITIONS

This technical specification concerns the power converters of the four ferrite magnets of the BI-DIS-Pb vertical beam distributor.

The call for tenders covers the design, development, manufacturing, factory performance tests, documentation, delivery and initial commissioning at CERN of

ONE PROTOTYPE and FOUR SERIES PRODUCTION UNITS.

An auxiliary 19" rack is also part of the delivery; CERN reserves the right to add a second auxiliary rack to the order.

Once the corresponding components connected, the prototype unit shall be able to perform either fast-rise or fast-fall pulse on request (but not simultaneously). Therefore it will include more switching components than needed in the series production units. The prototype will be used for development and thorough tests and in particular to demonstrate that the operational requirements and this specification are satisfied.

The prototype power converter shall be quoted separately in the tender with a cost break-down of the parts which will not be simultaneously included in the series units, depending on the test results and the finally retained beam distribution scheme (Fig.1).

Taking the very demanding operational power converter features into account and the techniques involved in this development, only those firms should tender which have a confirmed expertise in the field. In particular they should be specialized in power electronics and have successfully built similar equipment in the last three years; they should have enough engineering strength in house to design and develop this equipment within the required short time schedule; they should have the adequate laboratory facilities and specialized instruments for this type of work.

In order to be able to compare technically equivalent offers and in view of the special power converter techniques involved as well as of the little time available for development, this specification imposes the basic solutions and design principles. The tenderer shall make an offer strictly according to this specification and shall use the components as specified.

Failure to satisfy any of these qualification criteria will be a sufficient reason for discarding the tenderer in question no matter of other aspects of his tender.

Nevertheless expert tenderers may mention in their offer technically advantageous alternative solutions which might, if approved by CERN, be evaluated during prototype development and included in the series units.

3. BOUNDARY CONDITIONS

3.1 CERN Specific Computer Control, Timing and Operation Interface

The Computer Control System of the Linac power converters will be based on a MIL- 1553 Network connected to a local G64 Bus via MIL-1553 Reception Transmission Interface (RTI) boards. Besides the RTI following Printed Circuit Boards (PCB's) are part of the specific converter control interface:

- Auxiliary power supply module
- CPU 6809
- 12 bit ADC
- 12 bit DAC
- 2 PIA
- Isolating amplifier board for magnet current monitoring

As shown in Fig. 2 two such interfaces are located in a 3U Euro-Crate. **This material is CERN delivery and will be installed in a 19" rack beside the power converter cubicles.** This rack may accept the possible parts common to all power converters (e.g. common dc link subassembly) and is part of the tenderer's delivery.

Fig. 3 shows the wiring diagram of the specific control interface and the interconnections to the power converter electronics. This must comply with the standard actuation and acquisition protocol described below. The manufacturer will receive on request additional information about the CERN control interface.

The mode of control of the power converter can be summarized as follows:

- i) The power converter will be operated either in REMOTE (via the computer control interface) or in LOCAL control mode. The converter status and possible faults/ warnings will be indicated on its front panel.
- ii) In LOCAL mode actuations are manual and the magnet current reference, proportional to the charging voltage of the Pulse Forming Network (PFN), is set by means of a ten-turns potentiometer on the front panel. Local manual OFF actuation shall be active independently of the control mode.
- iii) In REMOTE mode the power converter is controlled via its RTI and specific interface.
- iv) The standard actuation protocol is given by four exclusive actuation bits (dc signals translated into relay contacts):
 - A.OFF = main contactor open while the auxiliaries and the electronics may be powered by a separate manual switch.
 - A.ST-BY = main contactor closed; regulation, gate pulses, timing and reference signals inhibited.
 - A.ON = main contactor closed and electronics enabled so that the power converter delivers current according to the actual set point and timing sequence.
 - A.RESET = resets possible interlock memories once the fault / warning cleared and allows the converter to resume the state corresponding to the actual actuation bit.
- v) The corresponding status acquisition bits (Q.OFF, Q.ST-BY, Q.ON) detect the status of the power converter. A supplementary acquisition bit Q.UP detects whether the power converter is in REMOTE control mode and with no faults.
- vi) Up to eight INDICATOR bits are available to transmit via the RTI possible summary converter faults or warnings, such as:
 - internal (converter) fault
 - external fault
 - warning timing, etc.
 Detailed fault indicator bits are treated and displayed locally.

vii) The 0 V ground potential of the CERN Computer Control Interface will be connected to the power converter electronics at one point. All digital input/output signals will pass through isolating devices (relays or opto-coupler) in the power converter or the interface PIA's.

The connectors to be used on the cables, interconnecting the control interface to the converter electronic crate, are also indicated in Fig. 3.

The power converter operates according to a set of timing pulses corresponding to initiation of PFN charge (FOREWARNING), completion of PFN voltage stabilisation and termination of charge (WARNING), initiation of PFN discharge (START) and finally sampling of the magnet current for monitoring purpose (MEASURE).

These timing pulses are derived from the central accelerator timing system via pulse repeaters and delay units as shown in Fig.4. The timing equipment is CERN delivery and will be installed in the same 19" rack as the control interface. The timing pulses will have 25-30 V on 50 Ω and a 1 - 2 μ s duration.

The power converter must have a LOCAL-Timing simulation unit which allows the selection of free running operating frequency between 0.3 and 1 Hz (continuously or in steps) or of manual Single-Shot operation.

Concerning the Timing pulses, some simple precautions must be taken:

- i) Once a FW pulse has arrived, a complete sequence of Timing pulses (W-ST-MEA) must follow in order.
- ii) After any FW pulse no other pulse must pass during the charge time (FW-W) and in particular no START pulse.
- iii) The ST must pass only within a time window of 20 ms after the W, but 2 ms are reserved to assure that the charger is blocked and 10 ms are reserved for residual charge recovery after PFN discharge.
- iv) The pulses of the LOCAL Timing shall be used as guard pulses to complete the sequence in case any external pulse were missing.
- v) The trigger pulse for the PFN discharge will be derived from the START.

The principle of the timing pulse sequence and the power converter duty cycle are illustrated in Fig. 5.

In addition to the control interface and timing equipment some other facilities to monitor the power converter operation and observe or measure relevant signals will be installed in the same 19" rack.

3.2 400 V Utility Supply

The power converters will be supplied by an ac distribution board, fed by an 800 kVA 18 kV/400 V - 5% distribution transformer, via power switches equipped with magneto-thermic protection. The 400 V secondary star mid-point is earthed at the transformer and the neutral conductor is directly distributed to the equipment. Therefore the neutral must not be earthed at any other point.

The characteristics of the CERN 400 V ac network are the following:

- Line voltage: 3 x 400 V \pm 10%
- Frequency: 50 Hz \pm 1%
- Five conductor distribution: 3 Phases + Neutral + Earth

Complementary information about the CERN mains and the other equipment connected to the same transformer are available on request.

3.3 Load Characteristics

The power converters, object of the present call for tenders, will excite the BI-DIS-Pb ferrite magnets. A magnet prototype module is shown in Fig.6 and its characteristics are collected in Table 1. **The prototype power converter specification is based on these figures which might be slightly modified when finalizing the magnet design. Therefore the specification for the series power converters must be formally confirmed by CERN before series production can fully start.**

Table 1 - BI-DIS-Pb Magnet Characteristics

Aperture H x V (mm ²)	75 x 130
Magnetic / Physical length (m)	0.23 x 0.27
Number of turns	1
Nominal / maximum peak current (kA)	1.5 / 2
Deflection angle at 1.5 kA (mrad)	5
Nominal field intensity in gap at 1.5 kA (mT)	25
Nominal field strength in ferrite core at 1.5 kA (mT)	88
Integral field strength $\int B \cdot dl$ in gap at 1.5 kA (mT · m)	5.8
Inductance Lm (μ H)	0.54
Resistance Rm of brass winding (m Ω)	0.25
Effective current (A)	\leq 50
Core material	Ni-Zn Ferrite
Ceramic vacuum chamber with internal dimensions H' x V' (mm ²)	60 x 110

3.4 Installation and Cabling

The power converters will be erected on a false floor at 40 cm high with respect to the concrete basement. All cables will be laid in this false floor.

Cable layout inside the power converter must respect permissible current density and avoid improper overlapping. Attention must be given to the mechanical support of cables (no sharp edges, rigid fixing) and to connections (no poor contacts of high resistive value).

The power cabling shall be such as to assure the best possible Electromagnetic Compatibility (EMC) features with respect to the low level electronics of the power supply itself and to the environment.

In particular the power cabling shall be separated from the low level signal wiring and two separate 0 V "earthing" bus bars shall be foreseen for the power circuit and for the electronics.

Twisted wires, coaxial cables, shielded cables and electromagnetic screens shall be widely used whenever necessary.

The cables from the ac distribution board to the power converters will be supplied and laid by CERN.

The length of the cables between the magnets and their power converters will be less than 30 m. Up to twenty coaxial cables in parallel, type RG 213 U (96 IEC 50-7-1), will be used as pulse transmission line. These cables will be split up underneath the magnets and connected to a bus bar assembly which passes the magnet current monitoring transformer (PEARSON/USA - Type 1330). Corresponding output terminals shall be foreseen in the power converter.

The tenderer is requested to include in the offer one such current monitoring transformer and a length of 20 x 30 m of coaxial cable to be used during prototype converter tests. CERN will supply the transmission lines as well as the magnet current measuring transformers for the four series production units.

The electric power cables as well as all control and signal cables used in the power converters must be of the flame retardant halogen and sulphur free type with low smoke density, toxicity and corrosivity in case of fire. This implies e.g. the use of EPR or PE or EVA polymers both for the cable insulation and the outer sheath.

No dielectric materials and no constituents containing halogens (PVC or PCB or Teflon etc.) shall be used in any part of the power converter. The tenderer is requested to indicate in the offer the type of cables he intends to use as well as the other parts, components and materials which might not be halogen-free. CERN reserves the right to give formal approval or to ask for a change in writing.

The identification of the electrical power cables and conductors is done according to the following colour code:

i) Alternating current (ac)

- Active cables and conductors:

Unspecified phase:	brown
Phase R:	orange
Phase S:	green
Phase T:	violet
Neutral:	light blue
- Earth (ground): combination of green and yellow

ii) Direct current (dc)

- Active cables and conductors:

Positive:	red
Negative:	dark blue
Mid conductor:	light blue
- Earth (ground): combination of green and yellow

3.5 Operating Environment and Cooling

Altitude above sea level:	500 m
Ambient operating temperature:	18 to 30° C
Relative humidity:	30 to 80%

The power converters and their electronics shall preferably be natural air convection cooled and the internal enclosure temperature should not exceed 40°C for 30°C ambient during two hours continuous operation at full power.

The use of natural air convection cooled heat pipes or the presence of few temperature controlled silent blowers may be accepted if the first solution reveals to be difficult.

3.6 Dummy Load

The magnet load is assimilated to a LR impedance and therefore the successful tenderer will procure an equivalent dummy load for development and factory tests of the power converters. Considering the magnet impedance this is expected to be easy and inexpensive. The dummy load will be delivered to CERN together with the last power converter.

3.7 Applicable International Standards, Workmanship Standards and Quality Requirements

In general the equipment must conform to IEC standards and recommendations. Other European Technical Standards will be applied for particular aspects (e.g. VDE 870 for EMC).

Workmanship quality must exceed the "acceptable" level according to the MARTIN MARIETTA Standards, which will serve as reference.

Printed Circuit Boards (PCB's) shall be used in the power converter electronics. While the manufacturer will probably use as far as possible his standard PCB's the number of modifications done on them (added components and wires, cut metallized paths etc.) shall be limited to < 5. In case of more modifications CERN reserves the right to reject the PCB's and demand that new dedicated ones be made free of charge and without delaying the time schedule.

3.8 Safety Requirements

The equipment shall comply with the legal safety regulations of the host countries of CERN (the most stringent Swiss or French clause shall apply for each aspect of the regulation).

Particular attention shall be brought to all aspects concerning personnel safety.

It is requested that the power converter cubicles be equipped with microcontacts on the doors, that all live parts at a voltage > 50 V be protected by perspex panels against inadvertent contact, that metallic frames, doors and magnetic circuits be earthed, that components be clearly identified and H.T. warning labels used, that capacitor banks be equipped with external discharge resistors and short-circuiting devices etc.

The PFN capacitors will be discharged via a resistance by an automatic H.T. relay (ROSS/USA) when the power supply is put OFF. A manual lockable short-circuiter shall also be provided.

The conformity of the equipment and of the total installation will be controlled at CERN by a safety engineer before starting operation and the manufacturer may be asked to correct free of charge the safety aspects not complying with this specification.

3.9 Technical Documents

3.9.1 Documents to be produced

CERN requests the following technical documentation:

i) With the tender:

- Brief description of the proposed power converter and of its mode of operation, including design calculations and relevant computer simulations available.
- Circuit diagram of the power part and block diagram of the electronics.
- Preliminary drawings showing layout, composition and views of power part and electronics, location of main components and overall dimensions.

- A list of components illustrating their characteristics and rating and indicating the suppliers and subcontractors.
- The proposed time schedule for procurement of material, assembly and testing of prototype and manufacturing of series production units.

N.B. Not joining these documents to the tender will be a sufficient reason for disregarding the tenderer.

ii) After placing the order, technical documents to be submitted to CERN for formal approval before assembly of the prototype can start:

- Final design calculations and relevant computer simulations.
- Final circuit drawings, block diagrams and a complete list of components, suppliers and subcontractors.
- Updated data sheets of all relevant components and pieces of equipment.
- Wiring diagrams of the power converters and their electronics.
- Mechanical drawings of the complete cubicles and subassemblies.
- Updated time schedule for procurement of components, assembly of prototype and series production of power converters.
- Drawing of the power converter front panel including the proposed synoptic circuit diagram.

iii) At delivery of the prototype power converter:

- A complete set of final documents including detailed circuit diagrams of power part and electronics, updated list of components and their data sheets, electro-mechanical layout drawings of cubicles and subassemblies, drawings of cable terminal blocks.
- Preliminary drawings of the printed circuit boards (circuit diagram, component side and back side) and list of components and test points of every PCB.

iv) At delivery of the last series production unit:

- Two additional copies of the documentation under iii).
- Copies of the final drawings of all printed circuit boards (circuit diagram, component side and back side) and final list of components of each PCB.
- Brief description of the mode of operation of each electronic PCB and of the necessary adjustment procedures at commissioning.
- User instructions for installation, operation and maintenance of the power converters.

N.B. Deliveries to CERN must include the above documentation before the contract conditions are deemed to be met. In his offer the tenderer shall quote separately for the requested documentation.

3.9.2 Approval of Documents

The technical documents requested at the different stages of the contract will be discussed with the tenderer before placing the order.

The documentation will be an integral part of the contract.

CERN will formally approve the above documents and express his remarks in the course of the order according to the attached time schedule (see 3.14).

3.10 Technical Follow up of the Order and Inspections

CERN is aware that a competent follow up of the contract and in depth discussions with the manufacturer during the power converter design, development and manufacturing steps are an important factor for success.

The manufacturer shall nominate a senior specialist to be responsible for the project and to organize at appropriate intervals (or at any time on simple request of CERN) meetings with CERN representatives. The discussions and the progress will be recorded in minutes a copy of which shall be sent to the participants within 3 days.

CERN shall be allowed to visit at any time during the contract the manufacturer's and the subcontractor' s premises.

The persons in charge of the technical follow up of the contract on behalf of CERN are:

F.VOELKER / PS-PO	seconded by	G.SIMONET / PS-PO
Tel. 004122-767 25 74		Tel. 004122-767 25 28
Fax 004122-767 05 15		Fax 004122-767 82 00

These persons are at the tenderer' s disposal for any clarification of this specification and to discuss detailed technical aspects before placing the order and in the course of the contract.

3.11 Deviation from the Specification

All proposed deviations from the present technical specification must be submitted to CERN in writing. CERN will give its approval or refusal also in writing.

3.12 Tests

3.12.1 Factory Tests

Extensive factory tests shall be carried out to demonstrate that the different aspects of this technical specification are met and that the power supplies can perform their duty satisfactorily. A CERN representative will witness these tests.

i) Tests on all power converters will include:

- Verification of the power supply assembly and wiring according to the circuit diagrams and other technical documentation.
- Verification of the layout and mode of operation of sub-assemblies and electronics.
- Insulation test of the power part to ground according to IEC.
- Operation at reduced power on the dummy load at a pulse repetition frequency up to 1 Hz.
- Full power operation under LOCAL Reference, Timing and Command conditions at nominal repetition frequency over 2 hours (4 hours on prototype unit).
- Tests simulating the REMOTE Reference, Timing and Command situation.
- Verification of all test and monitoring signals as well as of all protection and interlock functions.
- All other tests which CERN may consider important in relation to the final operating conditions of the equipment.

ii) Additional tests on prototype power converter:

During the development of the prototype converter additional tests shall be carried out to demonstrate that the design and technical solutions fully meet all performance requirements both for fast rise and fast fall pulse mode. Partial tests on single power converter components and sub-assemblies will also be done on request of the CERN representative.

N.B. The manufacturer is expected to make available during the tests all instruments, equipment and staff needed for effective work. The development of the prototype converter will require particular tests on low power laboratory mock-up assemblies (see 4.2).

3.12.2 Provisional Acceptance Tests at the Beginning of the Guarantee Period

Once the delivery completed and the power converters installed at CERN, the manufacturer will be invited to begin formal commissioning for provisional acceptance of the equipment delivered.

The guarantee period will start when the power converters have been successfully commissioned by the manufacturer at CERN. Commissioning is planned to take place as soon as possible after equipment installation and interconnection.

3.13 Time Schedule (*)

CERN demands the pulsed power converters to be developed, manufactured tested and delivered according to the following time schedule:

i) PLACING OF THE ORDER	(Weeks from):	0
ii) DEVELOPMENT AND MANUFACTURING OF PROTOTYPE POWER CONVERTER		
Test of salient development topics on a low power mock-up circuit as mentioned under 4.2		4
Submitting of the technical documents to CERN for approval		6
Technical discussions with the manufacturer, approval and possible modification of technical documents		10
Start of prototype assembly and development of sub-assemblies		12
Completion of prototype converter development		30
Completion of factory tests on prototype power converter		34
Formal approval of prototype power converter		36
Delivery of prototype power converter at CERN		40
iii) MANUFACTURING OF FOUR SERIES PRODUCTION UNITS		
Start of manufacturing of sub-assemblies		24
Confirmation of series power converter specifications		28
Start of power converter production		28
Completion of power converter manufacturing		42
Completion of factory tests		48
Delivery of last series production unit at CERN		50
Beginning of commissioning of power converters at CERN		a.s.a.p

(*) The possible annual 2-4 weeks factory closure period will be added to this time schedule.

4. DETAILED DESCRIPTION OF THE POWER CONVERTERS

4.1 Power Converter Layout and General Performance Specification.

The power converter consists of:

- A POWER PART, assembled and wired in a cubicle, including
 - i) The charging section
 - ii) The Pulse Forming Network energy storage section
 - iii) A set of semiconductor power switches
 - iv) The pulse transmission line
 - v) The active filter.
- A fully equipped ELECTRONICS crate.
- The AUXILIARIES

The power converter layout is illustrated in Fig.7 and its main characteristics are collected in Table 2.

4.2 Mode of Operation and Design Criteria

The energy storage PFN capacitance will be charged at constant current, or preferably at constant power, within 400 ms.

Thereafter the PFN voltage will be stabilized before blocking the charger and preparing the circuit for discharge.

The PFN will be discharged into the magnet by solid state switches via a pulse transmission line to provide the specified trapezoidal excitation pulse performing either fast rise or fast fall time (prototype power converter).

At the end of the pulse a special switching circuit will possibly clamp the PFN voltage to zero or recuperate some of the residual charge.

The power converters are requested to operate reliably up to 6000 h a year with virtually no interruption.

Table 2 - Characteristics of BI-DIS-Pb Power Converter

Input ac connection	3ph-50 Hz-400 V
Standard control protocol	OFF / STAND-BY / ON / RESET
Standard timing pulses	FOREWARNING / WARNING / START / MEASURE
Nominal pulse repetition frequency (Hz)	1
Operational control range of PFN current (% of nominal value)	10 - 100
Charging time of energy storage PFN (ms) (*)	400
Stabilisation time of PFN capacitor voltage (ms)	20
Blocking time W-FW to allow PFN discharge and voltage recovery (ms)	20
Peak nominal PFN charging voltage (V)	2500
PFN voltage reversal during pulse (%)	100
Long term PFN charging voltage stability and precision (%)	<± 0.1
Linearity of PFN voltage with respect to current reference (%)	<± 0.5
Current pulse shape	Trapezoidal
Peak/RMS nominal magnet current (A)	2000/50
Useful current pulse flat top duration (µs)	>550
Total current pulse base duration (µs)	~700
Magnet current pulse rise time 10-98 % (µs) (**)	< 3
Magnet current pulse fall time 98-10 % (µs) (**)	< 3
Sum of pulse overshoot/undershoot, flat top ripple and droop (%)	<± 0.3
Long term current flat top stability and precision (%)	<± 0.1
Load resistance/inductance [magnet and connections] (mΩ/µH)	< 1.0/1.0
Transmission line dc resistance (mΩ)	> 12
Nominal value of PFN energy storage capacitance (µF)	< 400
Mean dc output current (A)	2
DC output converter power (kW)	5
PFN characteristic impedance Zc (Ω)	1.25
Transmission line characteristic impedance [50/Nb.of cables] (Ω)	> 2.5

*) The charging time of 400 ms is imposed by the fact that the refresh of reference setpoints, via the computer control system, occurs about 0.45 s before the next beam operation and that the possibility of pulse to pulse set-point modulation is not excluded.

**) Two possible beam deflection schemes using either fast rise or fast fall power converters are considered, as mentioned in chapter 1. Both solutions shall be developed and tested on the prototype converter. One or the other will then be retained for the series production units depending on the result of these tests.

The design of the power converter is based on the following criteria:

- The pulse length T_p imposes the use of a lumped element PFN. In principle the capacitors will have constant value and the inductors will be mutually coupled.

Particular low effective network resistance is required to limit the pulse droop and drift. The PFN will be developed and adjusted at low voltage (50 V) by using as switches mercury wetted relays and fast diodes .

- The PFN current pulse is specified for an unusually high ratio between flat top duration and rise/fall time $T_p/T_{r,f}$.

- The PFN charging voltage U_c is kept low in order to be able to use solid state switches with no series connection, instead of thyratrons.

- The total length of the distributor magnets as well as their aperture, which depends on the actual beam envelope, are imposed. The beam deflection angle is given by the $\int Bx dx$ along the particle trajectory. The gap H of the monotum magnet requires a rather high excitation current I for its nominal magnetic induction $B = (\mu_0 \cdot I) / H$.

- As a first consequence the PFN has low characteristic impedance Z_c and is operated in short-circuit mode, hence $I = U_c/Z_c$.

- A conventional PFN design for fast rise time would require an excessive number of cells (>200) leading to a difficult construction and operation. Therefore it was decided to base the PFN design on a much smaller (>10) number of cells and to include a special head-cell to perform the fast rise time as well as an active flat top ripple filter.

- Fast fall time, the alternative of the fast rise time PFN to be tested on the prototype power converter, is achieved by diverting the PFN current, while simultaneously interrupting the output and making the magnet current free-wheel through a resistive path. The interest in the fast fall time solution is justified by its possible more favourable pulse shape as far as beam deflection concerns.

- The pulse transmission line is mismatched with respect to the pulse generator impedance. The mismatch is reduced by putting a sufficient number of (50 Ohm) cables in parallel, assuming that such a short line will not deteriorate the pulse shape.

- A switch-mode IGBT resonant charge regulator will be used to assure the target performance features. This technique is considered to give best overall results in case of a relatively fast PFN charger concerning mains power factor, harmonics, speed and accuracy of regulation, EMI, efficiency and compactness.

N.B. The main issues regarding the design and development of the prototype power converter are:

- The selection of the PFN capacitors and of the best number of cells.
- The construction of the cell inductors and the method to adjust the main and mutual PFN inductances.
- The design of a suitable inductance-free head-cell.
- The matching of the head cell to the PFN and to the switches.
- The development of the fast rise-time and fall-time schemes.
- The development of the active filter and its integration into the current regulation loop.

CERN requests the successful tenderer to explore these design aspects on a low power mock-up circuit immediately after placing the order and reserves the right to witness these preliminary development tests and to participate in the technical discussions.

4.3 Detailed Composition of Power Converters

4.3.1 Power Part

i) Charging section

- 400 V 3ph input ac circuit including:
 - Phase presence indicating neon lamps.
 - A key-locked fuse link isolator (F1) and a main circuit breaker (SW1) equipped with thermo-magnetic protection and electromagnetic actuation, associated with a transformer premagnetizing and capacitor soft charging circuit (SW2 and SW3). Preference will be given to a modern electronic transformer inrush protector (eg. type TSE 20 manufactured by TRAFOSCHNEIDER or by RIBA).
 - An ACCT to measure and observe the line currents.
 - LCR filters to decouple the converters from each other and from other power electronics equipment fed by the same distribution board.
 - Switch ON-STBY-OFF sequence relay circuit with appropriate safety conditions and time delays (e.g. deblocking of electronics after switching ON the power part and blocking it before switching OFF etc.).

- Intermediate dc link including:

- An optional adapting/isolating Delta/Star transformer (TR1), which may have secondary taps for 360/400/440 V primary voltage.
Clicson thermocontacts, connected in series, will be mounted on each winding.
- A Graetz-bridge diode rectifier (D1-D6) to charge a capacitor bank C_o via a choke L_o . This will have two separate windings equipped with thermo-contacts. Its laminated iron core will have a distributed air gap and be dimensioned for the inrush filter current. The capacitor C_o will be a high performance electrolytic type with adequate voltage, ripple current, operating temperature and life ratings.
- A LEM DCCT will allow to measure and observe the dc-link current.
- A fuse link isolator (F2) may be connected in front of or behind the capacitor bank C_o .

N.B. If considered an advantage for the four series units, the ac input circuit and dc-link could be common to all four series power converters and be located in the lower half of the auxiliary 19" rack foreseen for the CERN equipment (Timing, computer control interface etc.) or in a separate rack. In this case the problem of switching ON/OFF individual power converters, and of isolating them in case of intervention, is to be solved.

- Charge switch-mode regulator and H.T. circuit including:

- A half- or full-bridge double resonant IGBT converter (IGBT1-IGBT4) operating at a frequency > 20 kHz and feeding a number m of series connected H.T. fast rectifiers (D_a - D_m), via step-up transformers having ferrite core and Litz windings (TR_a - TR_m).
- An air core inductance (L_o'), designed to smooth the charge current, protect the rectifiers during PFN discharge and to get satisfactory PFN charge recovery after discharge through diode D_7 (which also protects the fast diode rectifiers D_a - D_m).
- LEM DCCT's/DCVT's to monitor the current for the charge regulation, the PFN voltage (two separate DCVT's are requested for voltage regulation and front panel monitoring) and the charge recovery current.

ii) Energy storage PFN

A design with constant cell capacitance is specified (this implies mutually coupled adjacent cell inductances in the normal case without active ripple filter). Nominal values of inductance and capacitance are given here. The capacitors will be selected within their tolerance limits of $\pm 10\%$.

The reference PFN consists of a special head cell and 10 LC cells. Capacitor units of $6 \mu\text{F}$ will be used for the prototype and be connected in parallel as required.

In the possible case where, to achieve the specified pulse characteristics in practice, faster natural PFN rise time and finer pulse tuning might become necessary, a large number of cells could be easily obtained by redistributing the capacitors while the head-cell and possibly the inductors would have to be redesigned.

Consequently the basic prototype PFN design will be as follows:

- Head cell (reference design to be adapted to the real PFN)

One key target feature of the head-cell and switches assembly must be the extremely low circuit inductance. In the reference design the head cell includes a fast diode D7 which will be tested on the prototype PFN.

- Capacitors: ($C'_{hc} = 20 \mu\text{F} + C''_{hc} = 2 \mu\text{F}$), impregnated mixed dielectric, type HW-LCC (***), designed for a charge voltage of 2500 V dc (which they must withstand indefinitely) and a repetitive discharge at up to 1 Hz repetition frequency. The specified dv/dt is $2500 \text{ V}/\mu\text{s}$ and voltage reversal during discharge may be 100% depending on the final circuit layout (i.e. 5 kV capacitors must be used).
- Inductors: air core solenoids ($L'_{hc} = 100 \mu\text{H}$, $< 5 \text{ m}\Omega + L''_{hc} = 3 \mu\text{H}$) wound with Litz Cu-conductor or with Cu- or Al-band. The inductance of each solenoid must be adjustable.
- Resistors: preliminary resistance values are $R'_{hc} = 1.25 \Omega$ and $R''_{hc} = 20 \Omega$.

- LC cells ($n \geq 10$)

- Capacitors: (C_1 to $C_{n-1} = 24 \mu\text{F} + C_n = 36 \mu\text{F}$) i.e. $50 \times 6 \mu\text{F}$ for the prototype including some spares. Metallized polypropylene film dielectric; FPG/LCC dry type or PPX/LCC impregnated type (***), designed for a charge voltage of 2500 Vdc (which they must withstand indefinitely) and a repetitive discharge at up to 1Hz repetition frequency with 100% voltage reversal. The specified maximum dv/dt is $1500 \text{ V}/\mu\text{s}$. Capacitors of the 5 kV class must be used.

(***)

CERN has worked out the special head cell configuration to obtain the fast rise time with minimum overshoot and ringing as well as the proposed alternative switching scheme for fast fall-time. These solutions have been computer simulated but not yet tested in practice and finalizing the PFN design is part of the prototype power converter development.

- Inductors: Air core solenoids (L_2 to $L_n = 38 \mu\text{H} + [L''_1 + L''_1] = 60 \mu\text{H}$), $R < 3 \text{ m}\Omega$, wound with Litz Cu-conductor or with Cu- or Al-band. [L''_1 is shown as an inductor-transformer in Fig.7 but may be a simple inductor used for active filter insertion]. The effective resistance of the inductors must be as low as possible. The value of each inductance as well as the mutual coupling between adjacent cells must be fine-adjustable. Among the dozen possible tuning techniques a suitable one will be proposed by the tenderer and discussed with CERN for approval. Mutual coupling between not-adjacent cells must be avoided.

iii) PFN discharge and switching section (Fig. 8)

The PFN is discharged by a GTO solid state switch driven on/off by a special gate drive circuit via optical links. The GTO being asymmetric for faster operation, a series diode is needed to take the reverse voltage; if this diode is fast enough no other anti-parallel diode to the GTO is required. Suitable snubber components are part of the main GTO switch assembly. A small saturating reactor may be put in series to the GTO to limit the initial high di/dt , due to the cable and stray capacitances, without affecting the rise time.

In the alternative fast fall-time scheme the GTO must switch off a peak current of 2000 A. A crowbar thyristor is used to divert the PFN current together with a free-wheeling diode and resistor path.

The tenderer shall propose suitable solutions for each of the power converter switches and, to cope with any contingency, he shall include two GTO assemblies and gate drive units in the quotation of the prototype power converter.

Technical discussions have been conducted with two firms concerning the delivery of complete GTO assemblies, including the associated drive circuit and the other switches, namely:

- **GEC-PLESSEY** (Ref. E52700 / Stack PH9390-470/1 for GTO and PH9399-470 for crowbar)

- GTO (Th1) : DG758BX40
- Series diode (D8) : DSF21545SX40
- Anti-parallel diode (D9) : Not required
- Crowbar thyristor (Th2) : TN93438 (4.0 kV max.)
- GTO snubber: Diode (D10) : DSF8045SK40
C= 4 μF
R= 6.6 Ω , 25 W, Aluminium clad
- Series diode (D8) snubber: C= 1 μF
R= 28 Ω
- Crowbar thyristor (Th2) snubber: C= 1 μF
R= 28 Ω
- GTO gate drive unit: GDU90-20402 (*)

- **WESTCODE Semiconductors** (Ref. WSE-020-RY / Stack U5049/136 for GTO and U3029/129 for crowbar)
 - GTO (Th1): WG20045SP on clamp CMK3000
 - Serie diode (D8) : SM45CXC604
 - Anti-parallel diode (D9) : SM45CXC604
 - GTO snubber : Diode (D10) : SM45CXC364
C= 4 μ F
R= 20 Ω
 - Crowbar thyristor (Th2) : D315CH 35F2D0 on clamp CMK2140
 - GTO gate drive unit: Manufacturer NADA (*)

iv) Pulse transmission line

A number of coaxial cables (part of the delivery only for the prototype power converter) will connect the power converter to the magnet. Their final number will be determined in the course of the development as function of the actual pulse shape.

The coaxial cables will be connected under the magnet to a terminal bus bar arrangement passing through and around the current monitoring transformer (PEARSON/USA - Type 1330 - 5 V/kA, **part of the delivery only for the prototype power converter**).

v) Active filter

It consists of a class-C amplifier, driven by a high impedance differential stage, of auxiliary components and power supply. The active filter is inserted in a fast current flat top regulation loop. It will cope typically with magnet current ripple of a few percent and withstand the voltage appearing across the insertion transformer-choke L''_1 during the pulse.

The active filter is inhibited during current rise- and fall-time and will enter into action when the Ldi/dt voltage across the transformer-choke is under a certain level. This device shall be tested during the development of the prototype power converter.

If working satisfactorily the active filter is expected to greatly simplify the design, construction and tuning of lumped Pulse Forming Networks in general. The active filter current is monitored by a separate DCCT (HOLEC/NL- Type 500 SEP or PEARSON - Type 110, **part of the delivery for all power converters**).

(*) Modified version of existing unit to give $I_{gm(on)} = 100+200$ A and $dI_g/dt = 50+100$ A/ μ s.

4.3.2 Regulation Electronics and Monitoring Circuits

The power converter electronics shall be accommodated in a double-3U or a 6U 19" Euro-crate; Euro-card PCB's of the same 160 or 220 mm length shall be used. The tenderer shall propose a front panel layout and CERN reserves the right to modify or adapt it to its own standard. LED indicators and monitoring points (e.g. LEMO coaxial plug size 00) on the front panel will facilitate operation and servicing.

The functional units of the electronics are mainly the following:

- The change-over switch selector of LOCAL/REMOTE mode of operation and the local ON/OFF/STBY/RESET command module.
- The timing module and mode selector (External Timing or Local timing simulator).
- The interlock and protection module. The number of internal and external interlock/ warning signals will not exceed 16. A preliminary list is given as base for the tenderer's proposal:
 - Doors
 - Over voltage (intermediate dc link or output voltage)
 - Over current (ac, dc, output current or active filter current)
 - Over temperature (magnetic components, IGBT's or other power semiconductors)
 - Fuses (ac, dc link, active filter or others)
 - Emergency (red button)
 - Driver fault (GTO's or IGBT driver)
- The PFN voltage regulation and active filter regulation PCB's including on the front panel the ten-turns potentiometer for LOCAL magnet current reference setting, the potentiometer for adjustment of the ratio between magnet current and capacitor voltage and the relevant monitoring plugs (magnet current set-point, charge current and voltage, charge recovery current, magnet and active filter current).
- The pre-drive, optical link and supervisory unit for the switch-mode IGBT charge-regulator (the drivers are assumed to be located close to the IGBT modules).
- The pre-drive, optical link and supervisory unit for the GTO discharge and the other solid state switches.
- An emergency stop unit (red button).
- A unit carrying the panel instruments for charge voltage and current (preference is given to slim profile horizontal or vertical LED-bar or needle instruments of the 1% class) as well as a S/H three digit DVM of the 1% class with LCD display, indicating the value of the magnet current (0.00 + 2.00 kA) at the (LOCAL) MEASURE timing instant.
- Auxiliary power supply modules as required.

The detailed layout of the electronics will be discussed with the successful tenderer during the early design stage of the order.

4.3.3 Auxiliaries

All auxiliary power supplies for the electronics, the active filter and the relay circuits will be part of the delivery, as well as any other auxiliary component or circuit required to fulfil the specification or to operate the power converter as foreseen.

A number of auxiliary components (e.g. snubber and RC circuits) not shown in Fig.7 and 8 may be required for satisfactory operation and therefore be part of the delivery.

CERN requires an ac distribution unit (RITTAL DK 7273), with 5 Swiss standard sockets, to be installed in each power converter and in the auxiliary rack to supply the electronics and auxiliary power supplies as well as external instruments as needed.

All DCCT's and PEARSON measuring transformers inside the power converters are part of the delivery for all units.

Mains filters shall be installed on the ac input in the electronics crate (SCHAFFNER/CH type FN 322-3/05).

A synoptic circuit diagram is required on the front panel of the power converter.

4.4 Construction and Assembly

The power converters will be located in an existing equipment room at CERN where the available space is very limited; consequently there is a strong interest in a compact design without worsening the component accessibility and the EMC situation.

A preliminary layout of the four series power converters, of the prototype / spare unit and of the auxiliary 19" racks, as they will eventually be installed at CERN, is shown in Fig. 9.

The power converters shall be of modular construction; facilities for easy handling and transporting the cubicles shall be provided. Maximum dimensions (W x D x H) of the power converters should not exceed (1.2 x 0.8 x 2) m³.

RITTAL cubicles of the PS 4208 and PS 4608 type, equipped with HF/EMI protection, are specified. The standard RITTAL cubicle colours (inside yellow / outside grey) are accepted.

The manufacturer shall use as much as possible the pre-fabricated accessories and subassemblies which are part of the RITTAL program (e.g. ac, distribution units, separating panels and supports etc.).

It is of great importance to achieve a compact inductance free layout of the PFN capacitors; therefore L or U shaped Al profiles should be used as support of the PFN.

Particular attention shall be brought to all aspects concerning equipment operation and maintenance as well as personnel safety. Bus bars, components, cable connections and mechanical assemblies shall have no sharp dangerous corners.

All cables, wires and components shall be identified and numbered.

All magnetic components and subassemblies shall be earthed.

Only metric screws as well as DIN 46277 mounting profiles must be used.

5. LIST OF RECOMMENDED AND SPECIFIED SUBCONTRACTORS

Recommended subcontractors:

- Magnetic components :
 - TRANSFORMATEURS BC / F
Z.I. Allée des Justices
85200 Fontaney Le Conte
Fax 0033 51510645
 - TRAFOMEC / I
06068 Tavernelle (Perugia)
Via Pievaiola Z.I.
Fax 0039 75 8355388
 - TRASFOR SA / CH
P.O. Box 231
CH-6903 Lugano
Fax 0041 91 732460

- Transformer inrush current limiter :
 - TRAFO SCHNEIDER / D
Waidmattenstrasse 8
D-7806 March-Buchheim
Fax 0049 7664 60617
 - RIBA GmbH / D
Gewerbstrasse 19
D-7801 Schallstadt
Fax 0049 7664 60617

Specified subcontractors:

- Current measuring transformers :

HOLEC / NL
 Holec Industrial Systems
 Heemaf BV P.O. Box 23
 7550 AA Hengelo
 Fax 0031 74 430399

LEM SA / CH
 Case Postale 785
 1212 Grand Lancy 1
 Genève
 Fax 0041 22 7949478

PEARSON ELECTRONICS Inc. / US
 1860 Embarcadero Road
 Palo Alto
 California 94303
 Fax 001 415 494 6716

- GTO's and other PFN discharge switches :

GEC PLESSEY / UK
 Power division
 Att. Mr. R. Eveleigh
 Carholm Road
 Lincoln LN1 1SG
 Fax 0044 522 510550

WESTCODE Semiconductors Ltd. / UK
 Att. Mr. R. Youdan
 P.O. Box 57 Chippenham
 Wiltshire, England SN15 1JL
 Fax 0044 249 659448

- GTO Gate Drive Unit (other than GEC-PLESSEY) :

NADA ELECTRONICS Ltd. / UK
 Att. Dr. D. Gurwicz
 Plumb Centre - Hawks Road
 Gateshead
 Tyney Wear, England NE8 3BL
 Fax 0044 91 4776678

- PFN capacitors (*) :

THOMSON-LCC / F
 Direction et Services Commerciaux
 Att. Mr. C. Veron
 50, Rue J.P. Timbaud - BP 13
 92403 Courbevoie Cedex
 Fax 0033 1 49053901

- Power converter cubicles and auxiliary racks :

RITTAL AG / D
 Ringstrasse 1
 5432 Neuenhof
 Fax 0049 56 864242

- Ac mains filters and EMI components :

SCHAFFNER ELEKTRONIK AG / CH
 Nordstrasse 11
 4708 Luterbach
 Fax 0041 65 424332

- H.T. discharge relay :

ROSS Engineering / US
 559 Westchester Drive
 Campbell, CA. 95008

(*) For technical assistance concerning the PFN construction one can contact :

Mr. E. Decailloz
 THOMSON-LCC / F
 ST APOLLINAIRE
 Avenue du Colonel Prat
 21850 St.Apollinaire.
 Tel. 0033 80717560
 Fax 0033 80701347

His reference of PFN technical dossier :

92EFX328.

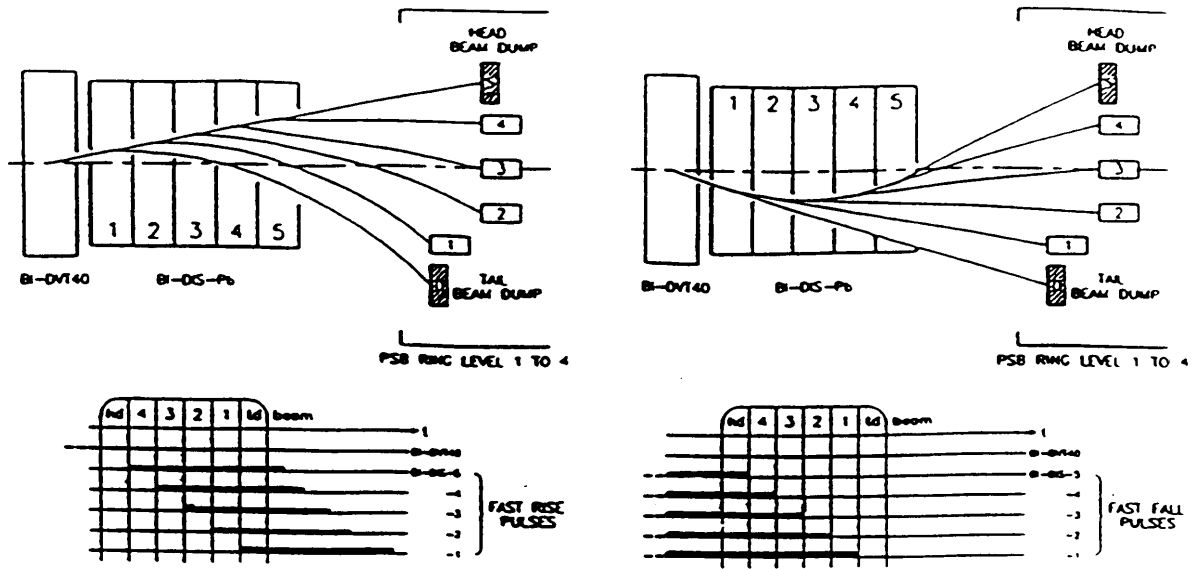

Fig. 1 Beam deflection sequence and distributor excitation (case of 5 magnets).

- a) Fast rise pulses
- b) Inverted pre-deflector polarity and fast fall pulses.

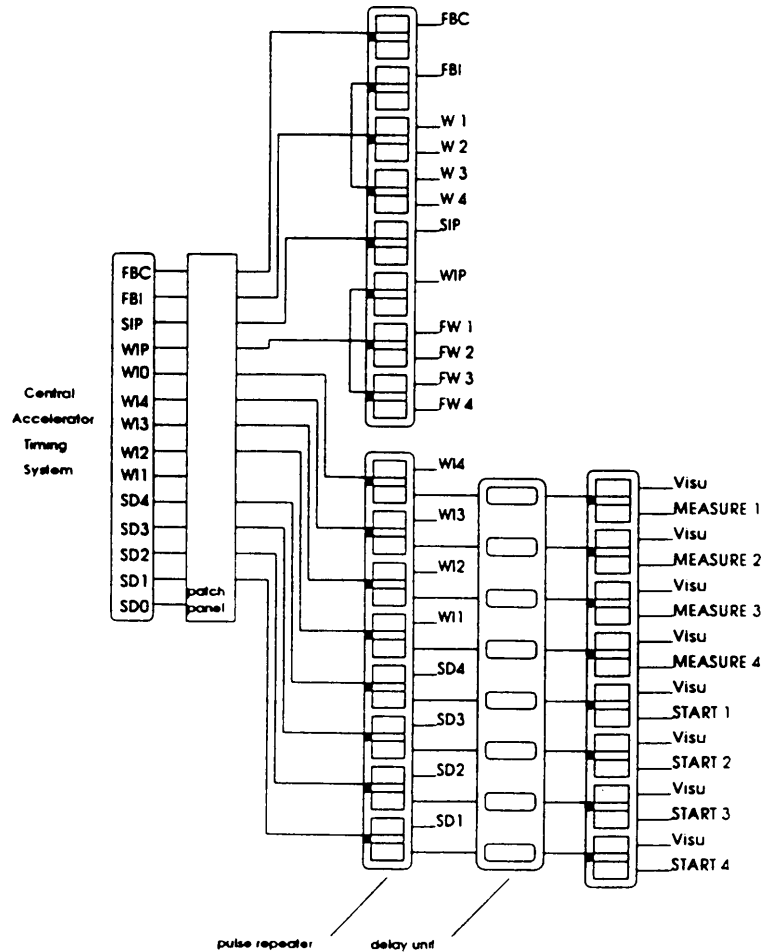
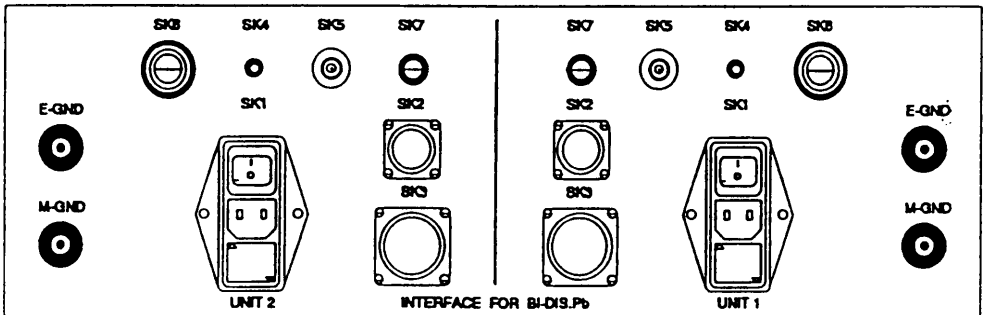
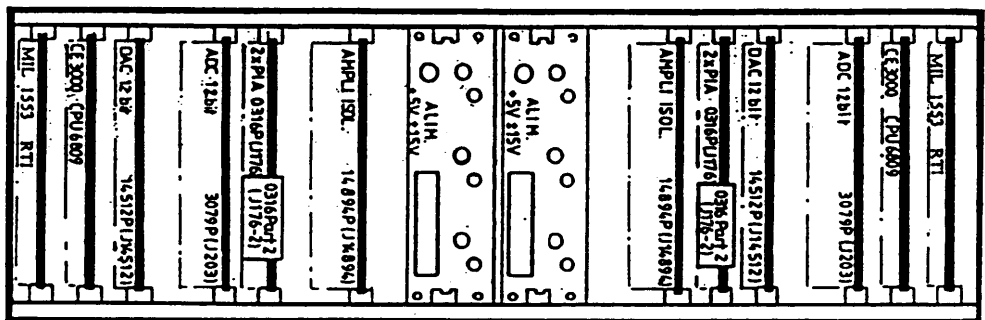
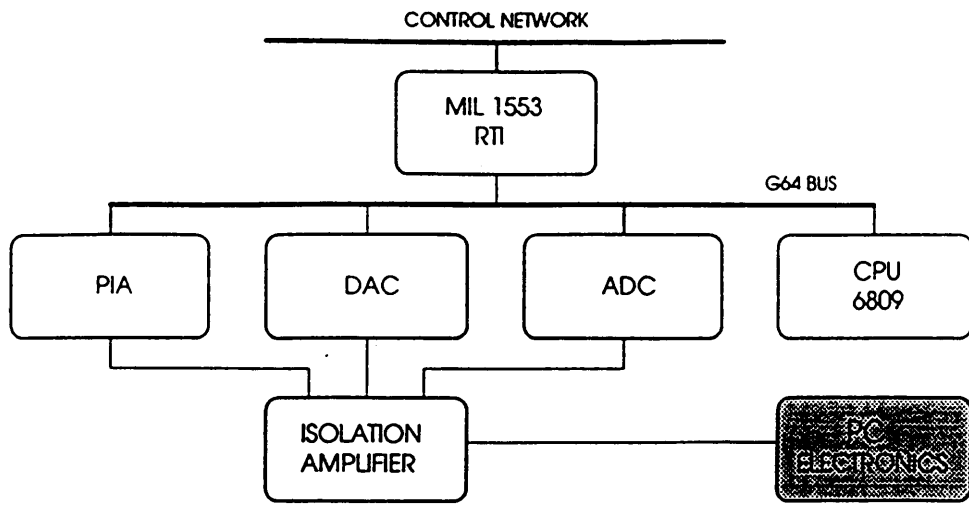

Fig. 4 CERN Timing Interface: Principle diagram.



- | | | |
|-----|-------------------------|------------------------------------|
| SK1 | 220V | SCHAFFNER FN 1393-10-05-11 |
| SK2 | ACTUATIONS | BURNDY 8 pins male |
| SK3 | STATUS | BURNDY 19 pins female |
| SK4 | MEASURE | LEMO 00 coaxial female |
| SK5 | I _M MEAS. | LEMO 1 2 pins |
| SK6 | OUT REF. I _M | LEMO 2 2 pins |
| SK7 | I _M SOS | LEMO 0 2 pins |
| | E-GND | Banana terminal 4mm (black) |
| | M-GND | Banana terminal 4mm (green/yellow) |

Fig. 2 CERN Specific Computer Control Interface: General layout.

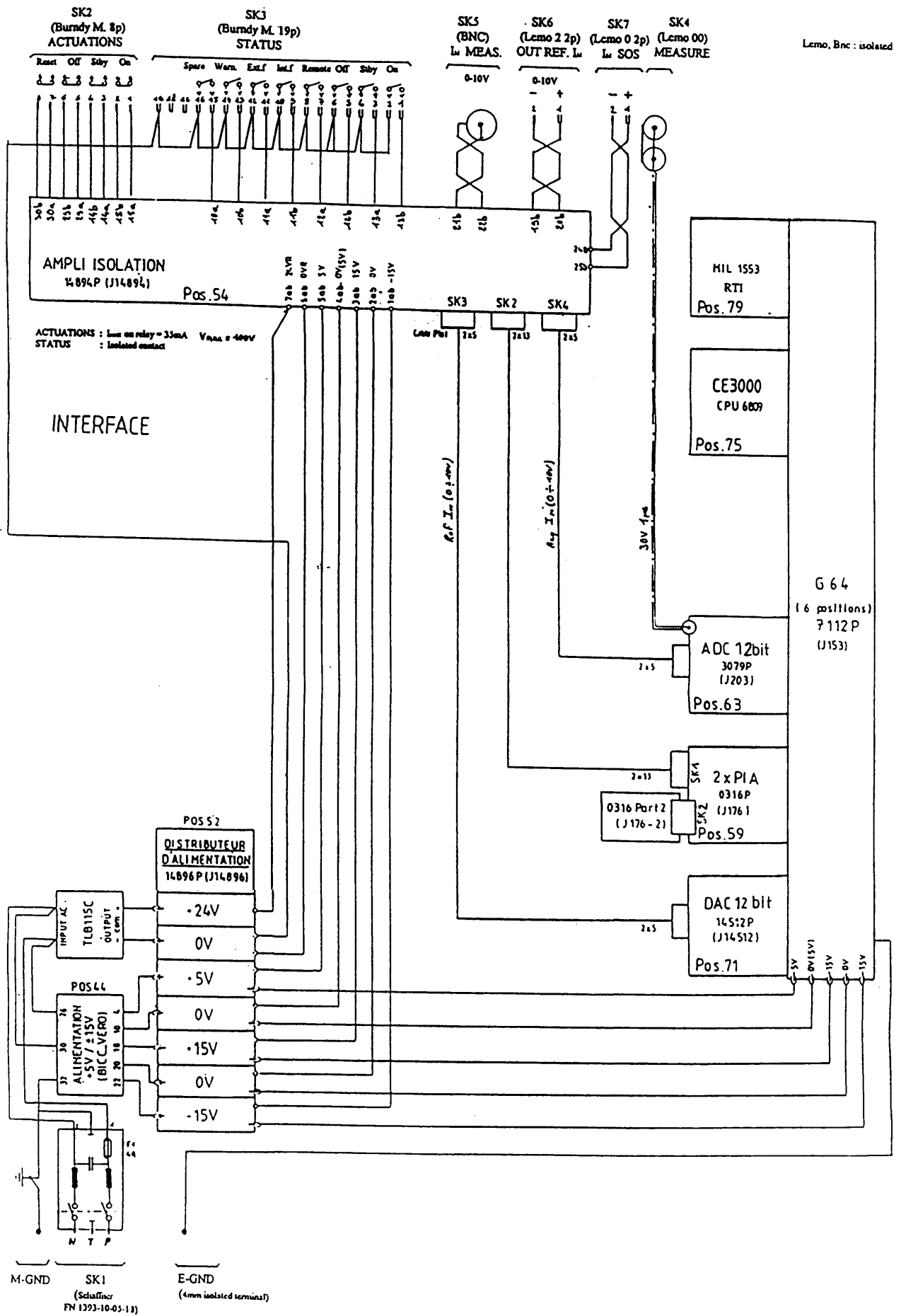

Fig. 3 CERN Specific Computer Control Interface: Cabling diagram.

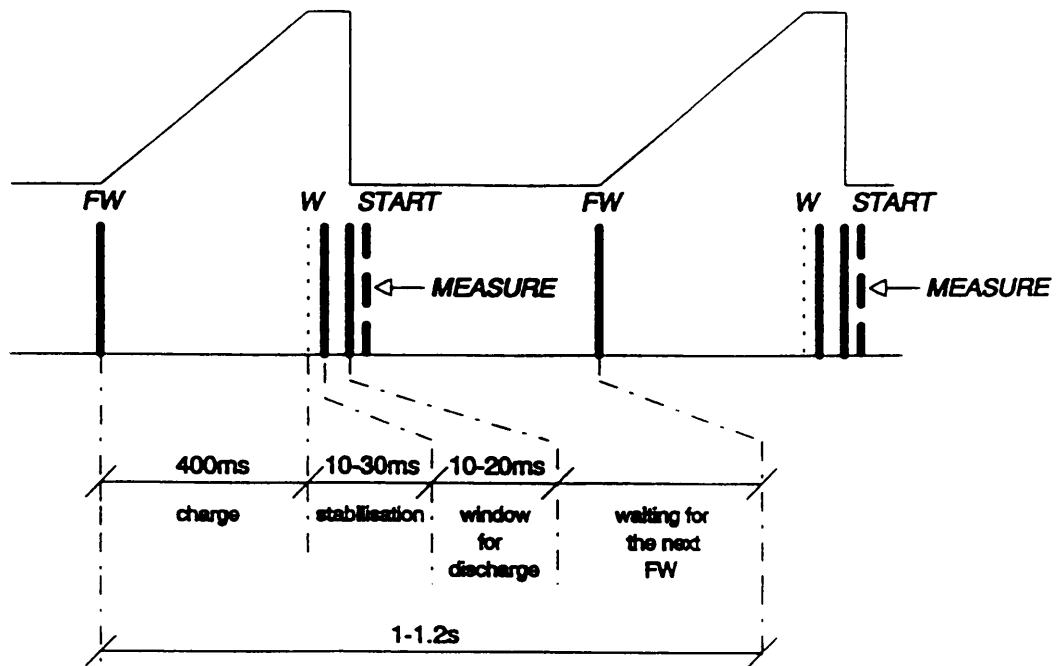

Fig. 5 Timing sequence and power converter duty cycle.

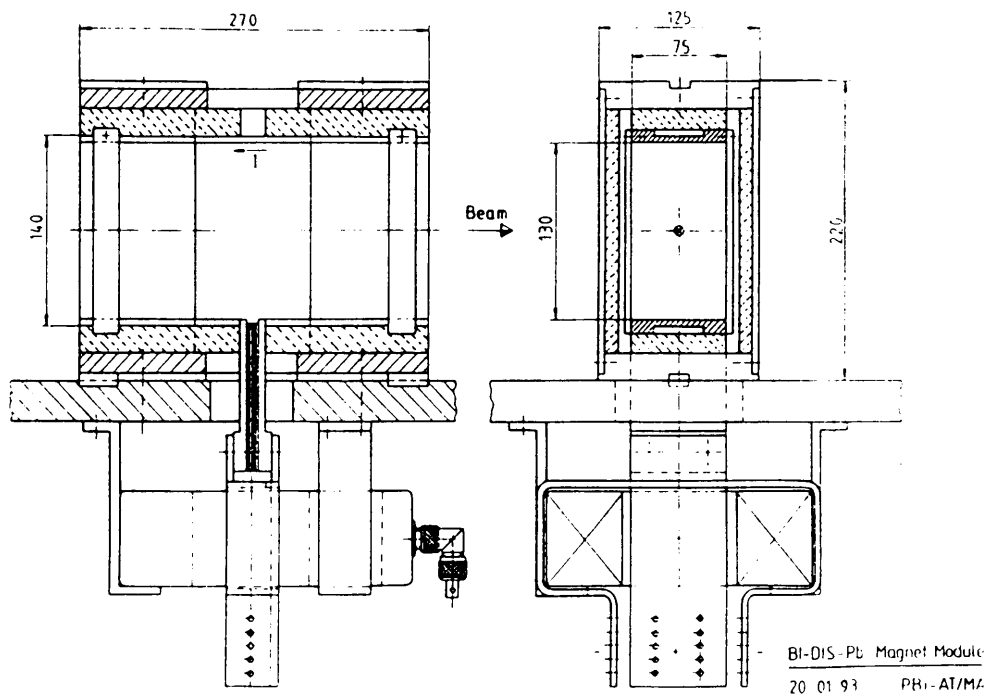

Fig. 6 BI-DIS-Pb prototype magnet module: Principle layout.

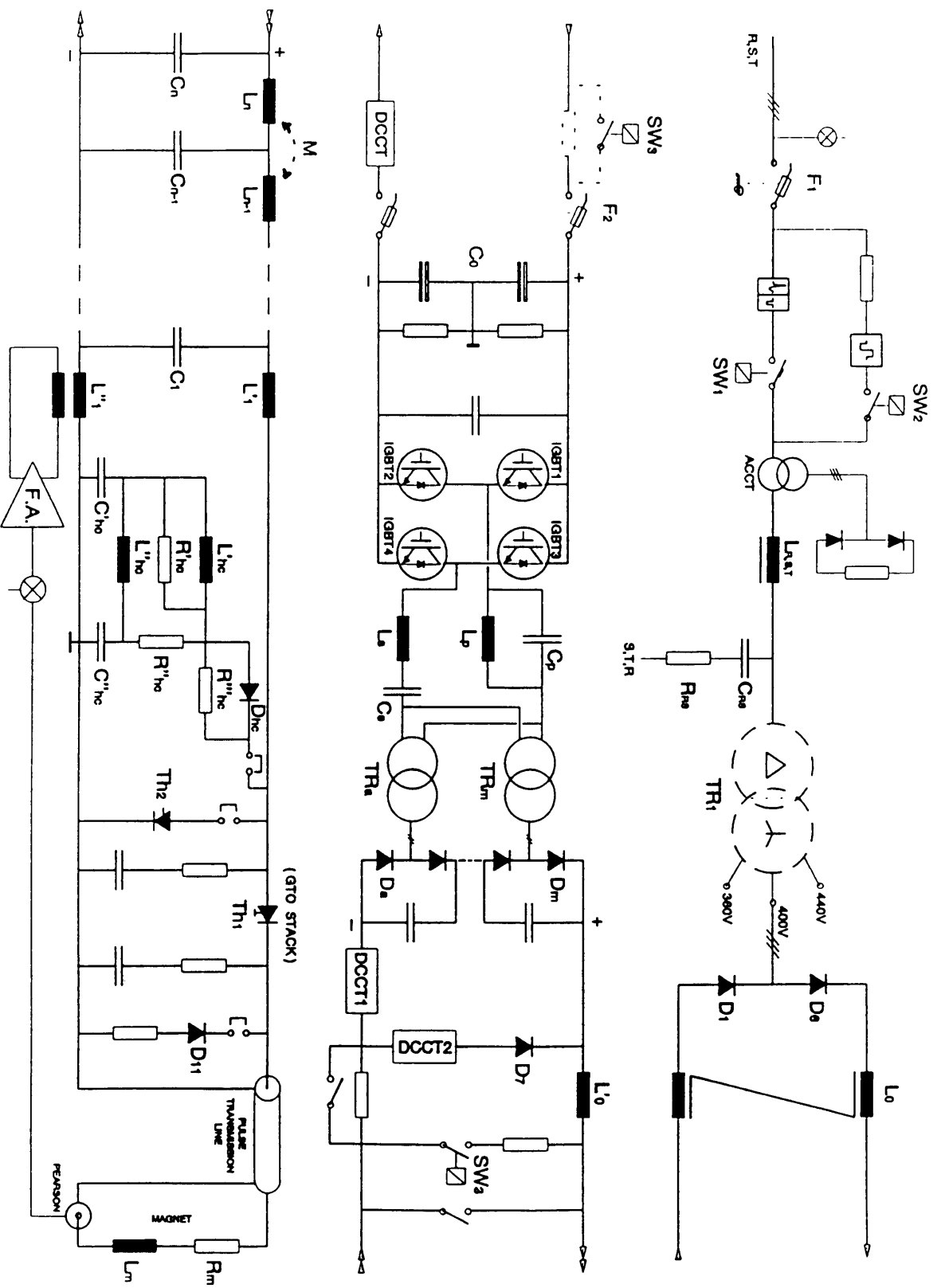

Fig. 7 Principle circuit diagram of prototype power converter.

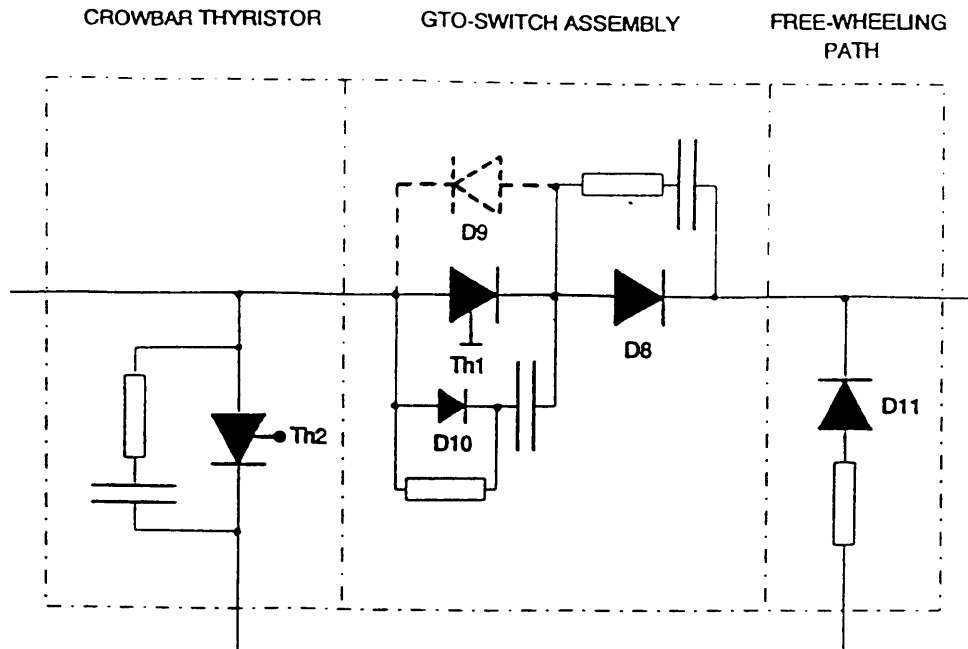

Fig. 8 Prototype Switch assembly: Principle diagram.

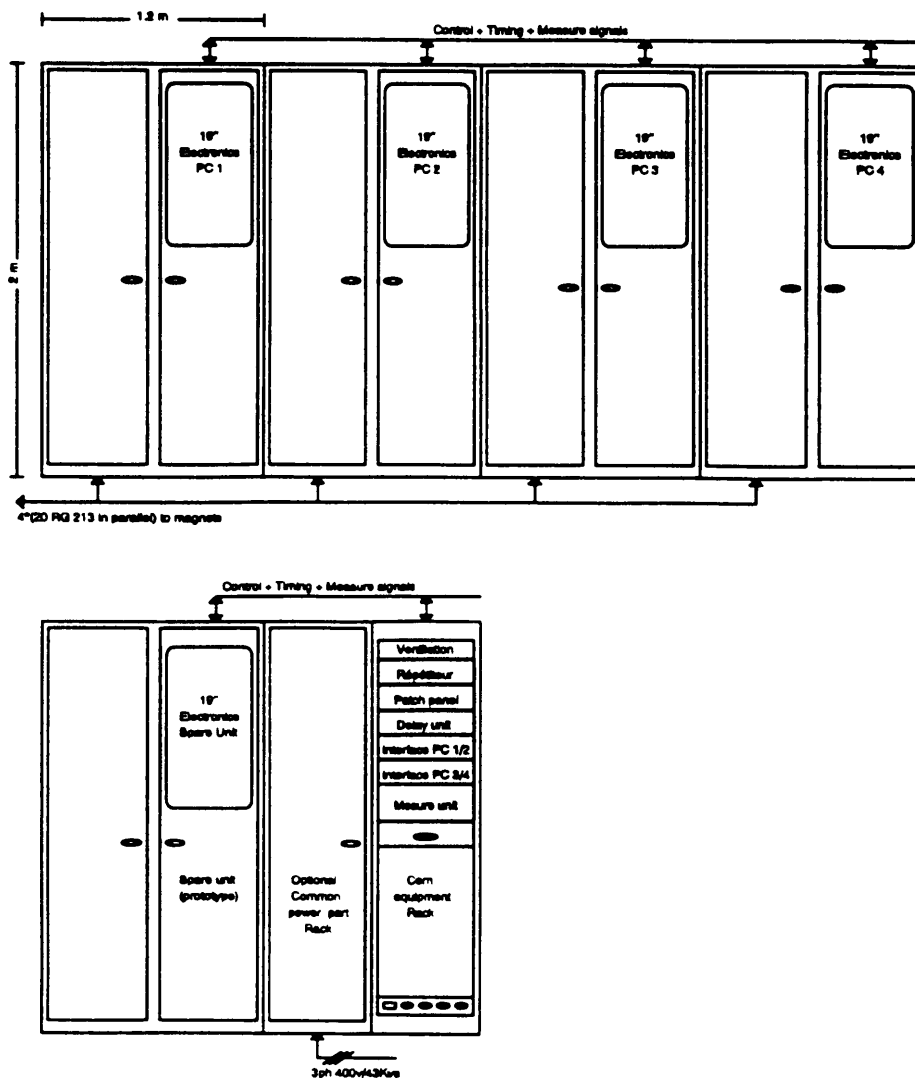

Fig. 9 General layout of power converter installation.