

## Photocathode lab optical system SC Hutchins

### Aims- types of measurements

To test and characterise photocathodes effectively requires that measurements be made over a long term to determine the lifetime, at different energy densities to explore non-linear effects and at several wavelengths to determine the optimum operating point. Given the lasers available, the function of the "beam lines" is to facilitate as far as possible these measurements.

### photocathode lab

The arrangement of the photocathode lab is as shown schematically, there are four beam lines, one for each harmonic range ( the fundamental wavelength is not used), these are arranged to be parallel on the table, the last mirror in the line for each harmonic is aligned away from parallel so that the beams converge at the cathode. The two lasers each produce their outputs simultaneously, this is not the ideal situation, as to produce the higher harmonics, the lower ones are absorbed and converted. There are two arrangements of conversions, the first gives the fundamental, second, fourth and fifth harmonics, the second gives the fundamental, second and third harmonics. In both arrangements the second harmonic is created from the fundamental, then the third may be produced by addition of the fundamental and second harmonic, or the fourth by doubling the second harmonic, and finally the fifth is an addition of the fourth and fundamental. To change from one arrangement to the other takes only a few seconds, but 5 to 10 minutes may be required to achieve the required temperature stability. As the conversion processes have low efficiency this arrangement does not give a limit to the photocathode investigations, the residual light available must still be attenuated on all but the lowest efficiency cathodes.

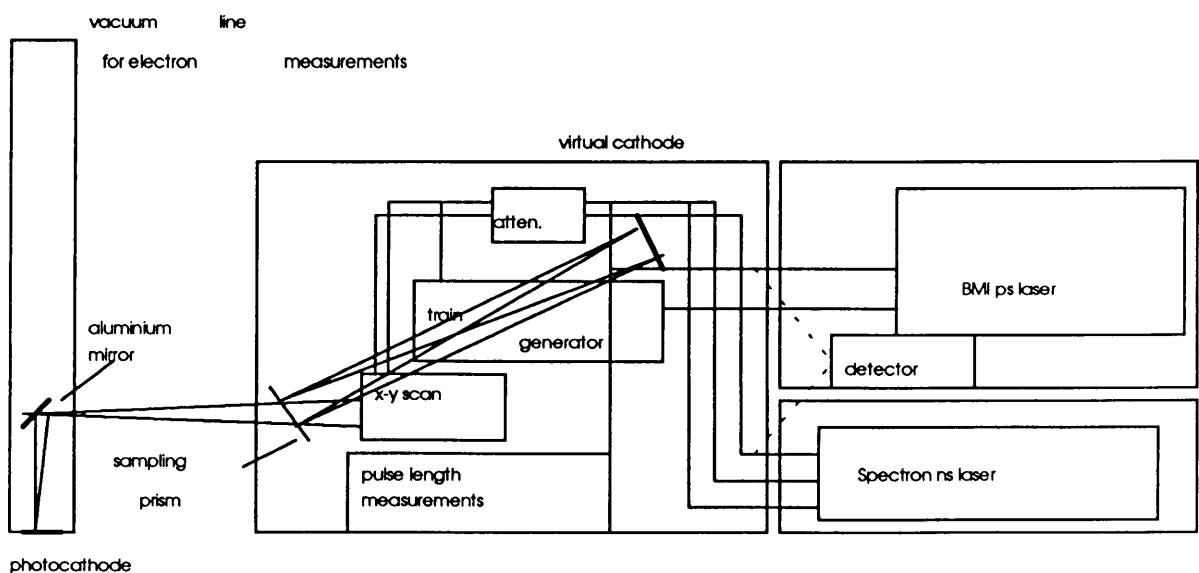

As all the beams are focused and aligned onto the photocathode, it is possible to change between wavelengths easily by changing the positions of absorbing blocks. This is an important feature of the photocathode work permitting the rapid characterisation

of the cathodes with wavelength. A train generator is foreseen to facilitate measurements on the electron bunches when the ps laser is used. The x-y scan permits the emission profile of the photocathode to be determined, this is also used to centre the laser spot on the cathode. The sampling plate sends a portion of the energy to two measuring points on the virtual cathode, these show the beam position and form, one test which is made is to vary the focusing of the beam for a given energy, with the virtual cathode it is possible to monitor the beam size and energy distribution. A detector is included in the system which may be triggered by the light from either laser, this provides a trigger for the measurements as neither laser is synchronised.

## The Lasers

Both of the lasers used are "flashlamp pumped solid-state", the laser medium is solid-state, Nd:YAG<sup>1</sup> in the case of the Spectron ns laser. The population inversion of excited states in the laser medium is provided by optical pumping from flashlamps. Only a narrow range of wavelengths from the flashlamps can be usefully absorbed in the laser medium, the rest is converted to heat which must be extracted, hence both lasers have closed circuit deionised water cooling systems.

### The nanosecond laser, Nd:YAG

|                 |              |              |              |             |
|-----------------|--------------|--------------|--------------|-------------|
| wavelength      | 534 nm (2nd) | 355 nm (3rd) | 266 nm (4th) | 213nm (5th) |
| energy (max.)   | 16 mJ        | 5 mJ         | 4.8 mJ       | 0.8 mJ      |
| energy (normal) | 10 mJ        | 3 mJ         | 1.5 mJ       | 0.2 mJ      |
| rep. rate       | 10 Hz        |              |              |             |
| pulse length    | 7 nS         |              |              |             |

The material is a crystal doped with Neodymium, which replaces 1% of the host Yttrium. The advantages of Nd:YAG as a laser medium are that it is relatively efficient, it is a robust material and is relatively easily made. It is one of the standard laser materials, used industrially for the cutting, welding and marking of metals. It is not possible to produce pulses shorter than ~35 ps, as the bandwidth is too narrow. In the cavity of the Spectron laser, the polariser<sup>2</sup> and Pockles' cell favour the transmission, and therefore amplification, of horizontally polarised light. The Pockels cell rotates the polarisation by 90° when a high voltage signal is applied. The output mirror is polarisation sensitive, vertically polarised light is transmitted, horizontally polarised light is reflected back into the cavity. When the Pockels' cell is switched, all the light passing in the direction of the output mirror is rotated to a vertical polarisation and 'dumped' out of the cavity. The pulse length is twice the cavity length, about 7 ns. As the operation of this laser is completely passive, a T<sub>em</sub>00 output beam with single longitudinal mode would have Gaussian transversal and temporal profiles, but in order to extract a maximum of energy the laser is run "multimode", the limiting aperture in the cavity is enlarged, and many horizontal modes are superimposed, the resulting transversal profiles are arbitrary. To have a single longitudinal mode would require that the laser be "seeded" with a small initial pulse, which would then be

<sup>1</sup>YAG, Yttrium Aluminium Garnet, Y<sub>3</sub>Al<sub>5</sub>O<sub>12</sub>; 1064nm

<sup>2</sup>The polariser may be a plate aligned at the Bragg angle to have no reflection for horizontally polarised light, but a significant loss is introduced in the vertical polarisation. Successive passes of light in the cavity are preferentially amplified or attenuated according to their polarisation.

amplified, as this is not the case there are many longitudinal modes, the resulting temporal profile consists of many modes superimposed.

Key for laser drawings:

- |   |                                  |   |   |
|---|----------------------------------|---|---|
| a | Cavity mirrors                   | j | 262 nm , 4 th harmonic (or 349 nm 3 rd harmonic) generator        |
| b | saturable absorber cell          | k | 209 nm (5 th harmonic) generator                                  |
| c | acousto-optic modulator          | l | UV mirror   |
| d | Nd:YLF bar in flashlamp housing  | m | UV prism (separates 4 th and 5 th harmonics)                      |
| e | single pulse selector            | n | Dichroic mirror (separates 3 rd or 4 th from shorter wavelengths) |
| f | amplifier (Nd :YLF + flashlamp)  | o | Dichroic mirror (separates 2 nd from shorter wavelengths)         |
| g | IR detector                      | p | 1047 nm beam dump   |
| i | 524 nm (2 nd harmonic) generator | q | pockels cell, Q-switch  |

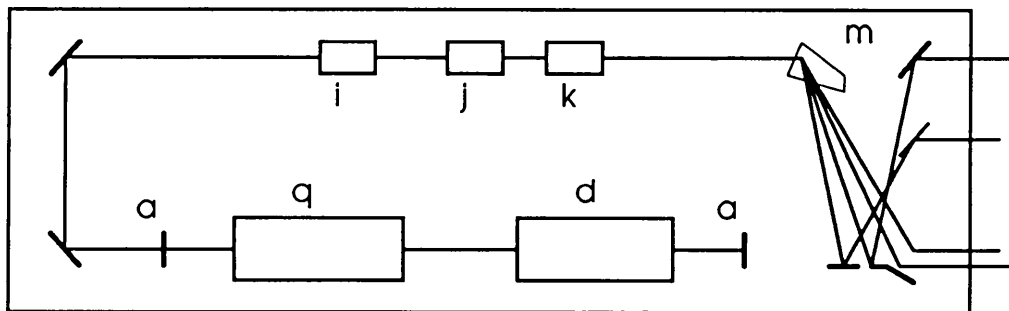
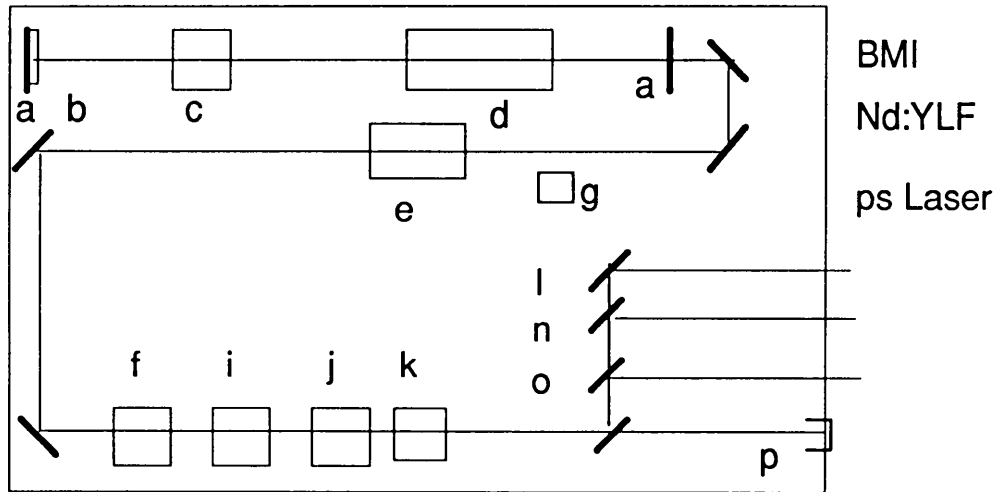

Spectron Nd:YAG ns laser

**The picosecond laser, Nd:YLF**

| wavelength      | 524 nm (2nd) | 349 nm (3rd) | 262 nm (4th) | 209 nm (5th) |
|-----------------|--------------|--------------|--------------|--------------|
| Energy (max)    | 5 mJ         | 2.0 mJ       | 1.4 mJ       | 0.2 mJ       |
| Energy (normal) | 5 mJ         | 1.6 mJ       | 1.2 mJ       | 0.2 mJ       |
| Rep.rate        | 10 Hz        |              |              |              |
| Pulse length    | 25 ps        |              | 12 ps        |              |

In the BMI laser Nd:YLF<sup>3</sup> is used as the laser medium, it has higher bandwidth than Nd:YAG but has poorer thermal conductivity, increased fragility and lower gain per pass in the cavity, it is less efficient but can produce pulses of less than 5 ps.

In the ps laser an absorbing dye and an acousto-optic (A-O) modulator have been added in the cavity. The A-O modulator changes the polarisation in function of an applied sine wave, the frequency of which must match the cavity length, in this case about 80MHz. The effect of this is to only permit propagation in the cavity during a limited phase range, a pulse will be created which is much shorter than the cavity length, about 100 ps, depending on the amplitude of the applied signal.

The further addition of a saturable absorber reduces this pulse to the 25 ps required, the absorber being a dye which is initially opaque to the laser light, but which, after a certain amount of light has been absorbed, saturates and becomes transparent. Thus the leading edge of the laser pulse is progressively absorbed, shortening the pulse at each passage in the cavity. The output mirror is partially transmitting, a fraction of the pulse in the cavity is extracted at each round-trip in the cavity. The oscillator therefore produces a train of 8 to 15 pulses (depending on the dye condition) at a separation of 8ns when the flashlamps are fired, each pulse represents a successive round-trip in the cavity. The highest amplitude pulses are near the centre of the pulse train.

The train of pulses is blocked by the pulse selector, which is a Pockels' cell between crossed polarisers, light can only be transmitted during the time that a high voltage signal is applied to the cell. This is used to select one pulse from the train to be amplified, the optimum operating point is just before the highest pulse of the train, the pulse selector detects the amplitude of the pulses, the required pulse is chosen from the train in function of this, the pulses' position in the train may vary to compensate for amplitude differences from shot to shot. As the operation of the laser depends on factors such as dye concentration and ageing of both the dye and flashlamps, the working point would vary so the intensity of the oscillators' flashlamps is adjusted to compensate. The selected pulse is then passes through an amplifier, the flashlamp energy of which is independently varied depending on the energy required.

The bandwidth of the active material and the dye is greater than that required for a 25ps pulse, it cannot therefore be expected that the output will have a simple Gaussian temporal shape. The effect of the bleaching dye is to create a steep leading edge, the resulting pulse will have an inclined triangular form. After passage through the different harmonic generators, which are non-linear linear crystals, the form may resemble a steep leading edge followed by an exponential decay, the pulse width is also reduced. The pulse shape must be determined before measurements by auto correlation can be interpreted<sup>4</sup>.

### harmonic generation

The fundamental wavelengths for Nd:YAG and Nd:YLF are 1064 and 1047 nm, shorter wavelengths are created by passage through non-linear optical crystals, which can create a second beam at half the wavelength of that applied. Some typical efficiencies are listed for three common materials, better results have been achieved in special systems having peak energy of GW. These figures depend on many factors,

---

<sup>3</sup>YLF, Yttrium Lanthanum Fluoride, YLiF<sub>4</sub> ;1047nm

<sup>4</sup>The standard measurement of FWHM is inadequate for asymmetric forms, for a given pulse width the peak energy will be higher than with a gaussian pulse. see P.Joly, "Pulse duration measurement" PS/LP/93-28.

such as the power of the laser, its beam quality and energy, as well as certain characteristics of the crystals, such as the physical size they can be made, their absorption of the generated light and damage thresholds.

|      | Second Harmonic<br>Generation | Fourth H. G.<br>(from 2nd ) | Fifth H.G.<br>(from 4th +1st) |
|------|-------------------------------|-----------------------------|-------------------------------|
| KTP* | 60%                           | 40%                         | 0                             |
| KDP  | 50%                           | 35%                         | 0                             |
| BBO  | 60%                           | 40%                         | 20%                           |

The crystals must be accurately oriented with respect to the beam and temperature compensated, if stable and efficient conversion is to be achieved. The low efficiencies of these conversions when optimised in a chain results in very little energy at the higher harmonics and as a consequence of the non-linear action, any amplitude variations at the fundamental wavelength are exaggerated at the higher harmonics.

### polarisation: mirrors, metal and multi-layered

As the lasers produce light at several wavelengths, visible to ultra-violet, the mirrors which transmit this light should be chosen to minimise losses in the path. Two types of

|           | absorption, 250 nm | absorption, 1060 nm |
|-----------|--------------------|---------------------|
| Aluminium | 18%                | 10%                 |
| Copper    | 70%                | 8%                  |
| Silver    | 77%                | 3%                  |

mirror are available, metallic surfaced and multi-layered. For low intensity beams of visible light the former are often chosen, for high power and pulsed lasers their losses are significant and they may become damaged by the absorption of the incident energy<sup>5</sup>. For this reason multi-layered dielectric coatings are the only solution, however these have a limited bandwidth, as each layer must be 1/4 or 1/2 of the wavelength of the incident light. The bandwidth of a mirror stack is sufficient to cover the slight differences of wavelength for the same harmonics of the two materials used in the lasers (Nd:YAG and Nd:YLF), but not to cover more than one harmonic, so the four harmonics must be treated separately. Other problems with this type of mirror are the absorption losses in the UV and the tolerances required for good mirrors. The layers in a stack have alternate high and low refractive indexes, so that reflections from each layer add up in phase<sup>6</sup>. The difference between the two refractive indexes (proportional to density) used determines the percentage reflection from each layer, most materials available absorb in the UV region, this limits the flexibility available to the mirror designer, who is forced to use more layers, and/or less stable materials. A mirror stack may consist of over 20 layers, each reflecting a small percentage of the incident light, this is further aggravated when both horizontal and vertical deflections are required of polarised light. When the plane of polarisation is across the plane of incidence (s polarised<sup>7</sup>) light is easily reflected from each surface, conversely when the plane of incidence and the plane of polarisation are parallel (p polarised) very little light is reflected. It may be seen that the reflectivity of a mirror will depend on the

<sup>5</sup>Photonics Handbook, p210

<sup>6</sup>From this it may be seen that short pulses will be stretched by passage "through" or off of such a mirror, an important problem in the femtoscond regime, which we are fortunately spared.

<sup>7</sup>s for *senkrecht*, German for perpendicular, referring to the planes of incidence and polarisation

polarisation of the incident light, many more layers will be required for a p polarised mirror.

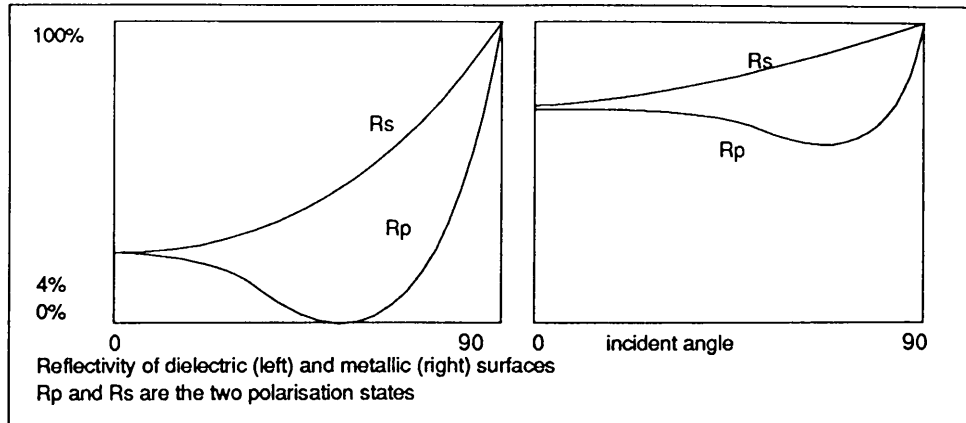

| Dielectric material            | Density | Comment                 |
|--------------------------------|---------|-------------------------|
| CaF <sub>2</sub>               | 3       | Hygroscopic             |
| SiO <sub>2</sub>               | 2.1     | Lossy, fast evaporation |
| MgF <sub>2</sub>               | 3.1     | Hygroscopic             |
| HfO <sub>2</sub>               | 9.7     | Low damage threshold    |
| Sc <sub>2</sub> O <sub>3</sub> | 3.8     | 2700K evaporation       |
| Al <sub>2</sub> O <sub>3</sub> | 3.6     | 2400K evaporation       |

Electron beam deposition is used for the high temperature evaporation. Fast evaporation implies less control of the layer thickness<sup>8</sup>. Hygroscopic materials give mirror properties that will change with time.

There are two types of monitoring system to directly control the thickness when manufacturing multi layer mirrors. One is the quartz crystal method, as used in the photo cathode lab, where the resonant frequency of a crystal which is placed near to the substrates is monitored. As material is deposited in the chamber, the extra mass on the quartz causes a change in its resonant frequency. The other method is direct optical measurement of the mirrors' reflectivity during evaporation. Many manufacturers use neither method, relying instead on accurate timing of the deposition process, the rates of deposition having been previously calibrated.

There are several supplementary problems in the UV ( $\lambda=209$  nm) region, the first is that the coatings must be about 1/3 of the thickness of those in the visible region ( $\lambda=550$  nm) and the tolerance is 3 times higher. At the required thicknesses the optical changes measured with visible light are very slight, as the wavelength difference is only  $\lambda/12$ , no manufacturers are equipped to optically monitor with UV light, so that either the crystal method or direct process timing must be used. As the coatings are thinner these methods also loose precision. It may be appreciated therefore, that while mirrors are available in the visible region with reflectivities of over 99.5%, this will not be the case at 209 nm.

An unresolved problem is the metal mirror presently placed in the vacuum chamber, for picosecond work at 349 nm or 524 nm, this mirror will limit the energy available on the cathode, an alternative 4-mirror solution may be required if high laser powers are required at the cathode, e.g. metallic cathode tests.

<sup>8</sup>The HR mirrors used in the photocathode lab and the CTF are HfO<sub>2</sub>/SiO<sub>2</sub> stacks, (Tec Optic)

## energy variation and measurement

To identify non-linear effects in the photocathode response, measurements are required over several orders of magnitude, given the limitations of the lasers the following ranges would be required.

| wavelength | pulse length | maximum energy | minimum energy |
|------------|--------------|----------------|----------------|
| 209 nm     | 25 ps        | 100 $\mu$ J    | 1 nJ           |
| 262 nm     | 25 ps        | 400 $\mu$ J    | 1 nJ           |
| 349 nm     | 25 ps        | 1 mJ           | 10 nJ          |
| 524 nm     | 25 ps        | 3 mJ           | 10 nJ          |
| 213 nm     | 6 ns         | 150 $\mu$ J    | 1 nJ           |
| 266 nm     | 6 ns         | 500 $\mu$ J    | 1 nJ           |
| 354 nm     | 6 ns         | 2 mJ           | 10 nJ          |
| 532 nm     | 6 ns         | 4 mJ           | 10 nJ          |

Pyro-electric effect joulemeters have an even response over the range of wavelengths, but are limited in sensitivity at about 0.5  $\mu$ J<sup>9</sup>. Silicon detectors<sup>10</sup> have a sensitivity limit of 20 pJ and a damage threshold of 1  $\mu$ J, they do not have a constant response, and do not work below 250 nm. By using cross calibrations, the range of interest may be covered.

There are various methods for attenuating a laser beam, by attenuation with calibrated semi-reflecting mirrors or by using the effect of polarisation. Metallic semi-reflecting mirrors are commonly used for low intensity applications, the technique has been extended to cover the range required by the use of multi-layer partially transmitting mirrors which have a higher damage threshold. Four sets of specially made mirrors are required, as the wavelength range of any particular mirror would only be 40 nm. The transmission of one mirror is 25-30%, they are designed to be used at 0° angle of incidence, so as to not cause deflection of the beam from its position on the cathode. Unwanted reflections must not perturb the energy measurements, which take place at a distance of 2m from the attenuators, this is ensured by the mechanical tolerances of the attenuator mounts. The mirrors are used in groups of 5, the maximum attenuation giving less than 0.3% of the incident energy.

## pulse length measurement

Among the fastest detectors commonly available there are vacuum diodes with risetimes of 100ps and semiconductor diodes at 500ps. These are adequate for measurements of nanosecond pulses as produced by the Spectron laser. To observe the signals special care must be taken to use suitable connectors and cables, an equally fast oscilloscope is also required.

Faster devices exist for light in the visible and infra-red regions, semiconductor bulk effect devices with rise times of as little as 6ps have been commercialised<sup>11</sup>. These convert the optical pulses to electrical ones, the problem becomes that of recording the pulse. At high repetition rates RF techniques may be used, for our application we are limited to 10Hz. A sampling oscilloscope<sup>12</sup> and fast detector combination will be used for monitoring the laser performance, but this arrangement is limited by its risetime and cannot follow the expected fast rising edge of the ps laser pulse and these detectors do not work at the wavelengths of interest in the UV.

<sup>9</sup>Laser Precision data, for RjP-735 detector. Flat response from 180nm to 3000nm.

<sup>10</sup>Laser Precision data, for RjP-765 detector with uv option. Limit is 300nm for normal detector.

<sup>11</sup>Nu Focus 1002 and 1011, bandwidths 45GHz and 60GHz

<sup>12</sup>Hewlet Packard 54123, bandwidth 50GHz.

Autocorrelation is possible using visible or green light, mixing in a non-linear crystal, as in the lasers' harmonic generators. For UV light, autocorrelation using either two-photon absorption in a gas or degenerate four-wave mixing in a crystal is possible. The temporal resolution can be better than a picosecond with these techniques, but interpretation of the autocorrelation result is difficult without knowing the form of the input pulse. These techniques will also be used in the photocathode lab.

### conclusion

The photocathode lab is a unique installation and is a necessary step in the CLIC project, which relies on it for the production of suitable photocathodes, for although they have been used for many years, there exists no immediate solution to the problems of efficiency, life-time, high intensity output and picosecond response. With the addition of the new picosecond laser and the vacuum transport system, many different cathode materials may be rapidly investigated, and if promising, be tested directly in the CTF.