

Determination of Collinear Proton Parton Distribution Functions using LHC Data

Paul Newman
(University of Birmingham)

on behalf of
the ATLAS, CMS &
LHCb collaborations

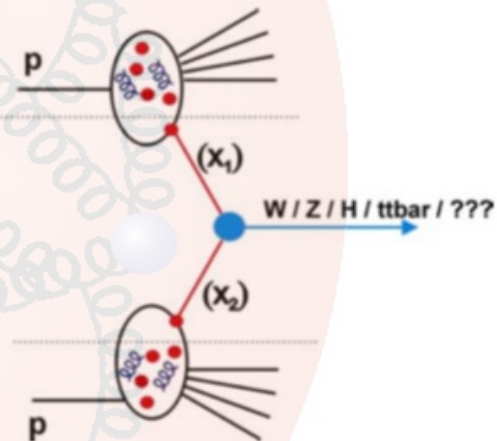

QCD@LHC2022

28 November 2022 to 2 December 2022
IJCLab Orsay, France

Proton PDF Pre-LHC Baseline: Final HERA Results (ep only: HERAPDF2.0)

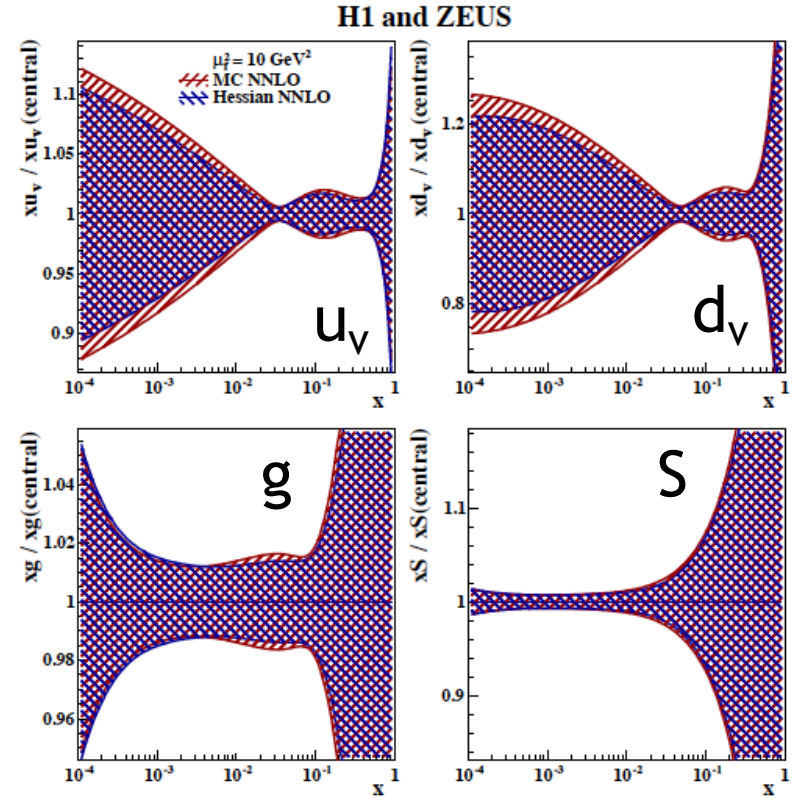
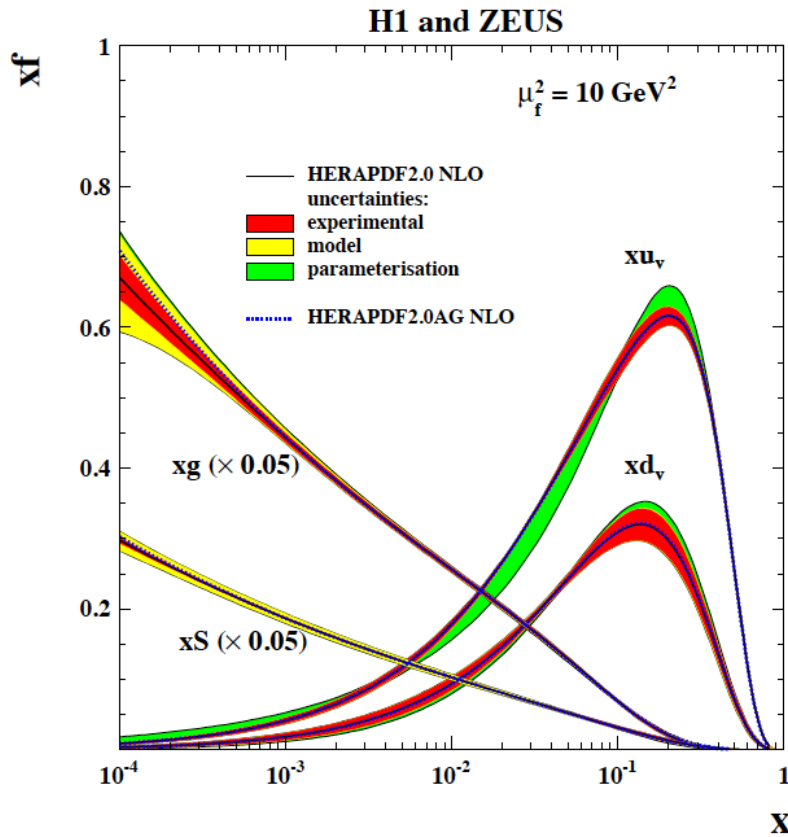

- ~2% gluon precision, 1% on sea quarks for $x \sim 10^{-2}$... BUT ...
- Low x gluon rising in non-sustainable way at large Q^2
- Uncertainties explode at largest x , where
HERA lacked precision

Constraining PDFs with LHC Data

- Many pp processes are sensitive to PDFs ...
- Electroweak gauge boson production
- Drell Yan (away from Z pole)
- High pT jet production
- Top Quarks
- Direct Photons
- Associated W+c, Z+c production

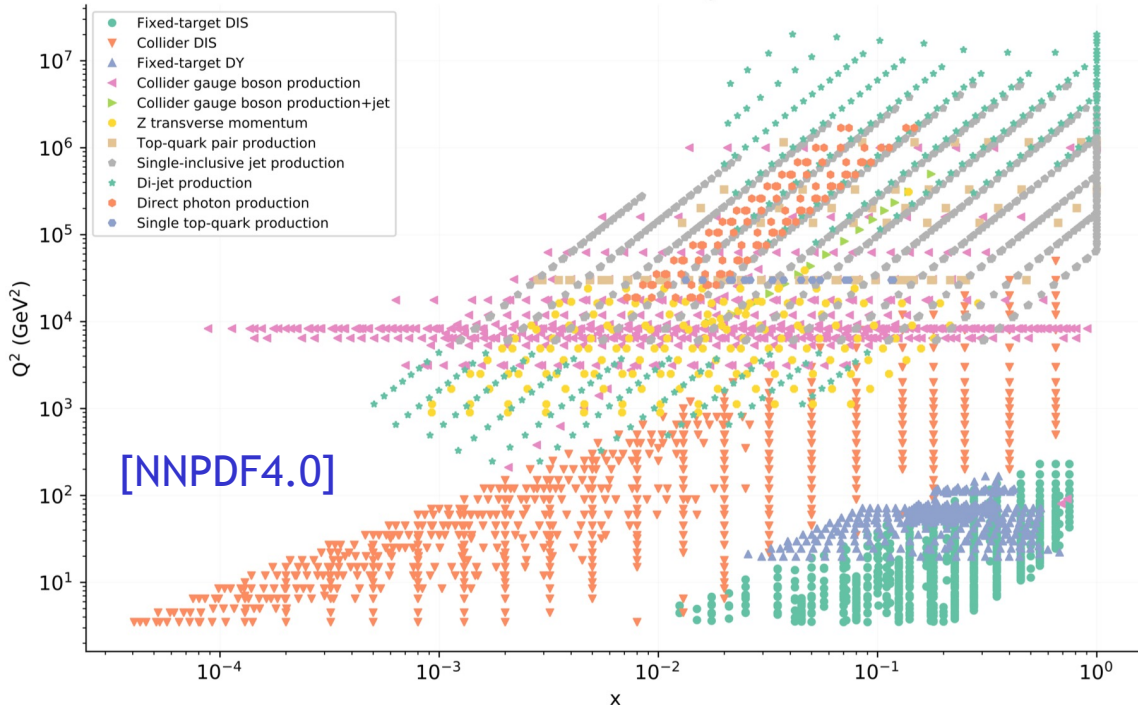
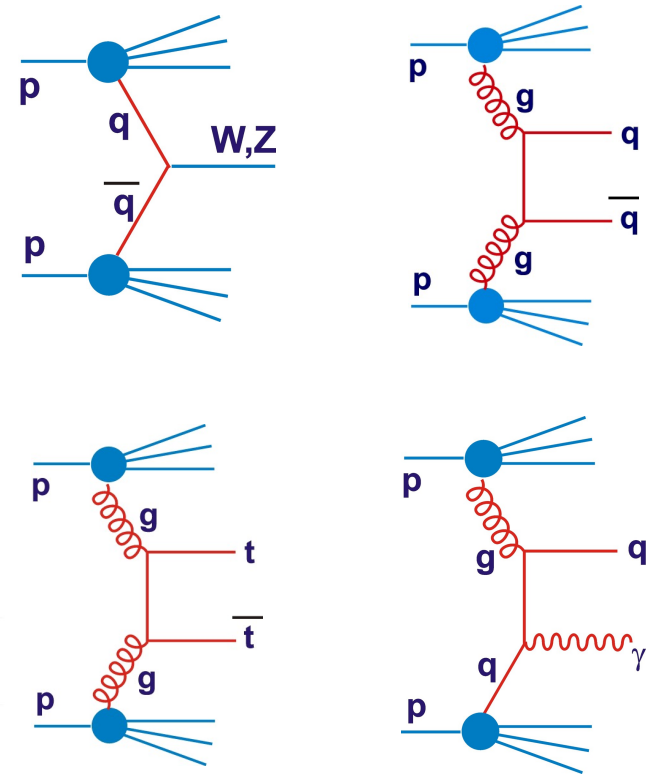

... programme to better constrain PDFs with LHC data both by experimental collaborations and by global fitting groups

Theory v Data at LHC

Standard Model Production Cross Section Measurements

Status: February 2022

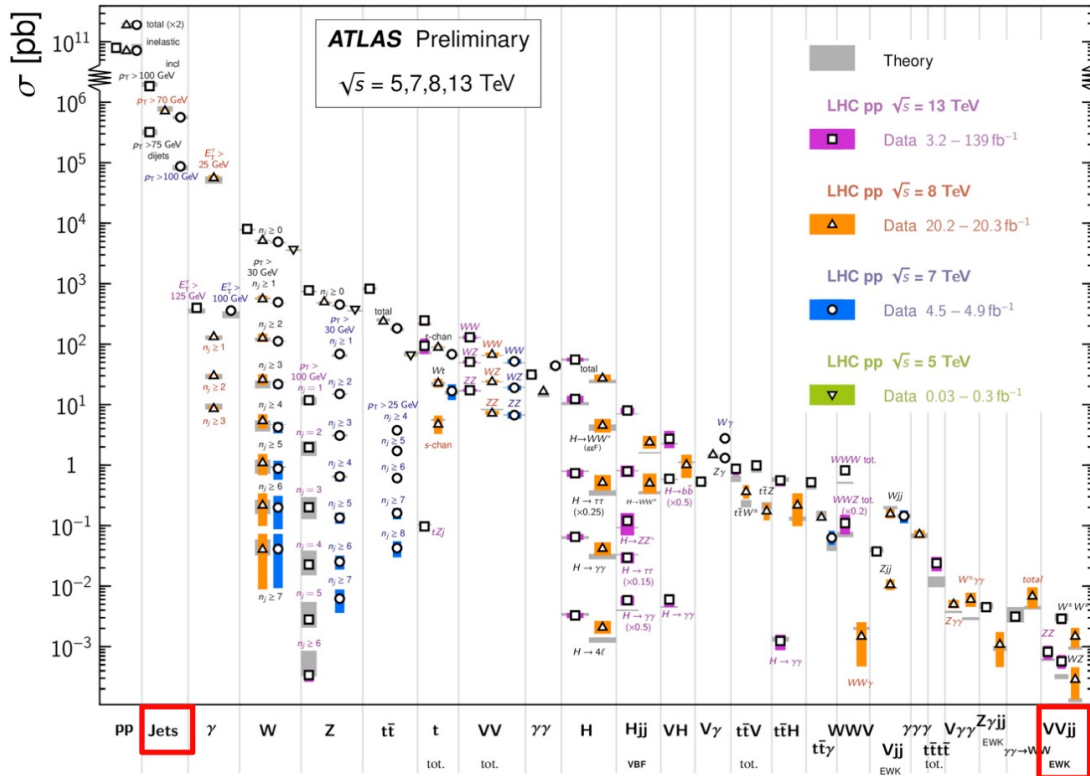

PDFs are a vital ingredient in almost all predictions

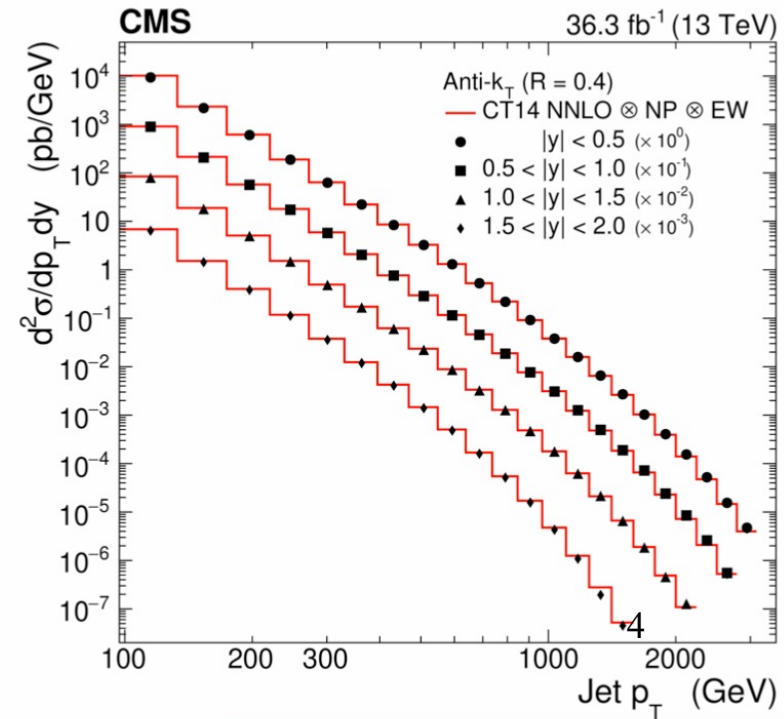

High x starting point: Inclusive jets:

- High rates, wide kinematic range
- ‘Astonishing’ agreement between data and (N)NLO QCD over many orders of magnitude in x-section, up to scales with $p_T \sim 2 \text{ TeV}$

Looking in more Detail ...

e.g. CMS inclusive jets ($R=0.4$) versus CT14 and others + non-pert, EW corrs

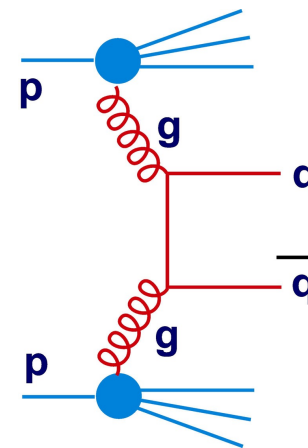
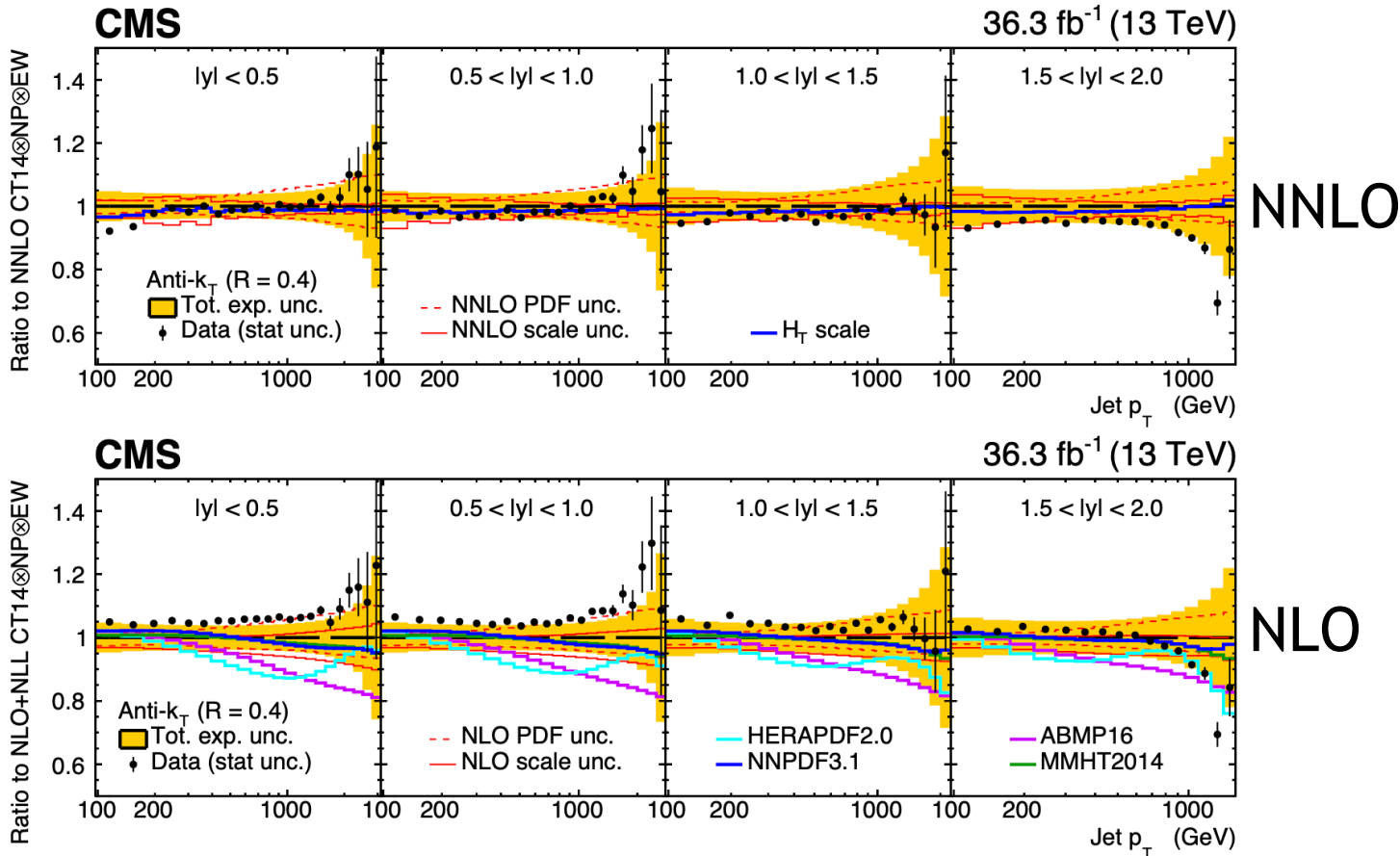

- Deviations at typically 5% level, worse at largest p_T
 → consistent with experiment + theory (including PDF!) systematics.
- What happens if you include the data in PDF fits?...

PDF Constraints from CMS QCD ANALYSIS

- Inclusive jets have substantial impact on gluon precision at all x relative to CT14 PDFs that already used previous LHC data.

- Singlet quark precision also improves

- Simultaneously, NNLO extraction of strong coupling ...

$$\alpha_s(m_Z) = 0.1188 \pm 0.0031$$

... uncertainty still dominated by scale uncertainty (0.0025)

- CMS 13 TeV Double-differential inclusive jets
- NC and CC cross sections from HERA

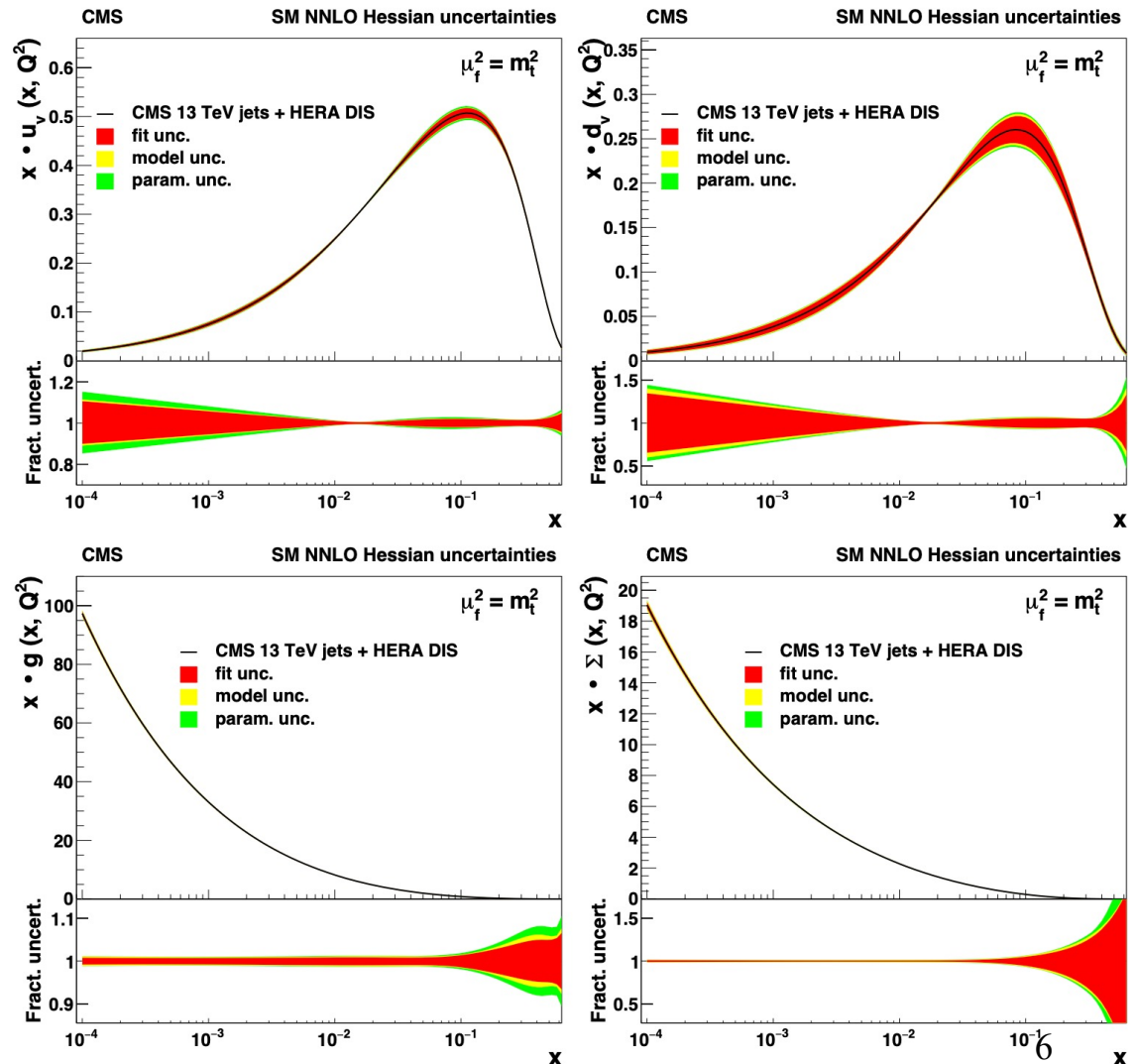

PDF Constraints from CMS QCD ANALYSIS

- Inclusive jets have substantial impact on gluon precision at all x relative to CT14 PDFs that already used previous LHC data.

- Singlet quark precision also improves

- Simultaneously, NNLO extraction of strong coupling ...

$$\alpha_s(m_Z) = 0.1188 \pm 0.0031$$

... uncertainty still dominated by scale uncertainty (0.0025)

- CMS 13 TeV Double-differential inclusive jets
- NC and CC cross sections from HERA

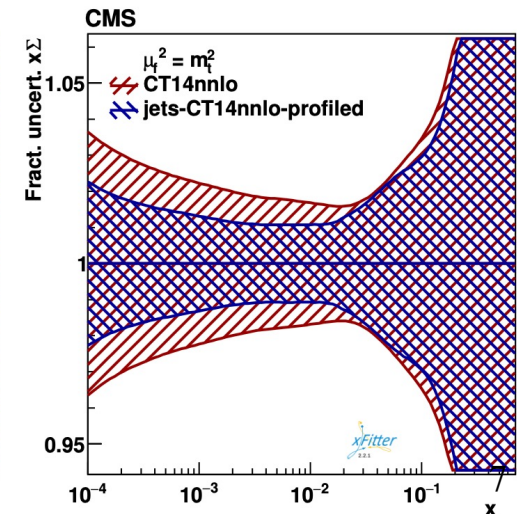
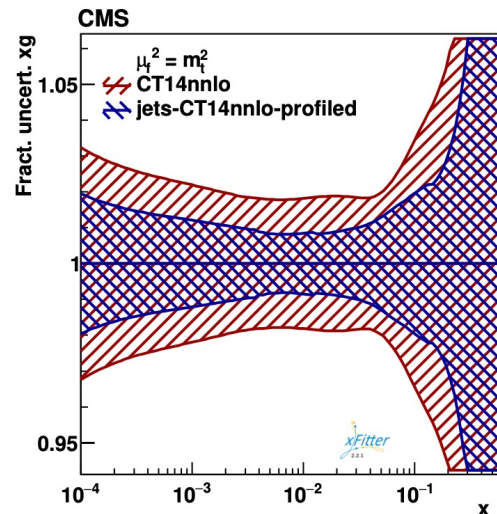
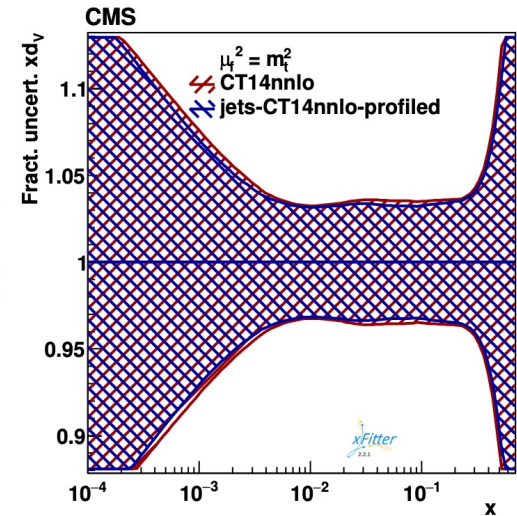
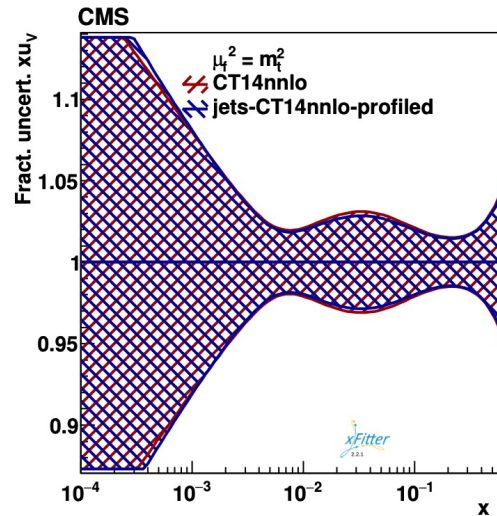

Data set	\sqrt{s} [TeV]	Luminosity [fb^{-1}]
Inclusive $W, Z/\gamma^*$ [9]	7	4.6
Inclusive Z/γ^* [13]	8	20.2
Inclusive W [12]	8	20.2
$W^\pm + \text{jets}$ [23]	8	20.2
$Z + \text{jets}$ [24]	8	20.2
$t\bar{t}$ [25, 26]	8	20.2
$t\bar{t}$ [15]	13	36
Inclusive isolated γ [14]	8, 13	20.2, 3.2
Inclusive jets [16–18]	7, 8, 13	4.5, 20.2, 3.2

Detailed study of correlations between uncertainties in different data sets and of different χ^2 tolerances

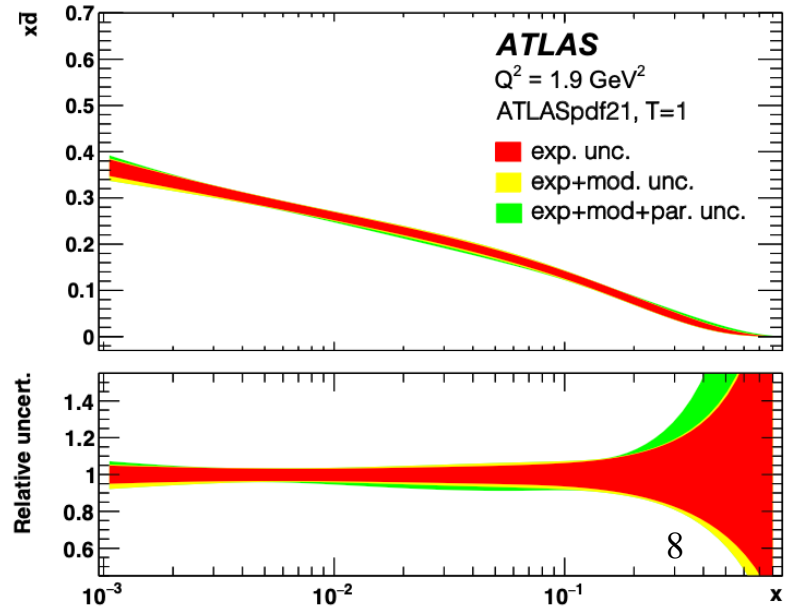
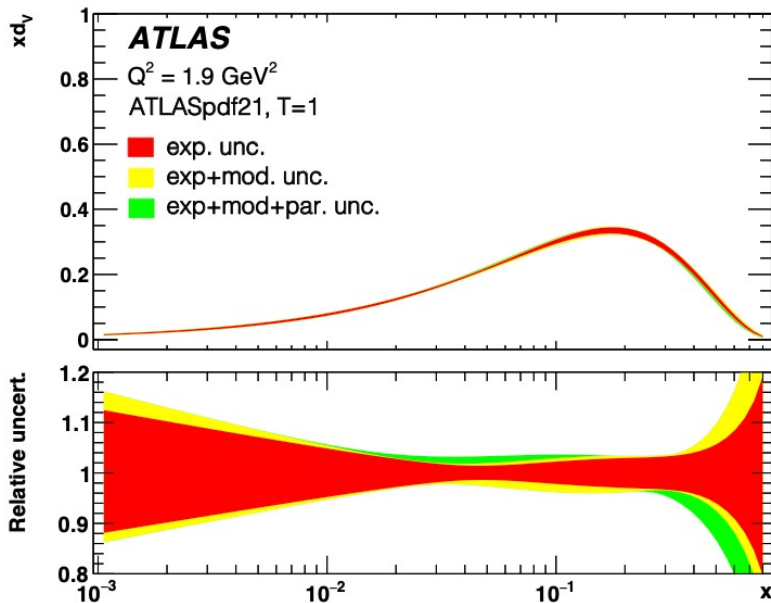
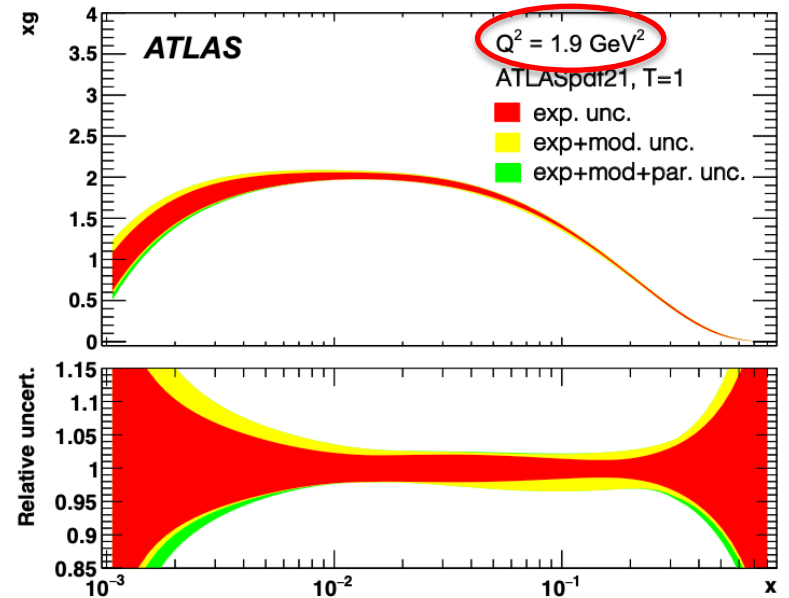

Impact of Different Data Sets

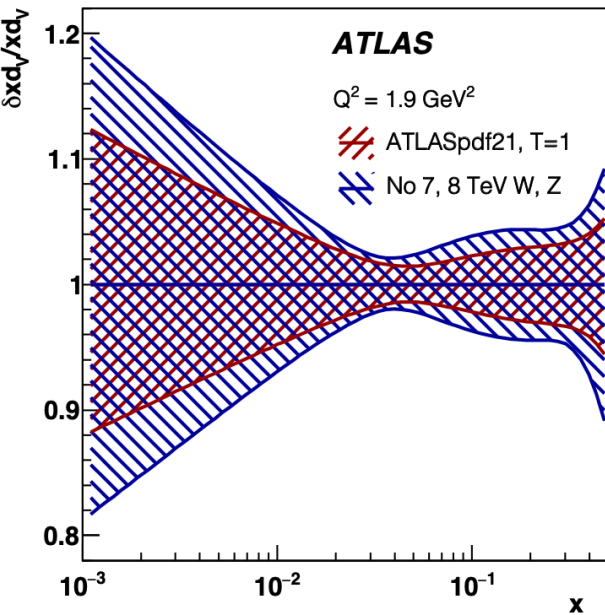

- W and Z data strongly constrain quark densities (and also gluon)
- Jet data primarily reduce gluon uncertainty at large x
- Top data also have an influence and soften high x gluon (mild tension with jets)

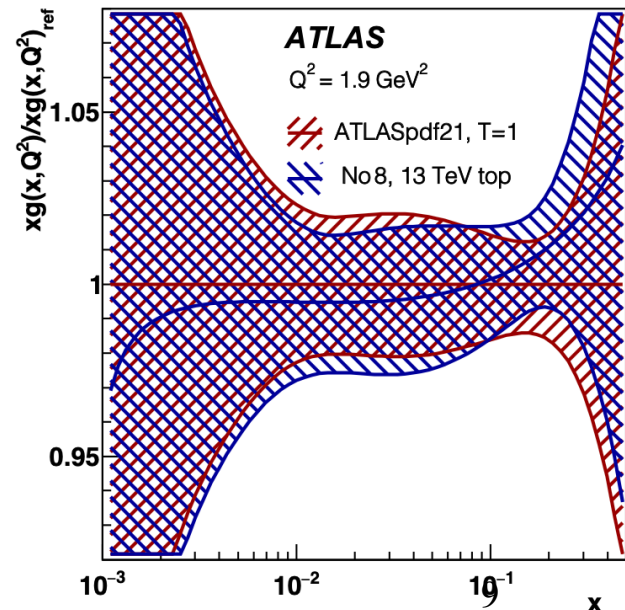
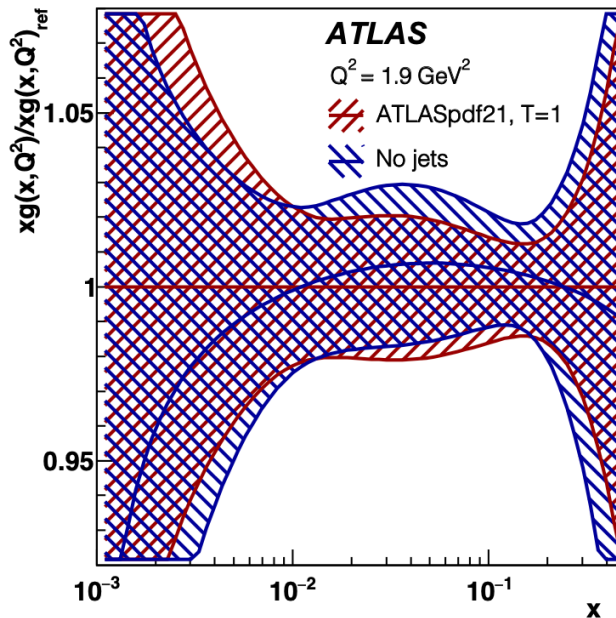
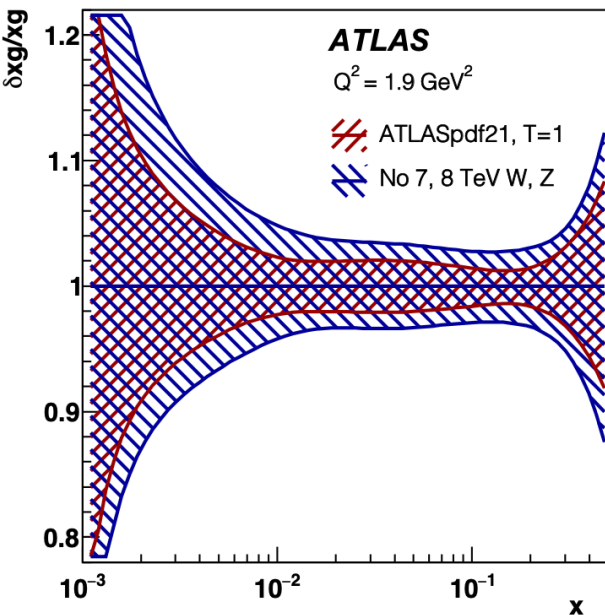

Further Constraints: Strangeness Fraction

$$R_s = x(s + \bar{s}) / x(\bar{u} + \bar{d})$$

- ATLAS fits constrain strange quark density mainly through inclusive W, Z
- Suggests a small strangeness suppression relative to u,d sea at low x. ... compatible with other (global) analyses

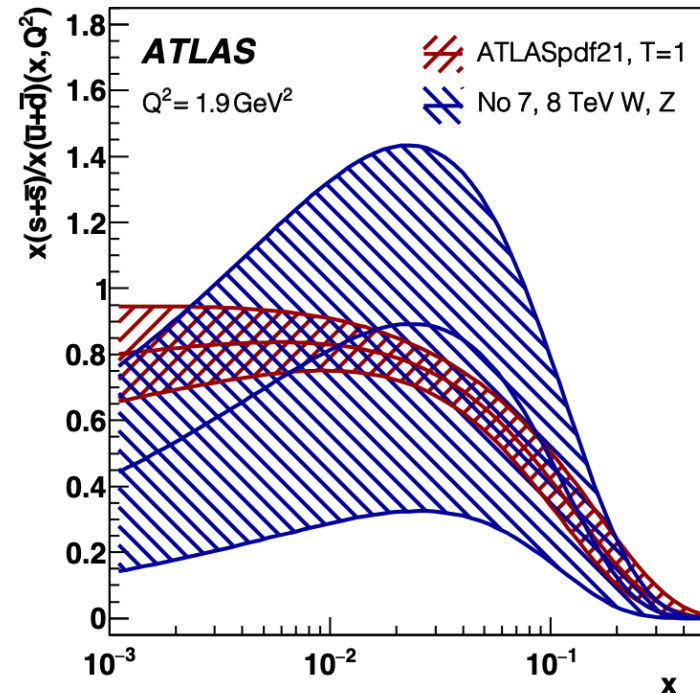
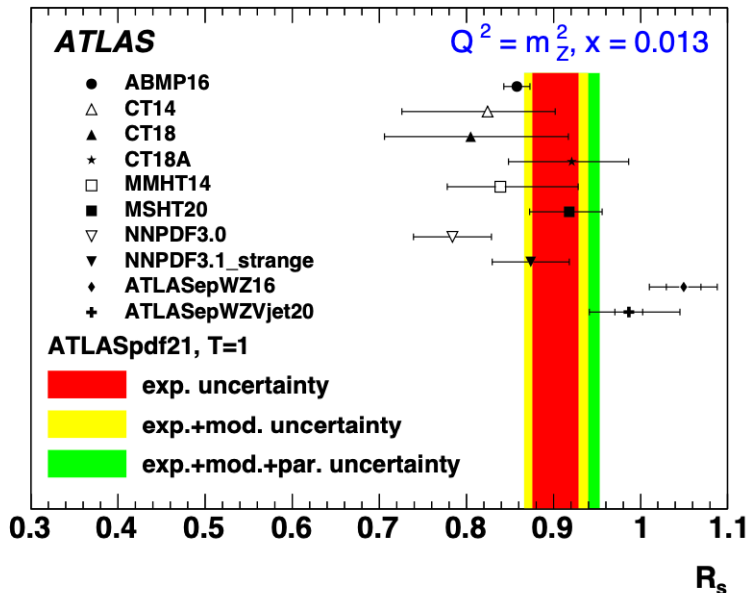
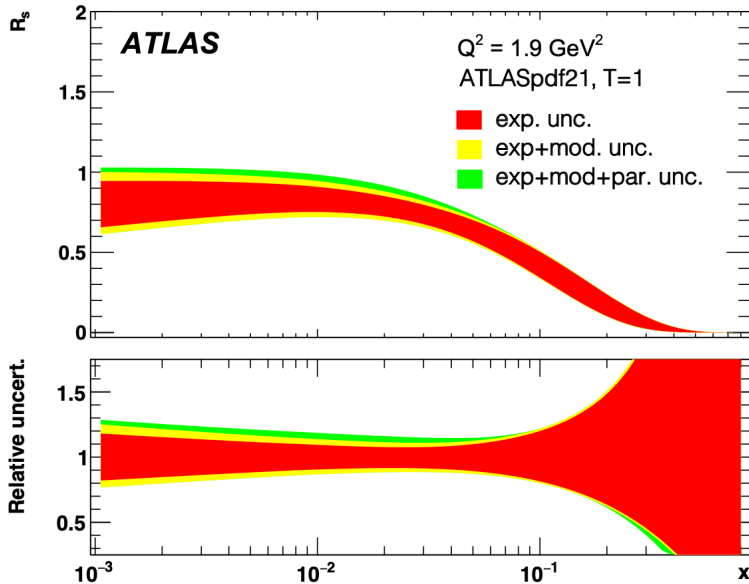

Strange Density @ CMS: W + c

[arXiv:2112.00895]

Final states with W + charm are directly sensitive to the strange density at lowest order

CMS measurements using jets with charm tags from secondary vertices of low p_T^{rel} muons:

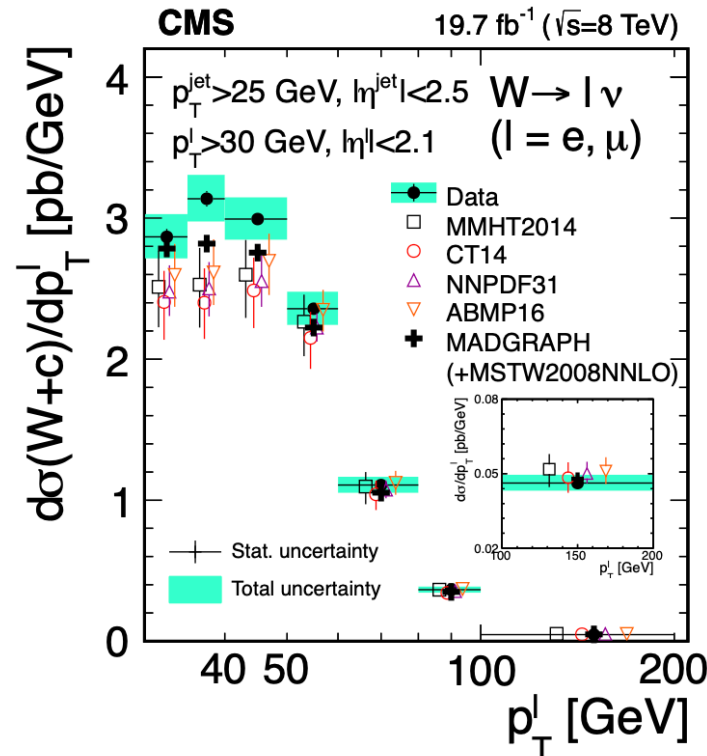
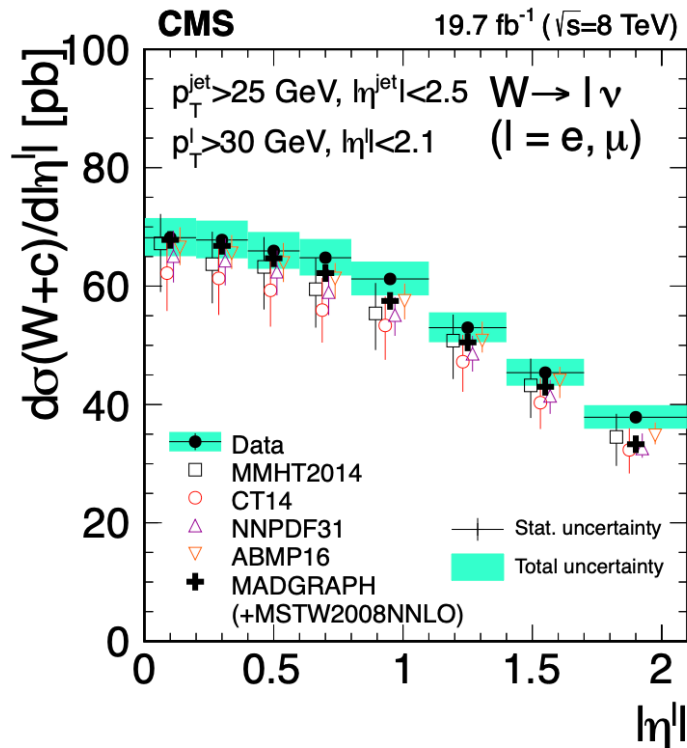
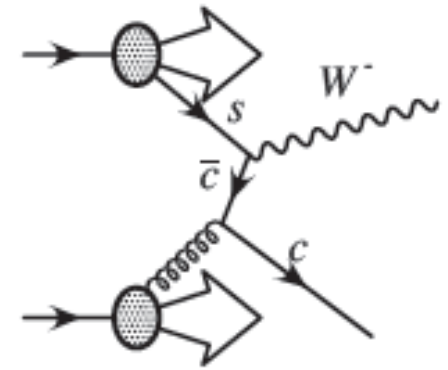

- Reasonable agreement with NLO fits

- Up to 10% disagreements @ low lepton p_T

- Comparisons using NNLO PDFs better?

Strange Density at CMS / Overall Picture

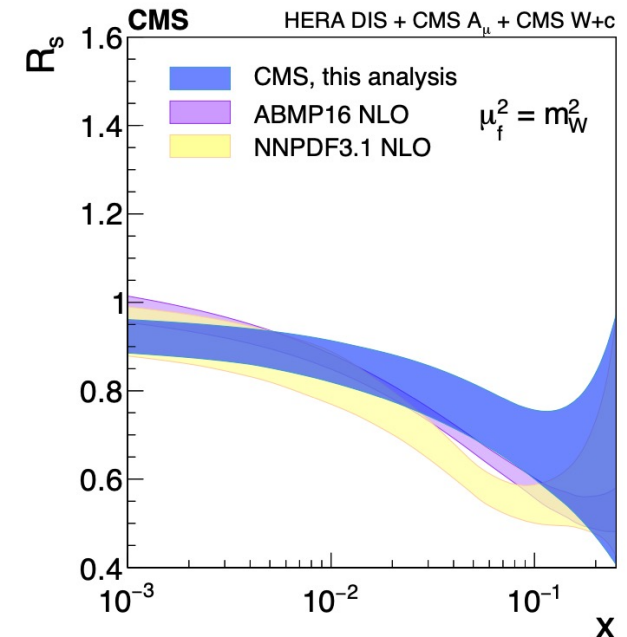
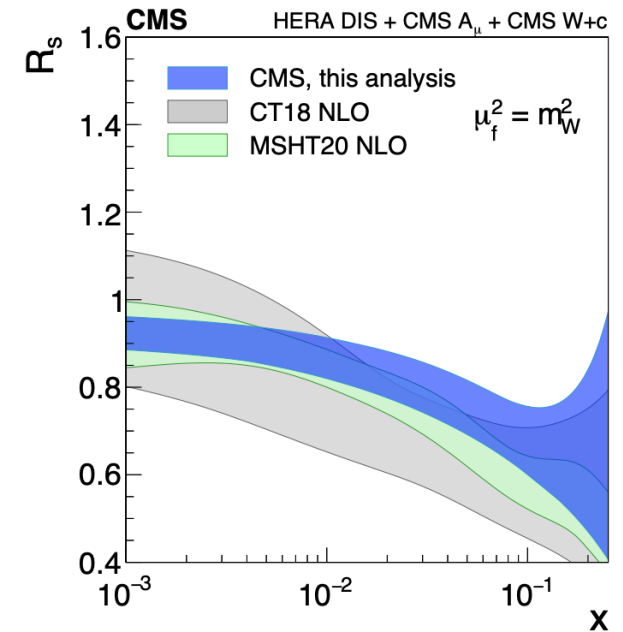
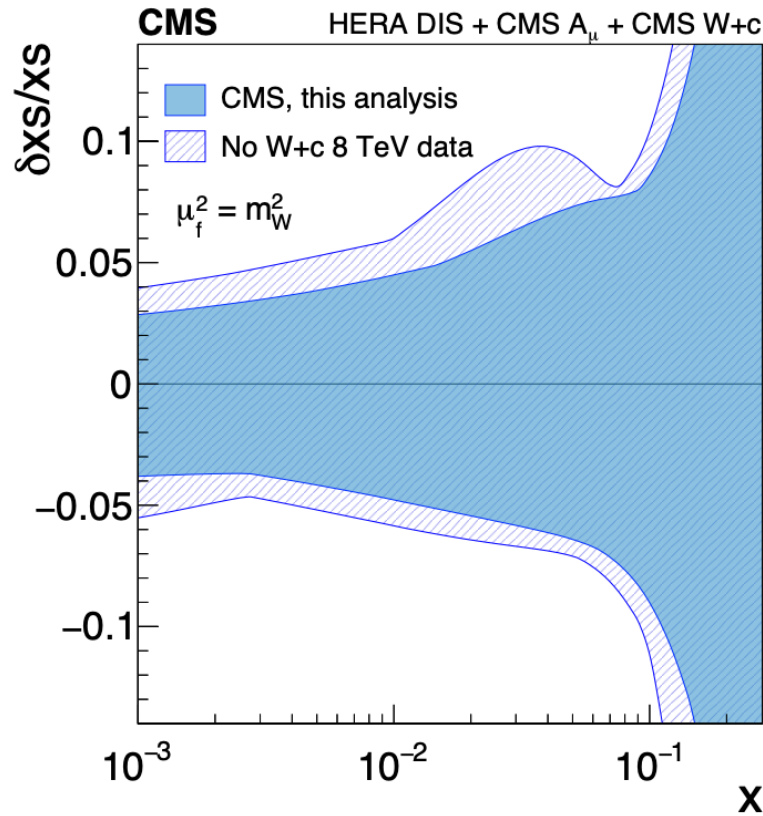

- Including CMS W+c data in fit with HERA data and previous CMS W, W+c data shows significant improvement on strange precision
- Also suggestive of small strangeness suppression at low x

Favourable LHCb Kinematics

“Fixed target-like” forward instrumentation ($2 < \eta < 4.5$) gives sensitivity to asymmetric x values,

... to $x \sim 10^{-5}$ and at $x \rightarrow 1$

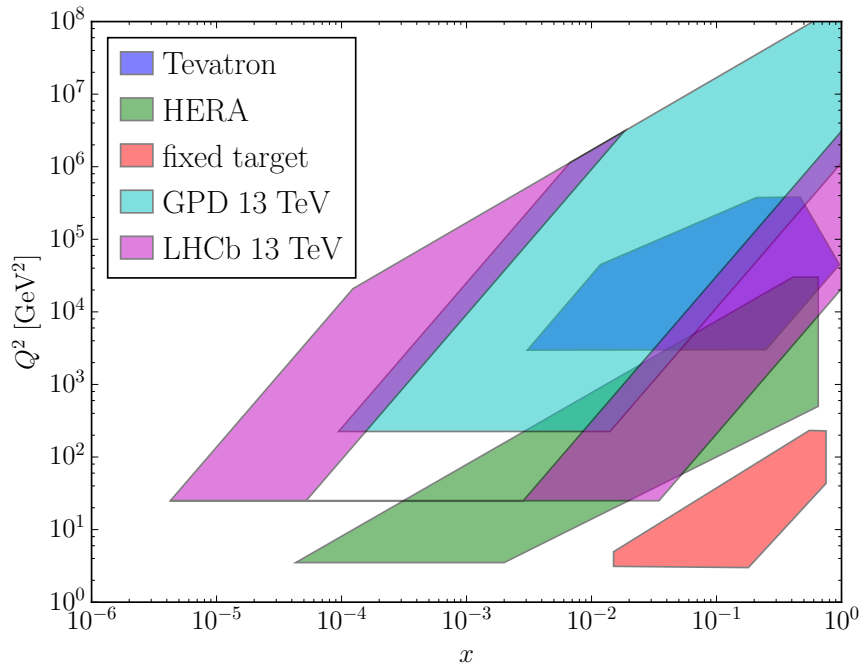

Forward Z+c data provide evidence for intrinsic charm in the proton

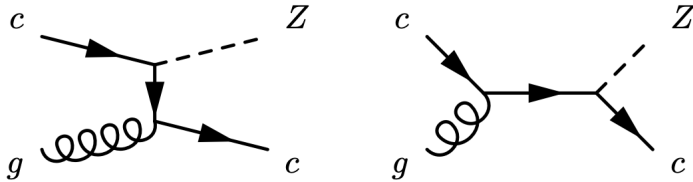

[also NNPDF, Nature 608 (2022) 483]

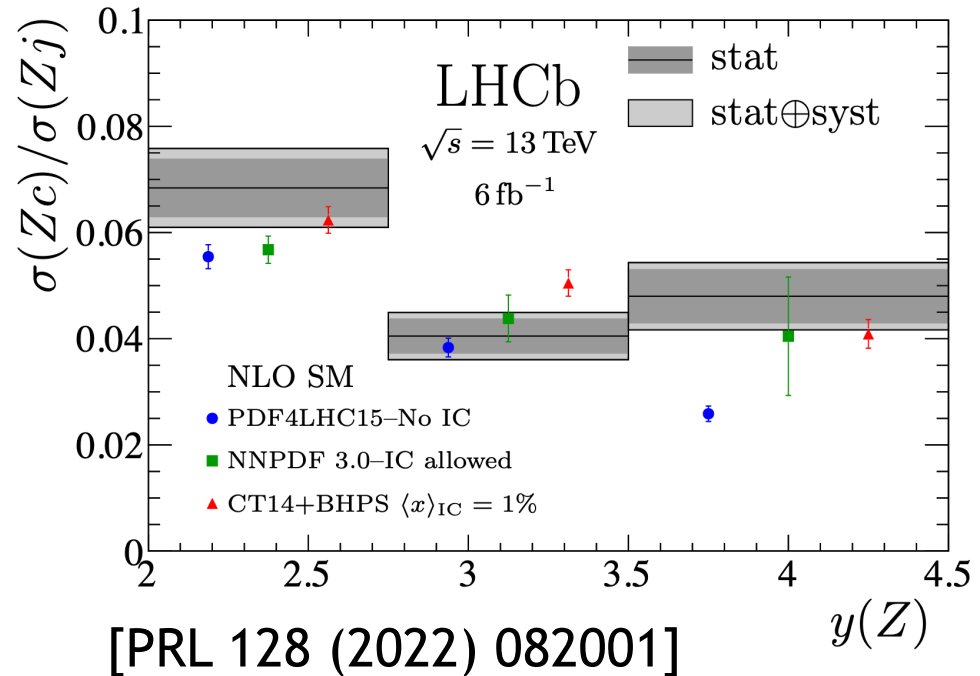

LHCb inclusive Z

[JHEP 07 (2022) 026]

- Broad agreement with fixed (NLO) order predictions based on global fits
- FEWZ predictions systematically low at low rapidities for all PDF sets (corresponding to more modest x).
- Further studies on W, top, Drell-Yan, (not shown here).

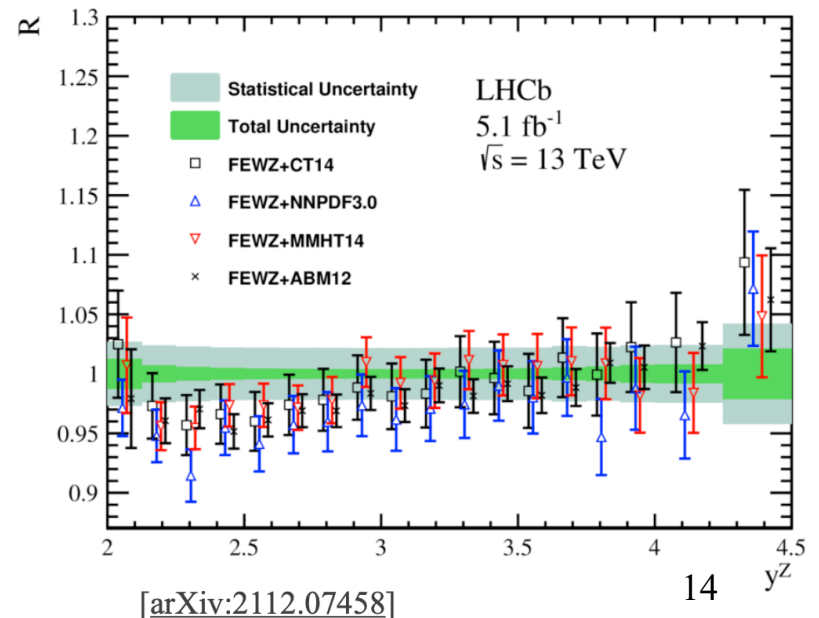
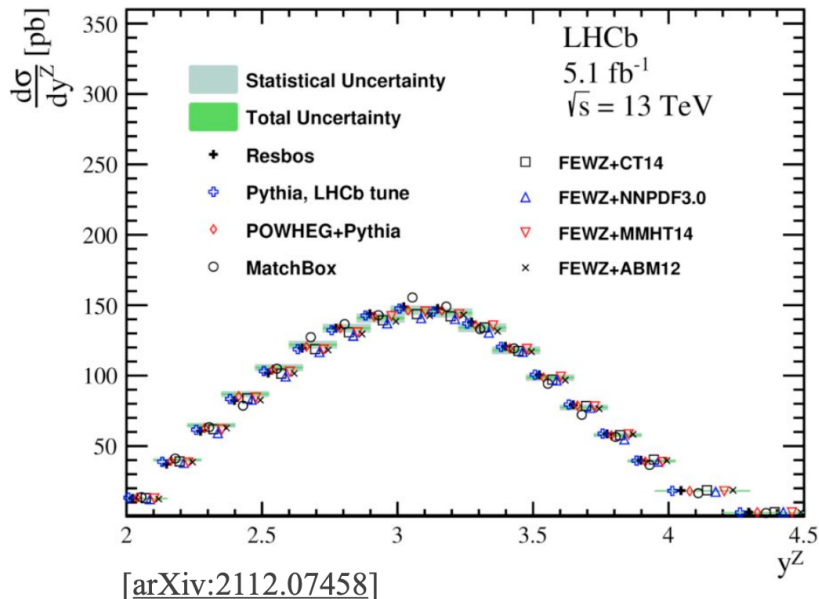
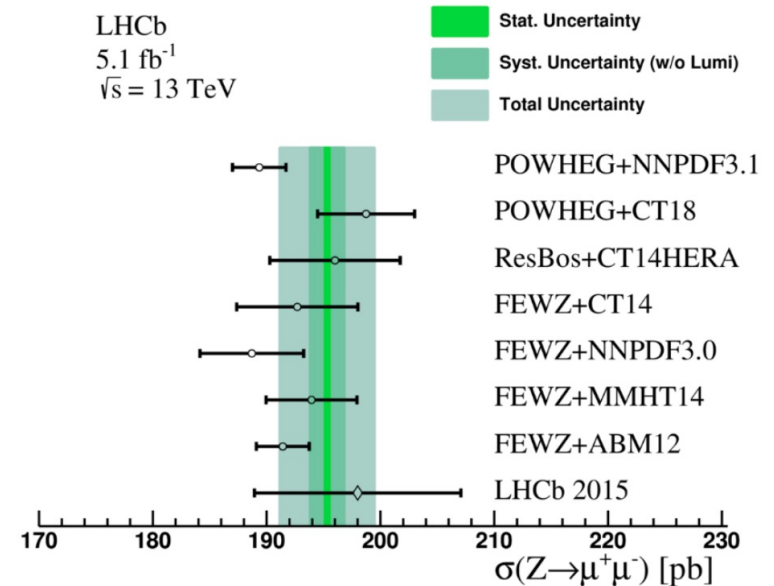

Back to ATLAS: Quality of Description of Data

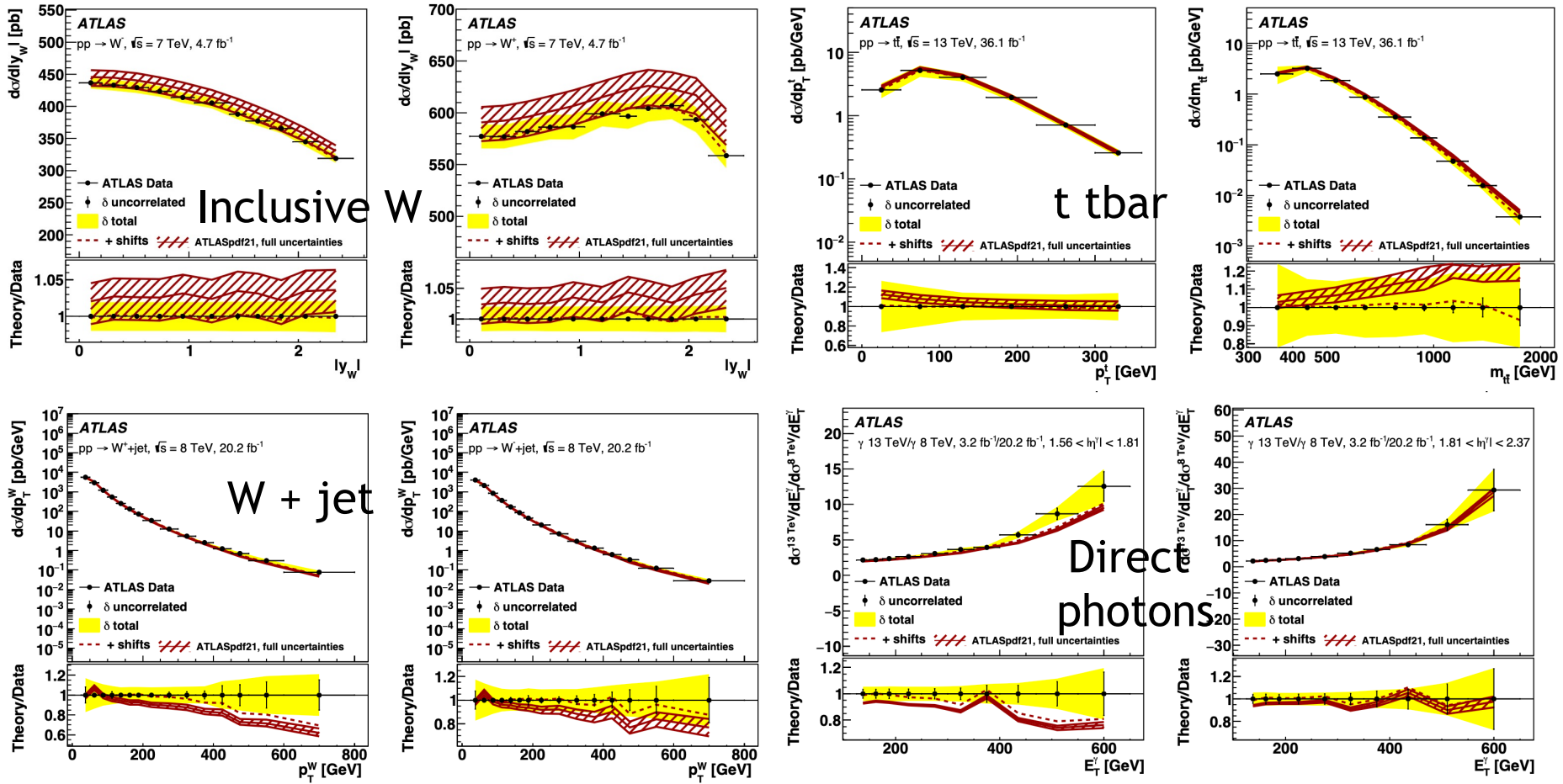

Level of agreement within expectations ... but 5-20% effects remain

Theoretical Limitations:

- Hadronisation and Underlying Event
- Missing higher orders (QCD & EW)
- Large logs needing resummations

Experimental Limitations:

- Systematics (energy scale ...)
- Correlations between measurements

Final Words

- Current state of the art in collinear proton parton densities is driven primarily by HERA + LHC
- LHC brought progress in experimental precision and associated theory understanding for wide range of sensitive observables
- LHC impact primarily at high x and in flavour decomposition
- Future challenges:
 - Need to maintain independence between PDF-based predictions and searches near the kinematic limit
 - Very large $x \rightarrow 1$ region
 - Limits in experimental and theoretical precision
 - Increasing pile-up

Thanks to the Organisers!