

EUROPEAN ORGANIZATION FOR NUCLEAR RESEARCH

CERN/MPS-SI/CO 71-1  
16 February, 1971

THE COMPUTER ASSISTED CONTROL AND DATA ACQUISITION

SYSTEM FOR THE CERN PS BOOSTER

E. Asséo, G. Baribaud, H. van der Beken,  
J. Bosser, J.H.B. Madsen and K.H. Reich

ABSTRACT

For the 800 MeV CERN PS Booster (PSB) strong emphasis is laid on control and data acquisition and treatment by computer. This is because we aim to accelerate a dense beam of  $10^{13}$  p/p after a relatively short running-in period. This accelerator really consists of four superposed and partly independent synchrotrons and a large number of data has to be digested in a short time. A substantial saving is obtained by relying entirely on the computer, leaving out direct manual control. Instead of acquiring a new machine, it was decided to link the PSB to the already well-established IBM 1800 of the CPS. Its capacity will be considerably enlarged to cope with the increased load and to offer software facilities providing a great flexibility for each of the three machines served (linac, PSB and CPS). A satellite computer has been added to act as a function generator in order not to load the IBM 1800 too heavily with real-time work. This paper gives a technical description of the whole system, followed by a survey of the application programs.

Paper presented at the 1971 US Particle Accelerator  
Conference, Chicago  
1 - 3 March, 1971

Distribution

MPS and SI Scientific Staff  
PS Operation

THE COMPUTER ASSISTED CONTROL AND DATA ACQUISITION SYSTEM FOR THE CERN PS BOOSTER

E.Asséo, G.Baribaud, H.van der Beken, J.Bosser, J.H.B. Madsen and K.H.Reich  
CERN, Geneva, Switzerland

Summary

The four-ring 800 MeV CERN PS Booster (PSB), whose running-in is scheduled for spring 1972, is to provide  $10^{13}$  protons per pulse with a high phase space density<sup>1</sup>. The control and data acquisition of the four PSB rings are largely independent of each other, although their operation is to be synchronized with the 50 MeV linac (which serves as an injector) and the CPS (into which the PSB beam is transferred). Many of the control and measurement tasks will be performed with the aid of a computer which is shared with the linac and the CPS. The selection of a central computer operating with the Multiprogramming Operating Executive System (MPX) was made as an optimum compromise between efficiency and economy (e.g. sharing of existing facilities). A large number of analog functions will be generated via a small digital computer, connected to the main computer. This system is discussed in detail and the application programs listed.

Scope of the Controls and Data Acquisition

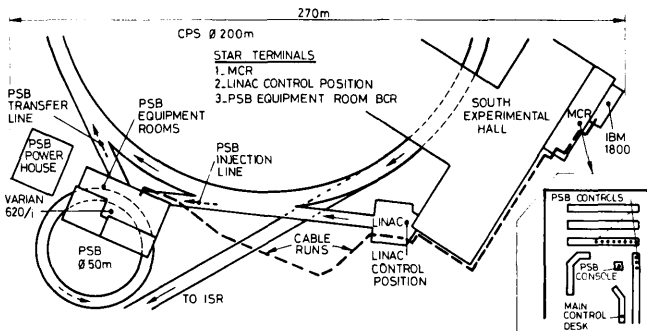

Fig.1 Layout of PSB, linac and CPS controls

The control and data signals have to travel up to about 350 metres between the various control centres (Fig.1). We distinguish three areas: injection line, PSB rings and transfer line. Taking the downstream part of the injection line as an example, Fig.2 illustrates

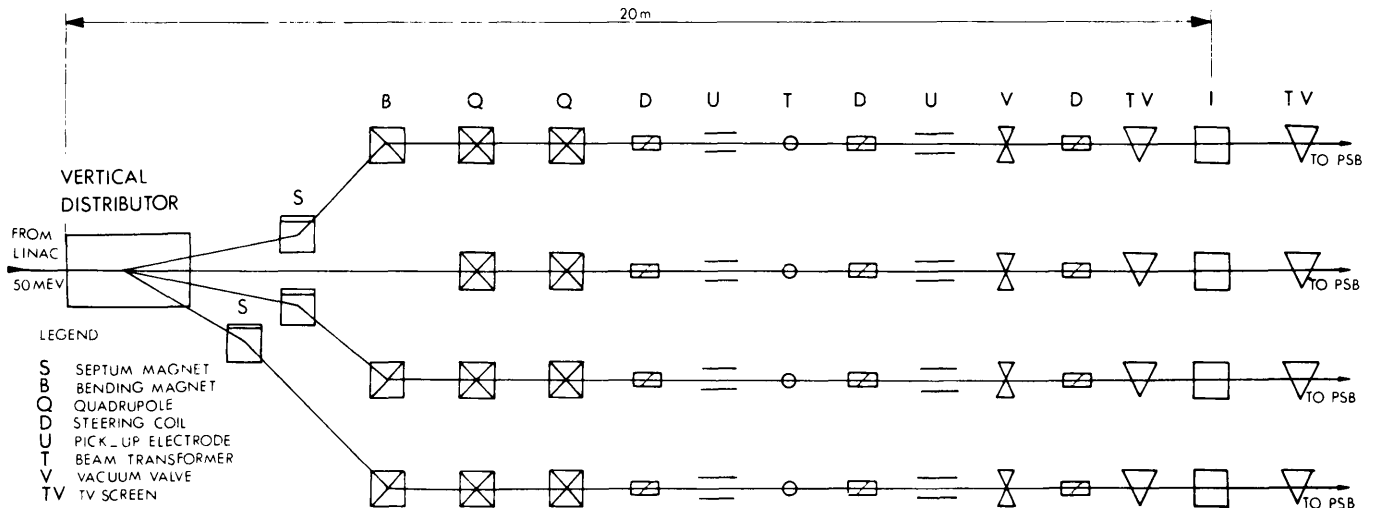

Fig.2 Equipment in second part of injection line

strates the variety of equipment to be dealt with. In general, the four levels (rings) are treated independently, the main exceptions being the inflector settings and the main power supply. The approximate number of elements to be controlled and signals to be acquired are listed in Table I.

Table I Scope of controls and data acquisition

	Controls		Data Acquisition	
	No	Resolution*	No	Resolution*
Magnetic elements	160	1	160	1
	160	0.1	160	0.1
	50	0.01	50	0.01
Other elements	20	1	20	1
	20	0.1	20	0.1
Beam monitors	—	—	350	0.1
Total	410	—	760	—
Number of STAR addresses	256	—	512	—

\* Resolution in % of full scale

As may be seen, the resolution required for the magnet controls covers a rather wide range. Therefore in the case of low resolution, we developed inexpensive solutions<sup>2</sup>, particularly welcome because of the large numbers involved.

The data sent to the computer are remotely digitized in the PSB equipment rooms and transmitted via a multiplexed data way (see section on hardware). Detailed computer analysis of equipment status is planned for later. Analog signals are multiplexed via conventional selectors except in the case of the function generators where signal selection is made via the computer.

Control Philosophy

Location of the Control Room

The addition of a new accelerator to the existing

complex (linac, CPS and experimental halls), raised questions on how best to design and integrate the new controls required. We decided from the start of the PSB project to control it during normal running from one control centre, the Main Control Room (MCR)<sup>3</sup>. This basic decision taken, it was still necessary to define down to what levels the controls should be available in the MCR. We had as an example the system existing for the linac: a reduced number of controls in the MCR, with adequate beam diagnostics and fault indications enabling the operator to know the beam quality and perform certain adjustments. The start-up and fine adjustments of the linac are made from the Linac Control Position. This situation has advantages for those in charge of the linac, but makes it more difficult to maintain optimum conditions during a CPS run. Taking economic aspects into account (minimum staff for the operations, duplication of equipment), we decided to create a complete control position for the PSB in a corner of the existing MCR (Fig.1). After commissioning, it should be possible to start-up, experiment and operate the PSB without manning the local equipment rooms.

#### Role of the Computer

Creating this control position required that all elements should be controllable from the MCR and that a complete data observation system should be provided. Due to limited space available in the MCR, a grouped and concentrated layout of the controls was imperative and was achieved by using a computer as the central element in the control system. Our experience since 1967 with a process control computer on the CPS had shown that it supplies substantial assistance to the operators and experimentalists but that full, or even partial, automation of the accelerator process can be achieved only with great effort<sup>4,5,6</sup>. It was felt that, particularly for a complex accelerator such as the PSB, the human operator is better able to recognize patterns and take decisions in unclear situations, at least in the early stages<sup>7</sup>. Thus, the role of the computer was seen principally in: (i) data acquisition, handling and display; (ii) watchdog functions (the computer measures some characteristic data each machine pulse and, if an anomaly is detected, initiates other readings via a supervisory program, finally displaying the cause to the operator); (iii) book-keeping tasks (logs, records for future setting-up, etc.); (iv) complex measurements which may include control functions (emittance, energy spread, closed orbit, etc.); (v) coupled control functions. To perform all these tasks, we considered whether to acquire a new computer for the PSB or to expand the IBM 1800 which was already in use for the linac and CPS. The latter solution was favoured for reasons outlined in the section on the computer system.

#### Manual Controls

The control system was originally designed in such a way that manual operation of the PSB should remain feasible. This had an important consequence: in cases where computer control of an element was available, direct manual control was also needed. Such a combined computer/manual control system is rather expensive and complicates software. We finally opted for computer-dependency so that all controls are routed through the computer only, which facilitates coupled controls. An example is the setting of the focusing strength of a quadrupole through which the beam passes off-axis. The control coupled to this quadrupole current is a steering dipole which automatically keeps the beam trajec-

tory constant. Another example is an orbit deformation, independent of the PSB working point (the computer would measure the  $v$ -value, compute the dipole currents required for the specified amplitude and issue the control signals). For a few elements, such as the ejection kickers, which were not included in possible computer application programs and which had special controls, straightforward manual control was retained.

#### Man/Computer Communication

It was considered undesirable to restrict communications between man and computer to a single alpha-numerical display, a keyboard and some knobs for varying control settings or selecting analog signals on a scope. Therefore the control system is designed for multiple entry points to enable simultaneous control and observation of various systems and to permit working in parallel on the injection line, the elements in the PSB rings and the transfer line towards the CPS. For this we developed small control consoles, surrounded by corresponding analog signal display facilities. An alpha-numerical display with vector mode on a central console is used for more complex work, combining control actions and complex data displays.

#### Satellite Computer

The computer control system outlined so far reads and outputs data only once per PSB cycle. Real-time operation, i.e. an immediate action upon an interrupt, is restricted to a small number of cases to avoid conflicts between users' requests, leaving more time for programming work. It was decided to provide another computer for applications requiring numerous real-time actions, such as the generation of a large number of analog functions (about 30 to start with). The second computer is dedicated to one job (i.e. to output digital information to terminals which create analog functions). The IBM 1800 is still used as the central computer; the dedicated one, the satellite, is linked to it and uses its facilities, such as printer, disk, etc. The real shape of a function can be monitored by the IBM 1800 which will adapt it until the desired one is obtained, thus forming a closed-loop system.

In summary, our philosophy is: (i) we use the computer extensively as an assistant; (ii) we believe in the use of a multiple number of observation and control setting facilities, and (iii) we have made our hardware/software systems compatible with automatic optimizing processes, which will be introduced as soon as this becomes profitable.

#### Computer System

##### Basic Configuration

The computer system, based on a central computer (IBM 1800) and a satellite (VARIAN 620/i), had to meet the following requirements: (i) carry out some well-defined tasks with industrial characteristics; (ii) be flexible enough to cope with modifications; (iii) serve three machines (linac, PSB and CPS), each with different cycles and different requirements.

After considering the applications required, the decision to expand the existing configuration instead of going to a multiple computer control system was taken for the following reasons: (i) due to the slow cycle (typically 1 to 2 s) one CPU will suffice to complete the required tasks; (ii) this solution eliminates the data links between computers; (iii) sharing of the

central facilities (disk store, fast printer, etc.) is easier; (iv) the use of MPX is a software solution allowing user independence; (v) expansion of the configuration provides each user with a more powerful tool at the least expense.

The drawbacks of this decision are that a greater load is placed on the management of the CPU and that real-time applications become difficult. The first point is counterbalanced by the fact that a single software is used and that co-operation between various programs is easier (common subroutine library, common data store, etc.). The second point raises a more important problem: the implantation of a control computer into a large process. Considering only the final efficiency, allocating one computer to one category of problems seemed the most attractive solution and for this reason real-time problems are allocated to another small computer. The configurations of the computers, with their communication facilities, are sketched in Fig.3 and summarized in Table II.

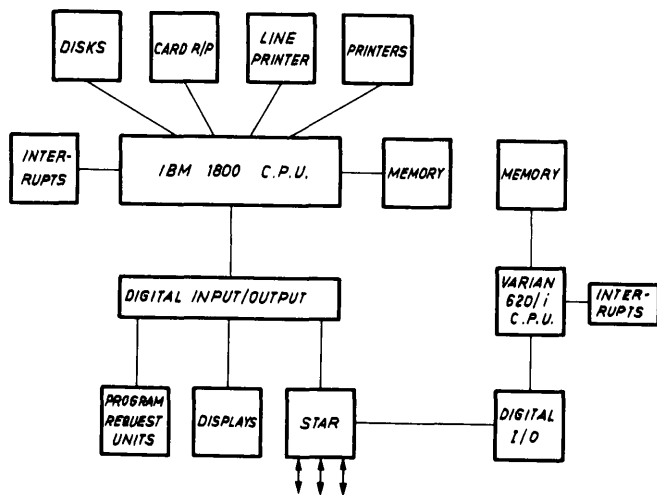

Fig.3 Configurations of computers

The Satellite Computer

Remotely installed, the satellite computer will be able to use, through its data links, the IBM 1800 peripherals for initialization and program development. As it will be used for a very specific task, a home-made system monitor will be employed, as in most fast real-time applications. Interrupts will be serviced by the hardware micro-executive feature.

Software Organization

This is based upon IBM MPX. In fact we consider, based upon our experience, that commercially available and updated software is to be preferred, due to its flexibility and generality, to a home-made one for the main CPU, even if it requires more space (core and disk) and is less efficient for a certain set of applications. The core layout (Fig.4) shows the framework within which programs are handled. The computer performs only a few routine tasks each cycle and is mainly waiting for process or user requests. A common set of programs is executed at the repetition rate of each machine (process requests). User requested programs are executed in their partition of the core store and are allowed to utilise the 8 K of the variable core for a short period of time. The most common subroutines are stored in the EXECUTIVE. We see that an application might use its 4 K, the VCORE (8 K) and the EXECUTIVE subroutines,

Table II Computer Data

IBM 1800	Core Storage	40 K	16+2 bits	2.25 $\mu$ s
	Data Channels	7		
	Digital Output	8	16 bits	500 000 words/s
	Digital Input	8	16 bits	100 000 words/s
	Process Interrupts	3	16 bits	10 $\mu$ s
	Disk Unit	3	512 000 words	36 000 words/s
	Line Printer	1		150 lines/m
	Card Reader/Punch	1		300 cards/m, 80 columns/s
Printers	4		15 ch/s	
VARIAN 620/i	Core Storage	4 K	16 bits	1.8 $\mu$ s
	Digital Output	1	16 bits	202 000 words/s
	Digital Input	1	16 bits	202 000 words/s
	Process Interrupt	56		1 $\mu$ s
	Teletype	1		ASR-33

giving each user an apparent 14 K. Thus, there is an effective total core memory of 42 K as opposed to the 20 K appearing on the core layout. The voluntary restriction on the use of the VCORE is imposed to ensure a better independence of each other of the users' partitions and to allow efficient program development, while leaving the computer on-line. In fact, all the applications have a very low duty cycle (using less than 10% of CPU time) and therefore the batch processing monitor, staying in VCORE, enables program development, which is a major factor in successful computer utilization in our field.

System Monitor	}	EXECUTIVE	17 K
Common Subroutines		SPECIAL PARTITIONS	3 K (ISS)
Routine Programs (20 K)		LINAC PARTITION	4 K
Users' Application programs	}	PSB PARTITION	4 K
		CPS PARTITION	4 K
Interrupt Coreloads		VARIABLE CORE	8 K
Batch Processing			
User's Application			

Fig.4. Core Layout

Software

Extensive use is made of "LOAD ON CALL" and chaining to fit users' programs into 4 K. These programs are mainly written in Assembler language to optimize their efficiency. They are usually called via push-button program request units, which also permit the user to specify some options, such as "Repetitive mode", "print results", etc. Other options might be specified by entering data via keyboard on a graphic-alpha-numeric display.

Application Programs

These programs come under two headings: general (also used for the linac and the CPS) and specific PSB programs. Examples of general programs are LOG (logging of machine settings and beam data), VARYLOG (comparison with previous settings), display programs and those for changing the function generator output. Specific PSB programs include steering of the linac beam and measurements of its properties; measurements of the PSB closed orbit, the frequency of betatron oscillations, the mean radial position and the transverse proton distribution; open-loop correction of the closed orbit; setting of ejection line elements; measurements of beam properties at transfer, etc. Although they will start from the

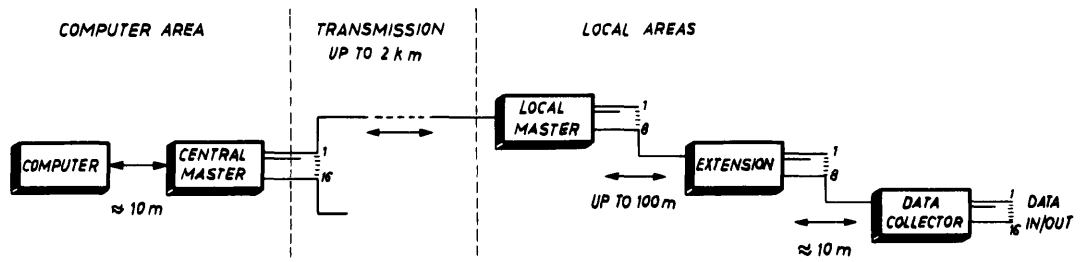

Fig.5 Layout of STAR

basic features, some of these programs are expected to become more complex as further experience is gained, the aim being completely automatic controls or measurements.

The STAR system was installed in 1967/68, and is still expanding. A set of interface modules<sup>9</sup>, STAR-compatible, enables us to cover all current needs. They are listed in Table III.

The Hardware

The measuring and control equipment is concentrated in areas around the linac, PSB and CPS and connected to the computer by a digital transmission system which branches out from the computer room. This system, STAR (Système de Transmission Adressée Rapide)<sup>8</sup>, built at CERN, was designed to suit our needs: to cover large distances (up to 2 km), to serve several areas (16 in all), to have a large capacity (16 384 addresses), to be matched to the functioning of the computer, to provide galvanic insulation between computer and other areas, to be easily expandable (modular concept followed) and to incorporate testing facilities. The layout of the STAR is shown in Fig.5. A minimum of computer time is used for exchange of data with the STAR by employing the data break and external synchronization signal which returns with the data to initiate the reading-in and the next acquisition. For control, the synchronization travels with the data and is used as a strobe signal before returning to generate the next control. With this self-synchronization, the transmission rate depends upon the distance covered. At present, our system runs at an average of 35 K words/s. Transmission is made in words of 16 bits in parallel via telephonic cable. Differential line drivers and floating receivers (using dc transformers) provide a high noise immunity (more than 100 V - 1 MHz). The function diagram in Fig.6 shows that the address selection is common for both acquisition and control modes. Other STAR features are the central transcoders which can convert any decimal code into pure binary (acquisition) and pure binary into BCD (command).

Table III Interface modules

Interfaces - STAR compatible	
<u>Digital Acquisition</u>	
Data gate	8 or 16 inputs of 32 or 16 bits. Levels: positive, negative or contact logic
Scaler and preset	16 inputs for pulse trains. Level: +3 V to +30 V, frequency ≤ 10 MHz. Output: 16 bit words
Memory	16 bits with micrologic level. Output: 16 bits
<u>Digital Command</u>	
Memory	16 bits written by STAR. Output: 16 bits contact logic
Stepping motor	16 bits written by STAR (12 bit increment 1 up/down and 3 bits for other uses)
<u>Analog Acquisition</u>	
A/D	10/12 bits + sign, 15/20 μs by conversion Output: 16 bits
SAAS	12 bits + sign, 16 channels with 1 to 8 samples, 1 channel with up to 128 samples
<u>Analog Command</u>	
D/A	12 bits + sign

The Function Generator

Analog voltages are needed for generating the variable currents of some PSB and CPS magnets. This generation is controlled by the digital computer (the IBM 1800 and its satellite VARIAN 620/i), while the analog voltages are produced by the terminals. The operator can change the form of the analog functions via a console linked to the IBM 1800.

Linearization of the Functions

A function  $f(t)$  is approximated by a series of vectors, each of which is defined by its origin (time,  $t_i$ , and amplitude,  $A_i$ ), slope,  $S_i$  (change of amplitude per time unit) and length (duration,  $D_i$ ). Thus for the time interval  $t_i - t_j$ ,  $f(t)$  will be presented by  $g(t)$  as follows:

$$g(t) = A_i + S_i \cdot (t-t_i) \quad \text{and} \quad |f(t) - g(t)| \leq \epsilon$$

for

$$t_i \leq t \leq t_j$$

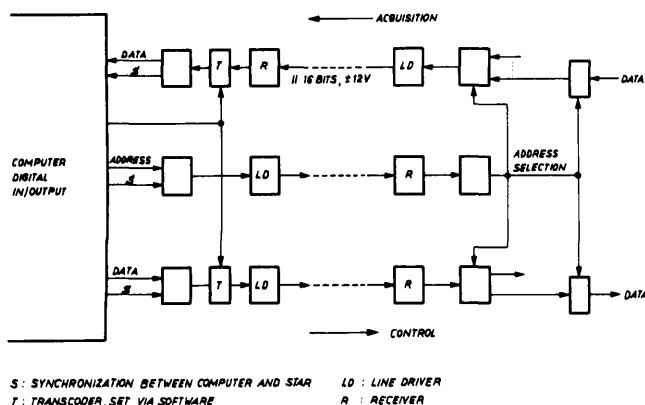

Fig.6 Function diagram of the STAR

Each vector requires three items of data,  $A_i$ ,  $S_i$  and  $D_i = t_j - t_i$ . By using this technique of approximation we minimize the amount of data needed to create the required function as the number of vectors is adapted to the situation, in contrast to a system with a fixed sampling interval.

The digital data defining the series of vectors has to be generated in real-time during the accelerating cycle. By the use of micro-programming in the satellite computer, it can deliver data for a vector every 20  $\mu$ s (i.e. for 50 functions the minimum duration of a vector is 1 ms).

#### Organization of the Satellite Computer and Function Generators

For each function a table is made containing the data for generating the vectors. At the start of the accelerating cycle, the computer sends the data defining the first vector to all the terminals. These data are stored in the buffer memory of the terminal (see Fig.7) and upon the arrival of an external signal, generation of the first vector starts. At each vector start, a request for the next vector is sent to the satellite until the end of the cycle is reached.

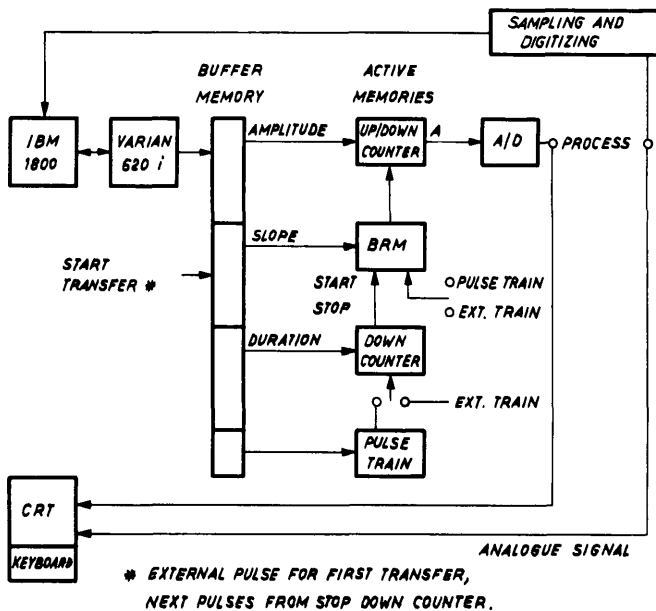

Fig.7 Schematic diagram of function generator

The change in amplitude is produced in an up-down counter, A, (see Fig.7) by a pulse train generated by a binary rate multiplier (BRM). The duration of the vector is determined by a down-counter. These counters are fed by real-time clocks or an external pulse train, for example one connected to the variation of the main magnet field. After the end of each vector, the next data already present in the buffer memory are passed to the active memories. This procedure allows the introduction of discontinuities in the function generated and the start of a new vector can be precisely determined (10  $\mu$ s resolution). The accuracy of the D/A converter is 12 bits plus sign.

A function is changed via a special console<sup>10</sup>. After its data has been copied into a special computer table, the function can be displayed on a CRT, together with another analog signal related to this function.

Upon selection of a vector, its start will be intensified on the CRT with, also, the start of the two following vectors, SP+1 and SP+2. Various manipulations are then possible. For example, the slope of SP can be changed while keeping the time for SP+1 constant. Thus, either the slope of SP+1 is changed or all vectors starting with SP+1 have their amplitudes changed by the same amount. It is likely that the functions will be manipulated so as to optimize the physical analog signal displayed at the same time. This will eventually be done automatically by the IBM 1800, to which the desired analog form will be specified<sup>11</sup>. The programming necessary to implement this is rather complex.

#### Acknowledgements

We are grateful for the support given to this work by G. Brianti and the persons responsible for the various PSB systems. The software was worked out with A. Daneels and W. Remmer, while application programs were conceived by many others, in particular C. Bovet, L. Burnod and H. Koziol. We should also like to thank Mrs. J. Eddison for her assistance in preparing this manuscript.

#### References

1. BIGLIANI, U., NASSIBIAN, G., REICH, K.H., ZANASCHI, D., The RF accelerating system for the CERN PS Booster, Proceedings of this Conference
2. BARIBAUD, G., Contrôle des champs d'un ensemble d'aimants, CERN internal note SI/DL 69-12
3. ASSEO, E., VAN DER BEKEN, H., BOSSER, J., MADSEN, J.H.B., Booster controls, in The second-stage improvement study, CERN report MPS/DL/B 67-19
4. VAN DER BEKEN, H., MACHEN, D.R., MADSEN, J.H.B., SERRE, Ch., The process control computer at the CERN PS: its applications in the operation of a fast ejected beam, IEEE Transactions on Nuclear Science, Vol. NS-16, No 3, June 1969
5. DANEELS, A., On-line optimization of the PS closed orbit at injection, CERN/MPS/CO 70-4
6. BURNOD, L., Mesure de l'ouverture radiale apparente de la chambre à vide du PS par perturbation locale de l'orbite, CERN/MPS/CO 71-1
7. REICH, K.H., Some thoughts on the data acquisition and control systems for the CPS Booster, CERN internal note SI/DL 69-5
8. ASSEO, E., BATTISTI, S., VAN DER BEKEN, H., KOHLER, K., Contrôle automatique du synchrotron à protons du CERN par ordinateur IBM 1800, Colloque international sur la téléinformatique, Paris 1969, Vol. 2, Ed. Chirion, Paris
9. BARIBAUD, G., BOSSER, J., Acquisition des données et commandes pour le CPS Booster, CERN MPS-SI/DL 69-4
10. BOSSER, J., BURNOD, L., Création et modification de fonctions générées par ordinateur, CERN/MPS/CO 71-2
11. BOSSER, J., Thèse 3e cycle, Université de Paris, to be published