

**EUROPEAN ORGANIZATION FOR NUCLEAR RESEARCH**

**CERN – PS DIVISION**

CERN PS/2002-079

**HADRON COOLERS AT CERN**

*P. Belochitskii, J. Bosser, F. Caspers, M. Chanel, T. Eriksson, E.B. Holzer,  
S. Maury, G. Tranquille*

*Abstract*

To provide efficient deceleration and to produce antiproton beam with the required characteristics two different cooler systems (stochastic and electron) are used in operation on the AD (Antiproton Decelerator) machine. In a near future, an electron cooling system will be used in LEIR (Low Energy Ion Ring) to accumulate ions for LHC. This system will be used for a fast ion beam cooling and stacking. These cooling systems are described.

*Paper presented at the XVIII Conference on Charged Particle Accelerators (RUPAC-2002)  
Obninsk, Russian Federation, 01-04.10.2002*

Geneva, Switzerland  
31.10.2002

# HADRON COOLERS AT CERN

P. Belochitskii, J. Bossler, F. Caspers, M. Chanel, T. Eriksson, E.B. Holzer,  
S. Maury, G. Tranquille  
CERN, Geneva, Switzerland

## Abstract

To provide efficient deceleration and to produce antiproton beam with the required characteristics two different cooler systems (stochastic and electron) are used in operation on the AD (Antiproton Decelerator) machine. In a near future, an electron cooling system will be used in LEIR (Low Energy Ion Ring) to accumulate ions for LHC. This system will be used for a fast ion beam cooling and stacking. These cooling systems are described.

## 1 ANTIPROTON DECELERATOR

The simplified low energy antiproton facility at CERN consists of only one ring, the Antiproton Decelerator [1], which produces a beam with a momentum of 100 MeV/c (kinetic energy 5.3 MeV) that is shared by three experiments: ASACUSA, ATHENA and ATRAP.

Protons of 26 GeV/c are ejected from the PS and transferred to a target. There, antiprotons are produced and transferred to the AD. After injection at 3.57 GeV/c (Fig. 1) the bunch is rotated by 90° in longitudinal phase space by a 9.5 MHz cavity system, taking advantage of the short bunch length of about 25 ns. Then the beam is debunched, stochastically cooled, bunched again and decelerated down to 2 GeV/c. There it is stochastically cooled again, primarily to reduce the momentum spread to fit the requirements of the deceleration rf cavity. After the end of stochastic cooling the AD working point is moved from  $Q_x = 5.385$ ,  $Q_y = 5.37$  to  $Q_x = 5.45$ ,  $Q_y = 5.42$  taking advantage of the small emittances to cross the 5<sup>th</sup> order resonance  $5Q_x = 27$ . The first working point provides maximum machine acceptance at injection momentum, while the second places the beam in the region of the tune diagram where more resonance free space is available. This is particularly important at low momenta.

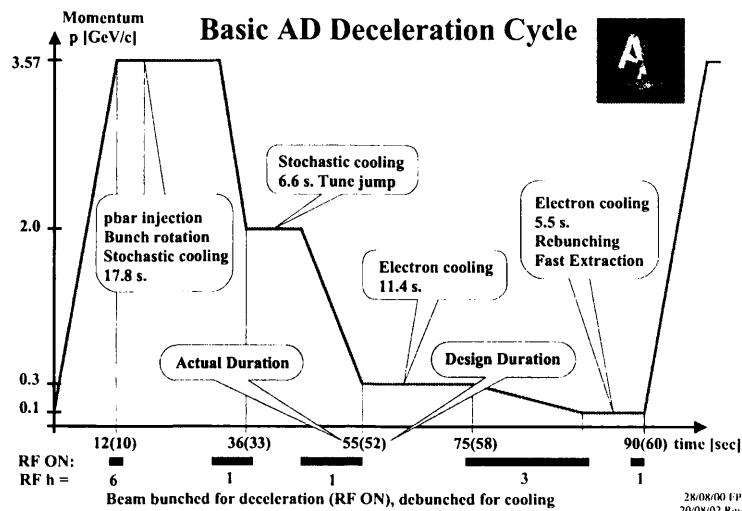

Figure 1. AD cycle

The beam is then decelerated down to 300 MeV/c and cooled by the electron beam from the e-cooler. After cooling, the beam is rebunched on harmonic number 3 (the deceleration rf cavity operates in the range 0.5 – 1.6 MHz) and decelerated to the ejection momentum of 100 MeV/c. Then the antiprotons are again cooled by the electron beam, rebunched on harmonic number 1 (this is necessary to extract all the particles in one bunch, for which the rf cavity

resonant frequency is lowered to 174 kHz by means of a relay-switched capacitor), rotated by 90° in the longitudinal phase space (if experiments demand shorter beam, which is typically the case) and finally ejected.

## 2 AD COOLING SYSTEMS

The performance of the cooling systems is summarized in Table 1. The AAC stochastic cooling systems were rebuilt to cope with the AD requirements. Instead of using the original three frequency bands, (0.9-1.6 GHz, 1.6-2.45 GHz and 2.4-3.2 GHz) only the first of these was kept, due to lattice limitations and other constraints. The same pick-ups and kickers are in use at two different energies. Simultaneous cooling in all three planes is required. Switching between two transmission paths (at 3.5 GeV/c and 2.0 GeV/c) became necessary, including separate notch filters and delay compensation for the kicker sections. The tanks had to be rendered bakeable (150°C) to make the vacuum ( $\leq 10^{-10}$  torr) compatible with deceleration to low energies. Further improvements included programmable, phase-invariant electronic attenuators and amplitude-invariant delays. During commissioning it has been shown that careful optimisation of the notch filters, as well as efficient suppression of the common-mode response in the transverse cooling systems, were essential to reach, and even exceed the design performance. The systems were operated with protons (about  $10^9$ ) as well as  $\bar{p}$  ( $2.5 \times 10^7$ ). During operation over the last two years it appeared that reliable performance could be obtained once the systems were adjusted. Whereas stochastic cooling at 3.5 GeV/c and 2 GeV/c exceeds design specifications, the electron cooling takes a longer time than anticipated before required emittances are obtained. To reach shorter cooling times, several measures were envisaged. The overlap of the electrons with the antiproton beam is carefully optimised by preparing local orbit offset and angle inside of cooler that provides the best performance. The drifts in energy are reduced by elaborate stabilisation; the feedback of electron energy at the 300 MeV/c plateau has been successfully tested.

Table 1. Performances of the cooling (\* refers to 85% of beam), initial transverse emittances of the beam  $180\pi$  mm.mrad and  $\Delta p/p \pm 3\%$

| Momentum (GeV/c) | Cooling System | Emittances ( $2\sigma$ ) |              |              | Cooling time (sec) |        |
|------------------|----------------|--------------------------|--------------|--------------|--------------------|--------|
|                  |                | $\epsilon_x$             | $\epsilon_y$ | $\delta p/p$ | obtained           | design |
|                  |                | [ $\pi$ mm mrad] [%]     |              |              |                    |        |
|                  |                | obtained                 | design       | design       |                    |        |
| 3.57             | stochastic     | 2.0/ 3.6 / 0.07          | 5 / 5 / 0.1  | 5 / 5 / 0.1  | 17.8               | 20     |
| 2.0              | stochastic     | 3.5/3.6 / 0.015          | 5 / 5 / 0.03 | 5 / 5 / 0.03 | 6.6                | 15     |
| 0.3              | electron       | 1.6 / 3.5 / 0.01         | 2 / 2 / 0.1  | 2 / 2 / 0.1  | 11.4               | 6      |
| 0.1              | electron       | 0.5*/0.5*/0.015          | 1 / 1 / 0.01 | 1 / 1 / 0.01 | 5.3                | 1      |

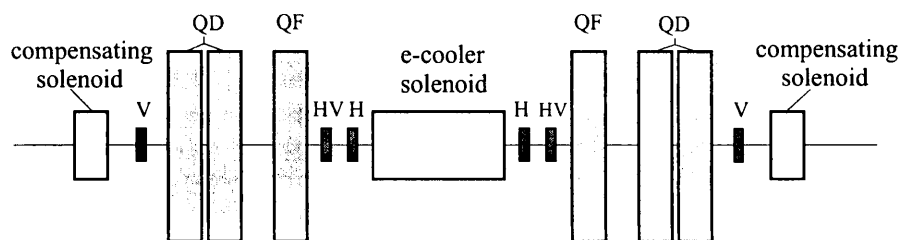

Figure 2. Schematic view of the AD electron cooling insertion

The cooling performance depends also on the optics of the ring. A first step in optics optimisation for e-cooling was done recently by implementing a dispersion of 1.2 m inside of e-cooler (at 300 MeV/c only for the time being due to operational reasons). With non-

vanishing dispersion, the cooling is faster and the horizontal emittance is smaller by a factor 2.5 w.r.t. zero dispersion. The vertical emittance cannot be optimised yet due to insufficient strengths of the vertical dipole correctors (overlap in the vertical plane is not optimal). The layout of the cooling insertion is sketched in Fig. 2.

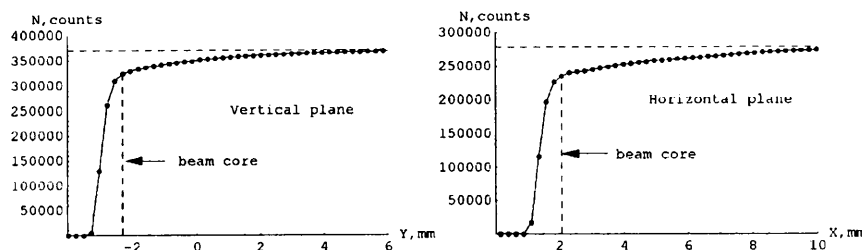

Figure 3. Beam emittance measurements with scraper at 100 MeV/c. The coordinates are the scraper position and the number of counts on a scintillator. The beam core (containing 85% of particles) is shown by a vertical dashed line.

The beam profiles obtained with scraper measurements at 100 MeV/c are shown in Fig. 3. Note the dense part of the beam (“core” about 85%) and the extended tails. The origin of the tails is not clear yet. Probably, they are produced during the cooling process.

### 3 OVERVIEW OF THE IONS FOR THE LHC SCHEME

In addition to proton-proton operation, the LHC will work with heavy ions. The injector scheme, based on the 1993 feasibility study [2], uses the present (moderately upgraded) ECR source (200  $\mu$ Ae of  $\text{Pb}^{27+}$ ), the existing low energy beam transport, RFQ, Linac3 (pulsing at up to 5 Hz), LEAR, the PS and the SPS. While the whole chain will undergo minor modifications, the LEAR machine requires major upgrading for its new role as LEIR (Low Energy Ion Ring) [3].

At the end of Linac3, a first stripping produces a beam of  $\text{Pb}^{54+}$  ( $\sim 20 \mu\text{Ae}$ , 450  $\mu\text{s}$  at present). From LEIR ejection to LHC collision flattop, an overall transfer efficiency of 30% is assumed.

The basic scheme (Fig. 4) is thus to use the modified LEAR ring (LEIR) with strong electron cooling to cool and accumulate the pulses from the heavy ion Linac3, to accelerate them in LEIR, then to transfer and further accelerate them in the PS before extraction to SPS. The upper limit for the luminosity per bunch in LHC is constrained by the requirements to have a sufficient beam lifetime and to avoid quenching of the LHC magnets. The required phase-space density cannot be reached with conventional beams like those produced for the standard CERN Heavy Ion Facility [4] for fixed target experiments at the SPS. The missing factors in intensity and luminosity are of the order of 25 and 1000, respectively. The proposed stacking scheme [5] is aimed at gaining these factors by means of accumulation and cooling in LEIR. The basic scheme has been demonstrated by performing tests in LEAR during the years 1995 to 1997 [6], when the feasibility of the stacking and cooling processes was established. A factor 4 in LHC requirement (2 in time and 2 in intensity) was still missing in the tests, and two unexpected effects discovered:

- the charge state chosen (53+) was subject to a large recombination rate with the electrons of the electron cooling beam. The charge state 54+ proved more favourable and was adopted.
- unavoidable losses of lead ions on the vacuum chamber wall induced strong outgassing (2 to  $5 \times 10^4$  molecules are released by one lost lead ion). Extensive tests have since been launched to find the optimum treatment for the vacuum chamber.

A combined longitudinal-transverse multi-turn injection [5] of 50 effective turns is used to inject about  $2 \times 10^8$  ions into LEIR. Five multi-turn injections, each followed by cooling and

stacking, are needed to reach the required intensity of about  $10^9$  ions. To obtain sufficiently fast cooling the electron-cooling device is designed to have an interaction length of 3 m and an electron current of up to 600 mA. To avoid losses by charge exchange with the residual gas, the vacuum has to be improved to get an ion beam lifetime of the order of 30 s, and the outgassing of the chamber walls by the lost ions has to be minimised. The improvements foreseen for the source, the injection performance, the vacuum in LEIR and the cooling and stacking performance all contribute to reaching the required number of ions per bunch in the small nominal ( $4.5 \cdot 10^8$  ions,  $\epsilon_{rms}^* = 0.7 \mu\text{m}$ ) emittance and in the shortest time possible.

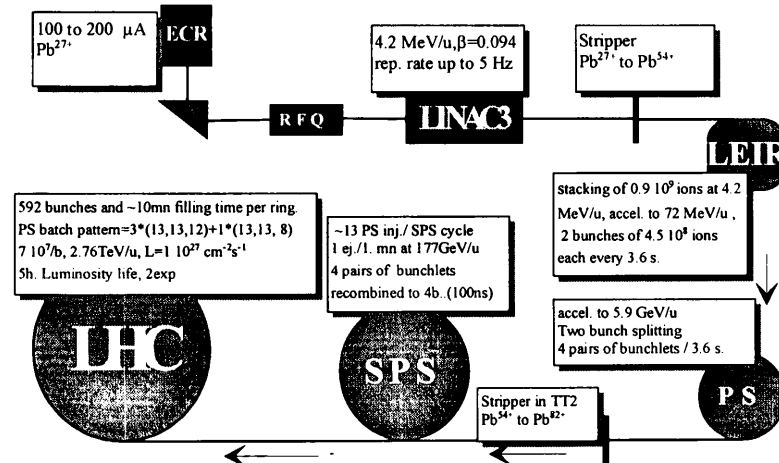

Figure 4: General layout of the production of lead ions beams for LHC

#### 4. PHASE-SPACE COOLING IN LEIR

Phase-space cooling in LEIR is entirely based on electron cooling. As the former LEAR electron cooling device has been installed in AD, a new one has to be built.

With Twiss parameters of  $D = 0 \text{ m}$ ,  $\beta = 5 \text{ m}$  at the electron cooler and an interaction length of 3 m, an electron current of  $\sim 300 \text{ mA}$  enables cooling the beam down to the foreseen emittances in 200 ms. During the tests made in 1997 it has been shown that Twiss beta function values around 5 m are suitable for best cooling rates, and a slightly non-zero dispersion improves the cooling rate. However, to ease daily operation, it has been decided to use zero dispersion at the cooler, thus the ion beam is at the same position in the electron cooler whatever the momentum of the particles.

#### 5. THE ELECTRON COOLER DEVICE FOR LEIR

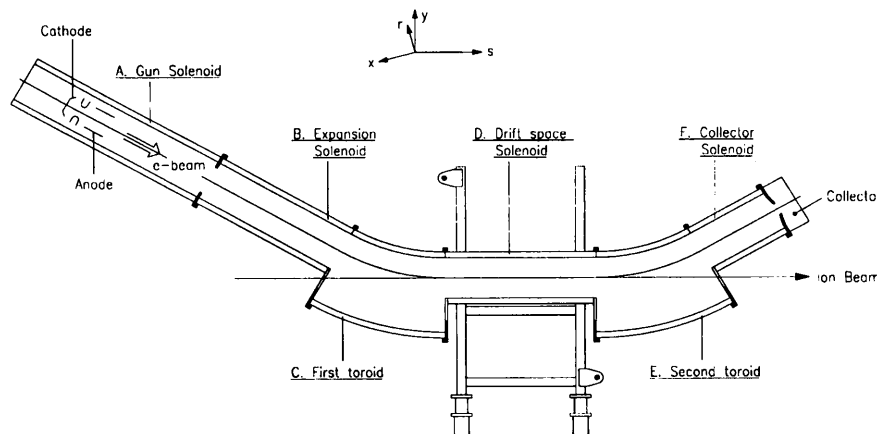

Figure 5: Electron Cooler General Layout

The proposed electron cooler is similar to devices presently in use in several laboratories and at CERN on the AD machine. The principal parts of an electron cooler are shown in Fig. 5.

- A gun provides a dense quasi-monoenergetic electron beam.
- The beam is expanded by an adiabatic factor  $k$  by a dedicated solenoid and is bent by a toroid in order to merge with the ion beam in the drift space.
- At the end of the drift space the electron beam is bent away from the ion beam and finally collected.
- The overall system is embedded in a longitudinal magnetic field to counteract the electron beam space charge forces and to confine the electrons.

Detailed specifications of the overall LEIR electron cooler are given in reference [7,8].

### 5.1 Special Features for the LEIR Electron Cooler

It is foreseen to use a high perveance gun (6 microperv) followed by an adiabatic expansion provided by an additional solenoid (Fig. 5). It aims at providing an electron beam of high density in order to decrease the cooling rate. However, a higher electron density induces an increase of the recombination rate, which is detrimental to the ion beam lifetime, and of the electron azimuthal drift velocity and thus reduces the cooling speed. A compromise must be found.

To obtain the required high densities a convex cathode embedded in a magnetic field of the order of 0.6 T will be used. The lifetime of the cooled ion beam could be increased by a better control of the recombination of the ions with the electron beam, in particular by lowering its density in the centre where the ion stack sits.

The toroids give a horizontal deflection to the ion beam ( $\sim 30$  mrad at 0.1 T central field). To compensate this deflection, a compensating dipole close to each toroid will be installed. The coupling due to the solenoid will be compensated by two solenoids of half the integrated strength each installed on each side of the electron cooler. The tune change of 0.025 will be corrected by trim power supplies on the adjacent symmetric quadrupoles.

### 5.2 Main Parameters

The main parameters of the proposed electron cooler are given in Table 2. Two operational regimes will be used depending on the momentum of the ions to be cooled.

Table 2: Main characteristics of the electron cooling device

|   |   |                        |
|---|---|------------------------|
| Electron beam energy                        | 2.3 keV to 6 keV  | 6 keV to 40 keV        |
| Electron beam intensity                     | 0.05 A to 0.6 A   | up to 3 A              |
| Ion beam momentum-c                         | 88.6 MeV/u to 143 MeV/u                                 | 143 MeV/u to 378 MeV/u |
| Adiabatic factor k                          | 1 to 8  |                        |
| Electron beam radius                        | 9 mm to 25.4 mm   |                        |
| Maximum B field at the gun                  | 0.6 T   |                        |
| Relative current losses                     | $<10^{-4}$  |                        |
| Maximum energy spreads                      | $\Delta_{e\sigma} = 1$ meV, $\Delta_{e\perp} = 100$ meV |                        |
| Drift space length                          | 3 m   |                        |
| LEIR machine Twiss parameters at the cooler | $\beta_h = \beta_v = 5$ m,<br>$D = 0$ m                 |                        |

### 5.3 Beam Diagnostics Associated with the Electron Cooler

The cooling process cannot be optimised without adequate beam monitoring systems:

- Three H+V pick-ups placed at each end and in the middle of the drift space to measure the electron and ion trajectories simultaneously,
- A recombination detector, placed after the first dipole following the e-cooler, it will enable the evaluation of the recombination rate between the ions and the electrons,
- Ionisation profile monitors for both transverse planes,
- Longitudinal and transversal Schottky pick-ups.

#### 5.4 Vacuum

The vacuum pressure, as seen by the ions, must be in the  $10^{-12}$  torr range. The pressure increase within the cooler results mainly from electron losses which must be kept as low as possible with a good collector. The e-cooler will be made entirely bakeable to 300°C and constructed according to the CERN criteria for ultra-high vacuum (special steel, vacuum firing etc.)

## 6. CONCLUSION

In AD, the stochastic cooling and electron cooling systems are successfully used for increasing the efficiency of deceleration and to produce antiproton beams at low momenta with the required characteristics. In LEIR, an electron cooling system will be used as from 2005 for fast heavy ion beam cooling, stacking and emittance reduction for the LHC ion programme. This system is under study at the BINP Novosibirsk.

## 7. REFERENCES

- [1] S. Baird et al., "Design Study of the Antiproton Decelerator", CERN/PS 96-43 (AR), 1996.
- [2] P. Lefèvre, D. Möhl, A Low Energy Accumulation Ring of Ions for LHC (a Feasibility Study), CERN/PS 93-62 (DI), 1993, LHC Note 259.  
P. Lefèvre, Modifications to the Ion Scheme for the LHC, CERN Internal Note PS/DI/Note 95-09 (tech), LHC Note 324
- [3] C. Carli, M. Chanel and S. Maury (eds.), PIL Design Report, to be published.
- [4] D. Warner, Editor, CERN Heavy Ion Facility Design Report, CERN 93-01, 1993.
- [5] C. Carli, S. Maury, D. Möhl, Combined Longitudinal and Transverse Multiturn Injection in a Heavy Ion Accumulator Ring, Proc. PAC97., Vancouver, p. 976.
- [6] J. Bosser, J. Broere, C. Carli, M. Chanel, C. Hill, R. Maccaferri, S. Maury, D. Möhl, G. Molinari, S. Rossi, E. Tanke, G. Tranquille, M. Vretenar, Results on Lead Accumulation in LEAR for the LHC, CERN/PS 98-033 (CA) and Proc. EPAC98, Stockholm, p. 253.
- [7] J. Bosser, V. Prieto, G. Tranquille, Specifications of the LEIR Electron Cooler Magnetic Components, CERN Internal Note PS/BD/Note 2001-018.
- [8] J. Bosser, C. Dimopoulou, G. Tranquille, LEIR Electron Cooler Conceptual Study, CERN Internal Note PS/BD/Note 2001-017.