

Please do not damage the address label  
since it is a re-usable sticker!  
Veuillez ne pas abimer l'étiquette  
d'adressage, c'est une étiquette réutilisable!

From:

Return to: L. Ghilardi, PS Division

Please send me ... copy(ies) of the following report: **CERN/PS 2000-031 (DR)**

---

**CERN/PS 2000-031 (DR)**

## **THE VITROVAC® CAVITY FOR THE TERA/PIMMS MEDICAL SYNCHROTRON**

M. Crescenti, TERA Foundation  
A. Susini, G. Primadei, Consultants to TERA Foundation.  
F.J. Etzkorn, A. Schnase, Forschungszentrum Jülich  
C. Fougeron, LNS-CEA Saclay

### **Abstract**

A proton and light-ion medical synchrotron is characterised by a large frequency swing for the RF between the injection and the top energy. For this purpose, a VITROVAC®-loaded RF cavity has been developed for the Proton-Ion Medical Machine Study (PIMMS) at CERN, and for TERA, the Italian project of a proton and light-ion synchrotron for cancer therapy, based on the PIMMS study. The main features are a large frequency swing, particularly extended to the low frequency range, a very large relative permeability and a low Q factor. The total power needed is less than 100 kW, while a very small bias power is required for the frequency tuning. The main mechanical characteristics are compactness (less than 1.5 m), and simplicity of construction. As a result, the requirements of the medical synchrotron are comfortably satisfied, namely: 0.4 to 3 MHz swing, 3 kV peak voltage at a repetition rate of less than 1 s.

*7th European Particle Accelerator Conference, 26th-30th June 2000, Vienna, Austria*

Geneva, Switzerland

18 July 2000

**Distribution (Abstract)**  
AC, EST, LHC, PS, SL Scientific Staff

**EUROPEAN ORGANIZATION FOR NUCLEAR RESEARCH**

**CERN – PS DIVISION**

**CERN-PS-2000-031 (DR)**

**THE VITROVAC® CAVITY FOR THE TERA/PIMMS MEDICAL  
SYNCHROTRON**

M. Crescenti, TERA Foundation  
A. Susini, G. Primadei, Consultants to TERA Foundation.  
F.J. Etzkorn, A. Schnase, Forschungszentrum Jülich  
C. Fougeron, LNS-CEA Saclay

*Abstract*

A proton and light-ion medical synchrotron is characterised by a large frequency swing for the RF between the injection and the top energy. For this purpose, a VITROVAC®-loaded RF cavity has been developed for the Proton-Ion Medical Machine Study (PIMMS) at CERN, and for TERA, the Italian project of a proton and light-ion synchrotron for cancer therapy, based on the PIMMS study. The main features are a large frequency swing, particularly extended to the low frequency range, a very large relative permeability and a low Q factor. The total power needed is less than 100 kW, while a very small bias power is required for the frequency tuning. The main mechanical characteristics are compactness (less than 1.5 m), and simplicity of construction. As a result, the requirements of the medical synchrotron are comfortably satisfied, namely: 0.4 to 3 MHz swing, 3 kV peak voltage at a repetition rate of less than 1 s.

*7th European Particle Accelerator Conference, 26th-30th June 2000, Vienna, Austria*

*Also available on WWW, <http://preprints.cern.ch>*

Geneva, Switzerland  
17 July 2000

# THE VITROVAC<sup>®1</sup> CAVITY FOR THE TERA/PIMMS MEDICAL SYNCHROTRON

M.Crescenti, TERA Foundation, Via Puccini 11, I-28100 Novara, CERN, Geneva, Switzerland.

A.Susini, G.Primadei, Consultants to TERA Foundation.

F.J.Etzkorn A.Schnase, Forschungszentrum Jülich Postfach 1913, D-52495 Jülich.

C.Fougeron, LNS-CEA Saclay, F-91191 Gif-sur-Yvette Cedex.

## Abstract

A proton and light-ion medical synchrotron is characterised by a large frequency swing for the RF between the injection and the top energy. For this purpose, a VITROVAC<sup>®</sup>-loaded RF cavity has been developed for the Proton-Ion Medical Machine Study (PIMMS) at CERN, and for TERA, the Italian project of a proton and light-ion synchrotron for cancer therapy, based on the PIMMS study. The main features are a large frequency swing, particularly extended to the low frequency range, a very large relative permeability and a low  $Q$  factor. The total power needed is less than 100 kW, while a very small bias power is required for the frequency tuning. The main mechanical characteristics are compactness (less than 1.5 m), and simplicity of construction. As a result, the requirements of the medical synchrotron are comfortably satisfied, namely: 0.4 to 3 MHz swing, 3 kV peak voltage at a repetition rate of less than 1 s.

## 1 INTRODUCTION

The required frequency swing for acceleration in synchrotrons is usually obtained by RF cavities filled with ferrite. The frequency variation is obtained by variation of the inductance of the ferrite by a bias field. The alternatives are amorphous metals or nanocrystalline materials. A cavity filled with such materials keeps in tune with the driving frequency with no or just a small bias current. Instead, hundreds of amperes are required for ferrite. The advantages are small length, large frequency swing, simple mechanical design and a simplified control system. A disadvantage, if very large gap voltages are required, is the low shunt impedance: some hundreds of  $\Omega$  against  $k\Omega$  for ferrite. The TERA/PIMMS medical synchrotron requires 3 kV peak voltage and a 0.4 - 3 MHz frequency variation [1]. Due to the low injection frequency, it is difficult to find a ferrite able to cover the full swing [2]. Therefore, to avoid harmonic number changes during acceleration, two cavities are needed, with a more than 3 m ring occupation. One cavity filled with a material able to cover the full swing would occupy only 1.5 m. In 1996 the LNS experimented VITROVAC 6025, an

amorphous metal Co-based alloy produced by VACUUMSCHMELZE. In low power tests a swing of 0.2 to 10 MHz has been reached. In high power tests a 1.5 kV peak voltage was obtained at 1 MHz. In 1997, TERA acquired the prototype and continued the experiments at CERN. A 2x50 kW amplifier from COSY was modified by TERA by improving the shielding and developing new RF filters. The installation is shown in Fig. 1.

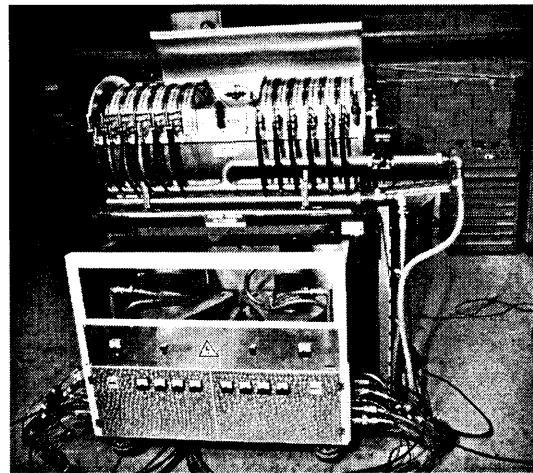

Fig.1 Set-up of the system in the LNS early version, with the 2x50 kW COSY amplifier based on Thomson TH120 tetrodes.

## 2 THE MATERIAL

In Table 1 the main parameters of the material are given. It is delivered as a 25  $\mu\text{m}$  thin ribbon wound in the shape of a toroidal core. Each turn is electrically insulated from the next one by a 0.2  $\mu\text{m}$  thin film. The maximum permeability is  $10^5$  at very low frequency, and is  $1.5 \cdot 10^3$  at 10 MHz. The sensitivity to the bias field is high: 0 - 50 A for 0.2 - 10 MHz. A water cooling copper ring is sandwiched between two cores, forming a so-called magnetic module. The very efficient cooling assembly, untouched from the original structure, can dissipate up to 1.35 kW per core.

Table 1 Main parameters of VITROVAC 6025F cores.

Disk internal diameter [mm]	355
Disk external diameter [mm]	510
Thickness [mm]	25
$\mu_r$ at 0.2 MHz	$3 \cdot 10^4$
$\mu_r$ at 10 MHz	$1 \cdot 10^3$

<sup>1</sup> Produced by: VACUUMSCHMELZE GmbH, Grüner Weg 37, P.O. Box 2253, 6450 Hanau 1, Germany.

### 3 MECHANICAL DESIGN OF THE CAVITY

The LNS structure has been modified and completed, (see Fig.2), to allow high power operation, which was not possible before. The new shape simplifies the internal access and the coupling with the amplifier.

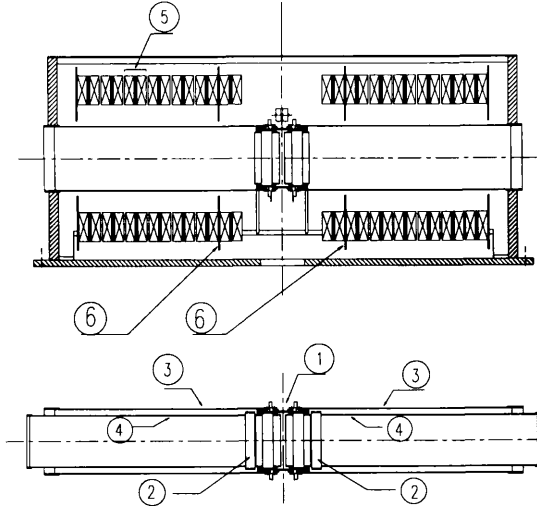

Fig.2 Cavity technical drawings. Top: longitudinal section of the assembly. Bottom: schematic view of the vacuum pipe. The gap (1), the bellows (2) the copper envelope (3), the vacuum pipe (4), a magnetic module section (5) and the support plates (6) of the bias windings (not represented).

Two face-to-face  $\lambda/4$  transmission lines operate in push-pull. Resonance at the lowest frequency is set by a 130 pF capacitor. 12 magnetic modules are aligned around the vacuum pipe, and space is left for other 2 modules. 14 modules are represented in Fig.2. Two bellows (2) protect the ceramic gap (1) from mechanical stresses. To avoid heating the bellows, the RF current path to ground is via a thin copper line (3) surrounding the vacuum pipe (4). Sliding contacts allow thermal dilatation between the ceramic gap and the copper line. The magnetic modules are biased by four, 4 mm diameter, figure-of-eight windings, repositioned from the original design to avoid breakdowns, and kept in place by four polypropylene insulating plates (6). The measured shunt impedance is shown in Fig. 3. The Q factor has been also measured and is of the order of one. For a 0.4-3MHz swing, the bias current is less than 20 A. The main parameters of the cavity are listed in Table 2.

Table 2 Main parameters of the cavity

Number of disks	2x12
Total cavity length [m]	1.5
Shunt impedance [ $\Omega$ ] (0.4 MHz)	2x400
Q factor	1
Frequency swing [MHz] (harmonic number=1)	0.2-10
DC bias current [A] (4 windings, 0.4-3 MHz)	1-18

### 4 MEASUREMENTS

The requirements of the medical synchrotron, are presented in Table 3 [3].

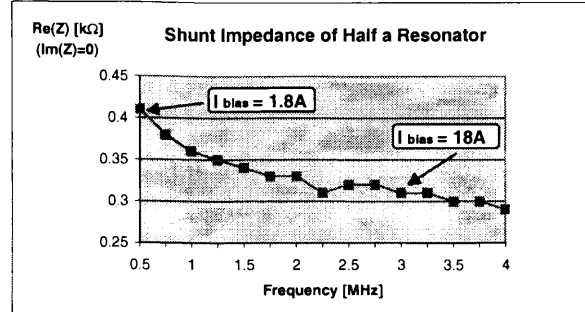

Fig.3 0.5-4MHz shunt impedance of half a resonator measured with HP4815A vector impedance meter. The cavity impedance is twice this value.

Table3 Basic parameters for proton and  $^{12}C^{6+}$  acceleration.

	Injection		Extraction	
	$p^+$	$^{12}C^{6+}$	$p^+$	$^{12}C^{6+}$
Number of particles	$6.8 \times 10^{10}$	$7.9 \times 10^8$	$6.8 \times 10^{10}$	$7.9 \times 10^8$
Energy [MeV/u]	20	7	250	400
Rev. frequency [MHz]	0.81	0.486	2.445	2.85
	$p^+$		$^{12}C^{6+}$	
Max. RF voltage [kV]	2.9		2.7	
Max. phase [deg]	16.9		20.6	
RF harmonic number h	1		1	
Frequency swing	3		5.9	
Max. tuning rate [MHz/s]	10.4		6.0	
Min. time for RF cycle [ms]	167.6		402.4	
Min. trapping voltage [V]	29		35	
Max. trapping voltage [V]	290		350	

The tests have been performed without beam. The schematic set-up is presented in Fig.4. The low-level signal generation is based on the digital function generation techniques developed at COSY [3]. The computer sets the frequency word, which is fed to a numerical oscillator (NCO) and a DAC outputs the driving frequency at constant amplitude. The signal is split into two  $180^\circ$  phase shifted signals, which are the inputs to a 2x500 W commercial driver amplifier. A 12-bit DAC 0 – 10 V is programmed to output the required voltage for pre-regulation of the bias current. The voltage follows a cubic law set by interpolation of the fixed frequency values at resonance. A feedback loop then controls the final tuning voltage. Another feedback loop sets the voltage amplitude at the gap with respect to a programmable reference value. The gap signal is measured with a capacitive divider (1:1000). The 0.4 - 4 MHz fixed frequency measurements show a signal-to-noise ratio better than 60 dB at the accelerating gap when the system is in tune. This is true for high voltage (3 kV) as well as for low voltage levels (~30 to 300 V) required for beam trapping. In Fig.5 is presented an example of the tested RF cycles. The first signal represents the tuning current to the cavity from the bias power supply. The second represents the voltage at the gap in kV. The voltage reaches 3 kV before the end of the sweep, as required by the theoretical RF cycle.

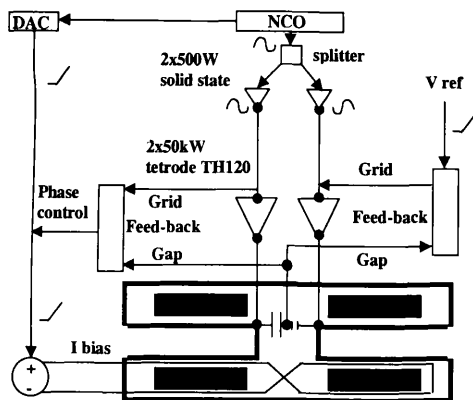

Fig.4 Scheme of the measurement set-up.

Accelerating sweeps below 100 ms can be simulated with a repetition rate below 0.5 sec. The phase stability between gap and grid of the power tubes is better than  $2^\circ$ . The maximum peak voltage obtained for a sweep of 0.4 – 4 MHz is 4 kV.

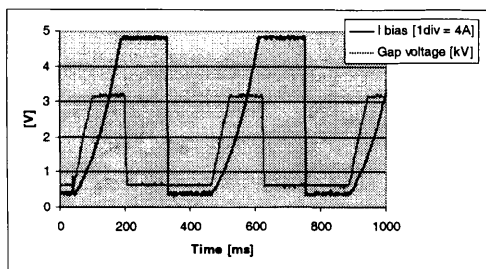

Fig.5 Example of a 0.4 - 4 MHz frequency sweep, with a sweep time of 170 ms. The large signal represents the bias current ( $1 V = 4 A$ ), the other represents the gap voltage in kV.

## 5 CONSTRUCTION OF THE NEW AMPLIFIER

At the end of 1999 the amplifier was returned to COSY and TERA started the construction of a new amplifier. The new design is based on 70 kW SIEMENS 1084 tubes. Two symmetric, independent modules will be installed below the resonator. The configuration, presented in Fig.6, is a grounded cathode, class A, push-pull operated. Despite low efficiency, this mode produces low distortion. Low distortion is needed because there is no filtering by the wide bandwidth resonator. The noise from the tube heating is reduced by optimising the control grid working point via a variable resistor. To increase tube lifetime, thermal stresses to the filament at switch on and off are reduced by slowly reaching the voltage working point with a motorised VARIAC. In Fig.7 one amplifier module is shown during construction. The performances expected from the new amplifier are of 0.3 – 10 MHz bandwidth and 8 kV peak voltage.

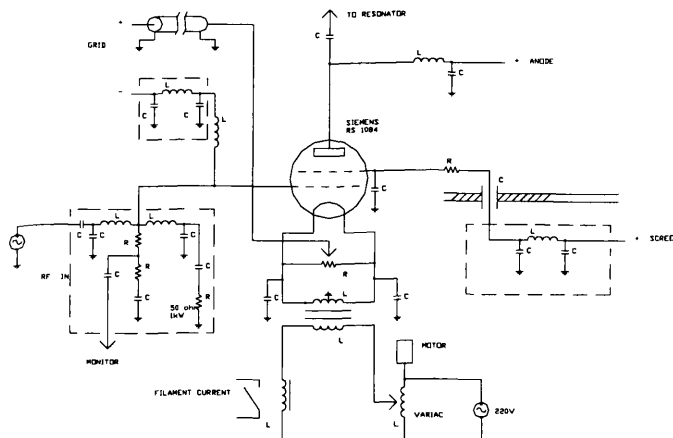

Fig.6 Configuration of the new amplifier module based on the SIEMENS RS 1084 tetrode.

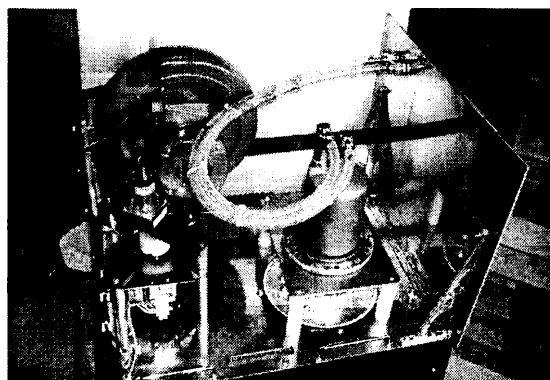

Fig.7 The amplifier module during construction. On the right the RS 1084 power tube mounted on its socket, on the left the motorised VARIAC and an air-cooler fan. Dimensions: width 530, height 690, depth 720 mm.

## 6 CONCLUSION

The cavity satisfies all the requirements of the TERA/PIMMS RF cycle. The construction of the new amplifier is to be finalised. Installation and tests are planned in summer 2000. If financing continues, the RF system can be commissioned for the end of the year 2000.

## ACKNOWLEDGEMENTS

Many thanks are due to CERN/EP for providing the space for the laboratory, and to CERN/PS for the instrumentation loan.

### References

- [1] Accelerator Complex Study Group supported by the Med-AUSTRON, Onkologie-2000 and the TERA Foundation and hosted by CERN, *Proton Ion Medical Machine Study (PIMMS) Part I*, CERN/PS 99-010 (D1) (December 1999), Part II in preparation.
- [2] A.Schnase, H.Rongen, H.Meuth, *A Digital Synthesizer and Phase Control System for RF Acceleration in COSY, EPAC 1992*.
- [3] M. Crescenti, P. Knaus, S. Rossi, *The RF Cycle of the PIMMS Medical Synchrotron*, These Proceedings.