

19.8.1986

PRESENT STATUS AND FUTURE PLANSCONCERNING SOME ASPECTS OF THE SWITCHED POWER LINAC

S. Aronson (BNL), F. Caspers, H. Haseroth, J. Knott

1. Introduction

The switched power Linac as proposed by W. Willis¹) has many interesting features, but also technological problems. The important aspects of fast laser pulses acting on very special photo cathodes are already dealt with in other laboratories having the necessary expertise, manpower and equipment.

For this reason we have concentrated so far on measurements concerning the pulse propagation and enhancement on the proposed accelerating structure and voltage holding tests on small gaps for short times.

2. Present Hardware Status

The proposed final accelerating structure is very small and requires presumably mechanical tolerances which will be hard to achieve. The dimensions in the accelerating gap are prohibiting easy measurements of axial and radial field components in the gap. These are important to judge the effects of misalignment or mechanical errors which are difficult to calculate.

Hence, we have build a scaled-up model with 2.4 m diameter shown in Fig. 1 to study these effects. This model allows also to test the effects of unequal firing (in space or in time) of the discharge of the wire triggered by hitting the photo cathode with a laser beam. For this

purpose a large number (64) of feeder points has been placed along the circumference of the model. Homogeneous feeding is obtained with a special broadband power divider network²⁾ built for that purpose (Fig. 2). The discharge is hence simulated by feeding in a fast (~ 1 ns) pulse from the outside. Alongside one diameter small pick-up probes are installed to measure the electric field as a function of the radius. Before closing the structure all probes are calibrated in situ with a stripline covering the radius of the disk.

The behaviour of the described model in the time domain is being studied via measurements in the frequency domain by applying synthesized pulse techniques.

3. First Results

A preliminary series of tests with E_z probes has been performed with a HP 8510 network analyzer. For reasons related to this instrument the passband had to be limited mostly to 2 GHz.

After checking the feeding of the divider network and the coupling to the structure, measurements were concentrated on pulse propagation from the periphery to the centre and the pulse enhancement, as well as studies concerning the non-uniform feeding in order to simulate failures from the photo diode switch.

Enhancement

So far, we can confirm the theory of the enhancement to follow:

$$\epsilon(r) = \frac{U(r)}{U(R)} = \sqrt{\frac{R}{r}}$$

- ϵ : enhancement factor
- $U(r)$: voltage at radius r
- R : outer radius of structure

This holds as long as the measured pulses do not overlap (Fig. 4). For the central probe and the first outside the centre the signals obtained increase by superposition as expected. In practice, a finite risetime or bandwidth will prevent the overall enhancement to go to infinity³).

Measurements with different passbands of the network analyser permitted a first guess of the bandwidth dependency (Fig. 5a).

For ease of presentation we define an "effective radius" as follows:

$$\epsilon_{\text{meas}} = 2 \sqrt{\frac{R}{r_{\text{eff}}}}$$

From Fig. 5b it follows that r_{eff} is at first approximation proportional to the wavelength (up to 2.5 GHz).

Non-uniform Feed

Disconnecting 1/16 of the feeds successively around the periphery leads to a global loss of ~ 6% in the centre. The field distribution measured is plotted across the model (Fig. 6).

4. Future Plans

Pulse Propagation and Enhancement

After some minor technical improvements of the model and the addition of more probes, especially for measuring radial field components, we expect to continue the measurement programme with a new, more powerful network analyzer:

- enhancement as function of bandwidth
- radial field components in the accelerating gap
- influence of asymmetric feed (1/32, 1/16 etc. disconnected)
- influence of less homogeneous feeding (32, 16 or 8 feeds only).

High Voltage Hold-Off

In parallel, we will study vacuum breakdowns for very short pulses to simulate the situation at the photodiode during charge transfer with 100 kV/mm for a few nanoseconds. At the centre of the final structure there should be fields of the order of 1 MV/mm for 10 pico-seconds. As this situation will probably not be accessible without the real photodiode switch, we hope to extrapolate from measurements done at 1 and 10 ns. They seem feasible after first tests with a 1 KV Blumlein at atmospheric pressure and a pulse width of 2 ns.

We plan to build pressurised versions with voltages up to 100 kV using small overstressed spark gaps and pulsed charging with a Marx generator.

High-Power Synthethic Pulse Techniques as Alternative to the Photo Diode Power Switch.

Different methods to feed the structure with pulses were discussed:

Pulse generation by frequency modulation and subsequent compression in time with a dispersive line is one possibility.

As the model is resonant in the sense that the fed-in pulse goes several times through the structure without distortion, resonant excitation with repetitive pulses is feasible.

These repetitive pulses can be Fourier synthesized by means of feeding the structure with the fundamental frequency together with higher harmonics.

Finally, a proposal has been made for excitation of the structure with non-harmonic but phase locked frequencies⁴).

References

- 1) W. Willis, "Switched Power Linac", Proceedings of the CAS-ECFA-INFN Workshop, Frascati, Sept. 1984.
2. S. Aronson, F. Caspers, J. Knott, "Broadband Transformers" (to be published).
- 3) F. Caspers, "A Synthetic Pulse Method for Excitation of RF-Accelerator Structures", PS/AA/Note 86-9.
4. R.E. Cassell, F. Villa, "Study of a High Gradient Pulsed Linac Structure", SLAC-PUB 3804, October 1985.

Figures

- 1) Structure
- 2) Transformer and network
- 3) Enhancement theory versus measurement
- 4) Pulses at different radii as measured with network analyser.
- 5) a) Enhancement versus bandwidth
b) Effective radius versus bandwidth
- 6) Equipotential plot for asymmetric feed (1/16 off).

Distribution :

Linac Group Scientific Staff
CLIC (discussion meeting)
NEST

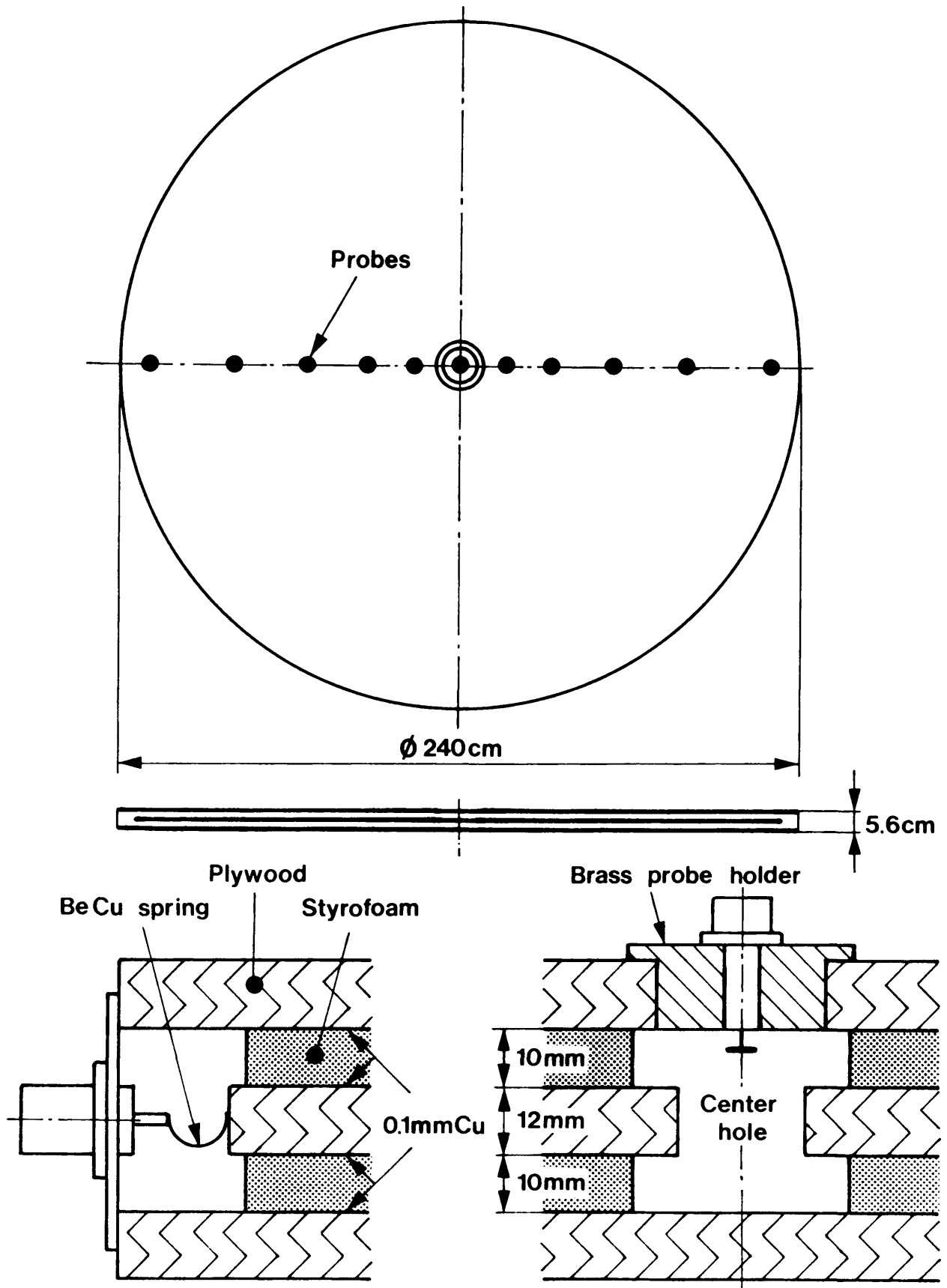

Fig. 1: Structure

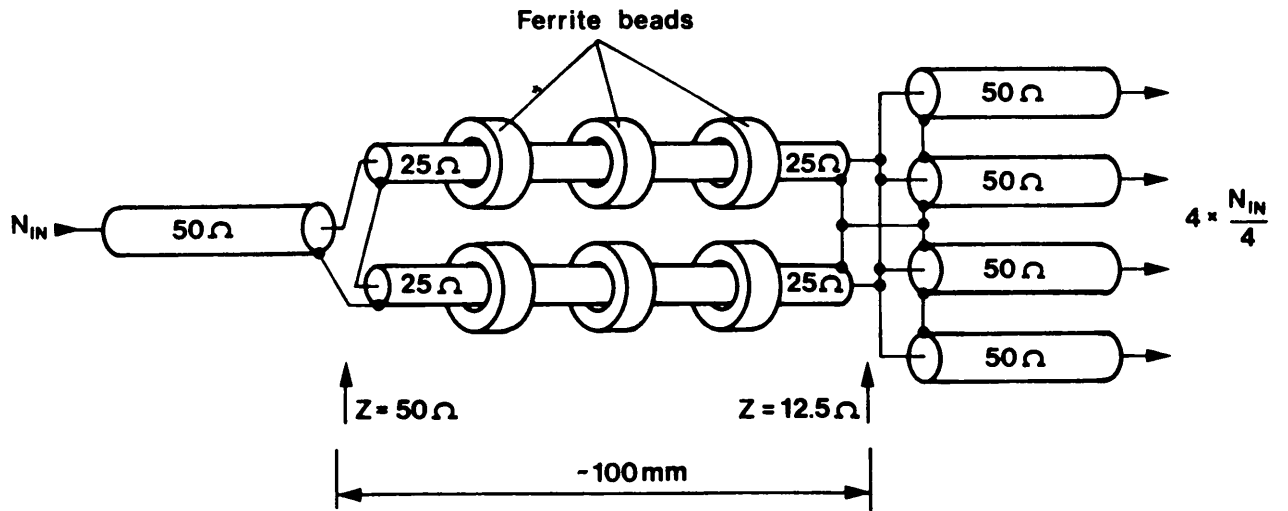

Fig. 2a: Broadband power divider / transformer

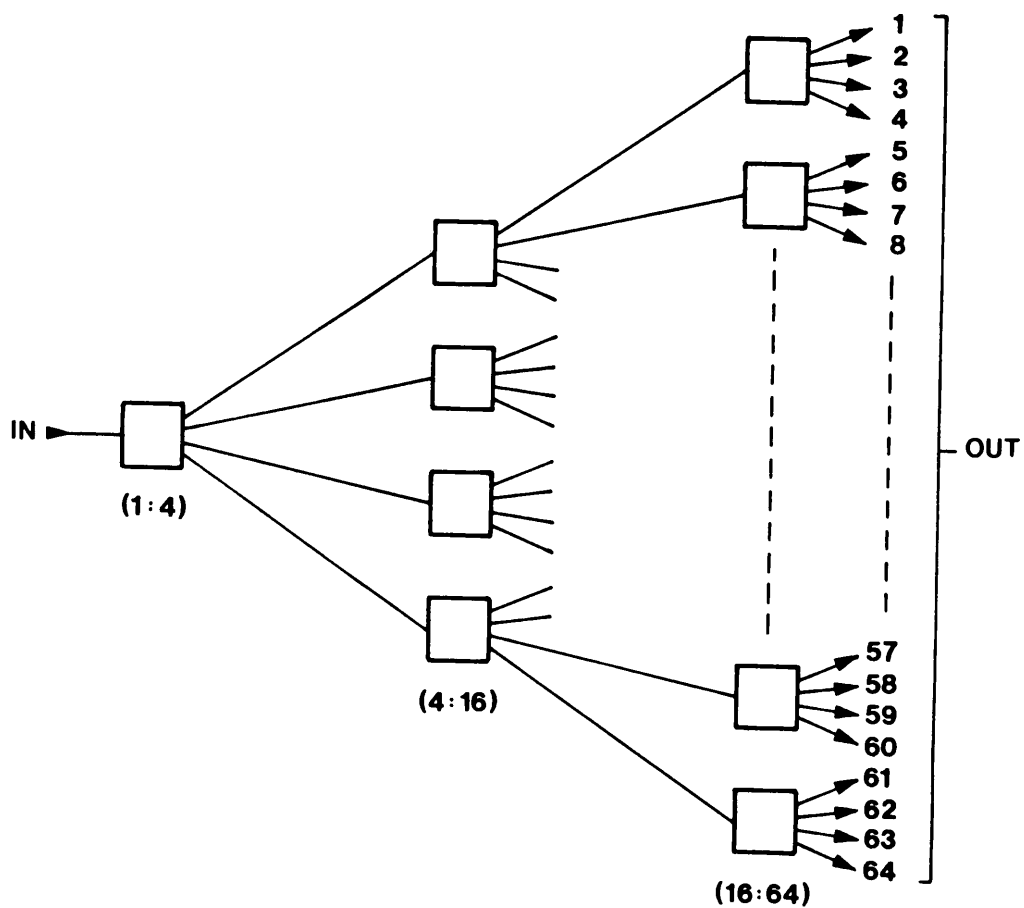
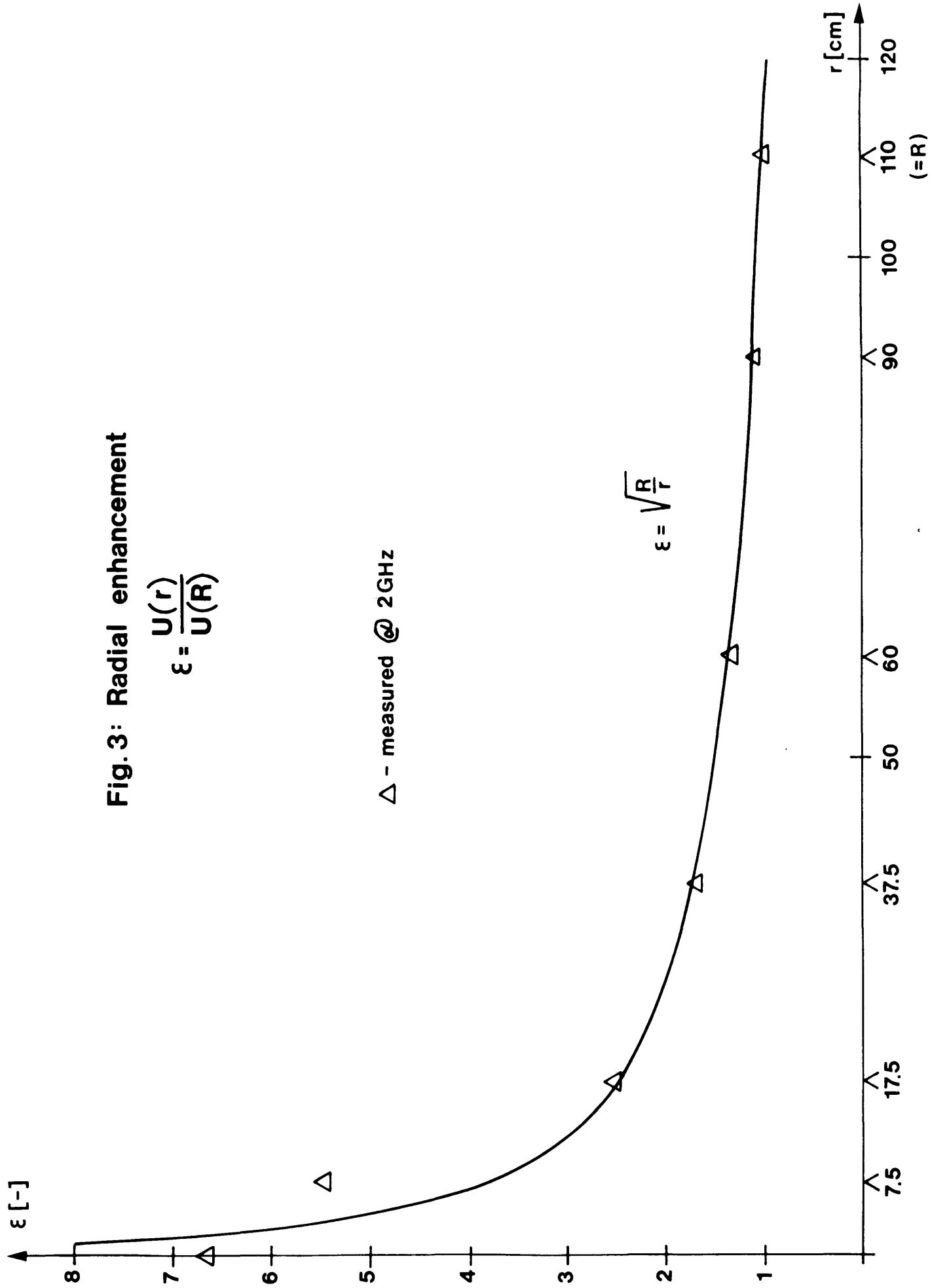

Fig. 2b: 1:64 Power divider network



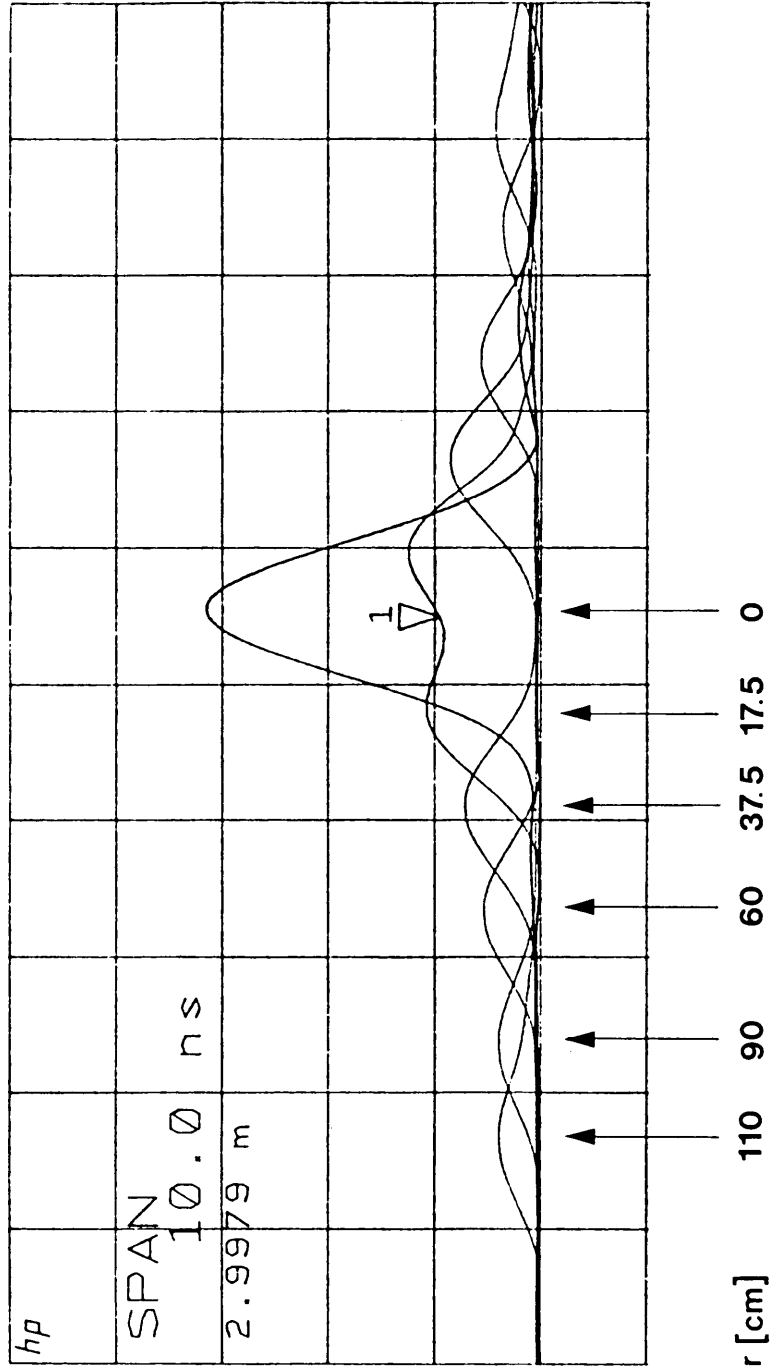

Fig.4: Pulses at different radii as measured with network analyzer

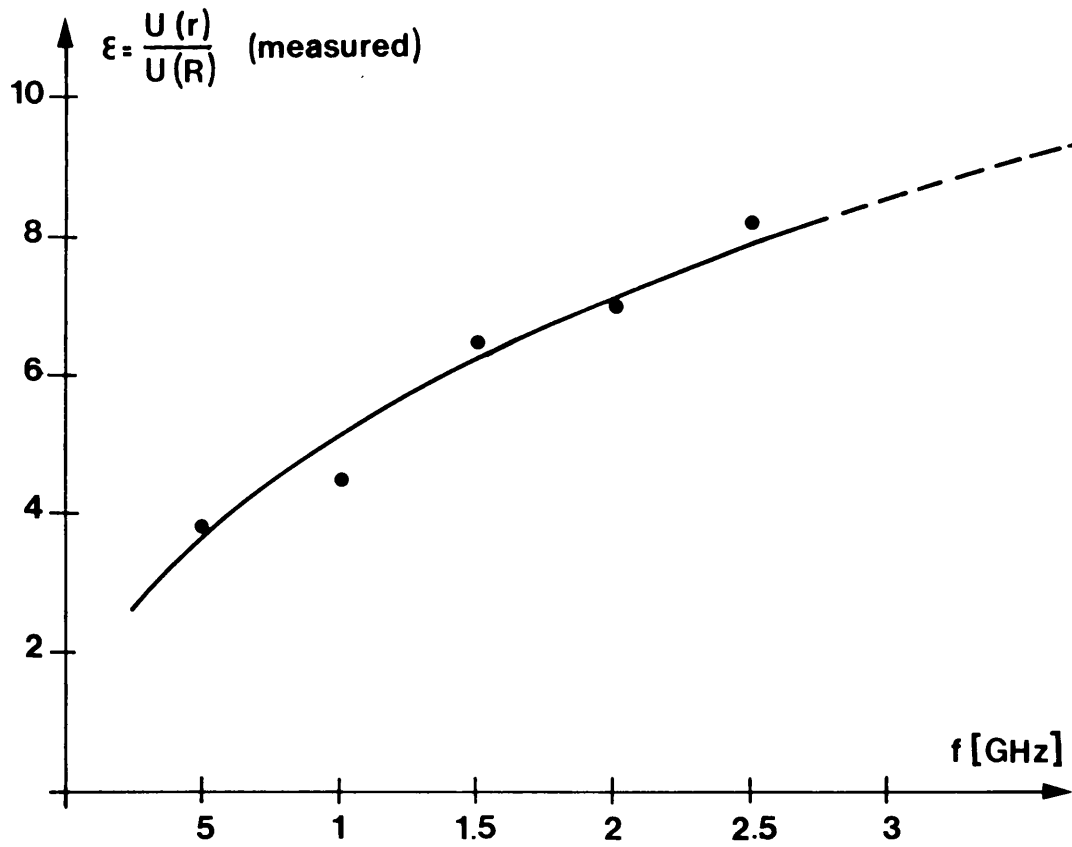

Fig. 5a: Enhancement vs. frequency

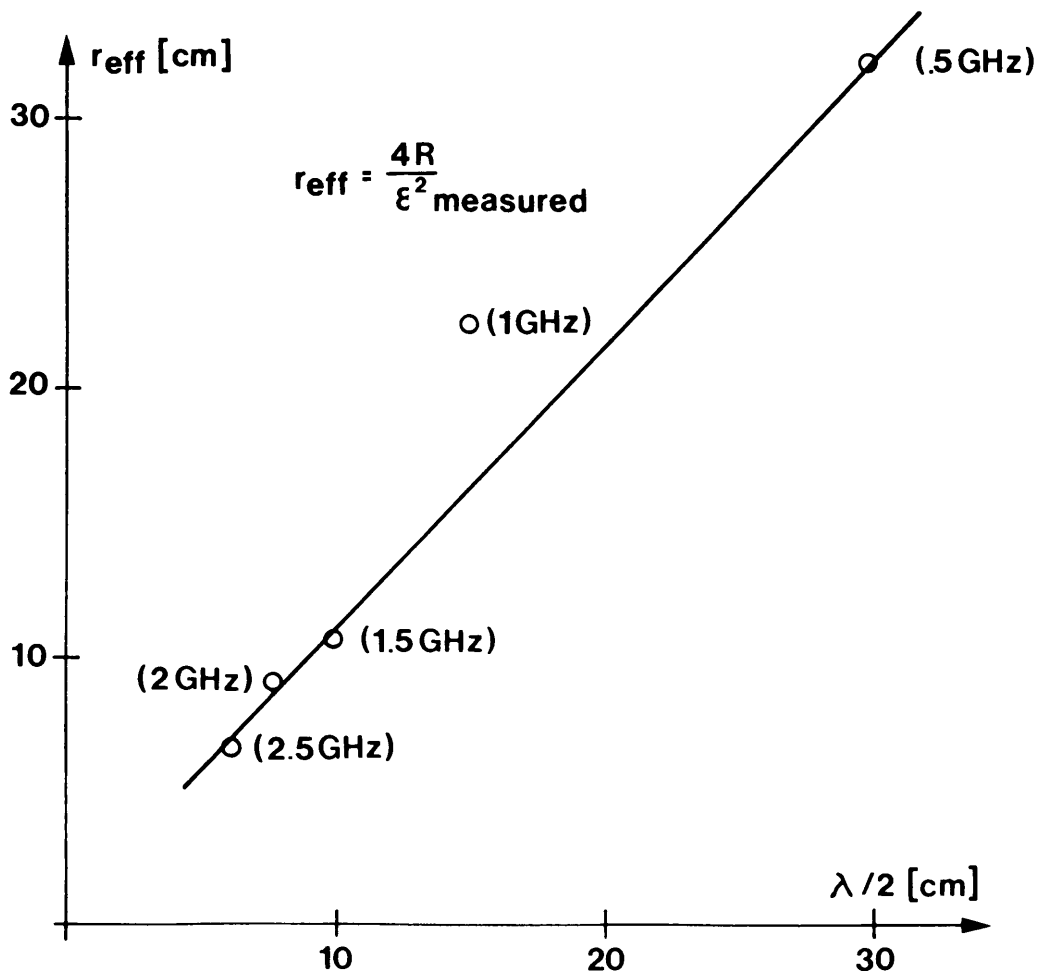

Fig. 5b: Effective radius (from $\epsilon(f)$) vs. wavelength

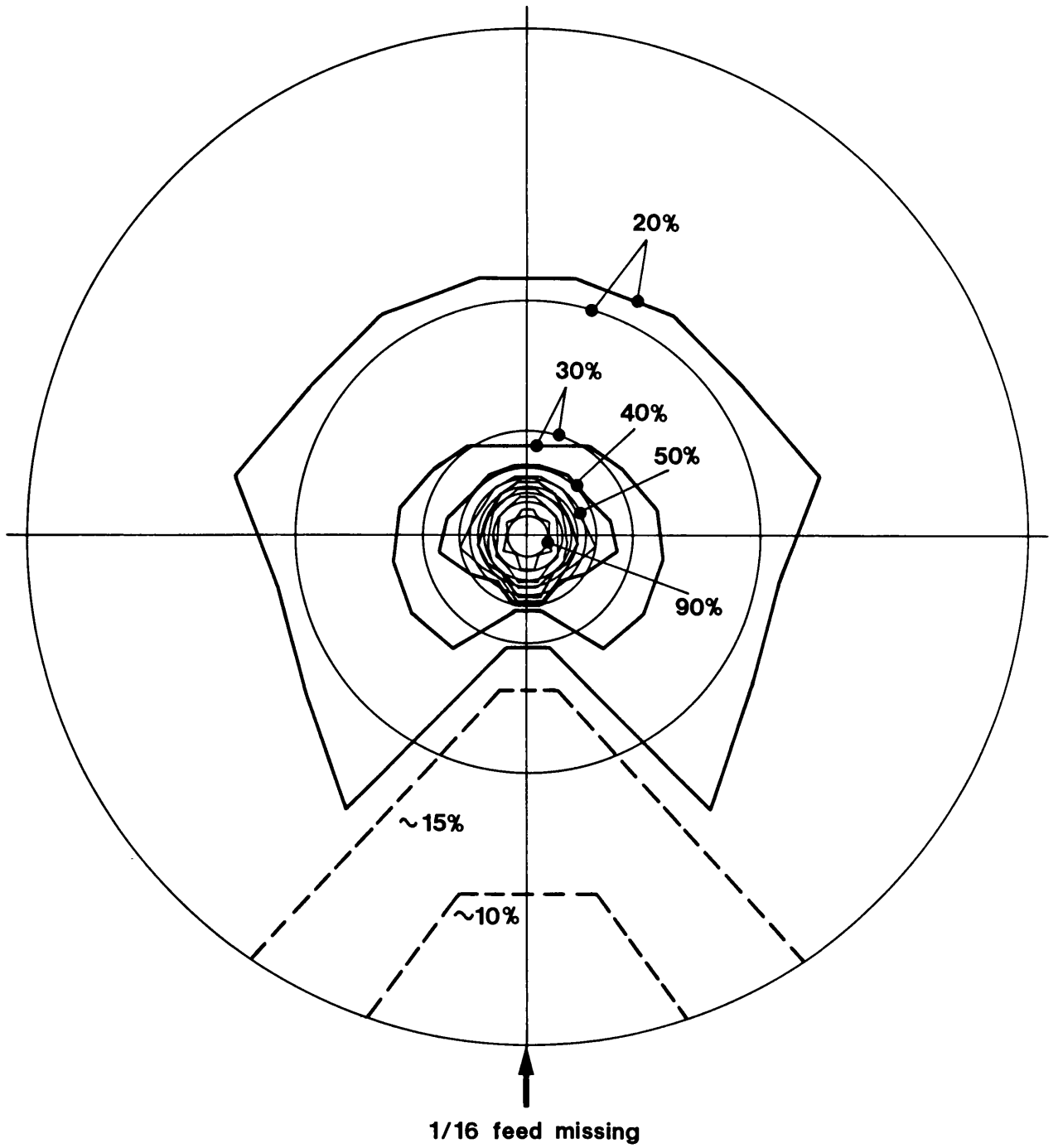

Fig.6: Equipotential plot for asymmetric feed