

CERN 62-37

Data Handling Division

28 December 1962

ORGANISATION EUROPÉENNE POUR LA RECHERCHE NUCLÉAIRE
CERN EUROPEAN ORGANIZATION FOR NUCLEAR RESEARCH

INFORMAL MEETING ON TRACK DATA PROCESSING

held at CERN
on 19th July, 1962

PROCEEDINGS

edited by

M. Benot
B. Elliott

G E N E V A

1962

© Copyright CERN, Genève, 1962

Propriété littéraire et scientifique réservée pour tous les pays du monde. Ce document ne peut être reproduit ou traduit en tout ou en partie sans l'autorisation écrite du Directeur général du CERN, titulaire du droit d'auteur. Dans les cas appropriés, et s'il s'agit d'utiliser le document à des fins non commerciales, cette autorisation sera volontiers accordée.

Le CERN ne revendique pas la propriété des inventions brevetables et dessins ou modèles susceptibles de dépôt qui pourraient être décrits dans le présent document; ceux-ci peuvent être librement utilisés par les instituts de recherche, les industriels et autres intéressés. Cependant, le CERN se réserve le droit de s'opposer à toute revendication qu'un usager pourrait faire de la propriété scientifique ou industrielle de toute invention et tout dessin ou modèle décrits dans le présent document.

Literary and scientific copyrights reserved in all countries of the world. This report, or any part of it, may not be reprinted or translated without written permission of the copyright holder, the Director-General of CERN. However, permission will be freely granted for appropriate non-commercial use.

If any patentable invention or registrable design is described in the report, CERN makes no claim to property rights in it but offers it for the free use of research institutions, manufacturers and others. CERN, however, may oppose any attempt by a user to claim any proprietary or patent rights in such inventions or designs as may be described in the present document.

CERN 62-37

Data Handling Division

28 December 1962

INFORMAL MEETING ON TRACK DATA PROCESSING

held at CERN
on 19th July, 1962

PROCEEDINGS

edited by

M. Benot
B. Elliott

G E N E V A

1962

TABLE OF CONTENTS

Time-table		iii
Foreword		1
I. MORNING SESSION (Chairman: L. Alvarez)		
Influence of ionization loss and coulomb scattering on the geometrical reconstruction of tracks in bubble chambers	R. Böck	5
A criterion for the goodness of measurements of tracks in hydrogen bubble chambers and how to measure the tracks in order to make it significant	E. Fett	11
DISCUSSION		15
The programming system used by the Alvarez Group	A.H. Rosenfeld	17
DISCUSSION		18
Magnetic field and energy-loss corrections for strongly curved tracks	J. Zoll	19
Programming at the Rutherford Laboratory	J.W. Burren	23
Programmes used at Moscow	S.Ya. Nikitin	25
DISCUSSION		26
Preliminary results on pattern recognition at Brookhaven	P.V.C. Hough	29
Future developments based on FSD	H. White	33
DISCUSSION		41
General considerations of the SMP	L. Alvarez	43

On-line aspects of SMP	J.N. Snyder	45
Results from the SMP	R. Hulsizer	49
DISCUSSION		50

II. AFTERNOON SESSION (Chairman: Y. Goldschmidt-Clermont)

Multiple slit rotating analyser	G. Brautti	55
A proposed rapid hand-operated digitizing apparatus for the measurement of track chamber photographs	O.R. Frisch	59
Digitized measuring projector for the analysis of spark chamber photographs	L.T. Kerth	65
A point position digitizer based on magnetic induction	R. Chase	67
DISCUSSION		68
Hardware development at the Rutherford Laboratory	B. Burren	71
"Chloe", A system for the automatic handling of spark pictures	J.W. Butler	73
A description of the PRU device	B.H. McCormick	81
A scheme for automatic processing of bubble chamber and spark chamber photographs	A.R. Edmonds	83
DISCUSSION		93
Concluding remarks	L. Kowarski	99
List of participants		101

INFORMAL MEETING ON TRACK DATA PROCESSING

I. Morning session (Chairman: L. Alvarez)

<u>Title of communication</u>	<u>Presented by:</u>	<u>Appears in these Proceedings as:</u> (see Foreword)
1. Influence of ionization loss and coulomb scattering on the geometrical reconstruction of tracks in bubble chambers.	R. Böck (CERN)	P
2. A criterion for the goodness of measurements of tracks in hydrogen bubble chambers and how to measure the tracks in order to make it significant.	E. Fett (CERN)	P
DISCUSSION		
3. The programming system used by the Alvarez Group.	A.H. Rosenfeld (Berkeley)	R
DISCUSSION		
4. Programmes written at Cambridge.	J. Zoll (Cambridge)	P
5. Programming at the Rutherford Laboratory.	B. Burren (Harwell)	S
6. Programmes used at Moscow.	S. Ya. Nikitin (Moscow)	S

DISCUSSION

<u>Title of communication</u>	<u>Presented by:</u>	<u>Appears in three Proceedings as:</u> (see Foreword)
7. Preliminary results on pattern recognition at Brookhaven.	P.V.C. Hough (Brookhaven)	P
8. Future developments based on FSD.	H. White (Berkeley)	P
DISCUSSION		
9. General considerations of the SMP.	L. Alvarez (Berkeley)	S
10. On-line aspects of SMP.	J.N. Snyder (Urbana, Ill.)	T
11. Results from the SMP.	R. Hulsizer (Berkeley)	R
DISCUSSION		
II. Afternoon session (Chairman: Y. Goldschmidt-Clermont)		
12. Multiple slit rotating analyser.	G. Brautti (Trieste)	P
13. A proposed rapid hand-operated digitizing apparatus for the measurement of track chamber photographs.	O.R. Frisch (Cambridge)	P
14. Digitized measuring projector for the analysis of spark chamber photographs.	L.T. Kerth (Berkeley)	R

<u>Title of communication</u>	<u>Presented by:</u>	<u>Appears in three Proceedings as:</u> (see Foreword)
15. A point position digitizer based on magnetic induction.	R. Chase (Brookhaven)	S
DISCUSSION		
16. Hardware developments at the Rutherford Laboratory.	B. Burren (Harwell)	S
17. A system for the automatic handling of spark pictures	J.W. Butler (Argonne)	P
18. A description of the PRU device.	B.H. McCormick (Urbana, Ill.)	R
19. A scheme for automatic processing of bubble chamber and spark chamber photographs	A.R. Edmonds (London)	P
DISCUSSION		
Concluding remarks	L. Kowarski (CERN)	

F O R E W O R D

The processing of the visual information contained in bubble-chamber and spark chamber photographs is an essential part of these detecting techniques, and the instruments needed for such processing are rapidly growing in importance. This growth presented the organizers of the 1962 Instrumentation Conference, held at CERN on July 16-18, with a problem which their immediate predecessors (at Berkeley, in 1960) had already had to face: how to provide an adequate discussion forum for this specialized subject while keeping a balanced view of its place in the instrumentation field as a whole. Following the Berkeley precedent, it was decided to supplement the sessions of the Conference devoted to data handling by an additional day of discussions, which would be open to all those specially interested in these techniques.

The meeting was organized, on informal lines, by the Data Handling Division of CERN (Dr. L. Kowarski acting for the Division as a whole, Mr. M. Bénot and Mr. B. Elliott as scientific secretaries, and Mrs. G. Andreossi as executive secretary).

Communications and discussions were invited on the three following topics:

1. Present state and prospects of semi-automatic devices for the processing of bubble pictures: the Hough-Powell system (CERN, Berkeley, Brookhaven and Harwell), the Scanning and Measuring Projector (Berkeley), the Precision Encoding and Pattern Recognition device (M.I.T.), etc.
2. Ideas and reports on similar devices for spark pictures.
3. New developments in programming for the systems currently used (digitizing projector) and for those about to be used.

In the course of the Meeting 19 communications were presented and many of them were followed by lively discussions. Since the Meeting was meant to be a discussion platform rather than a publication medium, and since the authors of communications were not bound by any formal rules, the accuracy with which individual communications could be reported in the present Proceedings had to depend on the efforts put in by their respective authors. Some of the speakers (not the majority) had prepared formal papers which could be presented in the usual way and were ready for inclusion in the Proceedings. One paper was written after the meeting. Other speakers based the presentation and the

subsequent discussion on papers which had been previously released as laboratory reports, or - a day or two before our Meeting - at the Instrumentation Conference: in these latter cases the presentation at the Meeting, with its freer timetable and more specialized audience, gave an opportunity for a more detailed treatment of the subject matter than was possible at the Conference. In a few cases the editors were left with no document other than a tape recording of the spoken communication and they made an attempt, under their own responsibility, to summarize its contents. Of the total volume of communications which were presented at the Meeting only about one-half appears here in a completely written-up form; the rest is represented by summaries, bibliographical references and discussions. (In the list of communications which immediately follows this Foreword, P stands for "submitted paper", R for "reference", S for "summary" and T for "condensed transcript").

The figures and pictures appear at the end of each corresponding paper and, although no captions were provided by the authors, the references and the context may be hoped to establish an unambiguous connection.

I. MORNING SESSION

Chairman: L. Alvarez

Influence of ionisation loss
and coulomb scattering on the geometrical
reconstruction of tracks in bubble chambers

R. Böck, S. Shapira

(CERN)

This paper describes results obtained by geometrical reconstruction of tracks created artificially by a programme, in simulating the behaviour of tracks in a bubble chamber.

1. The programme for artificial track construction (ATC) uses a number of parameters as starting information. Those are:

\vec{x}_0 = initial point co-ordinates

λ_0, ϕ_0 = initial dipping and azimuthal angles

P_0, m = initial momentum, particle mass

ΔL = step length for successive points (chosen to be 0.5 mm).

Furthermore, the quantities necessary to transform space co-ordinates into film co-ordinates, a range-energy table, a coulomb scattering constant K and a r.m.s. measurement error Δx are prescribed.

The results quoted below were obtained using the data for the Saclay 81 cm hydrogen bubble chamber with three cameras.

Tracks are constructed according to the following formulae, until a prescribed length L of the track has been constructed.

$$(1) \vec{x}_j = \vec{x}_{j-1} + \vec{\Delta}_j L + \vec{\Delta}_j^T$$

where: 1a) $\Delta_j^L = \Delta L$

$$\left\{ \begin{array}{l} \cos \lambda_{j-1} \cos \phi_{j-1} \\ \cos \lambda_{j-1} \sin \phi_{j-1} \\ \sin \lambda_{j-1} \end{array} \right.$$

$$1b) \vec{\Delta}_{\nu}^T = (\Delta L \cos \lambda_{\nu-1})^2 / 2\rho_{\nu-1} \begin{cases} -\sin \varphi_{\nu-1} \\ \cos \varphi_{\nu-1} \\ 0 \end{cases}$$

$$(2) \theta_{\nu} = N_{\nu} \frac{K}{\beta_{\nu} P_{\nu}} \sqrt{\Delta L} \quad (N_{\nu} = \text{random number out of a normal distribution with width} = 1)$$

$$(3) \alpha_{\nu} = S_{\nu} \quad (S_{\nu} = \text{random number between } 0 \text{ and } 1)$$

$$(4) P_{\nu} = PF/RF(P_{\nu-1}) - \Delta L \quad (PF, RF \text{ momentum} \leftrightarrow \text{range conversion})$$

$$(5) \lambda_{\nu} = \lambda_{\nu-1} + \theta_{\nu} \cos \alpha_{\nu}$$

$$(6) \varphi_{\nu} = \varphi_{\nu-1} + \theta_{\nu} \sin \alpha_{\nu} + \Delta L \cos \lambda_{\nu-1} / \rho_{\nu-1}$$

$$(7) \rho_{\nu} = P_{\nu} \cos \lambda_{\nu} / .3H$$

In these formulae \vec{X} represents the space co-ordinates for a point, λ and φ are the dip and azimuthal angles, $1/\rho$ is the projected curvature, ΔL the step length along the track and ν the step index. Further P = momentum, θ = scattering angle for a step (in space), K = scattering constant, β = velocity and α = random angle to give the direction of scattering in space.

2. This ATC programme was linked directly into the geometry programme used at CERN, the formulae of which are described in detail in CERN 60-33¹⁾. This programme uses the chamber geometry and the measured film co-ordinates to fit a helix in space, assuming approximately that Gaussian measurement errors have been made on the film.
3. To study the systematic influence of ionisation loss on the reconstructed results and to obtain corrections for them, the ATC programme was mainly used with $K = 0$ and $\Delta X = 0$, i.e. producing "ideal" trajectories.

The parameters varied were P_0 , M and L.

(a) Influence on the reconstructed curvature.

To study the $1/\rho$ resulting from the geometry programme the quantity L_ρ / L was plotted against L_ρ for equal sets of P_0 , M. L_ρ is defined as the length along the track between the starting point and the point at which the particle had a momentum corresponding to the reconstructed curvature. In the existing geometry and kinematics programmes this quantity L_ρ / L is assumed to be 0.5. The results for "ideal" trajectories showed that L_ρ / L can vary between .4 and .65 in a systematic way with generally two maxima, one of which is always reached when the "measured" length is equal to the range. The considerable deviations from $L_\rho / L = .5$ occur mainly for light particles and long tracks. The maximum error one can make with the assumption $L_\rho / L = .5$ was estimated to be $\Delta P/P = 2\%$ for the corrected P at the starting point of the track. In addition the results show (Fig. 1) that both measurement errors and coulomb scattering cause uncertainties for L_ρ / L which overrule by far the systematical deviations.

(b) Influence on the reconstructed azimuthal angle.

It is obvious that the helix assumption in the geometry programme also causes a systematic error in the azimuthal angle. Although this difference generally is within the uncertainty following from K and ΔX , its systematic behaviour could be studied by setting these influences zero. The differences between ϕ_0 and ϕ_R (reconstructed) at the starting point (particle travelling away) were found to be consistent (Fig. 2)

with

$$\Delta = \varphi_0 - \varphi_R = \pm .000135 \left(\frac{L}{R}\right)^2 \left(\frac{R}{M}\right)^{.75}$$

(R = range in cms, M in GeV, φ in radians)

The sign is positive for a track curved anti-clockwise.

4. (i) For the coulomb scattering the aim was to find a suitable formula to express the uncertainty of the reconstructed results. If one recalls the definition of an error matrix term $G_{ij}^{-1} = \overline{\sigma_i \sigma_j}$ it seems easy to find such a matrix. Each σ_i is defined with i, j referring respectively to $1/\rho$, λ , φ as the difference between the original quantity entered into the ATC-programme and its corresponding reconstructed result. To avoid systematic influences the energy loss was assumed to be zero in this investigation. All products $\sigma_i \sigma_j$ were formed in each event and averaged for a sample of events with exactly the same starting conditions. In order to get an uncertainty of $\sim 10\%$ for the diagonal elements of the average error matrix each sample had to comprise ~ 100 events. The average of each sample was regarded as the error matrix for the given starting conditions.
- (ii) To find a formula consistent with these results, the assumption was used that the expression for the average scattering angle holds for any distance L (i.e. this angle is proportional to \sqrt{L}) and that furthermore all actual points lie on the same side of the ideal particle trajectory. As this obviously leads to an overestimation of the actual influence, a constant factor must be expected. With these assumptions the expected behaviour is (apart from the influences of the number of measured points, which is within $\pm 5\%$)

$$\sigma_{1/\rho} = c_{\varphi} \frac{f}{\sqrt{L}}$$

$$\sigma_{\lambda} = c_{\lambda} f \sqrt{L}$$

$$= c_{\varphi} f \sqrt{L}$$

where $f = \frac{K}{\beta p}$

- (iii) The matrices obtained by the ATC programme were consistent with these formulae and no systematic behaviour of the coefficients, C, could be observed.

The average values are:

$$c_{\rho} = 0.39 \quad c_{\lambda} = 0.50 \quad c_{\varphi} = 0.38$$

each obtained with an accuracy of $\sim \pm 3\%$ from 50 different starting conditions.

In addition the non-diagonal terms in the error matrix were looked at. The only element which turned out to be not zero within the fluctuation inherent to the method was

$\overline{\sigma_{1/\rho} \sigma_{\varphi}}$. After normalisation this term seemed to be constant and was averaged to give

$$\frac{\overline{\sigma_{1/\rho} \sigma_{\varphi}}}{\sigma_{1/\rho} \sigma_{\varphi}} = - .31$$

No influence of these results from the dip angle λ was studied, all numbers given refer to $\lambda = 0$.

- 1) W.G. Moorhead, "Programme for the Geometrical Reconstruction of Curved Tracks in a Bubble Chamber", CERN 60-33.

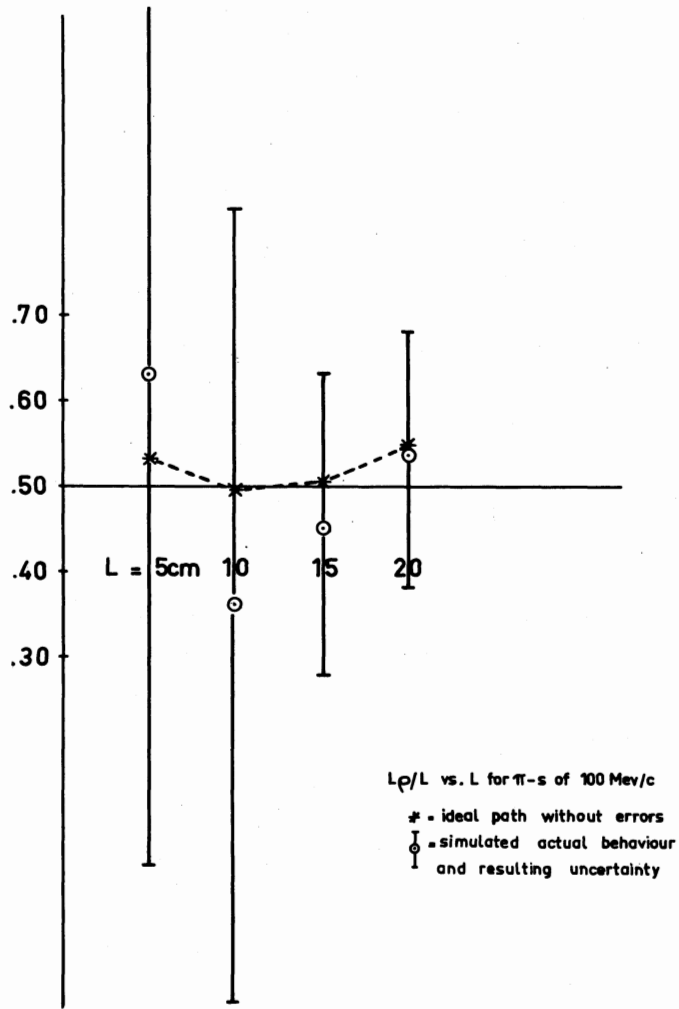

Figure 1

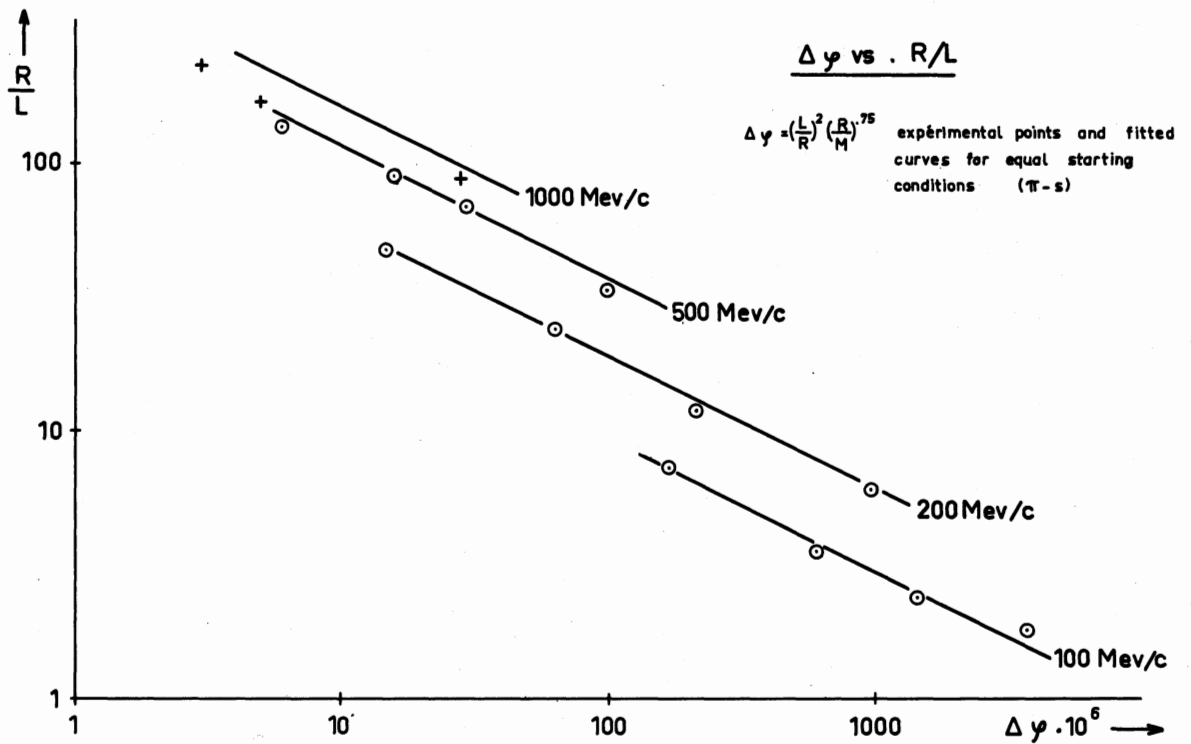

Figure 2

A criterion for the goodness of measurements of tracks
in hydrogen bubble chambers, and how to measure the
tracks in order to make it significant

E. Fett (CERN)

1. Introduction

It is wellknown that the Geometry Programme used by CERN fits a helix to the measurements of tracks from hydrogen bubble chambers. The helix is defined by the radius of curvature, dip angle, azimuthal angle and the co-ordinates of the starting point. The errors were calculated in the least squares procedure using the fact that each measurement gives rise to one linear equation and these equations are assumed to have the same weight.

The new Geometry Programme, THRESH, will calculate the errors in a different manner. THRESH assumes that each co-ordinate given by the measuring device has a wellknown and constant error δ , and the error matrix is found using the method of propagation of errors. In other words: THRESH assumes that the measurements are good, or at least normal. This paper suggests a way of testing this assumption for each single measured track.

2. Description

Let us, as a first approximation, assume that the actual track and the fitted helix are identical. The true measure for the goodness of measurements would then be the spread of the measured points (on the film-views) along the reprojections of the fitted helix on these film-planes. Thus if the distance from a measured point P_i to the reprojected curve is D_i , we may define.

$$S^2 = \frac{1}{N} \sum_{i=1}^N D_i^2$$

where N is the number of all measured points.

3. Significance

Unfortunately the actual track and the fitted helix are not quite identical, therefore S^2 will not be zero even if you have a 100% efficient measuring device. Due to multiple scatter we will have a mean effect \bar{S}_1^2 (where we average over all tracks of particles with the same starting condition). If we have normal measurement errors, and if the effects are uncorrelated, the mean of S^2 will be

$$\bar{S}^2 = S_1^2 + \delta^2 + S_2^2$$

where S_2^2 is due to energy loss and systematic distortion. Thus S^2 will be significant as a measure for the goodness of measurements only if $S_1^2 + S_2^2 \ll \delta^2$. For IEP 5 we have $\delta \sim 70 \mu$ (in space). Therefore in order to know the significance of the S^2 test we must know the contributions of S_1^2 and S_2^2 for different particles, momenta and measured lengths.

4. Multiple scattering

Let me first discuss the influence of multiple scattering. Figure 1 shows S_1^2 for Υ -mesons of four different momenta as function of the measured length. It shows that the influence increases enormously if a larger part of the track is measured, especially for "slow" tracks. The obvious conclusion is that the S^2 - test is

meaningless if we measure a larger fraction of "slow" tracks, whereas we have no trouble of that kind for fast tracks. The question is, consequently, whether we should measure a smaller part of "slow" tracks, for instance 7 cm only of a 100 MeV/c pion although the range is 34 cm (in hydrogen). To answer this question we have to know what we lose or gain in accuracy of the other parameters. I have used a programme written by R. Böck¹⁾ to create artificially tracks of particles with specified starting conditions. 100 tracks are created for each set of starting conditions and the spread of each parameter is studied.

Figure 2 shows $\Delta (1/\rho) / (1/\rho)$ ($\rho =$ radius of curvature) corresponding to the curves in figure 1. One sees that for a 100 MeV/c pion the uncertainty is 5.5% if we measure 7 cm, whereas 2.5% only if we measure 34 cm. Figure 3 shows the corresponding curves for the uncertainty of the dip: $\tan \alpha$. One sees that one gains accuracy if one measures a smaller fraction of the track. The corresponding curves for the uncertainty of the azimuthal angle look very similar to those in figure 3.

Another point is that it is very difficult to have a "slow" track converging in the Geometry Programme if one measures a large fraction. Therefore the dotted curves are just extrapolations.

5. Other contributions

Using the same procedure I have found that for the "slow" tracks in question, the contribution due to multiple scatter and its dependence of the measured length is the dominant factor both for S^2 and for the uncertainties of the parameters. I have always found that $S_2^2 \ll S_1^2$ if I use data from the 81 cm hydrogen bubble chamber of Saclay; further the measurement errors of IEP 5 do not change the essential features of the curves in figures 2 and 3 except for measured lengths less than 7 cm. The influence of the number of points measured is negligible.

6. Conclusions

Thus we can sum up the arguments as follows:

ARGUMENTS

for

measuring

Shorter parts of "slow" tracks

As long as possible

- | | |
|---|-------------------------------|
| 1. To make the S^2 test significant | 1. To gain accuracy in ρ |
| 2. To avoid a large fraction of non-converging tracks | |
| 3. To gain accuracy in $\tan\alpha$ | |
| 4. To gain accuracy in β | |

It seems to me that it is desirable even for "slow" tracks to measure in a manner which makes the S^2 test significant.

7. Test of real tracks

If, now, real tracks are measured in a manner which makes the S^2 test significant we expect the distribution of S^2 to have a similar shape to the χ^2 distribution, but with a rather long tail corresponding to bad measurements. Figure 4 shows the distribution for 649 tracks of pions all of momenta less than 3 GeV/c. While measuring these tracks no attention was paid to the length being measured. Therefore, in this case S_1^2 and S_2^2 may be important, thus making $S^2 > \delta^2$. However, the tendency is still clear.

The work with real tracks will go on, also different machines and operators will be compared.

- 1) R. Böck, "Influence of ionization loss and coulomb scattering on the geometrical reconstruction of tracks in bubble chambers".

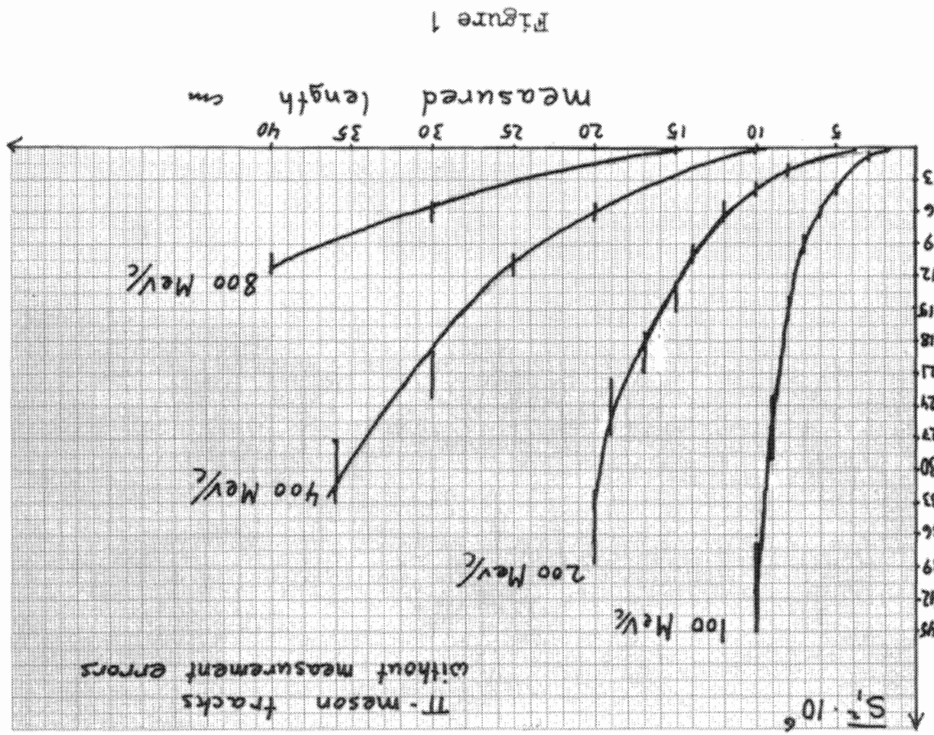
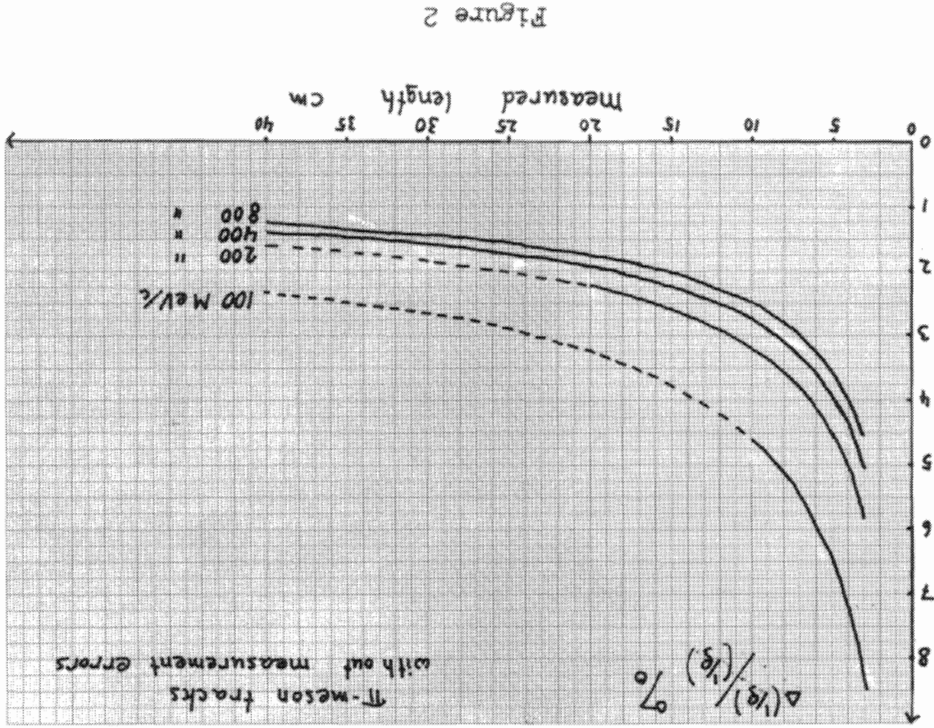

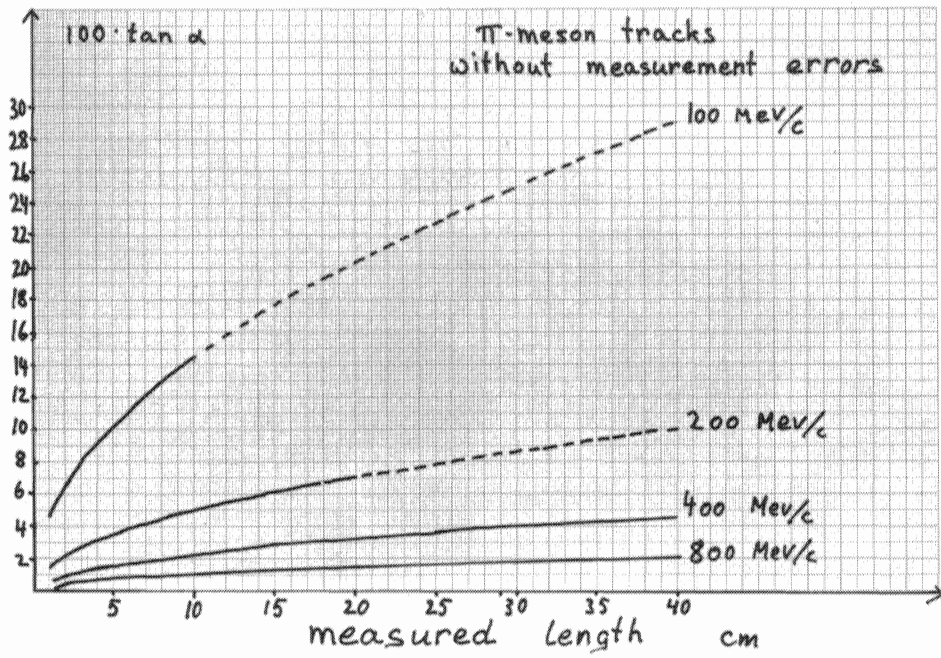

Figure 3

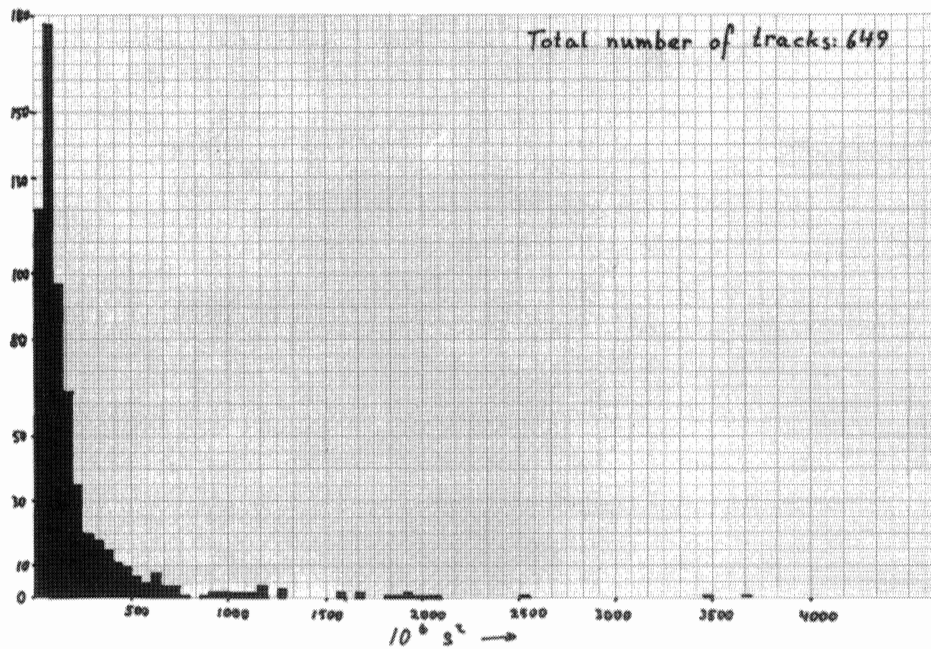

Figure 4

DISCUSSION

(Communications 1 and 2)

ALVAREZ: You can never gain by not measuring something, so you should always measure the longest length possible. Then, perhaps, you can use a small segment of the measured track to get the angle and the long segment of the track to get the momentum.

FETT: My suggestion of not measuring all the track is mainly relevant for a good angular result and to avoid difficulties in reconstruction by too large deviation from a helix. You can, of course, measure the full track and just use the optimum length for the reconstruction. Thus my results confirm the procedure which is in the Fog programme.

ROSENFELD: Did you find any sort of correlation at the middle of the track?

BOCK: In our geometry programme we do not get any data in the middle of the track so we did not study that. Out of the geometry programme we come with a fitted set of data - curvature and two angles - which belong to the beginning of the track.

TYCKO: Was the magnetic field in your ATC uniform?

BOCK: Our magnetic field was assumed constant in this test. In our present experiments, the variation is rather small compared to all other influences; it could be studied with the same programme, of course.

SELOVE: When you generate tracks, can you say something about the influence of the mesh size? You said you used 1/2 mm steps.

BOCK: We have not studied this seriously. I made a short test on this in doubling the step size and the results were exactly the same.

DERRICK: (Made a comment which is amplified in the Proceedings of the Conference on Instrumentation in a paper by C.J.B. Hawkins).

The programming system used by
the Alvarez Group

A.H. Rosenfeld, (Berkeley)

(Note by the editors: a paper on this subject was submitted to the Instrumentation Conference, held at CERN on July 16 - 18 and is included in the Proceedings of that Conference, to be published shortly in "Nuclear Instruments and Methods". The Informal Meeting of July 19 offered the author the opportunity for a more detailed presentation and discussion).

DISCUSSION

(Communication 3)

MCCORMICK: Have you done anything about trying to get rid of your bias by looking at the actual signs of the corrections in your χ^2 fit. In other words, looking at how many standard deviations each of the variables shift to see whether they systematically move in one way.

ROSENFELD: I think the reason that less work has been done, and that nobody worried about it, . . . is that on every experiment we make three sets of plots - we always plot our χ^2 's - which incidentally turn out usually to be too large by only something like 20% to 30%. When we calculate errors, then - mass errors - we assume, in the simplest way, that all errors are too large by $\sqrt{1.3}$, and so we scale everything by $\sqrt{1.3}$. But it seems not to be terribly serious. Then we plot also the fault markers, which are how much the individual momenta are displaced, and we have never found anything seriously systematic.

MACLEOD: Can you explain to me how the time-sharing in Q^* is operated?

ROSENFELD: It is done in the most simple way. We let Q^* have control with ten words or so and as soon as it is through and written "Control", it simply reads itself out of core and reads in whatever else is running under FORTRAN monitor and that churns away until we are ready to go again, so it is not very elegant and on each switch we waste 2 seconds.

Magnetic field and energy-loss corrections
for strongly curved tracks

J. Zoll (Cambridge)

This paper presents a new solution to the problem of correcting for an inhomogeneous magnetic field and the energy-loss of particles in the bubble chamber. The spirit and context of this solution is a PANG-type approach to the reconstruction of the tracks in space.

Take two stereoscopic photographs of a track and measure a series of points on each; find by the usual methods a string of space-points on the track.

First approximation: Fit an ideal helix (circle and straight line) to these points in cartesian coordinates. This gives a "center" of the track and a first approximation momentum (which may be improved for slow tracks¹⁾). Convert the cartesian co-ordinates (xyz) into cylinder co-ordinates (r ϕ z) with origin in the "center", $\phi = 0$ for the middle of the track.

Second approximation: We wish to fit a new helix.

$$r = \alpha_0 + \alpha_1\phi + \alpha_2\phi^2 + \alpha_3\phi^3 + \alpha_4\phi^4 = \sum_i \alpha_i \phi^i \quad (1)$$

$$z = \beta_0 + \beta_1\phi + \beta_2\phi^2 + \beta_3\phi^3 + \beta_4\phi^4 = \sum_i \beta_i \phi^i$$

For an ideal helix, the coefficients for $i = 2, 3, 4$ would be zero; for the track we want to calculate them, using our knowledge of the magnetic field and the momentum-loss.

Here are first some formulae in cylindrical co-ordinates which we shall need:

a point: $\vec{r}(\phi) = \begin{pmatrix} r(\phi) \\ 0 \\ z(\phi) \end{pmatrix}$

derivative: $\vec{r}' = \frac{d\vec{r}}{d\phi} = \begin{pmatrix} r' \\ r \\ z' \end{pmatrix}$; ($r' = \frac{dr}{d\phi}$ etc.) (2)

unit tangent-vector: $\vec{n} = \frac{d\vec{r}}{ds} = F \vec{r}'$ (3)

$F = (r^2 + r'^2 + z'^2)^{-1/2} \approx \frac{\cos \lambda}{r}$ (λ =dip angle) (4)

magnetic field: $B = \begin{pmatrix} B_r \\ B(\phi) \\ B_z \end{pmatrix}$, units: MeV/c cm⁻¹ (5)

The curvature vector is $\vec{n} \times \frac{d\vec{n}}{ds}$ (6)

its z-component is proportional to the curvature in the (xy) or (rφ) plane.

The equation of motion of the particle is

$p \frac{d\vec{n}}{ds} = \vec{n} \times e\vec{B}$ (7)

p is the momentum; the line-element ds is taken positive in the positive sense of rotation; e = ±1 the charge, = ±1 for tracks turning like right - or left-handed screws.

Consider figure 1: this is a drawing of a segment of the track, projected onto the xy-plane. \vec{t} is its 2-dimensional tangent-vector. Through the point (r/φ) of projected track is drawn the circle r round

the origin and also its tangent \vec{n}_ϕ .

ψ , the azimuthal angle of the projected tangent t is:

$$\psi = \phi + \frac{\eta}{2} - \eta \quad (8)$$

Here η is the angle between the track and \vec{n}_ϕ . This angle specified the deviation of the track from an exact helix. η is small, and this is the point of the whole approach, as will be obvious in a minute. Except for a factor we get the curvature:

$$\begin{aligned} \frac{d\psi}{d\phi} &= 1 - \frac{d\eta}{d\phi} \quad \text{from (8)} \\ &= \frac{G^2}{F^3} (\vec{n} \times \frac{d\vec{n}}{ds})_z \quad \text{cf. (6)} \end{aligned} \quad (9)$$

$$= \frac{e \in G^2}{pF^3} [\vec{n} \times (\vec{n} \times \vec{B})]_z \quad (7)$$

$G = (r^2 + r'^2)^{-1/2}$; the factor G^2/F^3 follows from some algebra. Writing (9) in components and re-shuffling gives

$$\eta'(\phi) = \frac{d\eta}{d\phi} = 1 + \frac{e \in B_z}{pF} - \frac{e \in G^2 z}{pF} (r'_B r + rB_\phi) \quad (10)$$

For the ideal helix the first two terms would cancel; the third term would be zero, it results from the inhomogeneous field,

Proceed further as in PANG: take three representative points on the track, e.g. $\phi = 0$ the center, ϕ_- and ϕ_+ downstream and upstream, and calculate $\eta'(\phi_-)$, $\eta'(0)$ and $\eta'(\phi_+)$ using the momentum-range relation and the magnetic field. Fit a quadratic function

$$\eta'(\phi) = \gamma_0 + \gamma_1 \phi + \gamma_2 \phi^2 \quad (11)$$

and integrate to get

$$\eta = \eta_0 + \gamma_0 \phi + \frac{1}{2} \gamma_1 \phi^2 + \frac{1}{3} \gamma_2 \phi^3 \quad (12)$$

From the definition of η and (2)

We have $\frac{r'}{r} = \tan \eta = \eta$ to a very good approximation.

Since r varies little we may take the average value r_0 of the first approximation and write

$$r' = r_0 \eta = r_0 \eta_0 + r_0 \gamma_0 \phi + \frac{r_0}{2} \gamma_1 \phi^2 + \frac{r_0}{3} \gamma_2 \phi^3 \quad (13)$$

which when integrated gives (1) with

$$\alpha_2 = \frac{1}{2} r_0 \gamma_0 \quad (14)$$

$$\alpha_3 = \frac{1}{6} r_0 \gamma_1 : \alpha_4 = \frac{r_0}{12} \gamma_2$$

A least-squares fit to the data gives us the coefficients α_0 and α_1 . The polynomial (1) in Z may be obtained in the same manner by using the expression

$$Z'' = \frac{e \epsilon G^2}{p^2} (r' B_\phi - r B_r) + r' z' G^2 (r + r'') \quad (15)$$

which may be derived directly from the equation of motion (8). From the two expression (1) momenta and angles are easily obtained.

1) F. Solmitz, "Modifications of fitting procedures", Berkeley Memo 220.

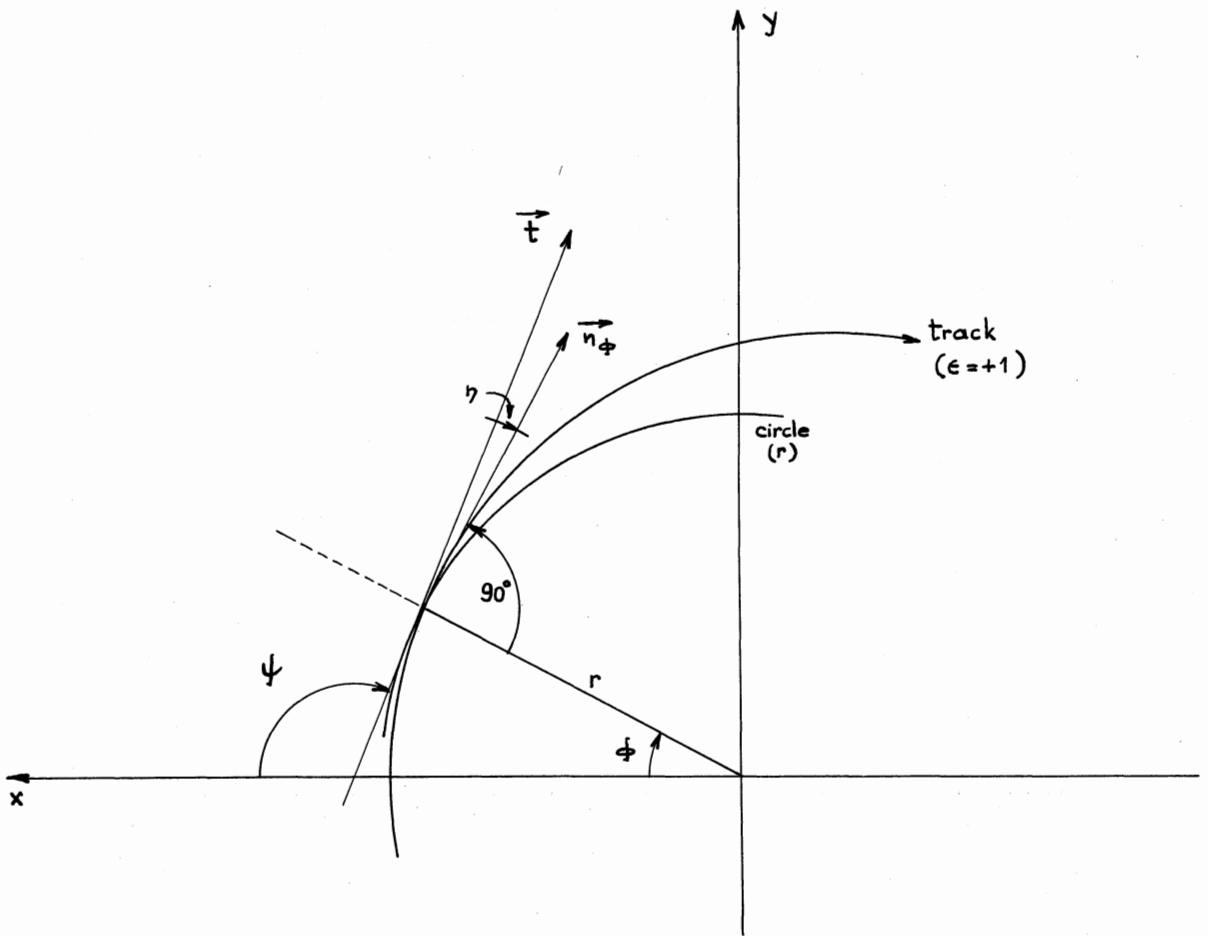

Figure 1

Programming at the Rutherford Laboratory

J.W. Burren
(Rutherford Laboratory)

SUMMARY

Dr. Burren explained that the N.I.R.N.S. programmes were divided into three parts:

a) An input programme to give a standard output onto magnetic tape from a number of different measuring machines.

b) A geometry programme using the PANG first fit, and the Solmitz helix-fitting method. This first used a K mass, and then for long tracks a π and p mass for slowing down. The output was used as a library tape.

c) A hypothesis testing and statistics routine, which up-dated the library tape with fitting results and gave a printed output. A hypothesis was specified by labelling a track at beginning and end, and by giving it a charge and mass. When all tracks had been specified, the programme tried to fit the pattern to the event, in the sequence specified (for a multi-vertex fit).

The first version had been used at Oxford and Padova, and was in the production-debugging stage.

Programmes used at Moscow

S. Ya. Nikitin

(Academy of Science, Moscow)

SUMMARY

Dr. Nikitin indicated that in Russia, general trends in programming were very similar to those which had already been described by other laboratories. The main effort at present was being directed towards the development of the filtering programme for the Moscow flying-spot device.

DISCUSSION

(Communications 4, 5 and 6)

ZOLL; Are you supposed to type the table of mass assignments on a tape, or does the computer generate this tape?

BURREN: No, you just type the hypothesis on a card and specify for which reel of tape or between which event numbers you wanted to try that hypothesis; or else you type half a dozen cards because you usually want to test more than one hypothesis at a time.

HULSIZER: Could you give us an idea of what it cost to write those programmes in FORTRAN, with respect to speed and memory load.

BURREN: We started writing the hypothesis-testing programme last June and we actually used the fitting part of it before Christmas, and the hypothesis programme in May or June for the first time. The geometry we started only about November and actually for production purposes the helix-fitting is not yet in, but it has worked - I think it is probably the first time F. Solmitz' method has been programmed. That is still going on, and is just about finished now.

As to the size of programme, the hypothesis-testing programme at the moment takes 13,000 IBM instructions and 13,000 words of store, but this is probably reducible by, at least 5,000, probably 10,000. When the fitting programme was written, we did not know how we were going to write the hypothesis programme and at the moment we have to do a rather messy dump in-between to get the data from one form into the other, so probably 5 to 10,000 can be saved on that quite easily.

The geometry is about 4,000 words of store and about 10 - 12,000 words of programme.

MACLEOD: Could you explain a little how the masses are introduced into your programme or am I mistaken in understanding the programme does make a mass-dependent fit to the tracks?

ZOLL: Well this is a bit complicated. We are using a coding system and a special kind of measuring procedure, where you measure first all the tracks which belong to one vertex or subsidiary vertex. You punch a code after the last track and this tells the computer what possible hypothesis to use, for any one of these tracks and code runs, along with the tracks specifying on binary digits which mass assignments need to be used. The mass-independent fit is calculated, then the mass-dependent iterations are performed before writing the results for each track.

POWELL: Could you say a few words about the FSD device to which you have just referred?

NIKITIN: It is being built mostly on the lines of your machine. I can give you some details about it, perhaps, but the overall design is very near to that you have.

Preliminary results on pattern recognition
at Brookhaven

P.V.C. Hough, (Brookhaven)

Over the past couple of years a number of us have been working on improvements in methods for measuring bubble chamber photographs. A challenging statement of goal by Prof. Alvarez was a million events per year. Essentially equivalent to this goal and challenging too, is an aim to extract the scientific content of the fraction of bubble chamber pictures produced at a large accelerator which any single large group might aspire to analyze. Presently developing systems, whether FSD or SMP, plan to accomplish this by multiplexing the human scanning function while automating the measuring function.

To introduce some specific numbers, the AGS at Brookhaven may be expected to produce some five million triads of photographs of one chamber or another each year. The bubble chamber group at Brookhaven might aspire to analyze half this number. Let me assume that our measuring and computing systems will be able to handle all events from this sample so as to focus attention on scanning. Then if you will accept 1 minute scanning time per triad and 500 minutes per shift (or 125, 000 minutes per shift per working year) ten human scanners can scan $1.1/4$ million triads per year per shift or the full $2.1/2$ million triads in two shifts. The bubble chamber group must hire some 30 scanners to man the two shifts. This plan of operation is in fact about that visualised at Brookhaven, but the cost and perhaps especially the organizational problems are considerable, so we are led to ask whether machines can help out on the scanning function as well.

In addition to this bubble chamber logistics motivation, I feel it is reasonable to add the motivation of the intrinsic interest of the problem, and, as Prof. McCormick has mentioned, the usefulness of any concrete results for other areas of visual data processing.

Prof. J. Pasta of Illinois spent the Summer of 1961 at Brookhaven, and with the aid of W.J. Beard set up some specific programming attacks on the problem of track-element recognition by means of a 7090 computer which read raw co-ordinate data from an HPD. They were joined in late fall by B. Marr and G. Rabinowitz, and recently by B. Wereser.

This group has accomplished two things which have aroused our interest and which are leading us to consider seriously whether the HPD is a suitable input device for computer scanning as well as measuring.

The first is this. By the Spring, various combinations of the first four people mentioned had produced working programmes of rather similar nature and performance. These programmes were tested using binary tapes of raw HPD co-ordinates from the CERN prototype, especially a set of 20 photographs of the BNL 20" chamber which were digitized at CERN last December by B.W. Powell and R. Palmer. The 20 photographs are from the K excitation experiment of Samios et al., and were selected to contain real and false two-prongs in situations of varying complexity. There were 10,000 to 20,000 co-ordinates per picture. As a specific example, a programme of G. Rabinowitz linked individual co-ordinates into track elements using only the criterion of "nearness" - i.e. points were associated into elements in their lateral co-ordinates were nearly enough the same on adjacent or nearly adjacent scan lines. The programme processed about 3,500 co-ordinates per second. No point was ever lost, and the results of a pass through the programme was a collection of "track-element" tables consisting of elements with say 6 or more linked points and a residue of "unrecognized" data.

Figure 1 shows the original data from one of the 20 pictures; figure 2 shows the "recognized" portion and figure 3 the residue. Typically,

10% of the original data make up the residue. While you can see some tracks in the residue, in all cases these tracks appear also in the recognised portion, so a further pass of the residue for association with established tracks would we believe leave just a noise pattern.

Going back to figure 2, two defects of the recognition process are lost in this plot and need to be emphasised. A particular track-element table fairly often contains pieces of two crossing tracks and so is tabulated as an erroneous track-element with a kink. Secondly, the computer plot has put back together all the track-elements forming a track-segment, whereas they are just separate tables in the computer. Nevertheless we are quite encouraged by the degree of success of a programme using such a single criterion for linking points.

The second result of the group was the discovery of tight programme loops which would perform linking operations while processing 15,000 co-ordinates per second. B. Marr and G. Rabinowitz in particular have been writing a programme using these tight loops over the past couple of months and it is expected to get its first trials in August. The new programme initiates over an area of perhaps 10% of the picture at the beam-entry end, using only the nearness criterion as before. It then "track-follows", i.e. links new points by look-ahead with a current slope, for all the track-elements found in the initiation phase. As the analysis wave passes down the picture new points which do not join to existing tracks are used in continuing attempts at initiation. Well-established tracks are collapsed into master-points which are 16-point averages so the whole picture will fit into the core store. Again, no points are ever thrown away, so the residue can be studied visually and can be subjected to further passes.

Now, suppose this does some good, or even suppose it works very well, there remains the problem of event recognition, assuming that good track tables have been prepared. I think everyone agrees that while this is

expected to be a very interesting problem and perhaps tricky, it will not require appreciable computing time in comparison with the first phase.

Let's continue, and suppose that event recognition works well and ask whether our auto-scan system will over-all be useful. As a specific optimistic example, suppose 2 seconds 7090 computing time are required for two stereo views and 1 second for the third, then our system scans 12 triads per minute and by our earlier convention equals 12 human scanners. On around-the-clock operation we get 36 scanner-shifts. The 80" chamber film will go about $2\frac{1}{2}$ times slower, but the 7094 gets us back a factor $1\frac{1}{2}$. We end up in this optimistic guessing game with one 7094 providing us with about our required 20 scanner shifts per day to scan our $2\frac{1}{2}$ million triads of 80" chamber film.

Whether such a procedure is economically justified seems doubtful. However, specific circumstances may alter the economics. For example, if a 7094 is owned and not yet saturated around the clock, a great deal of 20" chamber film could be scanned on an "owl shift". If a CDC 6600 existed, and it were 10 times faster than a 7094, and a laboratory had one it would seem reasonable to devote a few hours per day of it to scanning all the bubble chamber films. Finally, one of the fast small computers now becoming available may be suitable for the very elementary arithmetic operations used in the first and most time-consuming part of the pattern recognition programme. One of our most general and most basic reasons for preferring digital pattern recognition to analogue recognition (say of the Pless type) was the desire to be carried along by advances in the computer arts once our basic techniques were established. These are some specific examples of how this might occur.

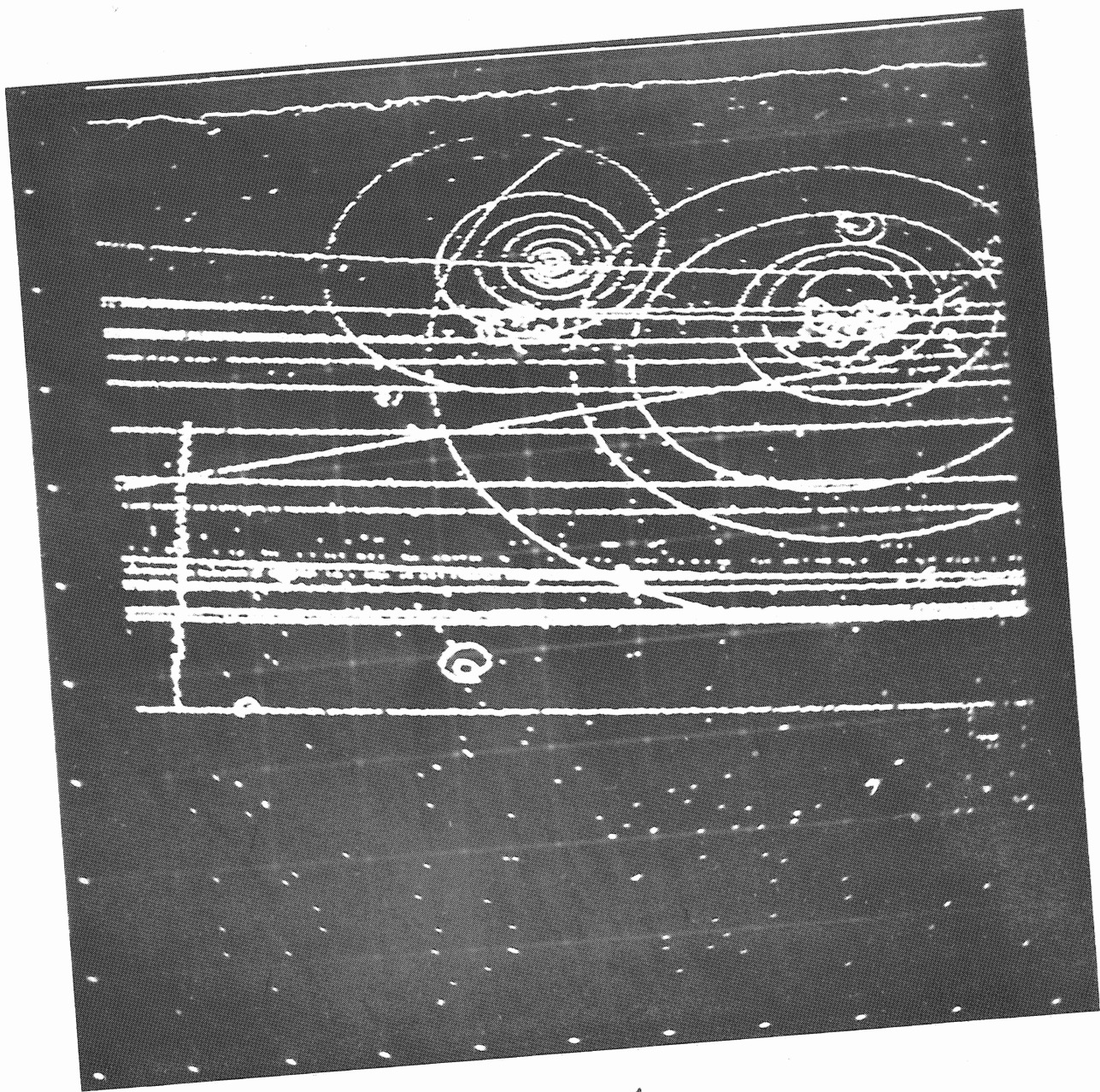

Figure 1

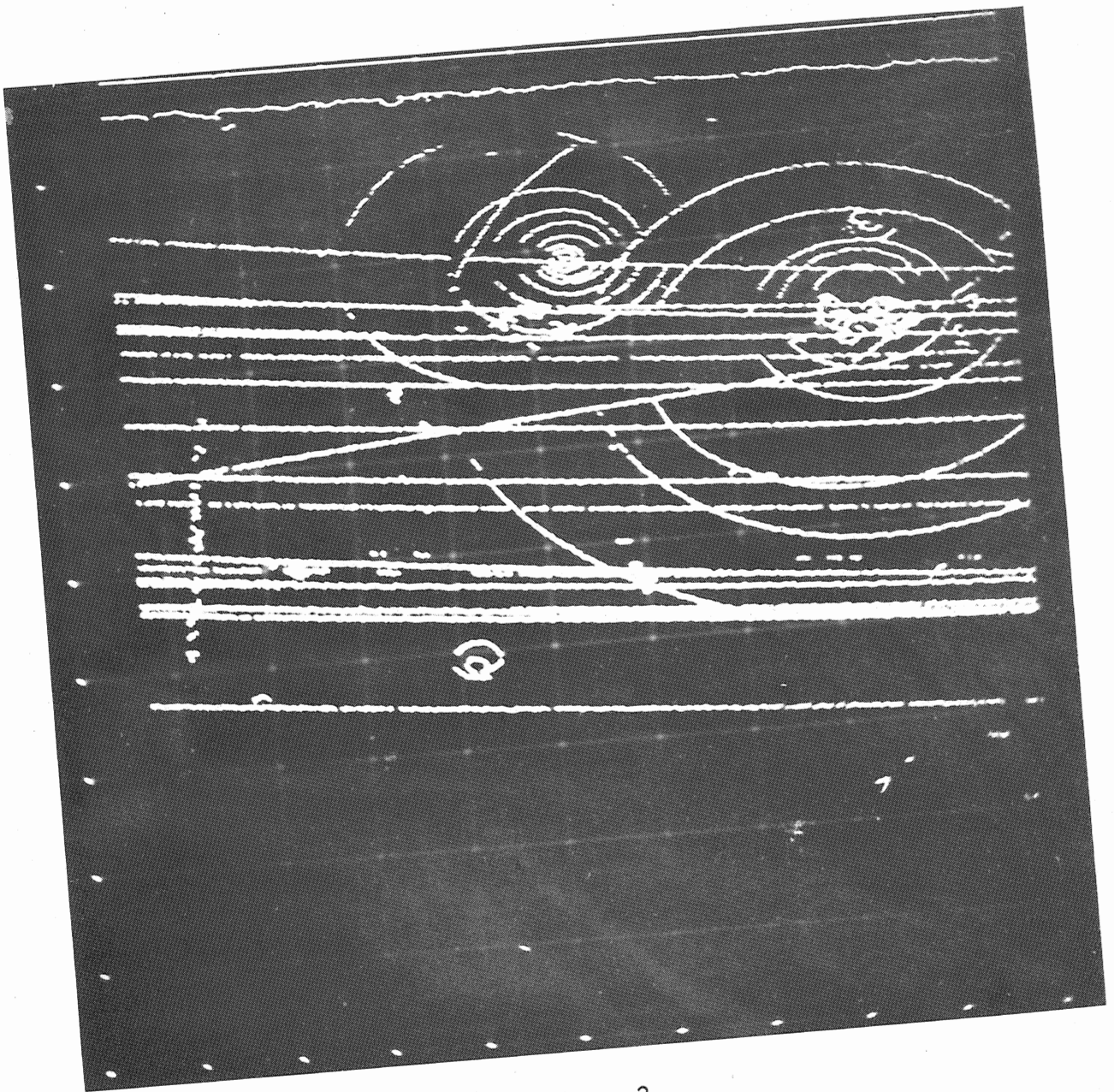

Figure 2

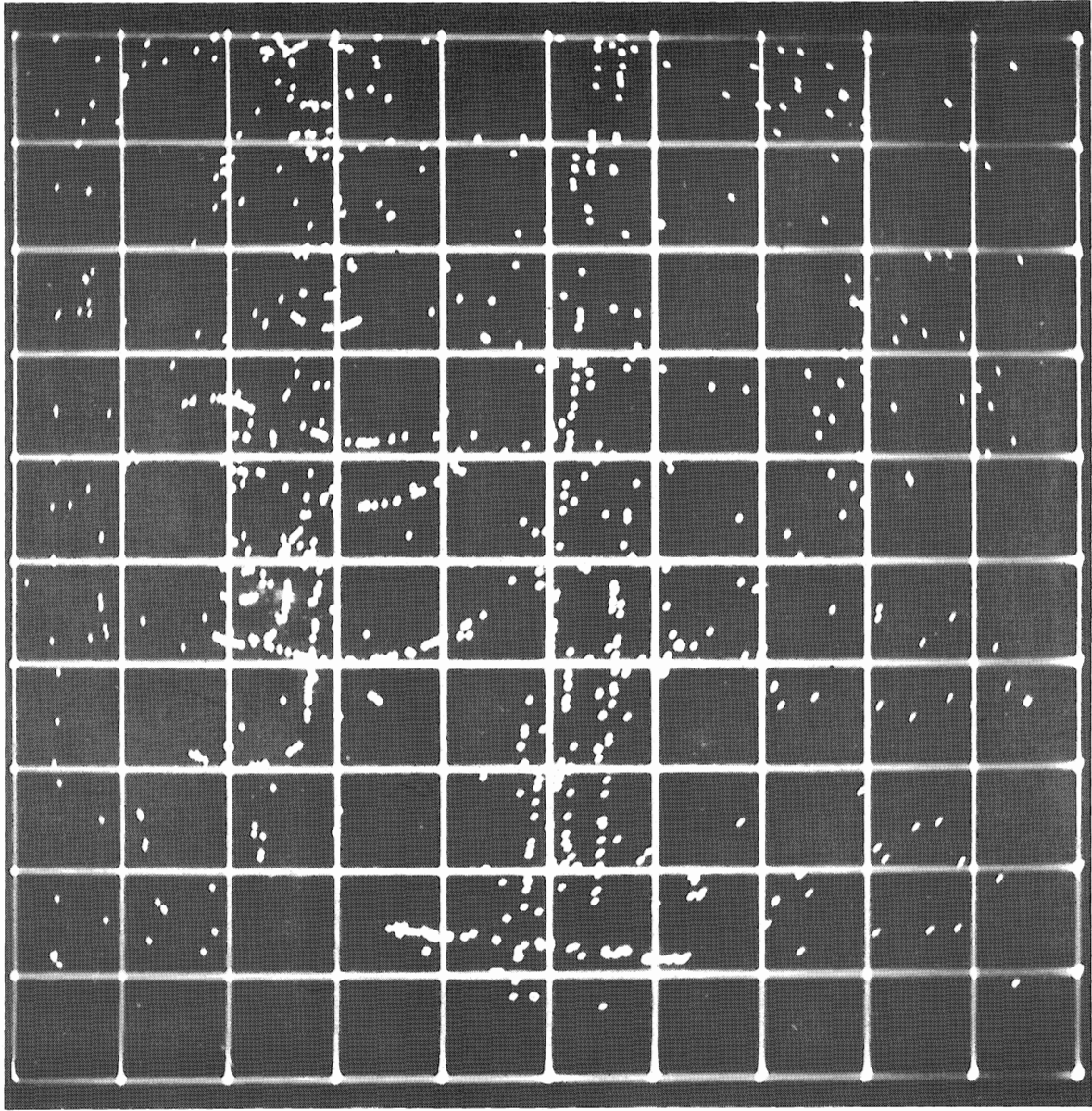

Figure 3

An automatic scanning system for bubble chambers

H.S. White, (Berkeley)

With the operation during 1962 at Berkeley, Brookhaven and CERN of the Flying Spot Digitizer (FSD) as an automatic measurement system, the most serious bottle-neck in bubble chamber data processing operation will be eliminated. The remaining impediments to data processing seem to lie equally in two areas. One of these is the scanning of film to find events of a type suitable for measurement. The other area in which a difficulty of achieving optimum data flow is experienced is that of interpretation of the numerical results. The FAIR and QUEST systems have been formulated at Berkeley to facilitate this data interpretation problem and as they are extended will serve to speed this part of the total data analysis effort so that it becomes commensurate with the rates of automatic measuring and the initial production of film. There remains, therefore, the serious problem of producing scanning rates commensurate with the remaining parts of the entire system. The system being described is designed to remedy this problem.

Total event processing is separated into several phases: the abstraction, event recognition, measurement, and computation. After film has been developed, it is immediately submitted to the abstraction phase. This has as its purpose the recognition of track elements within each view and the abstraction onto magnetic tape of certain basic information describing each track segment so that future access to the scanning-type information content of the picture may be had in a form most efficient for computer usage. The first phase ends with each picture of the film having been area-scanned and information describing each track having been recorded onto magnetic tape. This magnetic tape is therefore a summary in extremely condensed form of the total scanning information available in the film.

A second phase is the scanning (event recognition) process and is done without reference to the film. Track segments described on the magnetic tape abstract are compared to scanning criteria established at the time of execution of this phase, and the result is a magnetic tape identical in format and content to the tape produced by the manual FSD scan tables and that is used to control the measurement process.

The third phase of the total automatic scanning and measuring process is the measurement and numerical analysis by FSD hardware and programs of the events selected during the scanning phase in exactly the same manner that manually-scanned events are analyzed.

If a high-precision measuring device like the FSD is used for abstraction as well as for measuring, it is possible to combine the first and third phases of this analysis by producing during the first (abstraction) phase the compressed scanning information and also a group of precision points describing each track segment. In this case the second (computer scanning) phase produces output resembling Franckenstein measurements and the associated descriptors characterizing the physics information. This output is then processed through the usual FOG and CLOUDY analysis procedures.

There are several reasons that make appropriate the separation of track recognition, scanning, measuring and analysis into at least two parts. If one were to plan complete analysis of all "interesting" events in the film, it is probable that the volume of data to be handled would seriously impede achievement of early analysis of "most interesting" events. Furthermore, the few "most interesting" events are buried in a large sea of data, causing an information-retrieval problem of considerable magnitude.

It seems that manual scanning frequently follows another route from this; namely, that of looking for "most interesting" events to be measured immediately, selecting but reserving "interesting" events for future measurement, and noting still less interesting but more frequently occurring events for possible future scans of limited sections of the total film. This procedure is admittedly a compromise between the conflicting requirements

of a complete scan and a necessity for rapid identification of the most interesting events. However, it avoids the pitfall of having important results delayed by and buried in a sea of less important data.

The automatic scanning system is designed to facilitate this approach without paying the cost of re-examination of the film for each new scanning purpose. The abstraction pass is comparatively slow and expensive, but does not need to be repeated for each new scanning purpose. Rather, the abstraction pass is made in such a way as to optimize the storage of information required by the scanning function so that it is feasible to "scan" for a class of events within data described on an abstract tape and efficiently to select those events for speedy analysis and measurement.

Furthermore, separation of the abstraction and scanning phase allows a cheap rescan with revised scanning criteria. Frequently one finds it desirable to revise scanning criteria on the basis of information acquired using earlier criteria, and therefore the results of manual scanning are frequently divided into separate groups of data which must be independently treated to eliminate known scanning biases. With separated automatic scanning, one merely rescans using the new criteria, and thus has one consistent group. The problem of maintaining consistent scanning standards is, of course, removed by use of a computer in this application.

I believe an earlier stability will be achieved in the abstraction programs than in the scanning programs. It is in the area of scanning that I would anticipate the greatest modification of program abilities. The separation of scanning from abstraction enables a continuous improvement of scanning-program ability without making obsolete the expensive results of the initial area search of the film.

Several independent approaches have been made to the problem of track recognition. One such approach by Irwin Pless at M.I.T. incorporates special hardware built by Digital Equipment Corporation into a device called the Precision Encoder and Pattern Recognition device (PEPR). Another approach initiated by John Pasta of Brookhaven National Laboratory and the University

of Illinois uses a computer program in conjunction with the FSD effectively to simulate the PEPR hardware. Both of these approaches begin with an un-scanned section of film and produce inside the computer memory a list of track elements found within that frame. For economical reasons there may be very significant preferences for one technique as compared with the other. However, hardware of each is presently feasible for the production of such scanning data and either of them could be used in a prototype system. Flexibility must remain to employ the most economically advantageous one when production volume becomes large.

One feature of the FSD approach is that ionization may be measured as well as geometric position, since film images are searched by a dense serial scan using a small round spot as probe. It is possible to detect and measure gaps in tracks as well as to sense individual bubbles. This ionization information is considered a major input to the scanning system. However, it is not necessary that numerical values of ionization parameters be extremely precise. What is wanted is something that simulates the human scanner's ability to separate the tracks into categories by inspection.

The function of the abstraction program is therefore to interrogate the photographic image in such a manner as to detect all track elements contained within the picture. The term "track element" denotes a short segment of track perhaps 1 mm in length on the film that is the basic output of the track search operation. The term "track segment" is used to denote the longest assemblage of the track elements that can be achieved without resorting to stereo kinematics or reconstruction. Thus a track segment normally results from linking many track elements together and this linking process is terminated only by the occurrence of a vertex or kink or else the disappearance of the track. Such a disappearance is attributed to either the physical end of the track or to a long gap or obstruction through which the track may not safely be extrapolated without resorting to the other views. The abstraction phase outputs data associated with track segments and thus performs the linkage of track elements together into segments. The abstraction program is therefore truly the track recognition program.

It is anticipated that for each track in each view three 36-bit words of information are to be written onto the abstraction tape. These words are 12-bit X-Y coordinates for the two ends and the mid-point of a track segment (72-bits) as well as a collection of additional data edited together into the third 36-bit word. This third word includes the classification of the track by ionization (3-bits), linkage at each end (4-bits), sign and determinancy of curvature (2-bits), length (3-bits), initial direction (6-bits), end direction (6-bits), and curvature (6-bits).

If one assumes that each frame contains 25 track segments and that three views of a triad are scanned, 225 words are obtained for each stereo triad. This number seems typical of many pictures in large chambers. Present computer technology allows 10,000 to 20,000 such triads to be recorded on one reel of magnetic tape. Thus one or two good days of Bevatron operation are abstracted onto one reel of magnetic tape that can be completely searched by an IBM 7090 in ten minutes (assuming the search can be performed at twice tape reading speed). The abstraction process is therefore an extremely efficient one from the viewpoint of information accessibility to the computer.

The separation of abstraction from other operations allows a different and much more convenient organization of programs to handle a variety of film formats including several views on one film as well as one view on each film. By separating the frame-by-frame track-recognition and abstraction phase from the triad-by-triad scanning phase, it is possible to abstract independently the several views of one triad and thus hardware may be used which accepts only one piece of film at a time. There is no loss of efficiency in having only one unit of hardware available to transport film and in using this hardware to read separately in time the pieces of film containing the stereo views.

Much advanced thinking and program development of this phase of activity has been done at Brookhaven National Laboratory, and it is our intention to capitalize upon developments being made there. Present development

has demonstrated the feasibility of the track recognition phase with existing techniques.

The scanning phase program assumes as its input one tape containing the results of the track search and abstraction having all views merged together. This program searches for vertices of a given nature, tracks of given length, orientation, momentum or ionization, and may require that the vertex be linked in some pre-specified manner to other vertices in the picture. Positional criteria may also be imposed to limit events to those contained within a fiducial volume. In general, these are the parameters that are observed by the human scanner to provide the basis of his scanning decision.

Further thought processes occurring within the human scanner's mind may be grouped into two categories. One of these consists of applying pre-defined event types to the data at hand to test the hypothesis that these data fit a given event type. The second category of scanner thought includes reasoning about those events which fail to fit previously-defined criteria or which "seem worth considering further". This division-making process in the scanner's mind is subjective; in the computer it is objective. One might operate in such a manner that all expected occurrences in the film are described to the program, and then ask that all vertices be identified with one or more such descriptions or else reported as exceptions. In this way frequently-occurring exceptions may be added to the repertoire of configurations known to the scanning program so that exceptions would become less frequent. The process is then restarted with the new criteria. Thus it is possible efficiently to combine a person exercising reasoning ability with the computer program exercising objective classification ability in such a way that constant improvement of the system is achieved.

This separation of scanning from abstraction allows multiple passes through the scanning program. Since approximately 2,000 pictures can be

"scanned" per minute with an IBM 7090, scanning of entire runs of 200,000 pictures can be done in perhaps three hours. The scanning process is efficient even when used to search for a small subset of the total data. Some scanning-type experiments may be performed on this tape without further measurement. Calibration of scanning procedures can reasonably be made over the entire experiment. Events of one particular type may be selected in one pass or events of several tapes may be equally-well selected. Thus the scanning procedure is flexible to meet the needs of scanning and priority of interest. It is possible to sample portions of the data just as manual scanning is done in a selective way over part of the film.

When scanning and precision measuring phases are separated, the output of the scanning operation is a tape that has the same physical format and some logical content as the output tape from the present FSD scanning table. Sufficient information for road coordinates is contained in the abstracted data. The scanning program has the ability to identify tracks, to assign events to given lists of data, to specify masses and, in general, to perform all of the functions presently performed by human scanners with the FSD scan table. This output tape contains sufficient information to allow completely automatic measurement by the FSD system as it is presently being developed. The tape produced in the scanning process may be merged with tapes produced by a manual process so that occasional manual intervention will gradually replace completely manual operation.

When scanning and precision measuring phases are combined, the abstraction tape is produced in the same format as before but also an additional tape is produced containing perhaps 10 precision points for each track segment in each view. The scanning phase program then edits the contents of this precision tape into a format suitable for input to the FOG-CLOUDY analysis program.

In the future, additional media other than bubble chambers will be used as particle detectors. It is likely that these other devices will have resolution comparable to that of bubble chambers and that the kind of information used will approach that presently used in bubble chambers. Early experiments with these devices will probably record data on photographic film as is conventional in bubble chambers. However, because of very different data rates and slight differences in resolution, it may be feasible to have immediate transmission of data from the device to the computer. Development of a scanning procedure along the lines of this proposal will pave the way for this possibility in two ways. Experience will have been gotten with the techniques of specifying criteria. Large data rates will have been handled, so as to give experience with the problems occurring in extremely large scale data analysis.

This program could be adapted to the requirements of a direct transfer system by producing two tapes during the real-time (simultaneous with accelerator operation) abstraction phase in the same manner as described for the operation from film with a high precision scanning device. This would provide a linkage during the transition from experiments to be recorded on film to those not to be recorded on film.

DISCUSSION

(Communications 7 and 8)

ROSENFELD: I do not think that Hough quite does justice to the point that he is making, without mentioning that he replaces our investment of \$40 - 50,000.00 in maintenance and in digitised scan tables for each scanner.

At first this business of recognising track segments on everything seemed a little shocking, but if one is shocked by the idea of devoting lots of 7090 time or 6600 time to doing this on everything that is exposed, at least one should recognise that once roads are made on data one is really interested in, then if one can put that on tape, one very quickly generates a magnificently-useful track-segment or road library which one can then go back and use for other experiments without having to go all the way back to the beginning of the tedious system.

McCORMICK: One comment I would like to make is on the use of magnetic tape as a storage device. It seems that a very minor investment in a film-reading device would be probably much more effective storage. After all, the bubble chamber film is already ideally stored, it is not going to be changed, it does not get rubbed out in the light, and with a minor scanner attached to that you have a film-tape transport which seems much more appropriate to this area.

WHITE: This is certainly true, I see the Hough-Powell device as a film-tape transport, but there is the problem of converting the information content as it comes out of the film through that tape-transport into data the computer can easily deal with, and the magnetic tape is really a reservoir in which the results of this process are stored and one does not have to re-do it each time a new scanning pass is made.

Results obtained with the Spiral Reader

L.W. Alvarez, (Berkeley)

SUMMARY

The Spiral Reader was originally conceived by B. McCormick, and was developed under his direction until he left for the University of Illinois. At that time, the responsibility was transferred to J.A.G. Russell, with the mechanical design divided between J. Franck and F. Plunder, and the electronic design divided between T. Taussig and J. Salvador. The filter programme was originally written by D. Innes who has been joined by W. Graziano. Since J. Russell left for Brookhaven, J. Salvador has been in charge of the programme, and has brought the machine to its present state.

(Prof. Alvarez showed some slides of the Spiral Reader giving general details and results of scanning different track configurations).

The first figure shows the scanning table designed by J. Franck. On figure 2 one can see the back end of the machine, showing the housing that holds the rotating device that makes the spiral scan. Figure 3 is looking into the spiral device which now has a periscope which moves up and down and rotates around (designed by F. Plunder). In the upper part of figures 4 and 5 the data that goes onto magnetic tape is shown i.e. this is what the Spiral Reader sees. The magnetic tape is then fed into a 709, later of course the 7090, where the filtering operation takes place and in the lower part of the figures one sees the results after filtering.

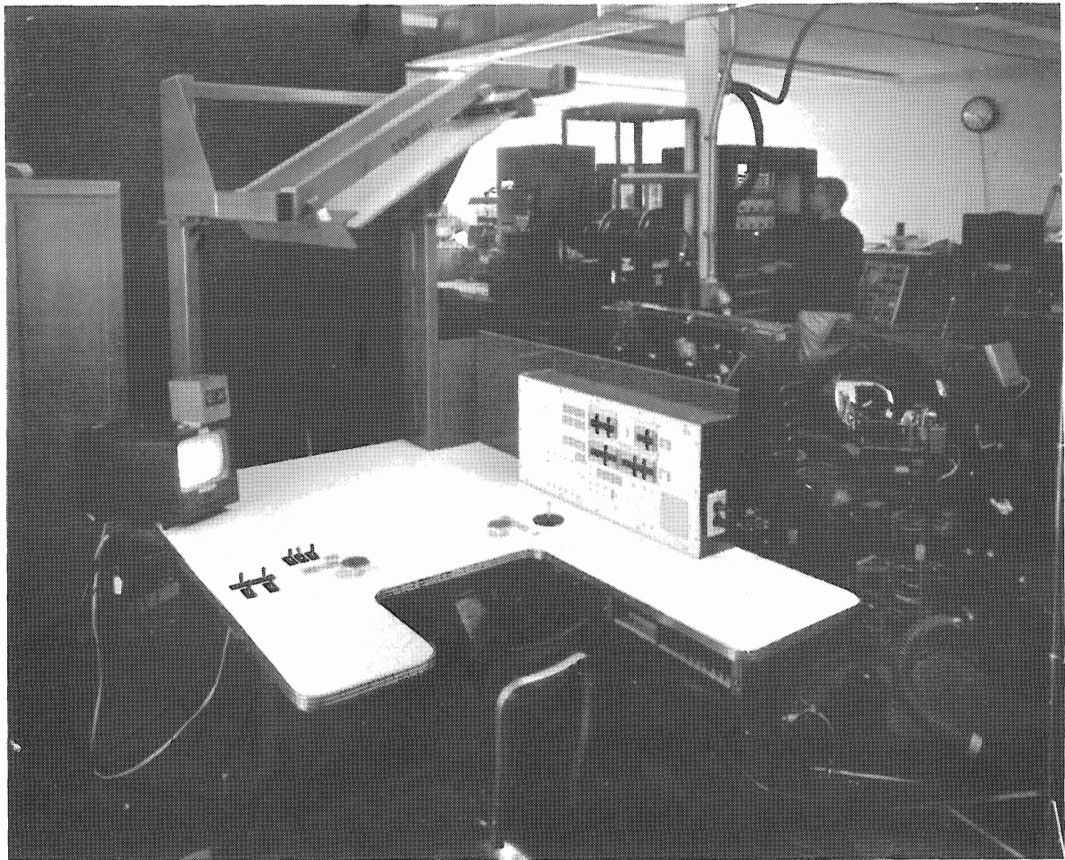

Figure 1

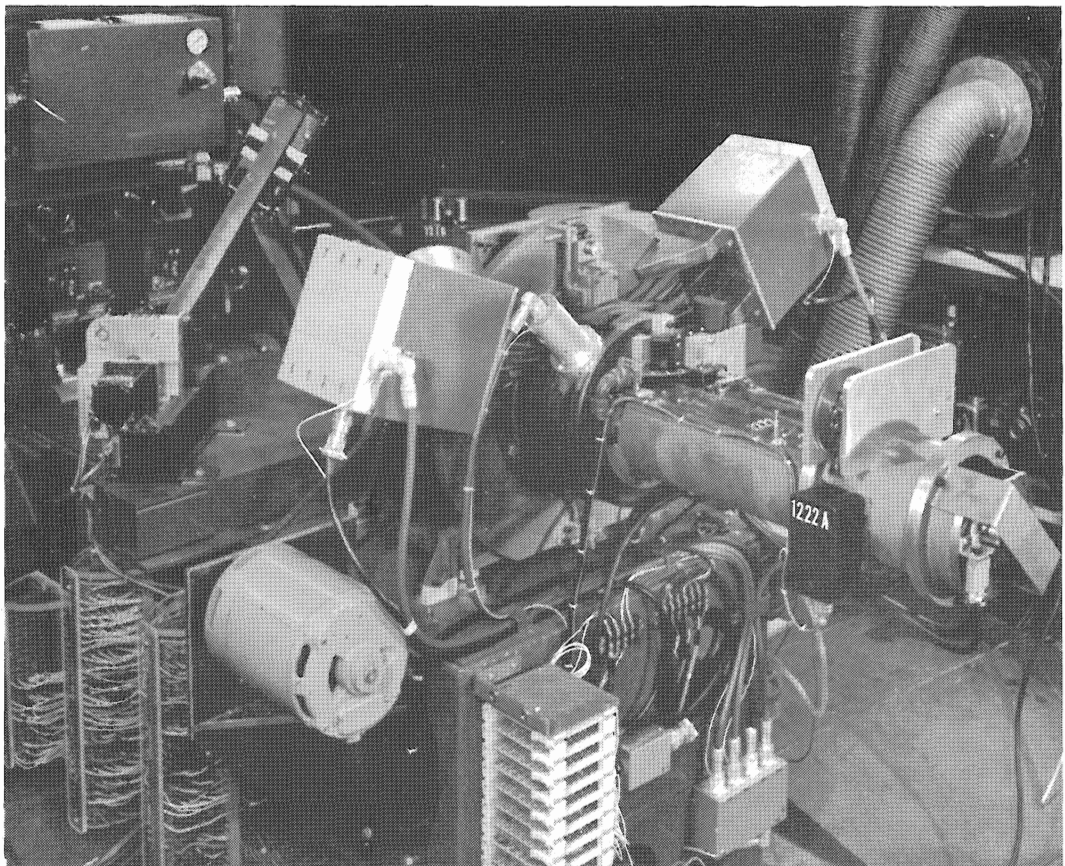

Figure 2

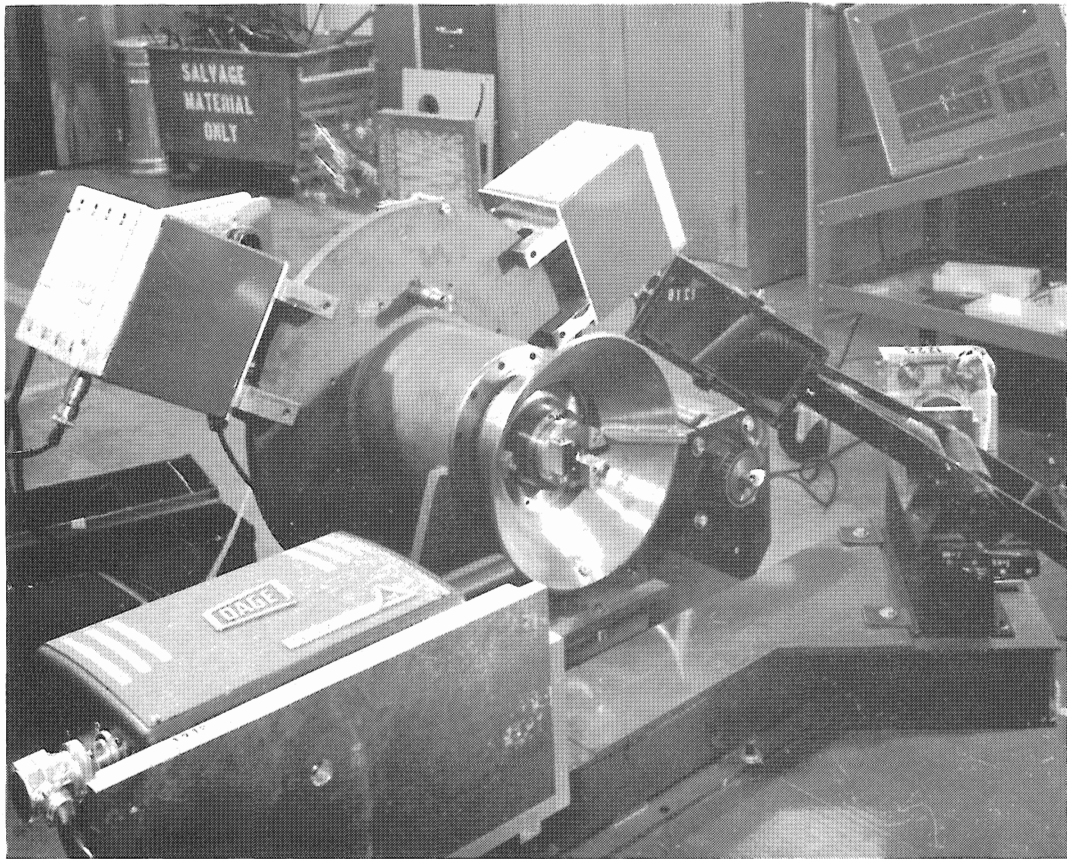
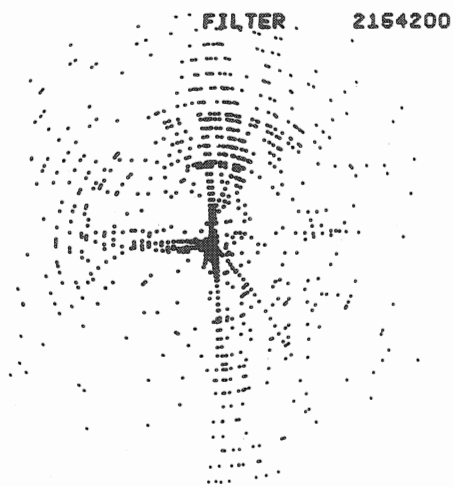

Figure 3



FILTER 2164200

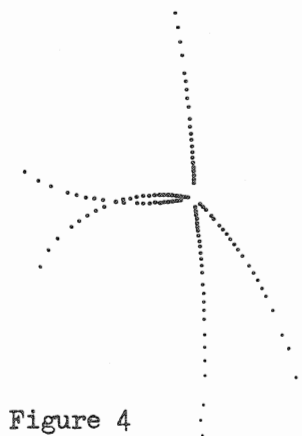
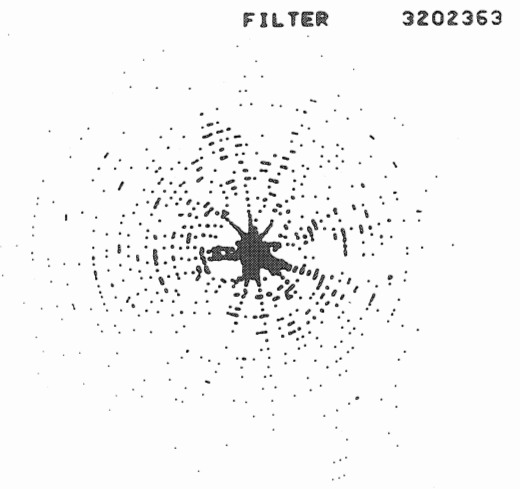

Figure 4



FILTER 3202363

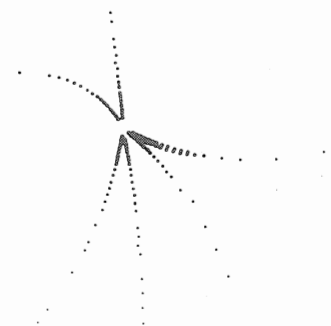

Figure 5

On-line aspects of SMP

J.N. Snyder
(University of Illinois)

Note by the editors: this paper is a condensed transcript from magnetic tape, which has not been revised by the speaker.

In Prof. Hulsizer's presentation at the Instrumentation Conference he barely had time, in describing the SMP system, to do more than describe the device itself. The complete system, however, encompasses not only the device, but also the on-line aspects of a computer. In the following, references will be made to the 7090, since this computer is the most familiar one, but this choice is in no way crucial: any computer with a fast data channel and interruption facilities would suffice. Let us consider briefly the interruption facilities and the method in which several SMP's may be connected to a 7090. About ten SMP's will saturate a 7090, an estimate which is probably quite conservative. These are connected through a multiplexer to the direct data channel. The multiplexer is simply a rotary switch, which goes around fast enough to sample each SMP output within that interval of time for which a given co-ordinate measurement will remain in the output register of an SMP. If ever a 7090 has to handle so many SMP's that this could not be achieved, then buffering would become necessary.

In addition to this each SMP is provided with a typewriter. It is rather unconventional to use the 10 available sense lines in, and the 10 available sense lines out to operate these typewriters. Most on-line applications of 7090's tend to use the Direct Data buses for this kind of operation. There have to be again two multiplexing boxes, one which contains an input, and one which distributes the output, from each typewriter. Four of the ten sense lines can be used to select any of 16 typewriters. The other 6 then

suffice to transmit a conventional IBM character which is encoded in 6 bits.

Let us see now the set of programmes that will be used to operate the system. These can be divided into several parts, of which we shall mainly discuss the executive routine, but three other categories of routines are also present. One is a filter programme: this type of programme and the techniques used have become quite familiar. They are used in all second generation machines and, I believe, hark back to the really ancient air-traffic control problem which started in 1952. There is a group which we shall for the moment call "short routines", and see later what type of routine would be entered into that category; and then there is the traditional kinematic and spatial reconstruction routines - PANG and KICK or as it is now called PACKAGE. At Berkeley this runs to about 28,000 words which is probably too long. It could probably be pruned a little; especially it could have its event type sub-programmes removed and stored temporarily on tape, which would probably free enough of the memory to allow all four of these routines to be in a 32,000 word memory at the same time. Even if this is not true, there would be very little degradation of the system by storing the appropriate parts of PACKAGE on a magnetic tape. These need be called forth only once per event that is processed, and hence, the time delay in calling them forth would not be serious. Events will be processed on each SMP in a period of about one to five minutes (depending on which generation SMP you are talking about) and will continue to improve.

We return now to the executive routine which also contains all of the time sharing and interruption facilities which such a system must have. The routine actually consists of several loops. The first loop we will label "examine each SMP in turn, round-robin fashion, asking if filtering of the data from that SMP is necessary". It is implicit here that all SMP's feed their data down a common line into a common "circular buffer". This term means a list of words which is in the memory and which is successively filled by these co-ordinate observations. Each observation when it appears

on one of these lines will automatically be given a label indicating which table it originated from.

This buffer will gradually fill up with interleaved measurements from the mixed SMP's and when the data has filled the buffer it automatically starts overwriting the starting point in this circular buffer. How the buffer is emptied is, of course, the duty of the processing routines. But the main executive programme which is a big loop with three minor loops therein looks as follows: first loop is simply to examine each SMP in turn in sequence and ask: is there a complete track from that SMP in the buffer? If not, go on to the next SMP. If so, filter that information out of the buffer thereby freeing a portion of the buffer, clean that information up, put it in a separate bank where complete tracks (sorted by SMP table) are recorded.

Circulating around this loop has highest priority, of course, because as is probably obvious we must empty the buffer as quickly as possible. While you are not doing that you go around another loop which asks if there are any short processes that need to be carried out. Circulation around here means: examine each SMP once in round-robin process for either any short processes that need to be carried out for that SMP; if none, try the next SMP and so on. Now what do we mean by "a short process"? Each SMP will have a separate buffer - a separate area of storage in which tracks for that SMP are being built up as an event is being processed. Before one goes into the complete kinematic analysis of the complete event, but on a track level as each track comes in, there are certain things that have to be done for each track. In particular, it must be optically corrected both for the camera lens of the chamber and for the second lens through which the SMP projects. This has to be done once for each track so you get around to it quite frequently. Finally, at lowest priority, you can run around a loop, asking once for each SMP in sequence, if the tracks necessary to process a complete event have yet been accumulated from that SMP. If the answer is yes, then proceed to do the conventional things which we all know about-PANG, KICK and so forth, and then back to the beginning.

This sequence is smooth enough, but it is complicated by all of the interrupt procedures. There is no interruption necessary to handle the direct data connection. The buffer is circular, and if the 7090 can be given the order at 8 in the morning to connect and put into action the direct data connection, that suffices for the entire day. The only interruptions will be those connected with communications, operator to computer and computer to operator. For example, a key stroke on a typewriter. The end of an answer which the operator has provided the computer in response to some question, is very naturally indicated by a period, and so forth. Or the end of the question that the computer is giving the operator, can probably be recognised by a question mark and special characters appearing on those six lines we spoke about. Any key stroke on the typewriter will cause an interruption and you will go into a routine which now must take action. It examines what character has appeared on the six lines. This can be one of many kinds. For example, this could be simply the return of some character of a message, a letter for example that the operator is typing in "yes", or something, as the response to a question. This very complicated testing sequence will recognise that this is the intermediate stage in the acquisition of some response from the operator, and if that be the case simply store it and go on further. If on the other hand the computer is typing a message to the operator, the typewriter takes a few milliseconds to type the characters.

Results from the SMP

R. Hulsizer, (Berkeley)

(Note by the editors: a paper on this subject was submitted to the Instrumentation Conference, held at CERN on July 16 - 18 and is included in the Proceedings of that Conference, to be published shortly in "Nuclear Instruments and Methods". The Informal Meeting of July 19 offered the author the opportunity for a more detailed presentation and discussion).

DISCUSSION

(Communications 9, 10 and 11)

ROSENFELD: Snyder talked about the time-sharing problems. It looks hard for a place like Berkeley where we have plenty of PAKAGE to do just to run yesterday's PAKAGE from the FSD with the same SMP to fill in the spare time.

SNYDER: That would be fine if you could shorten PAKAGE a little so that the SMP executive programme can be in there at the same time.

ALVAREZ: The Berkeley HPD has a memory of its own, so that we do not have to take Snyder's way out.

WHITE: 128 18-bit words is all the memory we have.

PARKER: How about drums, can they be emptied rapidly enough to make typewriter times?

SNYDER: Unfortunately the 7090 does not have a drum, but the new Illinois computer, for example, will have a drum with 7 usec transfer time. This would be a very fine computer for it. The best you can do on a 7090 is 90 kc/s character rate.

TYCKO: Are discs commercially available for 7090 and how do they compare with the tapes?

SNYDER: 90 kc/s character rate-exactly the same. The only advantage being their better access. It is not serial, you do not have to wait two minutes to rewind the tape.

HULSIZER: I do not thin the typewriter handling is a problem, the thing is that the programmes to handle the typewriter characters can be brief enough so that they do not use up an appreciable fraction of the memory and can be left in as part of an executive system. It is the filtering and particularly PAKAGE that is going to rob another user of his memory space.

POWELL: I would like to ask three small questions. Firstly, do you have any comments to make on closely-spaced roughly-parallel tracks as to how you might measure them? Secondly, how do you expect to handle fiducial marks and short tracks such as the Σ 's for instance? And lastly, do you see any difficulty with tracks which are obtained with a rather cold chamber, that is to say when there are many gaps and perhaps when the bubble diameter is rather smaller than you usually have in the 72 inch chamber?

ALVAREZ: The last question first. All of the testing of the SMP to date has been made on the worst film that we could find. About the fiducials, we have two plans - one that will be in on the first model and that is we will bring the three fiducials into the centre of the chamber so you can just measure them like that; we are using the ones which you and your friends prevailed upon us to put on a 72 inch film.

HULSIZER: We have not yet followed any closely parallel tracks. We have had our filtering running for about a month. We have been able to distinguish small kinks in the tracks, 5° scatter and hang around the kink, and we have followed tracks through intersections where other tracks have come right through at small angles, but we have not actually taken any beam tracks that ran parallel for the whole length of the chamber and tried to hang on to both of them, which would be the acid test.

ALVAREZ: In later models we will build something that is automatic measurement of all the fiducials. You just put a little cross of fibres, take the fibres to 2 photo-diodes and these things sit at the four corners of the projection screen where the fiducials are going to be approximately. Then you take the whole thing, put a wedge over the lens - you just rotate the thing around so that the whole picture stays parallel to itself and the track will cross twice to give you a nice solid signal. You find the position of the fiducials from the difference in phase of the two signals.

POWELL: What do you think the shortest track length you can measure would be?

ALVAREZ: I think we would do as we do at present - let the computer calculate it by tracking back.

HULSIZER: The filter routine is experimental - it is in FORTRAN so we can understand it, but it would go in machine language when we have it working well.

SNYDER: One comment having to do with the parallel track problem, and one about the short track problem. The filter routine will discover it is in trouble if in the buffer it extracts all of those points from one SMP and suddenly finds two tracks. Being on line it can then branch to a special error script which calls upon the operator "please mark the track that you are interested in", which the operator can do with a cross-hair. Then it has a firm point to start with. The computer can do the same thing for the short track.

ALVAREZ: The same general technique has been used in the filter programme for the Spiral Reader. We now have a programme called CRUTCH which allows the operator to mark a point on tracks. It is even nicer on the SMP because you only use the CRUTCH when it turns out that the filter is having trouble. With the Spiral Reader you do not know that it is having trouble until you feed the tapes in the next day, but the SMP can ask you for this help at that particular moment.

II. AFTERNOON SESSION

Chairman: Y. Goldschmidt-Clermont

Multiple slit rotating analyser

G. Brautti, (Trieste)

The MSRA is a device of intermediate speed and precision, which may allow to small laboratories a reasonably fast analysis of some type of bubble chamber events without the need of a large on-line computer. The mechanical part of it is shown in figure 1.

The vertex of the event may be centered on the center of a continuously rotating disc. This holds a slit, under which are located 12 equally spaced photocells. Each time the shadow of a track falls on the cell, one obtains a pulse. The position at which a pulse appears is digitized by counting with a photodiode the pulses from a graduation drawn on a suitable transparent disc connected to the rotating part. The sensitivity of the digitizer is now $6480 \text{ div}/2\pi \text{ rad}$, which will soon be increased to $19440 \text{ div}/2\pi \text{ rad}$.

Pulses from the photocells are shown in figure 2: 2a shows the output of the outer cell, and 2b the output of a cell near the center of the event, where one oscilloscope sweep corresponds to a complete revolution; 2c shows a pulse corresponding to a single track.

A straight radial index (not shown in figure 1) may be superimposed on the rotating disc and orientated by hand. This gives coincident pulses from the photocells, and may be used as a reference direction or to measure the line of flight of a neutral particle.

The first method of using the pulses is shown in figure 3. The center of the pulses has been found simply by differentiation, taking the reset pulse of the discriminator as the center time. The pulse from the adder corresponds to the index position, and with the circuit shown the polar coordinates of the twelve points on the first track crossed by the slit after the index position are measured.

A faster type of analysis will be probably used in the future, with the circuit shown in figure 4. After amplification and discrimination the pulses will be memorised in twelve shift-registers, using the pulses from the graduation as shift-pulses.

Now a curved track coming out of the center of the disc gives approximately equally-spaced pulses in the photocells, so that a track of well determined curvature may be detected by a delayed coincidence system.

This is obtained by summing the pulses in the sense wires through the shift registers cores, as schematically shown in the figures. A "high" pulse in a sense wire determines so both the angle and curvature of the track.

Some tests were made to check the precision obtainable by plotting the measured angle versus the cell distance from the center for single tracks. Those preliminary tests gave a r.m.s. deviation of 8 microns on the film, most of which seem to be due to the lack of noise filters in the amplifiers, and to the reduced sensitivity of the digitizer.

The main expected features of the device are summarized in Table I.

MULTIPLE SLIT ROTATING ANALYSER

	First mode of operation	Second mode of operation
Cost	3000 dollars	5000 dollars
Speed (for 6-prong stars)	5 events/hour	30 events/hour
Output	Punched tape	
Information output	12 points on each track and each view	projected angle and curvature of each track
Digitizer sensitivity	1/3078 radians	1/3078 radians
Precision of track centering	Better than 5 microns r.m.s. on the film	
Operations required	Vertex centering track choice	Vertex centering

Table 1

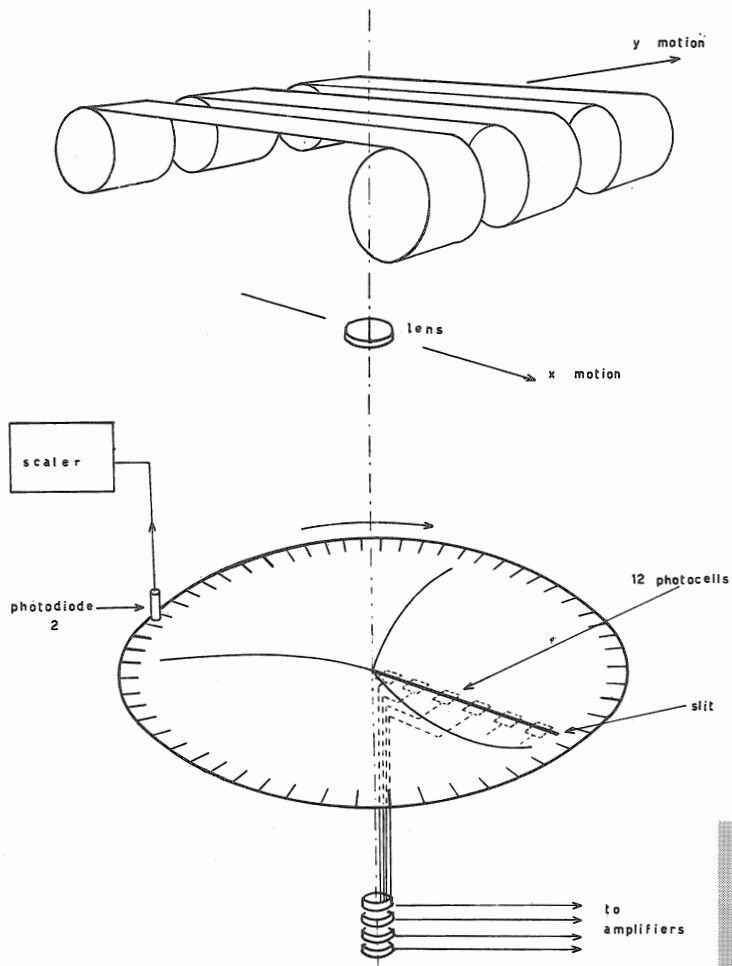

Figure 1a

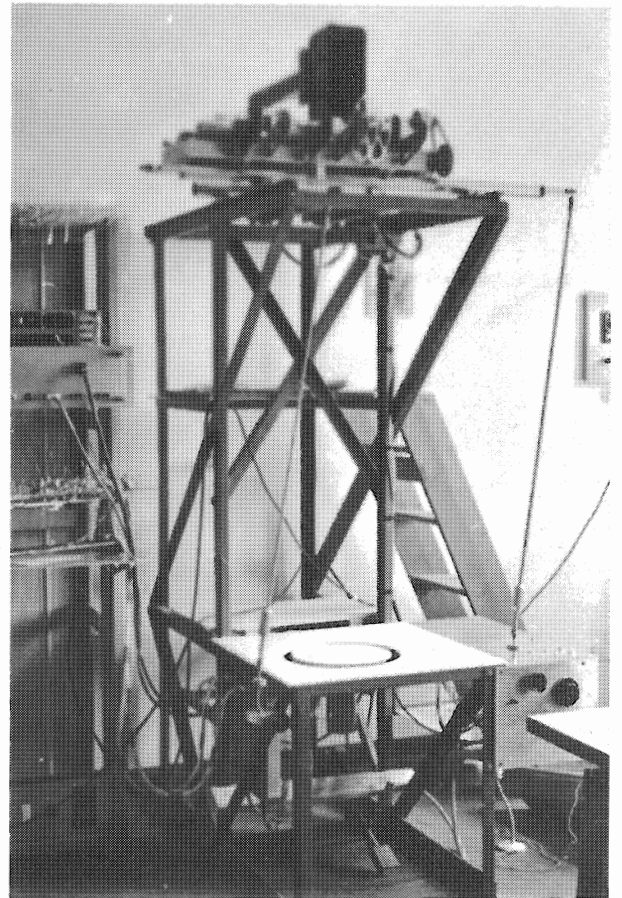

Figure 1b

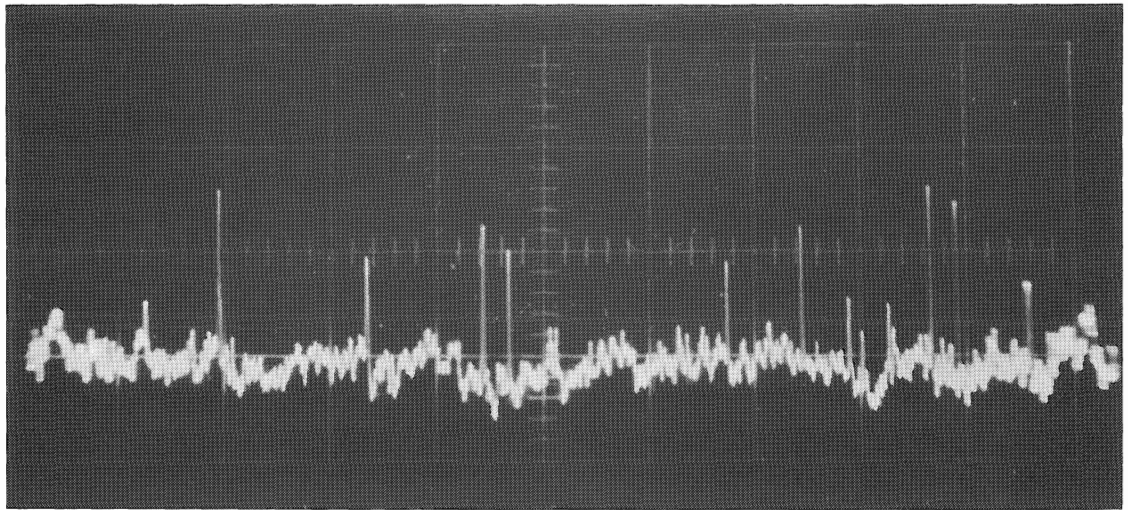

Figure 2a

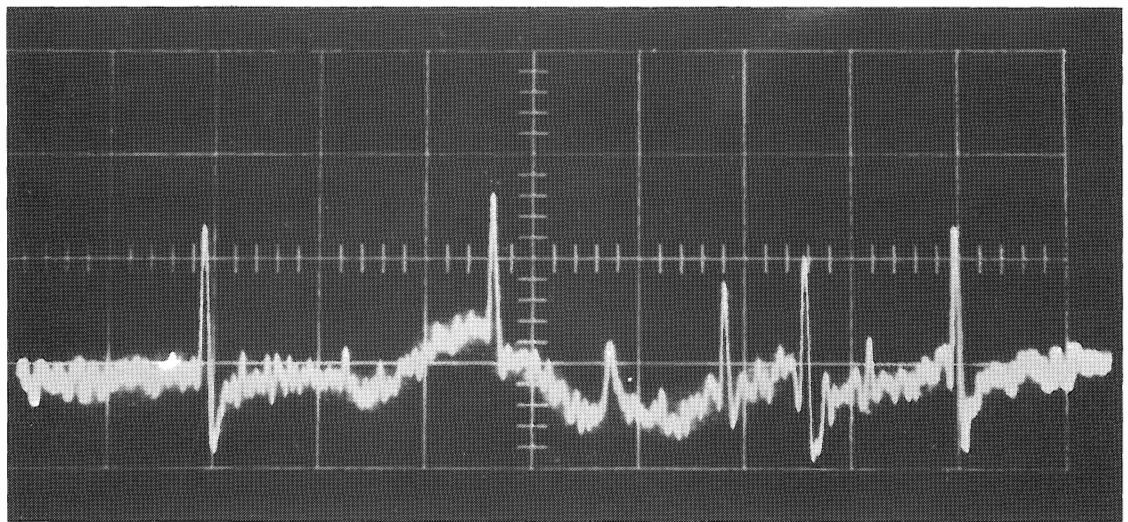

Figure 2b

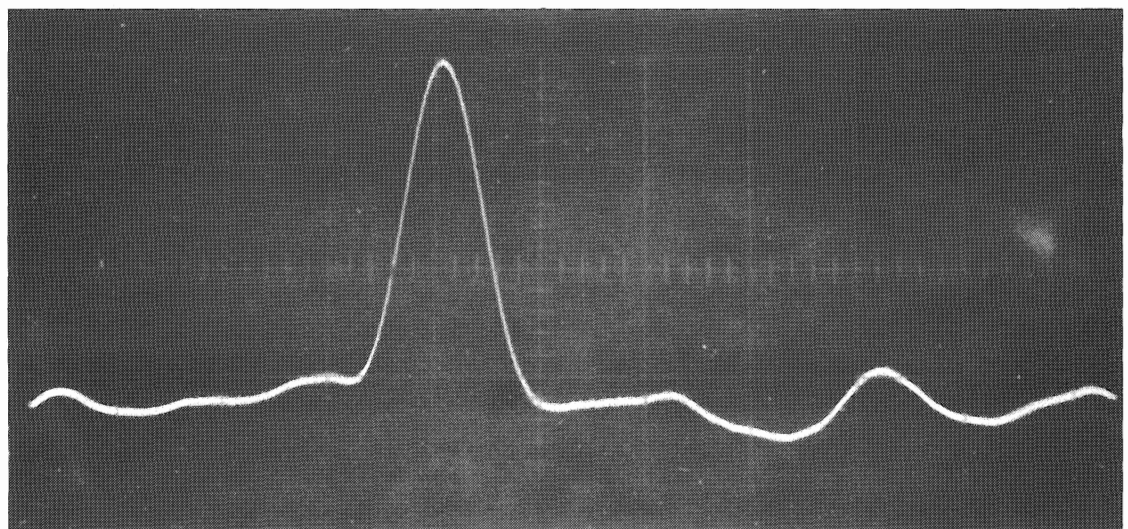
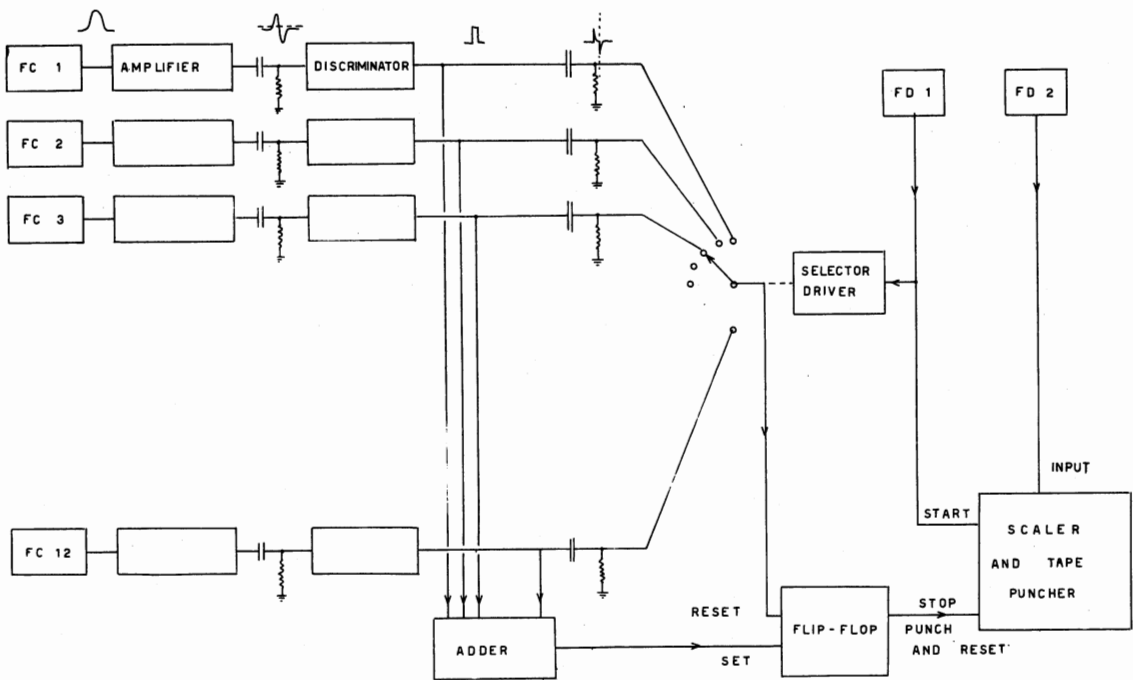
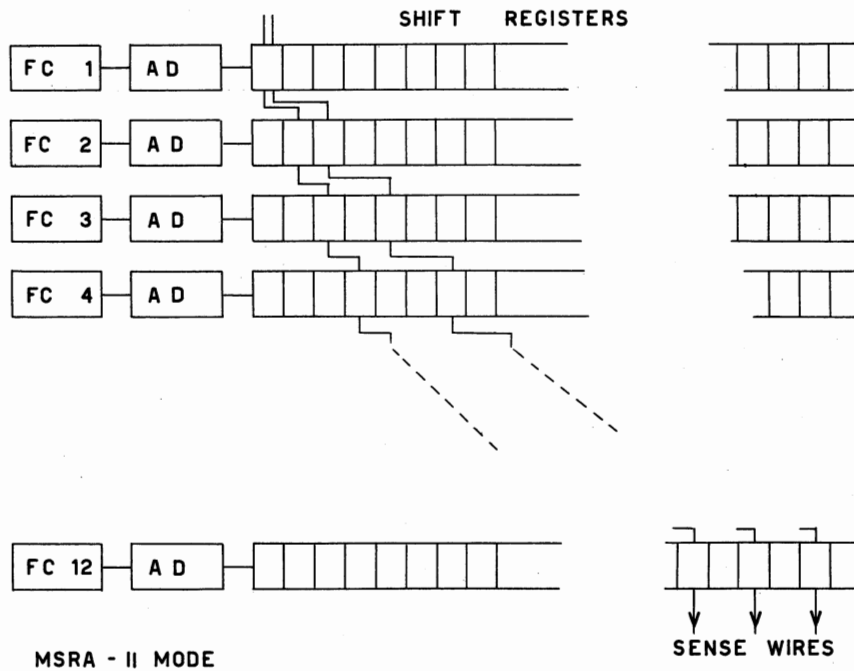

Figure 2c



MSRA - I MODE
BLOCK DIAGRAM

Figure 3



MSRA - II MODE

Figure 4

RHODA: A proposed Rapid Hand-Operated Digitizing Apparatus
for the measurement of track chamber photographs

O.R. Frisch, (Cambridge)

1. Introduction

This apparatus has been inspired by the "shaky table" of Luis Alvarez and has these points in common with it: it uses a projector to throw a picture of the film down onto a horizontal table, a lattice of accurate "bench marks" to measure against, and it does not ask the operator to make accurate settings. It is simple and cheap and needs no computer on line; it should be accurate as the bench marks and quite fast though it requires a little more skill and thought in use.

2. General description (Figure 1)

The part handled by the operator is a flat round box, white on top, about 10 cm in diameter. It is slid along the projection table until the track wanted falls on it, and then adjusted until the track lies between the two red lines R and is about parallel to them, with the point whose coordinates are wanted on the centre line. That setting can be done quite fast as it need not be accurate. The operator then presses a pedal; this causes the sliding piece S to travel about 1 cm (as shown by the arrow) in about half a second and then quickly back again. A photocell under the scanning slit A records the dip in brightness as A crosses the track image; the distance the slit A has to travel to the middle of the track is digitized (see later).

In addition we need the accurate location of the box, and the angle α between the x-axis and the direction in which the sliding piece moved. A simple coded disc can give us α to $\pm 0.7^\circ$ (8 bits) which is good enough. The approximate position of the box is obtained by two further coded discs which measure the angles between the arms of a simple elbow linkage by which the box is connected to the table. Such a system has been built by Adair and is known to give quite good accuracy, certainly the $\pm \frac{1}{2}$ mm which we need here.

The accurate position of the box is obtained by reference to a lattice of precisely positioned bench marks. A raster of clear "polka dots" (about 0.1 mm in diameter, with a lattice constant of about 0.5 mm) on a coloured, say yellow, background is clamped against the track film and projected together with it. The photocell behind the slit A is protected by a yellow filter so that the dots don't affect it; but there are two more slits B and C on the movable slide, and the photocells behind them are protected by a blue filter so that they receive no light unless the slit B (or C) moves over a dot. B and C are of such length and are staggered so that neither can pass two dots at once (which might cause ambiguous signals), yet one or the other is bound to cross a dot within the 1 cm travel of the sliding piece S which carries all the slits. The signal from the photocell behind B (or C) is used to digitize the distance S has to travel to the nearest dot; if both B and C produce signals the better signal is selected (see below).

3. Details

Let us assume 10-fold magnification for the projector, which should be enough for the crude settings required. The projected dots are then 1 mm in diameter, 5 mm apart. The tracks will look about 0.2 mm wide. Slit A should have about that same width, 0.2 mm. Its length might be 5 mm; with that length a misalignment by 2° (easily avoided) or a radius of curvature of 15 mm (on the table) will not worsen the signal much.

The signal - light intensity through A, as a function of the distance A has travelled - will look somewhat like figure 2, and we require the distance a to the centre of the track, accurate to 0.02 mm (i.e., 2μ on the film). It is easy to set to $\pm \frac{1}{2}$ mm, hence 6 bits of information are enough. To get that information I propose to square the signal (see fig. 2) and use it to gate a clock signal (c), generated by a magnetic pickup, from a tape attached to the sliding piece S. The clock signal will be transmitted at full frequency until the gate opens, then at half frequency until the gate closes again, and then no more; in that way the total number of pulses

transmitted is a measure of the distance to the middle of the track. That number is converted into digital form (binary or decimal) by electronics outside the box and finally punched on tape.

Slits B and C are 3.5 mm long and staggered with an overlap (Fig. 3) of 1 mm; hence neither can touch two dots at once, but one of them must traverse a whole dot before long, giving a standard signal (3a). Sub-standard signals (when only the end of a slit passes over a dot, or when a dot is partly obscured by a track or a smudge) will be rejected by the electronics; if both slits produce standard signals the one from slit C will be rejected. If both signals are substandard the operator will receive an acoustic signal, telling him to try another point along the track; this should not happen often. The signals will be squared and digitized in much the same way as those from slit A. The gate that halves the rate of the clock signals must not operate before the photocell has been in darkness (the slit may have been on a dot when it started to move, and that dot must of course be disregarded), and both trains of pulses must be counted and the numbers stored, before one of them is rejected (or both) as being substandard. Probably a signal can be accepted if it has the correct number of half-rate pulses, corresponding to the full width of the dot, though one might think up other tests.

The longest travel needed will be about 3 mm (see Fig. 3), so about 9 bits of information are required; one further bit must be punched to tell the computer whether the signal came from slit B or C.

So each time the pedal is pressed the following data will be punched on the tape; the "elbow angles", indicating the approximate coordinates X and Y of the centre of the box, accurate to about $\pm \frac{1}{2}$ mm (say 10 bits each if an area of not quite a square metre is to be covered on the table); the angle α ; the distance a by which S had to travel before the slit A passed the centre of the track; the distance b (or c) by which S had to travel before the slit B (or C) passed the centre of the nearest dot;

and one more digit which is 1 if b and 0 if c is punched. That makes 44 bits in all; on 5-hole tape, with each number recorded as a separate row of holes, each row with a parity check, we need 13 rows.

That, and the need for a special computation to obtain the accurate coordinates, is the price we pay for getting accurate figures by a stepwise, roundabout procedure from fairly crude and hence cheap equipment. However, both the reading of the extra rows (ideally, 8 rows would be enough to record the accurate coordinates) and the special computation should add less than a second to the time taken for each event. The computer would first compute X and Y from the recorded "elbow" angles, and then the coordinates of the midpoint of slit B (or C) after it has travelled the distance b (or c) in the direction α . Knowing the coordinates of all the raster dots, it will identify the one nearest to the computed point and will use its accurate coordinates to correct X and Y by moving the point (X, Y) in the direction α ; from that it will then compute the coordinates of the midpoint of slit A on crossing the track. Those coordinates will correspond to a point that lies accurately on the track, but whose position along is uncertain by about $\frac{1}{2}$ mm; usually that won't matter.

To measure a point (e.g. an endpoint) that cannot be identified by the photocell behind A one will set that point as accurately as possible on the mark M and then press a button that causes the fixed distance AM to be punched as the value of a. To eliminate the uncertainty across α one turns the box by about 90° and repeats. Fiducial marks in the shape of a cross can be measured accurately by letting α scan over two arms of the cross. The computer programme can see to it that two successive measurements, close together and with the α 's about orthogonal, get combined to give a point that is accurate in both directions.

4. History and acknowledgment

The first proposal for RHODA was made in July 1961, rather in a hurry. A "wash board" was to be used instead of optical bench marks; that would have been hard to make and would no doubt have corrugated the soul of the operator. "Polka dots" were suggested in April 1962, thrown onto the table by a separate projector. Alan Oxley then suggested that a coloured raster should be embodied in the film guide and the film clamped against it, eliminating differential distortion and unsteadiness. At first I thought of a box with no mechanical constraints, containing a transmitter to send out its information, running on dry batteries, and with its position roughly digitized by servo-operated light beams. That could be done and would be very pleasant to use but is more expensive and has been dropped for the time being.

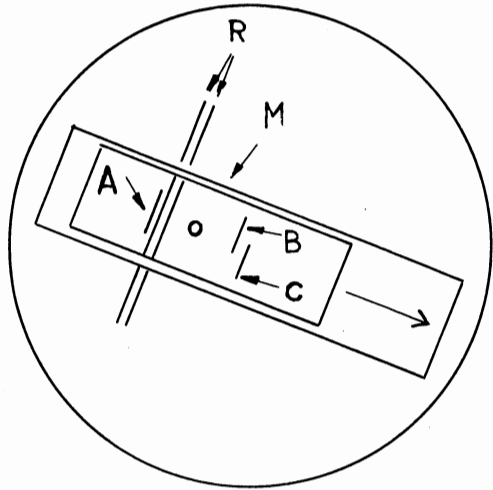

Figure 1

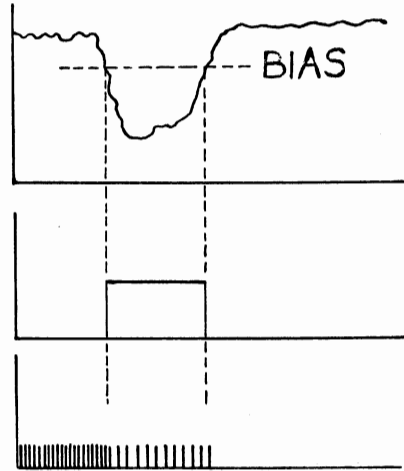

Figure 2

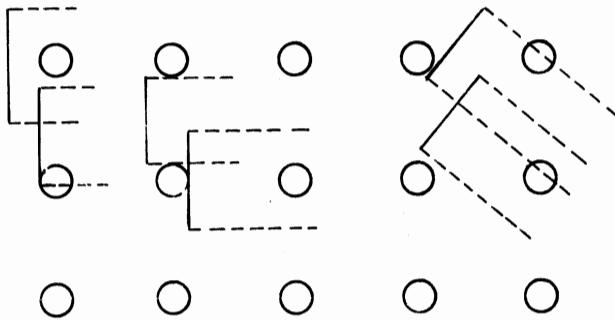

Figure 3

Digitized measuring projector for the
analysis of spark chamber photographs

L.T. Kerth, (Berkeley)

(Note by the editors: the subject matter of Dr. Kerth's communication is contained in the report UCRL-10251 of May 25, 1962 by J.C. Hodges, D. Keefe, L.T. Kerth, J.J. Thresher and W.A. Wenzel).

A point position digitizer based on
magnetic induction

R. Chase, (Brookhaven)

Dr. Chase described a device which could be moved freely over a photograph standing on a mesh of 1024 wires. An operator would just describe a track with the instrument, and the position would automatically be digitised by the position of the curser in the mesh. Preliminary tests with a mesh of 16 wires had given encouraging results, and the work was proceeding.

DISCUSSION

(Communications 12, 13, 14 and 15)

ALVAREZ: Frisch's machine seems to have all of the electronics, mechanical parts, and optical parts of the SMP so I think it will cost about the same amount and have about the same amount of complexity. It seems to have three digitisers; 2 coarse digitisers and 1 fine digitiser. It has all of the attributes of an SMP so I think it is a fine machine but I do not see how it is going to save any money; or how it is going to be smaller or simpler.

FRISCH: Well it does not need the big plate with the accurately-drilled marks. Instead it uses a raster which, I hope, can be reproduced photographically by contact printing and would be cheaper. All the digitisers used, record each of them separately only a moderate number of bits, say ten bits in each direction. It does not need a computer on line. It grinds out its result on the tape and so it can be used by small laboratories which have limited access to a computer but would not have a computer on hand all the time.

ALVAREZ: I think there is a feeling around that an SMP can only work on line. It can certainly work on tape. This, however, robs us of the error correction. Certainly the accuracy of the digitisers is the same in both directions as far as I can see. The problems are the same, the methods of solution are basically the same, they seem to be to be different manifestations of the same basic philosophy and I do not see how the electronics can be very much cheaper. Perhaps they can.

ROSENFELD: The two devices are very similar, so if you decided to put one on line you would probably decide to put the other on line. The real difference is the place you put the bench marks. Frisch's idea of putting them at the back of the film sounds very attractive, on the other hand one does then have to go to two different colours and filters; whereas in the Alvarez system you just mill the thing and that is done.

PARKER: Has Kerth tested his lens using Bureau of Standards cards or some similar device?

KERTH: We frequently use a different lens in the camera because each experiment demands a different magnification. We accept at the laboratory only lenses with a fairly high standard, we have in several cases taken lenses on trial and selected the best ones.

PARKER: The film we use can easily resolve two lines microns apart. I am sure that one can get better films but we have found many quite expensive lenses that could not even resolve lines 30 or 40 microns apart, the sort of errors you are quoting are usually due to astigmatism, and we have to test each lens we get independent of cost.

KERTH: Good lenses are available, but the distortions that we have had trouble with between the projector and the screen usually occur in mirrors, now I also realise it is quite possible to mount mirrors of almost any size as accurately as you like providing you are willing to take the time and trouble in the design stage, and as I tried to indicate we were in a hurry for this device and that is mainly the reason why we felt that we wanted not to have to worry about any more distortions in the optical system than necessary. I think in the next machines that we may build it is quite possible that we will probably still digitise on the film but certainly we will not be so reticent to use mirrors, in that we will have time to do a more careful job on the design and supported mirrors, and so forth.

MCCORMICK: Has Kerth had any experience in measuring the spark chamber film on a Frankenstein device (for example taking two points on each part) and does this compare in time with the other approach in accuracy?

KERTH: In either system the movement of the film to the fiducial line takes the adjustment of two co-ordinates. At present, it is manually operated, but in the next version it may be possible to have it zero on the track itself. In our case in this one operation you get all of the sparks in all of the tracks whereas in the other case you would have to take two

co-ordinates per spark for say 10 sparks, we have not tried it because we felt confident that it was quite a bit slower.

PARKER: Is this 1/4 of a degree which you quote for the same person just moving the curser away and back or is it really putting the film on another time and having another person measure it.

KERTH: The film was actually not taken from the machine. These events that were done were events that occurred at various places during a run. The scanner measured a couple of times at each place on several days - I think a total of five scanners measured these events.

MACLEOD: How long does it take to read out the X and Y-co-ordinates to precision of 1 in 1024?

CHASE: The time scale is determined primarily by the inductance represented by the orthogonal wire rays and by the power that you can make available by the pulsing transistors. In our prototype we find we can make our decision on each bit in 20 microseconds, and we allow something like 100 microseconds settling time between pulses in order that we do not get paralysis problems with our amplifier, so that with 22 pulses of 100 microseconds spacing it takes us about 2.2 milliseconds for digitising. In 2.2 milliseconds the scanner can not move the curser very far.

Hardware development at the Rutherford
Laboratory

B. Burren, (Harwell)

SUMMARY

B. Burren talked of the development of a flying-line device which would scan with a line of dimensions $1 \text{ mm} \times 20 \mu$, giving about 30 scans per mm. The information resulting would be much less than with the HPD, though in other hardware aspects, the machine would be very similar. Encouraging results had been obtained on tests, and photographs were shown of the sort of signals produced.

The programming problem was formidable but some use could be made of present programmes and techniques.

"Chloe"

A system for the automatic handling of
spark pictures

J.W. Butler, (Argonne)*

1. Foreword

The system to be described was conceived by Donald Hodges and myself in the early part of 1961, and has since been designed and constructed by an engineering group led by Hodges with software assistance by Richard Royston. Substantial support and encouragement were provided by the High Energy Physics Division of the Laboratory, particularly by Roger Hildebrand. The equipment is now operating but has not been put through the usual tidying up and debugging process necessary to produce a productive system.

2. Introduction

The evolution of this particular design was guided by three circumstances which obtained at about mid-1961.

Firstly, advances in cathode ray tube and fiber optics technology were occurring at a rate such that we could confidently expect suitable tubes to be available by the time they were needed. A firm decision was therefore made to concentrate our efforts in this area and avoid consideration of various types of mechanical scanning schemes. The correctness of this decision has been borne out, since good tubes are now obtainable from several manufactures.

*)

Work performed under the auspices of the U.S. Atomic Energy Commission.

We are now writing a program which will enable us to attempt the processing of data from an actual spark chamber experiment, but not enough has been done to justify discussion at this time.

6. Acknowledgments

It is a pleasure to acknowledge the contributions of Robert Conderohe to the CRT circuit development and the able assistance of Richard Wehmann in design and construction of the entire system.

- 1) Arthur Roberts, "Review of Scientific Instruments" 32, 531 (1961)
- 2) Advanced Scientific Instruments, Inc., Minneapolis, Minnesota.
- 3) Private communication from L. Leipuner (BNL) to Arthur Roberts (ANL), August 1961.

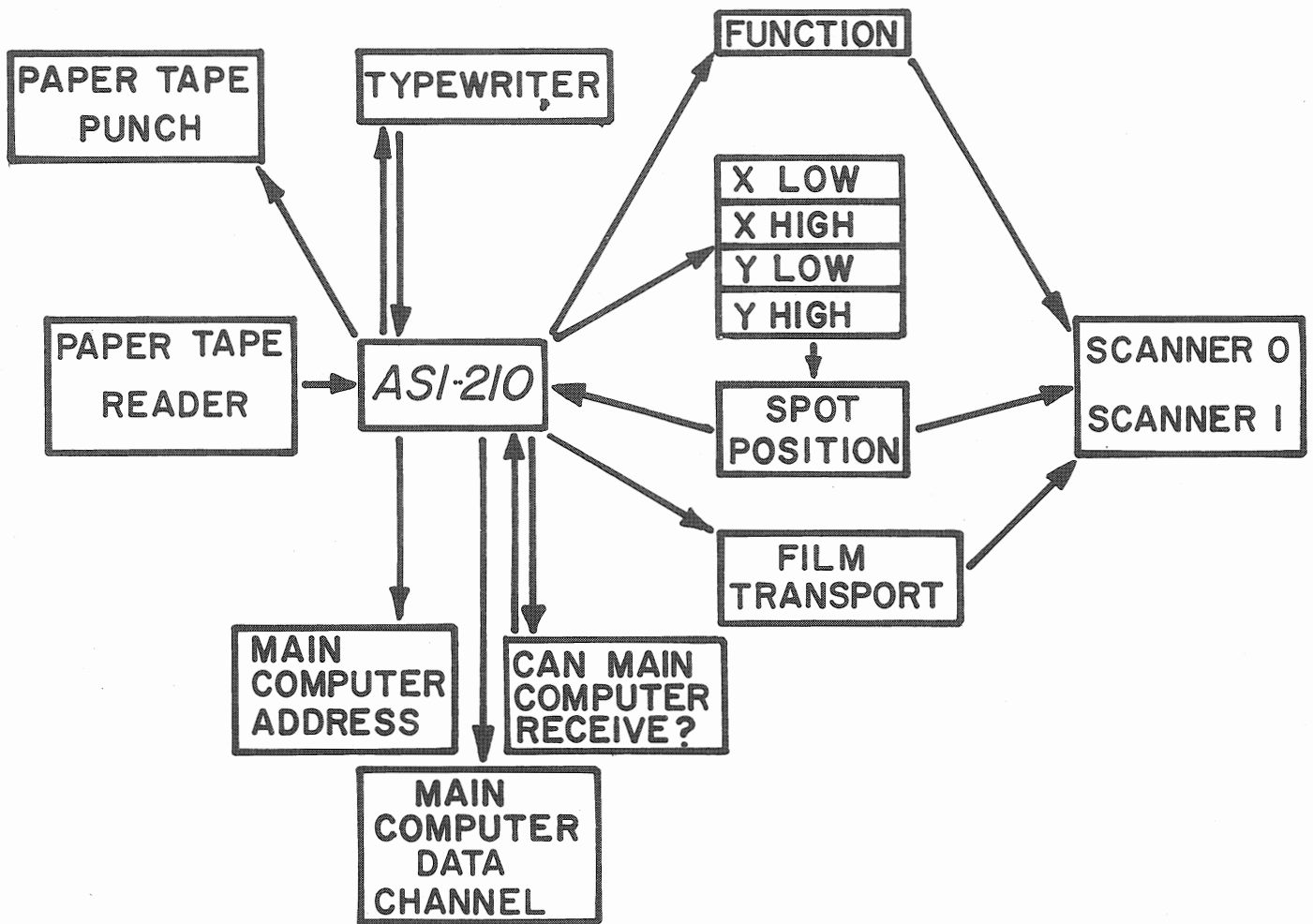

Figure 1

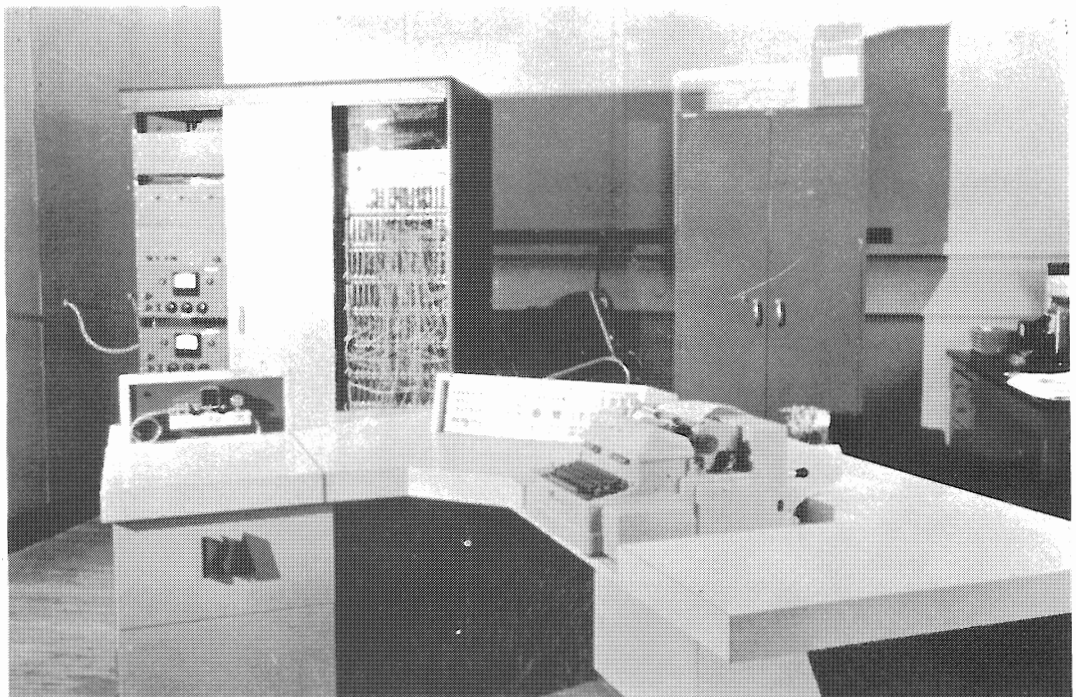

Figure 2

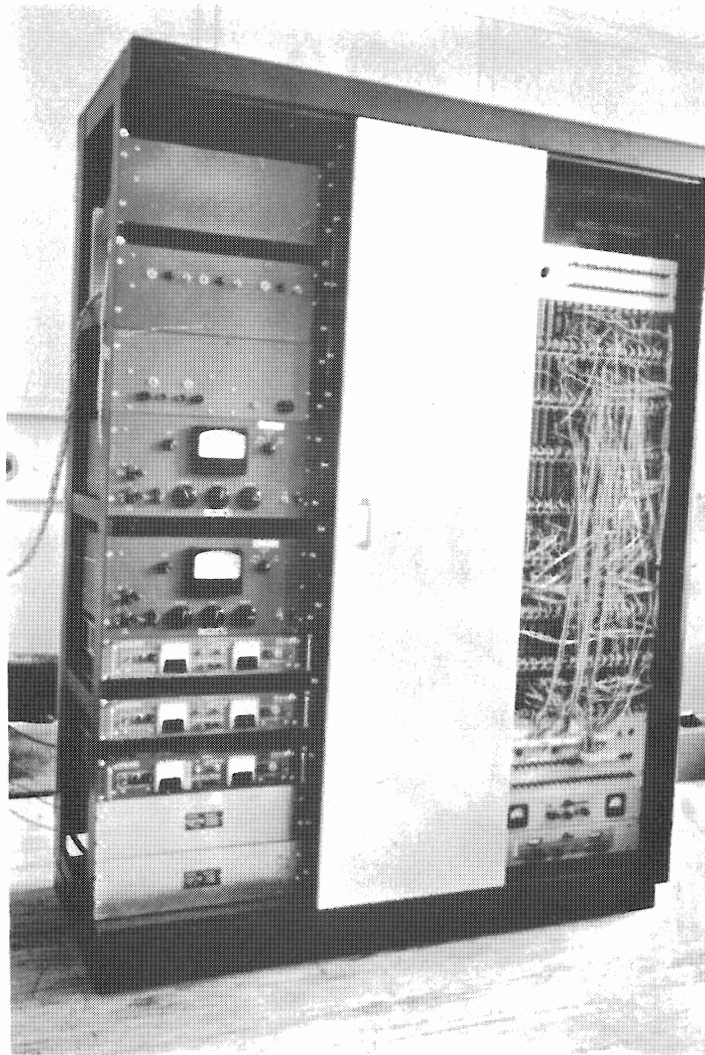

Figure 3

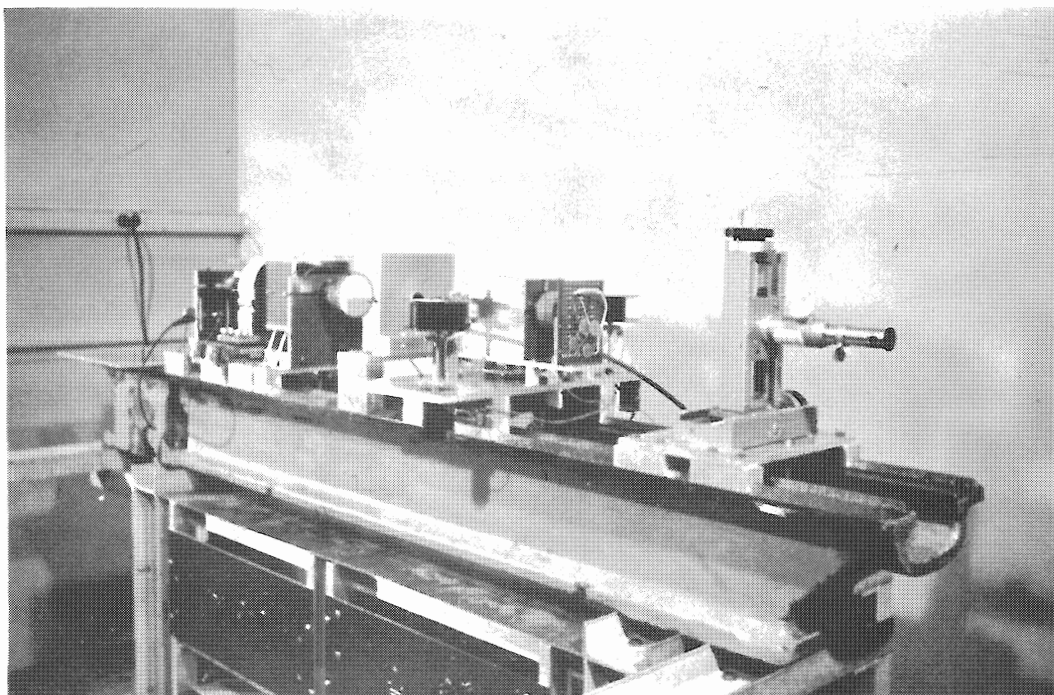

Figure 4

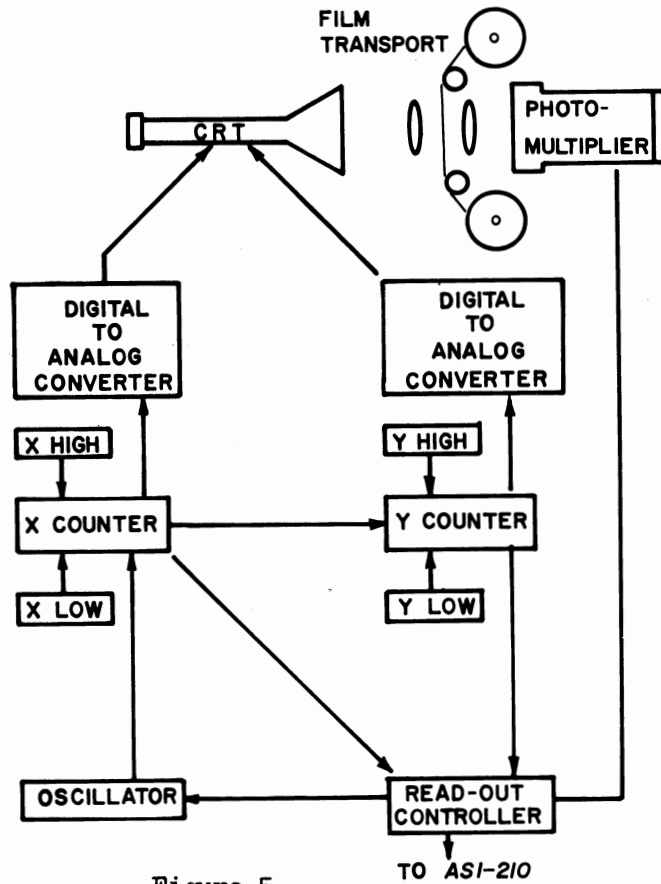

Figure 5

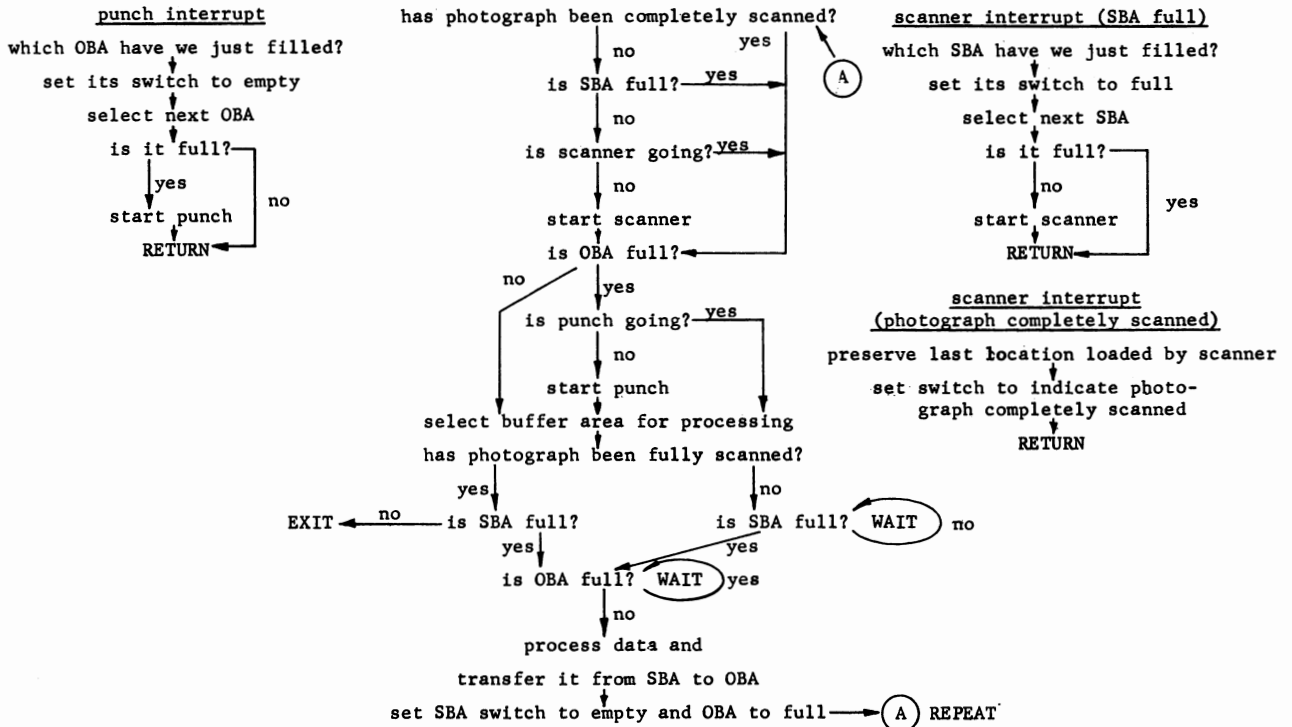
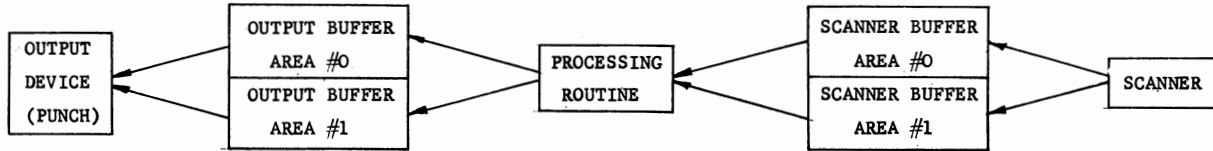

Figure 6

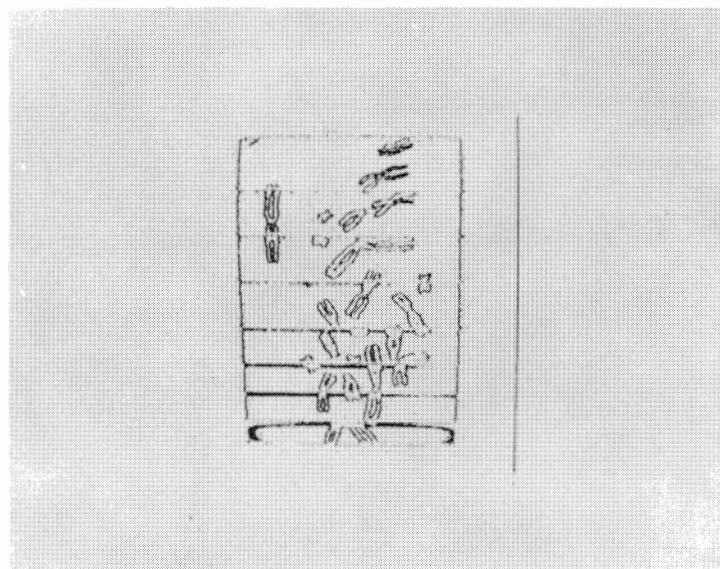
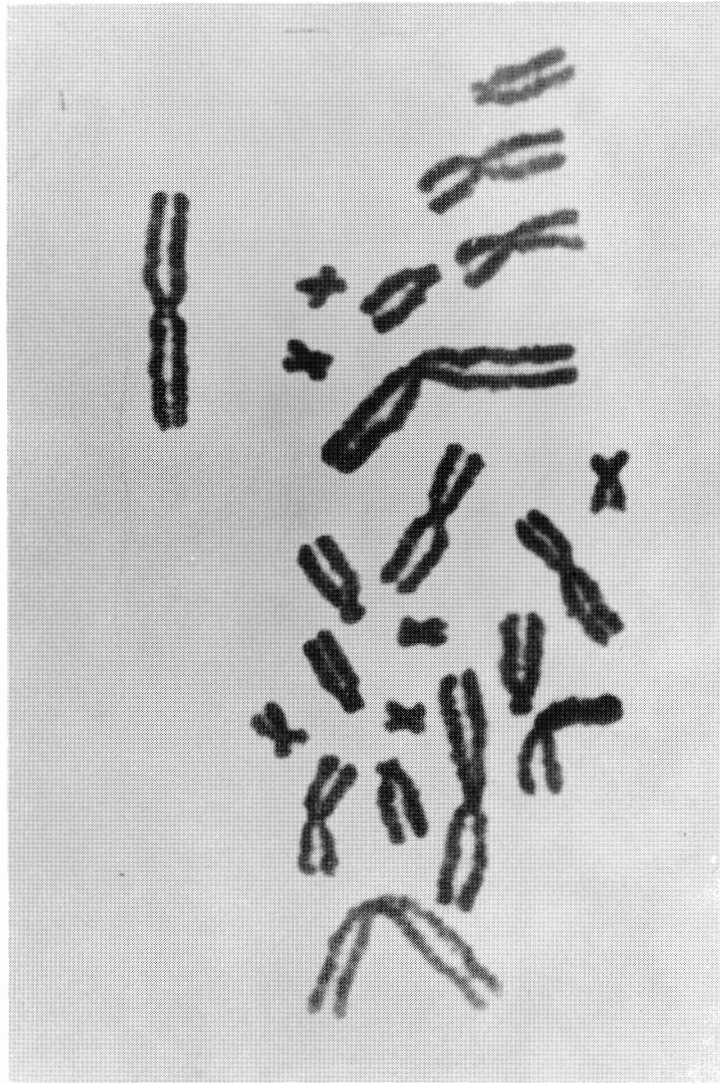

Figure 7

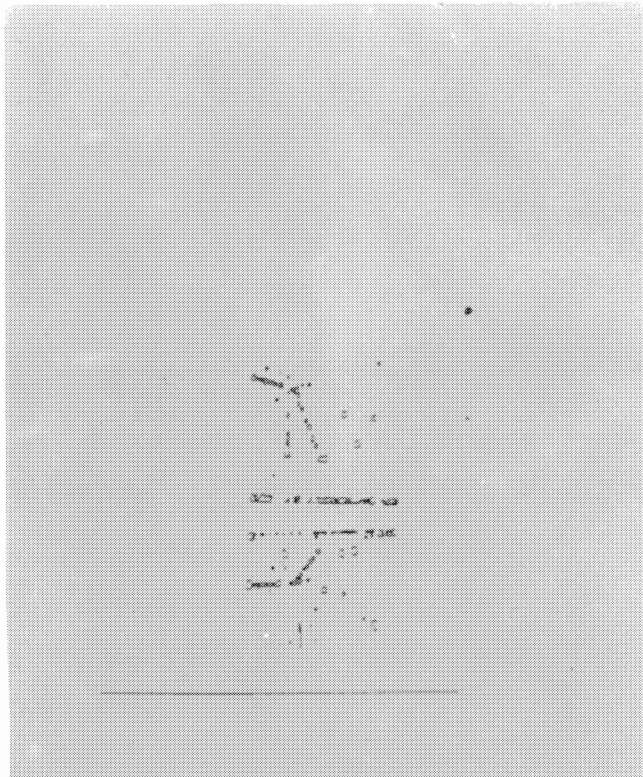
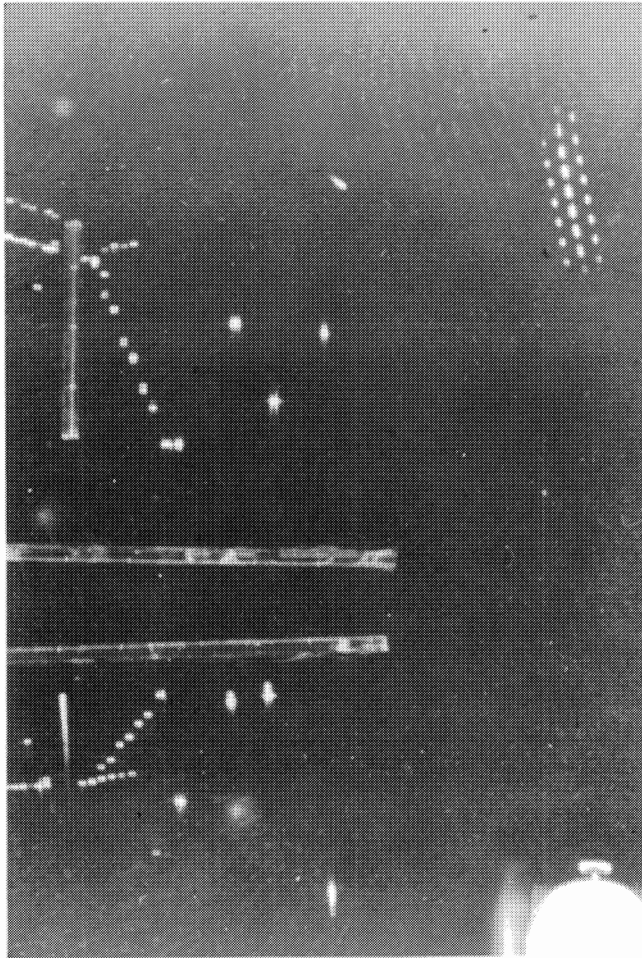

Figure 8

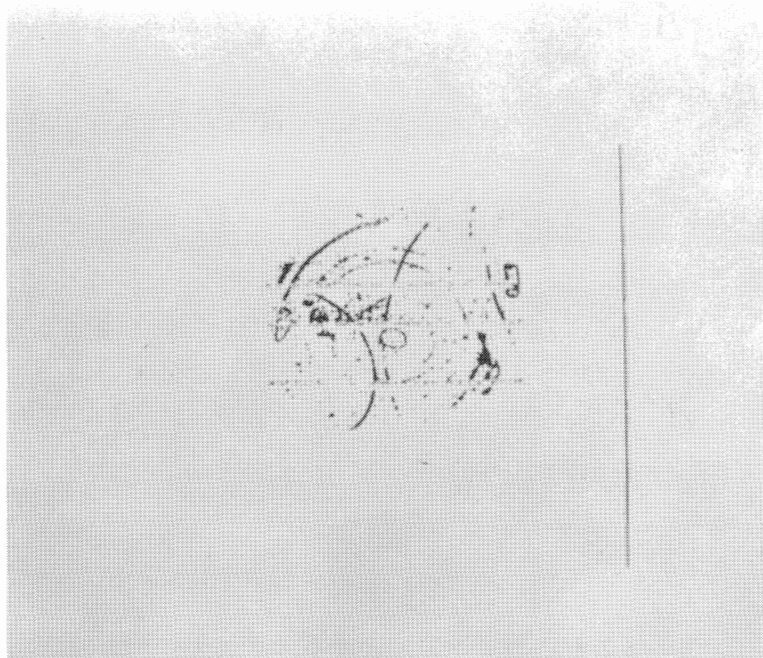
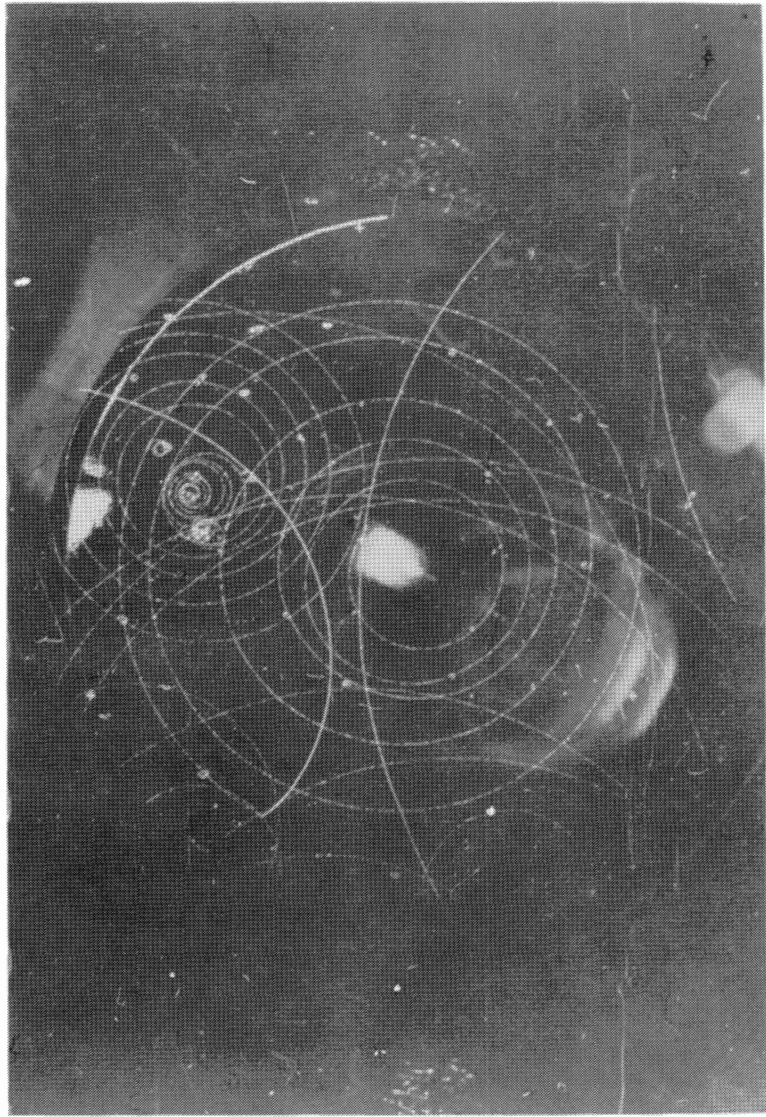

Figure 9

A description of the PRU device

B.H. McCormick, (Urbana, Ill.)

(Note by the editors: a paper on this subject was submitted to the Instrumentation Conference, held at CERN on July 16 - 18 and is included in the Proceedings of that Conference, to be published shortly in "Nuclear Instruments and Methods". The Informal Meeting of July 19 offered the author the opportunity for a more detailed presentation and discussion).

A scheme for automatic processing of bubble chamber
and spark chamber photographs

A.R. Edmonds, (London)

The report which follows is a brief account of the present state of work which has been carried out at Imperial College over the last eighteen months. It is a sequel to two previous reports (May and November 1961) by the present author.

As to the state of the project: detailed design and drawing of the mechanical and optical parts were started some time ago, and experiments to test some aspects of the mechanical design are at present being made. A large part of the work has been a study of the properties of commercial computing and data processing equipment with respect to the track measuring problem.

1. Study of the system

The current assumption is made that the film processing system may be taken to consist of three connected parts, viz: (i) the human scanner equipped with a suitable picture-projection device and possibly with facilities for rough measurement of events, (ii) an automatic machine which measures selected events sufficiently accurately according to the instructions of the computer and scanner, (iii) a computer which selects the relevant information from the output of the measuring machine and processes it in various ways for spatial reconstruction, kinematical fitting, etc..

It is immediately evident that one of the objects of research must be to decrease materially the extent of human intervention i.e. to lighten the task of the scanner, if not to eliminate this stage in suitable circumstances.

The properties of the computer required in this system are particularly important. We must consider the size and speed of a computer which may be expected to cope with the various processes involved at a satisfactory rate; something of the order of several events a minute is generally accepted as desirable. The following discussion takes into account conditions prevailing in the United Kingdom; however, it is hoped that some, at least, of the conclusions may have a wider relevance.

Plans are being made by the bubble chamber group at the Rutherford Laboratory, Harwell, to use a Hough-Powell type measuring machine with the output fed directly to a Ferranti Orion computer. In approximate terms the Orion is equivalent in speed to the 709, although it has many more advanced features.

It has been known for some time that the 7090 rather than the 709 (a factor of about six slower) matches the natural speed of the Hough-Powell system. The Brookhaven group, led by R.P. Shutt, have reached this conclusion. They already have an IBM 7090, and up to two shifts per day can be allocated solely to bubble chamber work. They plan to use most of the time with a Hough-Powell input during 1963. It has already been agreed, however, to replace the 7090 by a 7094 which is somewhat faster (probably a factor of 1.5 to 2). Embryonic plans are being discussed for a much larger and faster computer. If pattern recognition problems are to be tackled in the future, then it is essential that a very large computer be part of the overall measurement system.

It is pertinent to inquire if any time on a very much faster machine than Orion is likely to be available in the U.K.. The only attractive possibility appears to be Atlas. The present author has studied the technical problems involved in connecting a measuring machine to one or other of the three Atlas machines (Manchester, London, N.I.R.N.S.). Consultations have been held with Atlas experts at Manchester University and with Ferranti Ltd.. It appears that the supervisor programme being supplied with the normal Atlas operates in such a way that all the data for a given computation must have

been read into the computer and stored on magnetic tape before the computation in question can start. With this system it is clearly impossible for the computer to control the measuring machine in any manner; for example, it could not require more careful measurement of the coordinates from one particular scanning line after having made a first study of the data. It is, of course, possible but very inconvenient to alter the Atlas supervisor programme which is located in the fixed store. One then discovers, however, that Atlas in its present form is unable to accept input from any external device other than at a rather slow rate^{*)}. Ferranti Ltd have stated, informally, that a fast rate of input of 10^5 to 10^6 bits per second might be attained by the addition to Atlas of a special unit resembling the present magnetic tape coordinator. This special purpose unit might cost about £ 250,000 and would take several years to develop. Facing this rather unpromising situation led the author to consider the possibility of carrying out the first stage of processing information in a special data-handling device which would prepare a suitable output, preferably paper tape, which would become an input for Atlas to handle the bulk of the calculation, namely, geometry, kinematics and sorting of events using its time sharing facilities. For example, if the device is capable of selecting the measurements relating to the event of interest and processing the track coordinates so that each track may be represented by a smoothed set of points, a typical event may be encoded as rather less than 10,000 bits. This amount of information would be output by a Creed type 3000 fast paper-tape punch in a few seconds, and read into Atlas in a similar time. Although transfer of information to Atlas via magnetic rather than paper tape would have obvious operational advantages, the above argument shows that it is not essential; a magnetic tape deck and

*) Since the date when this paper was presented further study of this problem by Ferranti has yielded a solution which will permit a high data rate for direct input at a significantly lower cost. - Editors.

associated electronics might cost around £ 20,000. It should also be noted that the paper tape scheme referred to would have built-in error detecting and correcting facilities.

The data-processing unit would have to satisfy a number of requirements for the combined system to be equivalent to computers such as the IBM 7090 or 7094. The most important of these is that rapid input of information from the measuring machine should be possible, preferably in such a manner that normal computation is not impeded. The memory of the device must be large enough to accommodate both the processing programme and input and output buffer stores. To keep the size of the memory (and hence the cost of the device) to a minimum the operating speed must be very high; otherwise there will be a need for undue amounts of buffer storage. Finally the cost of the device must be small compared with that of one of the usual large computers.

A number of small computing devices intended for real-time data processing have been developed in the last few years in the U.S.A. and in the U.K. and these have been considered with the above application in mind.

Several such machines are currently available in modest versions (4 - 8000 words of core store) at prices of the order of £ 50,000; more than one of them seems a likely candidate for the job.

Although the original impulse to consider a small intermediate data processing unit arose from the problems of working with Atlas, it is possible that such a philosophy may have advantages even with large computers with less restricted facilities for rapid input and output of data. A small relatively cheap device may more easily be monopolized by a development programme, and in any case such machines are specially designed for real time multi-channel operation.

2. The proposed measuring machine

A data-processing system of the type just described will impose certain conditions on the design of the associated measuring machine. We may assume that the amount of fast storage is limited and that no tape decks are directly available to the small computing machine. This makes it advisable to process all 3 or 4 views concurrently, though this is probably also an advantage when only one large computer is used. The measuring machine should be operated in such a way that it can, on command, wait for the data processor to digest the last block of input before attempting to measure further. The possibility of re-measuring would be valuable. The measuring machine should also be designed in such a way that it can take advantage of the sophisticated control capabilities which are characteristic of these real-time computers.

A machine with the above properties has been sketched out (figure 1), and mechanical and optical design is well advanced. It is essentially a flying-spot scanner which covers the photographs line by line. The most radical feature is its cylindrical symmetry (figure 2); the 3 or 4 films associated with the different views are sucked down onto the surfaces of parallel glass plates each about 220 mm long. The surfaces of these plates lie on the same cylinder, with radius about 170 mm and axis parallel to the length of the films. The film carriage is designed so that 35, 50 or 70 mm film may be accommodated. The film transport system is expected to be similar to that now being developed for the Rutherford Laboratory. The films are scanned by twelve spots of light emitted radially by a rotor whose axis coincides with that of the cylinder on which the films lie. Relative motion of the rotor and film carriage allows for the scanning of the whole of each frame. Condensers and photomultipliers are positioned behind the films to pick up the transmitted light.

The twelve spots of light are produced by twelve radial optical projection systems. Each of these systems consists of a pentaprism, an adjusting lens and a modified microscope objective of N.A. about 0.25. Light from a collimator is led into the rotor through a ring of twelve portholes in the side, and turned through 90° by each of the pentaprisms.

Successive optical systems are adjusted so that the spots travel over twelve separate lines about 20 microns apart, thus covering a strip of the films about 240 microns wide. The size of the spots produced on the film may be varied down to a diffraction-limited minimum of about 2 microns. The optical system wastes relatively little of the light and very high scanning speeds are in principle possible without much reduction of signal-to-noise ratio. It will be seen that this arrangement of scanning spots presents a number of advantages when it is remembered that the intention is to measure the films with the rotor and films at rest with respect to relative axial motion. It is, for example, possible by programming the measurements, to select tracks with particular orientations to the direction of scan, and to deal with tracks lying nearly parallel to this direction. Thus no measures need be taken to supply an orthogonal scanning facility, as in the Hough-Powell scheme.

This cylindrical symmetry implies that measurement of distance across the film may be replaced by measurement of instantaneous angular position of the rotor. This angular position moreover would have to be measured to a very high degree of accuracy to secure the precision required, (of the order of 2 microns on the film). But by careful mechanical design we can ensure that the rotor runs at a very constant speed. Measurement of position is then replaced by electronic measurement of time intervals, which is easily achieved by modern techniques. If the speed of the rotor is monitored at frequent intervals and the result fed into the data-processor, it is not necessary to require absolute precision of speed or long-term constancy. A very constant speed over short periods of time is adequate. The alternatives of mounting the rotor in oil or air hydrostatic bearings are at present being investigated, and experiments to check the constancy of speed obtainable are in progress. Such bearings offer an additional advantage; the axis of the rotor may be located with a high degree of accuracy without the need for unusually precise methods of fabrication. In spite of certain advantages of air bearings, it is likely that pressurized oil hydrostatic bearings will be chosen. High pressure oil will in any case be needed for a hydraulic ram, and the very high stiffness obtainable with oil bearings, often greater than 100 kg/micron, means that it

is possible to move the rotor with respect to the main frame, rather than the film carriage. This offers several practical advantages.

The philosophy of measurement associated with the use of a small data processor leads us to favour start-stop operation of the axial motion of the rotor relative to the film.

The rotor carriage is to be mounted on linear hydrostatic or roller bearings and moved back and forth by an hydraulic ram, under control of an electro-hydraulic servo valve. The relatively high accelerations (several g) needed for reasonably fast start-stop operation demand a counterpoise system for the moving carriage (figure 3). The preliminary design work for this has been completed. The intention is systematically to measure all 3 or 4 films together, measurements being done while the rotor carriage is at rest. On completion of a set of measurements, a signal from the data processor causes the rotor carriage to move on to a new position. The corresponding coordinate is read of the counter of a linear moiré fringe grating into the data processor. The maximum speed of the linear motion would be of the order of 200 mm/sec.

3. Associated electronics

The work already done has produced a scheme which although quite feasible, is too complex to describe adequately in a brief report. A few features may, however, be of interest. One principle adopted is to convert the photomultiplier outputs into digital form at the earliest opportunity. This gives several advantages; standard commercial logical packages may be used on a large scale, and a great part of the system may be independent of the rate of operation of the measuring machine. A figure of 2,000 r.p.m. for the rotor has been considered, but it may be profitable to vary this considerably. The problem arises of how to carry out rapid analogue-digital conversion? The answer to this is probably the use of tunnel diodes. Experiments in this direction are in progress at Imperial College.

The general scheme will have similarities to the Hough-Powell philosophy; however there are a number of differences. Since no provision is made for a scan in the axial direction, the system must be able to deal with signals representing tracks making a small angle with the line of scan. The small amount of core storage assumed in the data-processing device makes it necessary to have a highly efficient procedure for rejecting signals arising from unwanted tracks. It is believed that these requirements are taken care of in the proposed system. An important feature is that the digitizing circuits are to be constructed so that the system will work over a wide range of scanning speeds. In this way it is hoped to be able to make a best match between the measuring machine and the data-processing unit. The rate of processing of events will probably be limited first by the speed of operation of the film transport and the rate of punching of paper tape: 10-20 seconds per event is contemplated. This should leave plenty of computing time available for elementary pattern recognition operations which may eventually reduce the amount of preliminary information (the "rough digitizations") to be supplied by the human scanner.

The data-processing device will have another function; namely, the control of the hydraulic servo-system which moves the rotor carriage in the axial direction. Measurements are made at rest and choice of scanning lines on the films (three or four at once) is made by programme according to immediate requirements. The total flow of information into the device is thus reduced to the minimum necessary. The engineering design of the measuring machine will make the time lost while the rotor carriage is moving a matter of milliseconds; with the above scheme a hundred steps per event will probably be adequate. The staggering of the lenses in the rotor, mentioned earlier in this report, will make fine adjustments of the axial coordinate unnecessary.

The recording of track signals while the rotor carriage is at rest has certain practical advantages (c.f. the Hough-Powell system). For example, it would be expensive to equip the data-processing device with sufficient

core storage to be able to buffer the numbers of digitizations arising under exceptional circumstances (e.g. large numbers of beam tracks, tracks parallel to the scan). With our scheme, however, overflow of the buffer region may be detected, causing entry to a special subroutine which processes the data already in the buffer, and carries on measurement at an appropriate point on the next available scan. Thus, we can save on fast storage in return for a somewhat more elaborate engineering design of the measuring machine and possibly a longer time for processing exceptional cases. Conversely, processing may be speeded up significantly when simple patterns have to be dealt with (e.g. spark chamber photographs). In such circumstances, a few dozen steps of the rotor carriage may be adequate.

4. Conclusions

The design study already carried out demonstrates that a high speed film measuring system can be built without the necessity for the measuring machine being on-line to a very large and expensive general purpose computer. The proposed scheme will be at least as fast as the Brookhaven Hough-Powell system using the IBM 7090 and probably as fast as the IBM 7094 system. It will, however, be much more flexible in several aspects; for example, a wide range of scanning speeds will be readily available and the selection of axial coordinates can be programmed efficiently.

The proposed system should be considerably more economic than the Brookhaven scheme since the on-line computer is probably much less expensive than using part of the large IBM machine. The use of a large computer also limits the way in which one uses the measuring machine because it is uneconomic to waste the large computer's time. It has been indicated that the time required for measuring 3 or perhaps 4 stereo runs of an event will not be longer than about 20 sec. and in simple cases may be significantly shorter. A few seconds - say up to 5 - of Atlas time will be needed to complete the remaining stages of the calculation - namely, geometry, kinematics and sorting.

This time, however, can be obtained using the normal time-sharing arrangements for Atlas.

It may also be noted that the proposed system can undoubtedly be used for the evaluation of some kinds of spark chamber pictures. Development work on this problem would also be included in the programme for the machine.

In the early years of the project a considerable amount of operating time with the measuring machine and small computer would need to be devoted to development work with the aim of reducing considerably the amount of work to be done on the scanning table. Thus we envisage the system being used as soon as possible for some production measurements, but most of its time would be used for research work on the development of the technique.

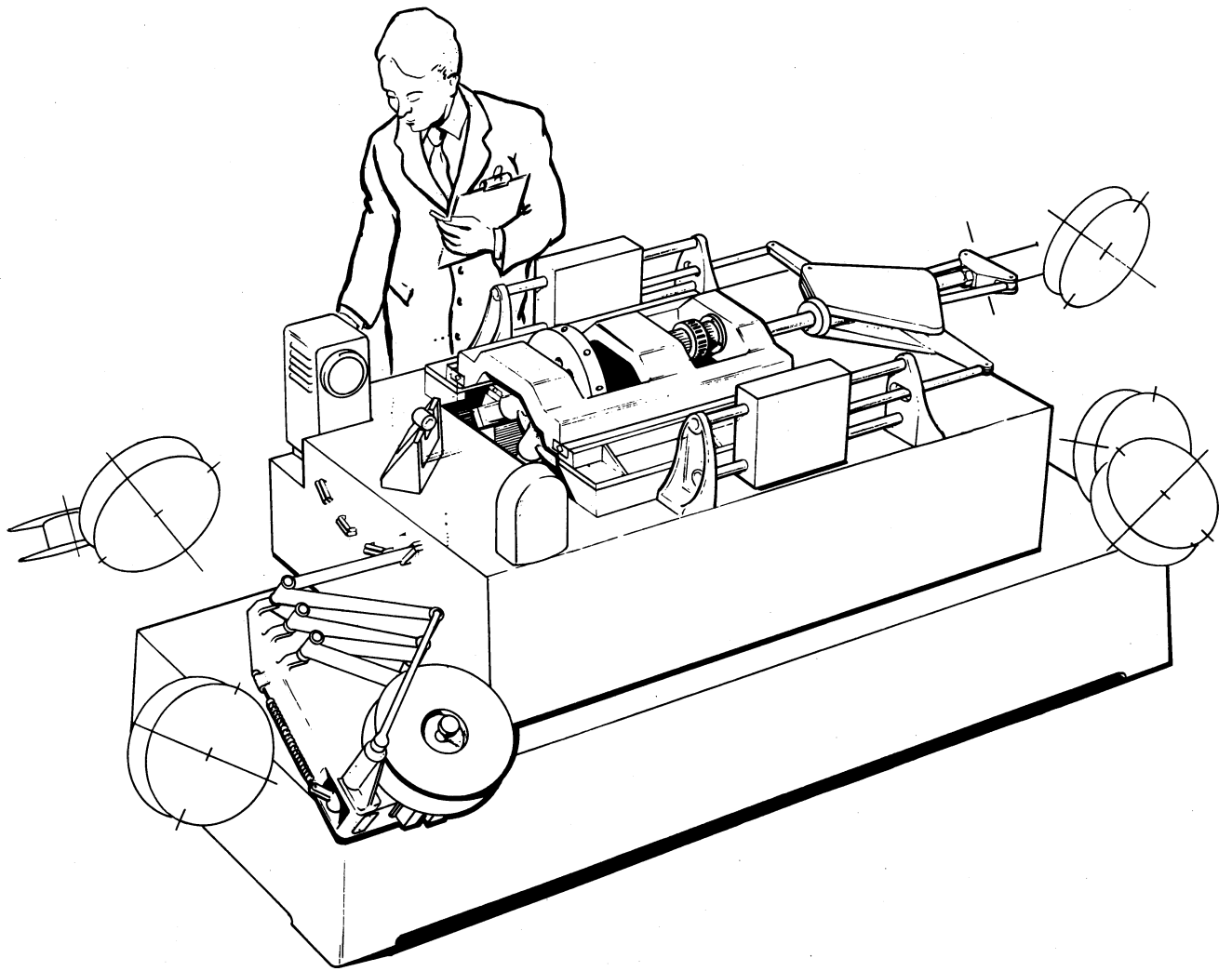

Figure 1

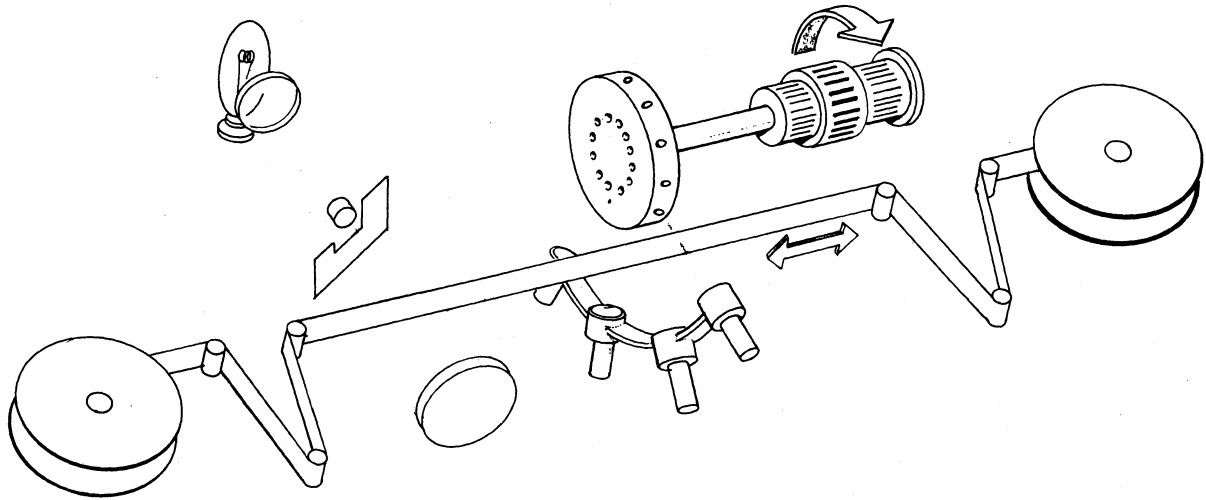

Figure 2

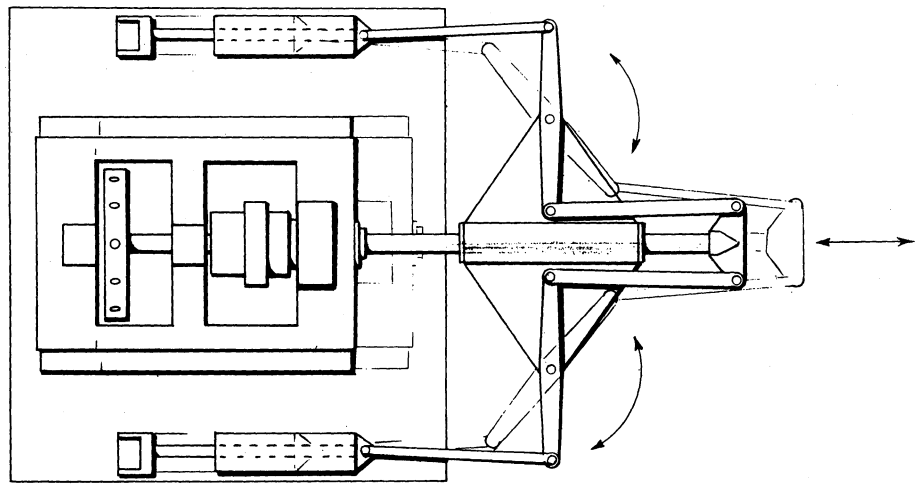

Figure 3

DISCUSSION

(Communications 16, 17, 18 and 19)

ROSENFELD: I would like to ask McCormick when will this machine be ready to use?

MCCORMICK: The time scale depends largely upon financial questions. When those are resolved I will be willing to quote a time.

WELFORD: With Dr. Butler's system the cathode-ray tube is imaged by a lens on to the film in his scanning device and yet it is a fibre-optics tube. Can you say what is the purpose of the fibre-optics?

BUTLER: We bought the fibre optics because we want to eliminate the lenses but we are not quite ready to face the problems that go with running the film directly against the tube.

MACLEOD: Edmonds said that it was an advantage to be able to measure stereoscopic views in parallel. Even on a large computer it is not obvious that this is an advantage, and on a small computer I should have thought the high data-rate would definitely counter-indicate it.

Secondly, why does scanning the picture in bands of 12 lines remove the need for orthogonal scanning? Thirdly, what sort of measuring times does he expect with this machine? Fourthly, could he say in a little more detail what kind of processing he proposes to do in the small computer before hand-over to the large one.

EDMONDS: The advantage of working in stereo is primarily associated with cross referencing between different views, and the possibility of re-measuring an event immediately if it fails. Now, if you have one big computer and you have recorded the digitisations from each of your three views on three separate magnetic tapes then it is a relatively straight forward business to run these tapes back and try the whole thing again.

The small computer should deal with the problems of gating the information which comes in. It would select from the input information the digitisations belonging to the tracks we were interested in. It would put these digitisations together in the sense of making lines out of them and then replace these lines by numbers, possibly just in the form of a sequence of co-ordinates or chosen points along the lines. The eventual output would be rather similar to what J. Burren calls a Tape A. The main idea is to absorb the information from the measuring machine and control it.

MACLEOD: The most advanced programming techniques for this are those being developed at Brookhaven and so far they have been able to produce a programme which would just about keep rate with one measuring machine measuring one view. I do not see how, with a small computer which is much less powerful than a 7090, you can hope to process three views simultaneously.

EDMONDS: The small special purpose computer is designed for the job, it is not just a cut-down version of the 7090. Some of these machines have facilities for micro-programming which the 7090 does not. They are designed especially to deal with information in this fashion rather than to do floating-point arithmetic. The fact that we are measuring our three views all at once, does not necessarily mean that the machine has to run three times as fast as one HPD will. We have to match the speed of this machine to the small computer and this is something that we will find out in due course. The basic reason for the small computer is not that the small computer would be better than the big one. Rather that in England we are faced with the likelihood of having three Atlases and one of their properties is that they are very bad at taking in large amounts of information. We are therefore looking for a possibility of making use of these big machines for this kind of work, and the small computer is a possible way of doing it. There are other obvious advantages of a small computer e.g. if we are doing development work with a measuring machine on a small computer we have the machine to ourselves, we do not have to share it.

WISKOTT: What is the advantage of having a two micron flying spot?

EDMONDS: There is no particularity advantage at the moment. The main point is that because of the optical design, the spot can be chosen so as to be anything down to 2 microns.

I have done some experiments on a flying-spot scanner at Imperial College on varying the spot size and I believe that there is some advantage in having a spot appreciably smaller than 10 microns, particularly in the case of certain types of film. My view is that the spot size should be a variable parameter, that one should not be limited to a rather large size of spot as one would be with the cathode-ray tube system, or as I believe one would be with the HPD.

WELFORD: I would like to reply more fully to the question on spot size. If you have a spot image which is limited by diffraction and possibly aberrations in the lens, then for the same intensity of source, the amount of light you get in any size of spot is the same. If you decrease the spot, it is formed with a larger cone. If you make your optical system able to give you a diffraction-limited spot of 2 microns instead of 10, then you can increase your original pinhole to the equivalent of 10 and then you have 25 times the amount of light flux that you would have had in a 10 micron spot which was diffraction-limited.

POWELL: I believe that in England there will be a number of KDF 9 computers. Would that be easier to operate with the advantages of a large computer.

EDMONDS: The answer to that is this, and I have checked on this with English Electric. The KDF 9 does have an interrupt facility and one could use the KDF 9 reasonably conveniently for direct input. It probably wouldn't be as efficient at direct input and output operations as the small machine would. It would probably be not as good as a 7090 but much better than an Atlas.

The drawback is that the KDF 9's on order are very cut-down versions. They have 8,000 words of core store and I think they have only two tape decks.

Thus, as they stand, they are too small to substitute for an Atlas.

The advantage of the small machines for this application is that they are specially designed for real time working, for working with short words, for doing logical operations, for in and out operations and for working in the interrupt mode, and they are just a cut-down version of a big computer. They are very much more flexible. For example, the RW 530 has micro-programming facilities available. This gives the customer the option to a large extent, of establishing exactly what the computer does, and exactly how the individual instructions work. With the small machine, you pay a relatively small amount of money for the parts of the machine you need and you do not have the rest of the equipment standing idle.

BUTLER: One comment on the RW 530. It is a very interesting machine but I think you pay quite a steep penalty for getting this micro-programming facility. A rough analysis showed that by linking two computers together, you have two arithmetic units going at once on the same problem and this is a fairly powerful combination.

ROSENFELD: I would just like to know how much this ASI 210 costs and perhaps how much some of these machines you are suggesting, the small special purpose machines, cost.

BUTLER: The ASI 210 with two "in-out" channels costs \$117,000. We do not have a tape unit but we have direct data connection into the larger computer. We have nothing but a typewriter and a paper tape for programme input.

MACLEOD: I would like to ask Dr. Butler what is the scanning pattern developed on the scanning tube of his device, as I understand it can be varied under computer control as far as the area of film that it covers but I have not properly understood whether the computer can vary the scanning patterns itself.

BUTLER: We have arranged the scanning pattern to be simply left or right and then start on the next line. It costs you quite a bit in time to have to address each point-transmitting an instruction from the computer; we can do it if we like by just setting the upper and lower limits to be one different. We can hit any point we like but this is rather slow.

MACLEOD: What is the time taken for one complete serial scan?

BUTLER: As I said, the oscillator runs at 100 kilocycles so that is the time it takes to develop each spot in microseconds.

WISKOTT: I would like to ask Dr. Butler whether the deflection circuitry of his cathode-ray tube was sufficiently linear, or whether some calibration was always necessary.

BUTLER: We have not measured this yet, so I cannot answer that question.

Concluding remarks

L. Kowarski, (CERN)

At the close of this one-day meeting it is appropriate, first of all, to thank all those who came and contributed; one would like to do something more - to summarize in a few words the gist of what we have heard and learned - but this does not seem to me easy. One obvious remark is that the subject matter of to-day's proceedings is not homogeneous in time. We can already speak of a first generation - hardware which, at present, is in actual use; a second generation, in the state of advanced development; a third one, almost wholly in the future, and even one or two intermediates.

The first generation - the actual use of Franckensteins, Ieps and so on, was mentioned in the first part of the morning session. The experience reported was programming experience and it gave a rather terrifying glimpse of the amount of work which goes into straightening out seemingly unimportant details. In fact each of these details is quite essential for the quality of the scientific output; this means that we shall have to hire more and more programmers. Here, as in many other things, Berkeley shows the way and the figures which were quoted by Rosenfeld in his paper at the Instrumentation Conference are instructive enough.

In the second part of the morning session the two main contenders - or should we say colleagues? - of the second generation made their appearance side by side. Both of them pursue the same aim - to solve the problem of man vs machine (or, rather, the scanning and measuring girl vs. machine) but their ways of approach are diametrically opposed. HPD segregates, SMP combines; the first results of these two lines of development, both of which have by now been well launched, will be fascinating to watch. For what a prophesy at this level may be worth, I think we shall find that they both will be useful in their separate and even slightly diverging ways, HPD holding its own in high-statistics research, and SMP being particularly valuable in cases where the events show a more pronounced individuality.

Some physicists, in the recent past, felt that they could not wait for the second generation to become fully operative, and endeavoured to improve on the first generation in a less radical way. Of this "generation 1 $\frac{1}{2}$ ", the Spiral Reader is the most advanced and the most conspicuous example; we heard this morning from Alvarez about the results obtained with this device. Later on, Brautti described a European variant of essentially the same approach and, as we heard on another occasion this afternoon, European versions usually are cheaper than their American counterparts. Kerth's proposed addition to the digitized projector technique is an interesting improvement, based on a specific property of spark chamber pictures.

The contributions of Chase and Frisch belong definitely to the second generation, Chase's scanning table being intended to work as a part of a Hough-Powell system and Frisch's travelling box being essentially a European (we have seen what that means) version of the SMP. Both Burren and Edmonds seek to decisively improve on the HPD and therefore merit the label "generation 2 $\frac{1}{2}$ ".

Finally, in the second part of the afternoon, we heard from Butler and McCormick about pattern-recognizing machines; a third generation is on its way, and already we hear a warning. The old dream of "let the computer worry" may require an entirely new kind of computers, and who shall worry then?

Many interesting results and ideas, some serious warnings; with all these in mind, we shall go on working, and such is life.

LIST OF PARTICIPANTS

ALVAREZ, L. Lawrence Radiation Laboratory
BRAUTTI, G. University of Trieste
BURREN, J.W. Rutherford Laboratory, Harwell
BUTLER, J.W. The University, Argonne
CHASE, R. Brookhaven National Laboratory
DERRICK, A.H. Lawrence Radiation Laboratory
EDMONDS, A.R. Imperial College, London
FRISCH, O.R. Cavendish Laboratory, Cambridge
HOUGH, P.V.C. Brookhaven National Laboratory
HULSIZER, R. Lawrence Radiation Laboratory
McCORMICK, B.H. University of Illinois
NIKITIN, S.Ya. Institute of Theoretical & Experimental Physics, Moscow
PARKER, S. The Enrico Fermi Institute, Chicago
ROSENFELD, A.H. Lawrence Radiation Laboratory
SELOVE, W. University of Pennsylvania
SNYDER, J.N. University of Illinois
TYCKO, D. University of Columbia
WHITE, H. Lawrence Radiation Laboratory
ZOLL, A.J. University of Cambridge

and

CERN staff and visiting scientists.