



# RF system challenges for future $e^+e^-$ circular colliders

Olivier Brunner<sup>a</sup> , Erk Jensen<sup>b</sup>, Ivan Karpov<sup>c</sup>, Eric Montesinos<sup>d</sup>, Franck Peauger<sup>e</sup>, Igor Syrathev<sup>f</sup>

Accelerator Systems Department, CERN, 1211 Geneva, Geneva, Switzerland

Received: 21 October 2021 / Accepted: 25 November 2021

© The Author(s) 2021

**Abstract** The RF system is the centrepiece of any future circular lepton collider. In particular, the system is required to support the high intensity beams needed for pushing the luminosity at the lower energy regimes of future energy-frontier circular lepton colliders (e.g. for operation in the Z peak and at the WW threshold). Capturing, storing the beam and replacing energy losses from synchrotron radiation demand low frequency, low shunt resistance cavities, low number of cells and high RF power per cell. Controlling the beam both transversely and longitudinally requires sophisticated beam control and timing systems. Additional RF systems are used to ensure transverse stability (feedback systems) and to increase the luminosity (crab cavities). Operation at high energies (such as the ZH and  $t\bar{t}$  threshold) requires a very large accelerating voltage, since synchrotron radiation leads to significantly higher energy losses per turn which must be compensated. Since the RF system is to be optimised in size and energy efficiency for varying demands for the different operational modes, the spectrum of R&D challenges covers a wide range of technologies.

## 1 Introduction

The parameter range for any future circular collider is driven by the benefits to science. It turns out to be large and challenging for the radiofrequency (RF) system due to the voltage requirements and beam-loading conditions. The basic parameters of FCC-ee [1] are shown in Table 1.

## 2 Proposed parameters and their trade-offs

The RF voltage requirement expected for future circular colliders spans from 0.1 to more than 11 GV. At low energies, an Ampere-class machine can be considered to maximise the

<sup>a</sup> e-mail: [Olivier.Brunner@cern.ch](mailto:Olivier.Brunner@cern.ch) (corresponding author)

<sup>b</sup> e-mail: [Erk.Jensen@cern.ch](mailto:Erk.Jensen@cern.ch)

<sup>c</sup> e-mail: [Ivan.Karpov@cern.ch](mailto:Ivan.Karpov@cern.ch)

<sup>d</sup> e-mail: [Eric.Montesinos@cern.ch](mailto:Eric.Montesinos@cern.ch)

<sup>e</sup> e-mail: [Franck.Peauger@cern.ch](mailto:Franck.Peauger@cern.ch)

<sup>f</sup> e-mail: [Igor.Syrathev@cern.ch](mailto:Igor.Syrathev@cern.ch)

**Table 1** FCC-ee machine parameters

Parameter	Z	WW	ZH	$\bar{t}\bar{t}_1$	$\bar{t}\bar{t}_2$
Beam Energy [GeV]	45.6	80	120	175	182.5
Beam current [mA]	1390	147	29	6.4	5.4
Number of bunches	16640	2000	328	59	48
Beam RF voltage [MV]	100	750	2000	9500	10930
Run time [year]	4	2	3	1	4

luminosity, whereas high energies strongly constrain the beam current. A single RF system design to meet all cases is not efficient.

In a heavily beam loaded machine, the cavity shape must be optimised with respect to higher-order modes (HOM). This favours low frequency, low shunt impedance and a low number of cells per cavity. 400–600 MHz continuous wave (CW) RF systems are generally considered. Such frequencies are also the natural choice for high energy hadron machines such as LHC [2] or FCC-hh [3]. The chosen approach therefore provides the opportunity to reuse a large part of the hardware and infrastructure for a subsequent hadron collider.

An Ampere-class system is required for the Z peak and WW threshold regions, which, in addition to the HOM requirements mentioned above, need high RF power per cell, whereas the ZH and  $\bar{t}\bar{t}$  threshold operation points require high efficiency in delivery of power to the beam and multi-cell cavities to optimise the total size of the RF system. Operating at the  $\bar{t}\bar{t}$  threshold, for example, requires thousands of cavities. At the higher energies and lower beam currents, operating at higher frequencies is considered.

### 3 Longitudinal beam dynamics and RF feedback

Longitudinal instabilities driven by the cavity fundamental impedance are the main concern when running at the Z peak [4]. Their growth rate is much faster than the synchrotron radiation damping. Strong feedback around the cavities will therefore be required to maintain stability and to damp the coupled-bunch instabilities for high intensities [5]. A direct RF feedback can be supplemented by a one-turn delay feedback, giving extra impedance reduction. Bunch-by-bunch longitudinal feedback may also be required to suppress the strongest coupled-bunch modes.

A detailed analysis of the impact of the beam interaction with the fundamental impedance of the accelerating cavities on the bunch-by-bunch parameters (bunch length, synchronous phase, etc.) was performed for the Z peak machine using a steady-state time-domain approach [6]. For the regular filling schemes, the main contribution to phase and amplitude modulation of the cavity voltage comes from the abort gap. The resultant peak-to-peak value of bunch-by-bunch phase modulation exceeds 70 ps for abort gaps longer than 2  $\mu$ s. The results agree well with those of the frequency-domain method developed by Pedersen [7].

One of the ways to eliminate the shift of a collision point due to beam phase modulation is matching of abort gap transients. The direct RF feedback with the overall loop delay of 700 ns (similar to the LHC [8]) can also mitigate the transient beam loading at the cost of an additional power generator. For the example shown in Fig. 1, about a 5% increase of the generator power (the right plot) is sufficient to reduce the bunch-by-bunch phase modulation by 20% (the left plot).

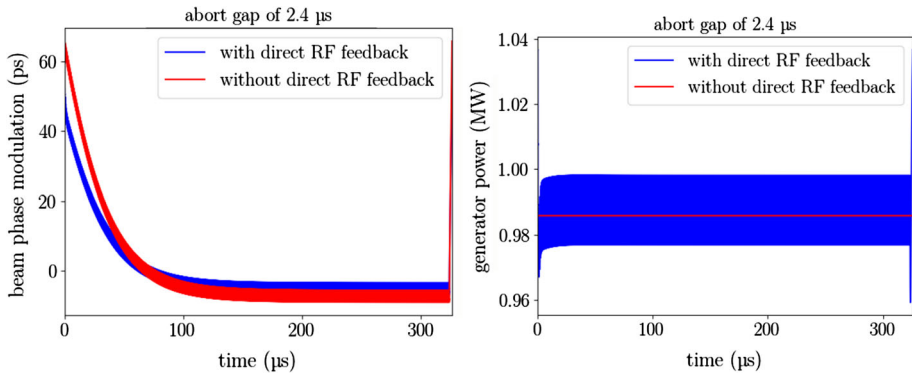

**Fig. 1** Variation of bunch-by-bunch phase with and without the direct RF feedback (left plot) and instantaneous generator power within one turn (right plot)

#### 4 Cavity design and scenarios for FCC

In order to identify the optimum cavity type for the FCC-ee parameter space, systematic studies of the alternative cavity topologies and technologies were performed, covering the known cavity types—elliptical cavity, half-wave resonator (HWR), quarter-wave resonator (QWR), spoke cavity and re-entrant cavity. Although none of these proved to be a perfect fit, the exercise has led to a promising new concept: the superconducting Slotted Waveguide Elliptical cavity (SWELL) [9]. The effectiveness of damping transverse higher-order modes (HOM) using slotted irises was first introduced and demonstrated for room-temperature copper cavities in the early nineties [10]. In this configuration, the accelerating cell is composed of independent sectors (e.g. four quadrants), separated by radial slots. This topology provides optimum damping of the transverse HOMs, thanks to the nature of their symmetries, together with minimal perturbation of the longitudinal accelerating mode. In the last couple of decades, several copper, normal-conducting, quadrant accelerating structure prototypes were developed and tested at CERN, SLAC and KEK, e.g. for the CLIC project [11, 12]. For example, the 3 GHz TW accelerating structure with slotted irises and constant aperture (SICA) [13] was developed at CERN and successfully used in the drive beam electron accelerator of CERN's CTF3, with a nominal beam current of 4 A. Another successful application of this technology is the CLIC Power Extraction and Transfer Structure (PETS), where very strong HOM damping was achieved using eight sectors (octants) [14].

Transferring the slotted irises concept to superconducting RF (SRF) cavities for high current (Ampere-class) machines, such as FCC-ee at the Z peak, is very tempting as it could allow cavities with better acceleration efficiency to be used. In 2010, a low impedance 1.3 GHz SRF multi-cell cavity, equipped with three slotted damping waveguides, was studied and built for the high current ERL [15]. The high external  $Q$  factor operating mode ( $> 1 \times 10^{10}$ ) and the strong damping of transverse HOMs were confirmed in CST/3D [16] computer simulations. A three-cell cavity based on this design was built from Nb sheets and tested [17]. The accelerating gradient reached 2.4 MV/m at 4.2 K with a  $Q_0$  of  $1.4 \times 10^8$ , limited by the input power.

Systematic RF simulations, including thorough eigenmode and wakefield calculations, were done in order to refine the parameter set for an optimised SWELL cavity for FCC-ee. The cavity performance was evaluated for cell numbers ranging from 1 to 4, operating frequencies between 400 and 800 MHz, and from 4 to 8 slots. Particular attention was paid to

**Fig. 2** Cut-away view of the 2-cell, 4-slot SWELL Cavity

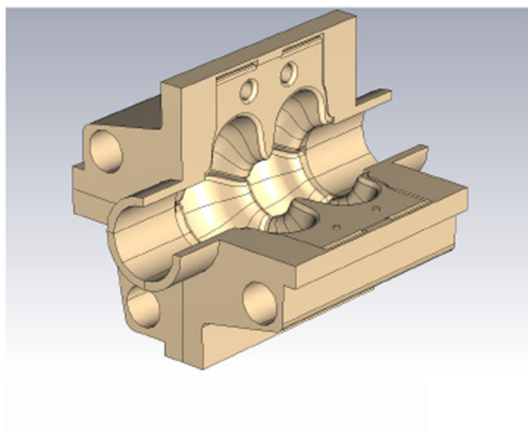

**Table 2** Parameters of the 2-cell, 4-slot SWELL cavity

Parameter	Z	WW	ZH	$\bar{t}$
Energy [J]	2	12.3	87.8	137.2
$E_{\text{surf, max}}$ [MV/m]	5.93	14.7	39.3	49.2
$B_{\text{surf, max}}$ [mT]	12.5	31	82.8	103
Accelerating gradient [MV/m]	2.4	6.0	16.0	16.0

the longitudinal and transverse beam impedances of dangerous higher-order modes near the threshold limits of multi-bunch instabilities. The high power RF requirements were evaluated for the five operating regimes of FCC-ee: Z, W, H,  $t_2$  and Z at reduced current, as the latter may be used for energy calibration.

While the technology for elliptical cavities has matured over decades, a suitable fabrication method still needs to be optimised for the SWELL cavity with its non-conventional geometry, and it remains to be demonstrated that it is compatible with industrial fabrication. Tolerances must be fully evaluated, it must be demonstrated that the longitudinal slot does not perturb the accelerating mode and possible failure modes must be investigated and evaluated in detail. However, it is clear that the fabrication by sectors, notably quadrants, also opens up its potential to completely new, possibly more efficient fabrication methods and good accessibility for surface treatments. Full experimental validation of the SWELL cavity is in full swing and at the centre of present cavity R&D.

The most recent RF design proposed for the 2-cell SWELL cavity includes a compact configuration of the slot ends, which limits the overall block dimensions to 400 mm width and 1 m length, as illustrated in Fig. 2. Thanks to a new cavity shape approach, the electrical and magnetic surface fields have been lowered compared to the previous design. Table 2 presents the parameters of the 2-cell 4-slot SWELL cavity.

The 2-cell, 4-slot SWELL cavity, operating in the range of 600–650 MHz, turns out to be a very favourable compromise and a good candidate to cover all FCC-ee machines. At lower frequencies, the cavity size becomes inappropriate, whilst at higher frequencies the cavity-beam interactions are difficult to manage.

The cavity installation sequence scenario proposed is as follows:

- Install 83 cavities per beam for the Z energy at nominal beam current of 1.39 A. The RF power has an optimum loaded quality factor of  $Q_L = 2 \times 10^4$ , and each cavity requires a minimum CW RF power of 600 kW. At this beam energy the cavity operating voltage is low (1.2 MV), corresponding to an accelerating gradient of 2.4 MV/m. The optimal detuning value of 62.6 kHz is several times the beam revolution frequency. Both the CW power and the detuning are challenging, but are considered to be achievable. It is estimated that there will be about 6.6 kW of HOM power per cavity at nominal beam current. For comparison, a level of 4 kW was expected for the baseline 400 MHz single cell cavity equipped with four-hook type HOM couplers.
- Install 167 additional cavities per beam for the WW and ZH energies (for 250 cavities per beam), to operate at accelerating voltages of 3 MV and 8 MV respectively (i.e.  $E_{\text{acc}}$  between 6 MV/m and 16 MV/m). A common loaded quality factor of  $Q_L = 6.5 \times 10^5$  is necessary, and the CW RF power level is only about 300 kW per cavity. Each of the existing 600 kW RF power sources can now feed two cavities. Operating this RF system at the Z peak energy is possible with a drastic reduction of beam current—250 mA should be considered as an upper limit, until the detailed analysis of the cavity-beam interaction is completed and taken into account.
- The  $\text{t}\bar{\text{t}}$  machine requires doubling the number of cavities and their re-alignment as proposed in [1] allows each cavity to accelerate both beams. It is important to note that at this stage of the study, all of the beam coupling impedance configurations, which are highly important for beam stability, have not been studied in detail.

## 5 SRF and cavity technology

### 5.1 High efficiency cavities

Energy efficiency and controlled electrical energy consumption are key factors for the sustainable operation of both the lepton and hadron colliders. Electron-positron colliders are particularly energy-hungry. For the past five decades, bulk niobium has been the material of choice for SRF cavities. In recent years, RF cavity performance has approached the theoretical limit for this superconductor, cavities made from Nb have become a de facto standard and have become mature. The amount of Nb required per cavity and the fabrication cost have become technical limitations for bulk-Nb cavities. The focus of a recently restarted R&D effort is towards finding competitive alternatives to bulk niobium that can deliver high acceleration gradients, a high quality factor up to high acceleration gradients and at low cost. Another aspect is the need to operate bulk-Nb cavity at a temperature of 2 K or below, which would require high cryogenic power—whilst operation at 4.5 K instead of 1.8 K requires a factor 4 less power for cryogenics.

Nb thin film on Cu substrate and  $\text{Nb}_3\text{Sn}$  alloy have the potential to outperform bulk Nb technology, and the objective is to develop these for cavity production. For this purpose, accelerator-quality 400 MHz and 800 MHz cavities, based on superconducting thin films on copper, have to be designed, built and optimised under realistic operating conditions. The main operating target is to significantly lower the cryogenic power consumption at RF fields comparable to those used in the LHC and to achieve break-even performance with bulk Nb cavities at 800 MHz.

## 5.2 Cavity technology

The copper substrates are prone to defects, in particular in the regions close to electron beam welds, and any progress on substrate manufacturing and preparation will have an immediate impact on the final RF performance. This was demonstrated by the seamless cavities produced for the HIE-ISOLDE project, where the  $Q$  slope was substantially reduced compared to their welded counterparts [18]. More recently, an R&D programme was launched at CERN to confirm this idea on 1.3 GHz elliptical cavities entirely machined out of a bulk copper billet. These cavities also benefited from newly developed copper electro-polishing techniques and optimised Nb sputtering methods [19,20]. Very promising results were obtained, and for the first time ever, the performance of thin film was comparable with the best state-of-the-art bulk Nb cavities.

At lower frequencies, bulk fabrication is not adapted for elliptical cavities and alternative fabrication techniques, in particular electro-hydroforming (EHF), are being developed to overcome the presence of welds in critical areas and minimise the presence of surface defects [21].

The four-quadrant concept of the SWELL cavity, however, is perfectly adapted to bulk machining, and allows, in addition, for easier coating, surface preparation and inspection.

## 5.3 Beyond niobium

The A15 compounds have the potential to outperform niobium as their BCS surface resistance is much lower due to the higher critical temperatures. Nb<sub>3</sub>Sn cavities obtained by thermal diffusion of Sn in bulk Nb have a performance at 4.5 K which is similar to state-of-the-art bulk Nb cavities at 2 K. A programme aimed at the synthesis of Nb<sub>3</sub>Sn films on copper substrates is ongoing at CERN and has already produced high-quality films on small samples [22,23].

The brittleness of Nb<sub>3</sub>Sn is well known; it makes correct tuning of the cavity more difficult, since the elastic deformation typically applied to bulk Nb cavities is excluded. An interesting approach to tuning in this case is the use of so-called Fast Reactive Tuners (FRT), which are strongly coupled, external, variable reactances. They are very interesting also for use with conventional SRF cavities since they can act very fast (ns) and thus allow the compensation of microphonics. Recent developments and tests with prototypes show very promising results; these use piezoelectric material referred to as BST (BaTiO<sub>3</sub>-SrTiO<sub>3</sub>), the  $\epsilon$  of which can be modified very rapidly by applying a bias voltage. The suitability and longevity of these novel FRTs with full SRF systems without and with beam must still be demonstrated.

Interesting results, on samples, have been obtained on SIS (superconducting–insulating–superconducting) multilayers [24,25]. The principle is to screen the Nb cavity (bulk or thin film) with a thin layer of high  $T_c$  material to avoid vortex penetration. The parameters and materials of the different layers are of course critical and need further R&D but enhancement of both critical fields and  $T_c$  was recently demonstrated.

# 6 Fundamental power couplers

## 6.1 RF power couplers

In order to achieve the proposed configurations at the Z peak and at the W pair threshold, the RF coupler technology must also be developed to increase their CW power transfer capability; the HOM couplers will have to deal with high beam loading and must extract

**Fig. 3** Schematic of the LHC power coupler serving as model for a FCC-ee power coupler design

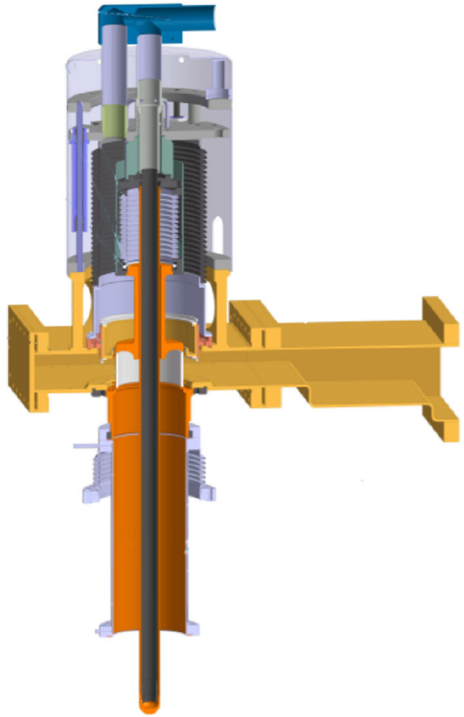

kilowatts of RF power. Progress with the fundamental power couplers will be essential to limit the cost and size of the RF system. The target value for fixed couplers is 1 MW CW per power coupler at 400 MHz [26]. The design of the fixed power couplers must ensure that their coupling coefficient can easily be changed for the different machines, as imposed by the varying machine parameters and overall time line. In particular, the external  $Q$  of the coupler must be adaptable ‘in situ’, without venting the cavities.

Fundamental power couplers for superconducting cavities are among the most important and most complex auxiliary systems. They must simultaneously deliver RF power to the beam and separate the cavity ultra-high vacuum, ultra-low temperature environment from air-filled, room-temperature transmission lines, as illustrated in Fig. 3.

## 7 High Efficiency Radiofrequency Power Sources

### 7.1 High efficiency klystron development for FCC

The need to provide two times 50 MW of continuous RF power sets the overall scale of the system. Improving energy efficiency and reducing energy demand is crucial for such a particle collider. Therefore, highly efficient RF power sources need to be conceived [27].

The High Efficiency International Klystron Activity (HEIKA) [28] was initiated at CERN in 2014 to evaluate and develop new bunching technologies for high efficiency klystrons [29]. Design calculations predict efficiency that increases ranging from 65% to potentially above 80%, resulting in significantly lower operation cost and reduced needs for the cooling

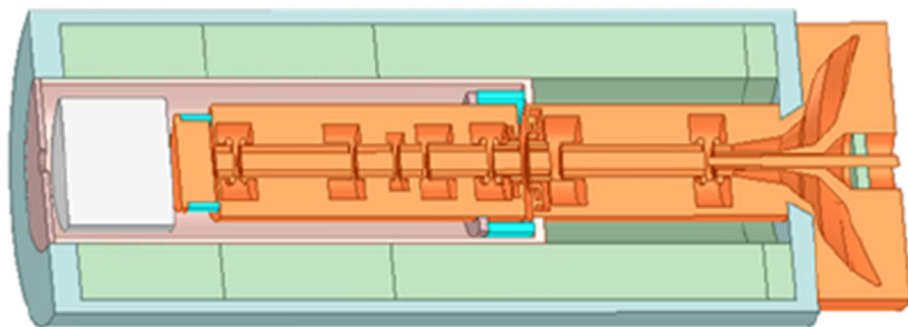

**Fig. 4** Artist's view of the Two-Stage MBK for FCC-ee

**Table 3** Two-Stage FCC MBK design and CST 3D PIC simulations

Parameters	Design	CST 3D PIC
Frequency	400 MHz	400 MHz
Total voltage	58 kV	58 kV
First stage voltage	10 kV–20 kV	11.5 kV
Number of beams	10	10
Total current	27 A	27 A
Output power	> 1.2 MW	1.28 MW
Efficiency	80%	79%
RF circuit length	< 2 m	1.6 m

capacity. One critical step towards the realisation of these devices is the development and use of a software called KlyC [30] to optimise system designs with high accuracy and short iteration times.

In the current FCC-ee baseline layout, the most challenging requirements are attributed to the 400 MHz, 1.2 MW, CW klystron needed for the Z peak operation. Apart from the high efficiency, it is very advisable to have a compact tube in its vertical configuration, which can operate at a relatively low voltage ( $< 60$  kV) to avoid the need to use insulating oil in the tunnel. The recently developed Two-Stage (TS) klystron technology [31] combined with conventional Multi-Beam Klystron (MBK) approach allows these demands to be fulfilled. An artists view of the TS FCC MBK is shown in Fig. 4. The tube design is still in progress; 3D Particle-In-Cell (PIC) simulations, however, confirmed the expected tube performance, see Table 3.

## 8 Summary and prospects

FCC-ee sets new challenges for RF system design and the associated R&D, since it requires, on the one hand, an Ampere-class machine at low energy (Z peak), whilst, on the other hand, requiring large voltages to operate at high energy ( $\bar{t}\bar{t}$ ). Initially seemed it impossible to cover these requirements with a single RF system concept. Careful beam dynamics studies and new concepts in SRF cavities now seem to allow such a cost-effective approach.



The SWELL cavity promises a good response to both effective damping of higher-order modes to suppress beam instabilities and provision of high accelerating gradient at low cryogenic loss. The same cavity can be used for all five operating regimes of FCC-ee (including calibration runs at the Z-pole in the high energy machine configurations). The proposed installation scenario features staged installation of cavities and a rather elegant reuse of the high power RF stations for the different flavours of the machine (Z, WW, ZH,  $t\bar{t}$ ). The RF system evolution towards the higher energy machines leaves the door open for 'simplified' SWELL cavities (i.e. without the HOM extraction system) and to standard multi-cell, high gradient elliptical cavities.

The key feature of the SWELL cavity is its topology in sectors (quadrants) with damping slots between them, which brings several advantages: it allows heavy HOM damping, it opens the possibility of modern fabrication methods, it possibly avoids welded joints in the high magnetic field area, it eases the Nb coating of the machined copper quadrants, and it possibly does not require a helium vessel.

Another area of R&D towards better, more cost-effective cavities is the possible use of Nb<sub>3</sub>Sn or similar so-called A15 materials with higher  $T_c$ , which would be operated at higher temperature and thus make significant savings in investment and operation cost of the cryogenic system with otherwise similar, or even better, performance parameters. Tuning of the cavities using this brittle material can possibly be reached with BST-based 'Fast Reactive Tuners (FRT)'.

For an accelerator with the need of  $\mathcal{O}(100\text{ MW})$  in CW during operation, it is clear that the RF power couplers are of extreme importance. To allow operation at different energies the coupling must remain 'adaptable' to the optimum  $Q_{\text{ext}}$ . An improved design of the FPC is still required to alleviate slot modes and mode coupling.

Various concepts for RF power sources with high energy efficiency have been studied in view of the needs of FCC-ee. The encouraging findings of initial investigations of the High Efficiency International Klystron Activity (HEIKA) collaboration have recently resulted in the industrial manufacture of high-efficiency tubes for LHC, CLIC and other projects. The R&D has culminated in the invention of the two-stage MBK, which would not only allow high efficiency but also the reduction of the supply voltage. This approach would no longer require oil insulation, thereby avoiding a significant underground safety hazard.

## 8.1 Prospects for cost savings

About 2600 cells are required to produce a total RF voltage of 11 GV at the highest energy point. The small number of bunches and the low beam loading suggest the possibility of a common RF system for both beams, with a slightly modified layout in the RF straight sections. This common RF system can be accomplished by re-aligning the already installed cavities (which earlier, in the Higgs production mode, are used for either one or the other beam) on a common beam axis and by installing additional cavities to achieve an additional voltage of 7 GV. For this second part, the relatively modest CW RF power per cavity at this operation point enables the deployment of 800 MHz bulk-Nb five-cell cavities. A first prototype cavity shows excellent performance, with an unloaded  $Q$  value about two times the target value [32]. Although these cavities must be operated at 2 K, they provide a better acceleration efficiency and result in a significantly reduced overall footprint and, hence, in

potentially significant cost savings. Higher frequencies have been excluded due to transverse impedance considerations and power coupler limitations for CW operation.

**Funding** Open access funding provided by CERN (European Organization for Nuclear Research)

**Open Access** This article is licensed under a Creative Commons Attribution 4.0 International License, which permits use, sharing, adaptation, distribution and reproduction in any medium or format, as long as you give appropriate credit to the original author(s) and the source, provide a link to the Creative Commons licence, and indicate if changes were made. The images or other third party material in this article are included in the article's Creative Commons licence, unless indicated otherwise in a credit line to the material. If material is not included in the article's Creative Commons licence and your intended use is not permitted by statutory regulation or exceeds the permitted use, you will need to obtain permission directly from the copyright holder. To view a copy of this licence, visit <http://creativecommons.org/licenses/by/4.0/>.

## References

1. A. Abada, M. Abbrescia, S. Abdus Salam et al., FCC-ee: The Lepton Collider. *Eur. Phys. J. Spec. Top.* **228**, 261–623 (2019). <https://doi.org/10.1140/epjst/e2019-900045-4>
2. O.S. Brüning, P. Collier, P. Lebrun, S. Myers, R. Ostojic, J. Poole, P. Proudlock, *LHC Design Report*. CERN Yellow Reports: Monographs (CERN, Geneva, 2004). <https://doi.org/10.5170/CERN-2004-003-V-1>
3. A. Abada, M. Abbrescia, S. Abdus Salam et al., FCC-hh: The Hadron Collider: Future Circular Collider Conceptual Design Report Volume 3. Future Circular Collider. Tech. rep., CERN, Geneva (2018). <https://doi.org/10.1140/epjst/e2019-900087-0>
4. J. Fox, T. Mastorides, C. Rivetta, D. Van Winkle, D. Teytelman, Lessons learned from positron-electron project low level RF and longitudinal feedback. *Phys. Rev. ST Accel. Beams* **13**, 052–802 (2010). <https://doi.org/10.1103/PhysRevSTAB.13.052802>
5. P. Baudrenghien, LLRF Lessons learned LHC and PEP-II relevance to FCC hh/ee (2016). Second Annual Meeting of the Future Circular Collider study, Rome, Italy (2016)
6. I. Karpov, P. Baudrenghien, in *Proc. 61st ICFA Advanced Beam Dynamics Workshop (HB'18), Daejeon, Korea, 17–22 June 2018* (2018), no. 61 in ICFA Advanced Beam Dynamics Workshop, pp. 266–271. 10.18429/JACoW-HB2018-WEP2P0003
7. F. Pedersen, Beam loading effects in the CERN PS booster. *IEEE Trans. Nucl. Sci.* **22**(3), 1906–1909 (1985)
8. P. Baudrenghien, T. Mastoridis, Fundamental cavity impedance and longitudinal coupled-bunch instabilities at the high luminosity large hadron collider. *Phys. Rev. Accel. Beams* **20**, 011,004 (2017). <https://doi.org/10.1103/PhysRevAccelBeams.20.011004>
9. I. Syratchev, F. Peauger, I. Karpov, O. Brunner, A Superconducting Slotted Waveguide Elliptical Cavity for FCC-ee (2021). <https://doi.org/10.5281/zenodo.5031953>
10. H. Deruyter, et al., in *Proc. Linear Accelerator Conference (LINAC'90), September 1990, Albuquerque, New Mexico, USA*, pp. 132–134 (1990). <https://jacow.org/190/papers/MO432.pdf>
11. T. Higo et al., in *Proc. European Particle Accelerator Conference (EPAC08), June 2008, Genoa, Italy*, pp. 2716–2718 (2008). <https://jacow.org/e08/papers/WEP084.pdf>
12. J. Wang et al., in *Proc. 1st International Particle Accelerator Conference (IPAC'10), May 2010, Kyoto, Japan*, pp. 3819–3821 (2010). <https://jacow.org/IPAC10/papers/THPEA064.pdf>
13. E. Jensen, in *Proc Linear Accelerator Conference (LINAC'02), August 2002, Gyeongju, Korea*, pp. 34–36 (2002). <https://jacow.org/102/PAPERS/MO401.PDF>
14. I. Syratchev, et al., in *Proc. 2007 Particle Accelerator Conference (PAC'07), June 2007, Albuquerque, New Mexico, USA*, pp. 2194–2196 (2007). <https://jacow.org/pac07/papers/WEPMN071.pdf>
15. Z. Liu, A. Nassiri, Novel superconducting RF structure for ampere-class beam current for multi-GeV energy recovery linacs. *Phys. Rev. ST Accel. Beams* **13**, 012,001 (2010). <https://doi.org/10.1103/PhysRevSTAB.13.012001>
16. CST Studio Suite. Available from Dassault Systemes. <https://www.3ds.com/products-services/simulia/products/cst-studio-suite/>
17. Z. Liu et al., in *Proc. of International Conference on RF Superconductivity (SRF'17), Lanzhou, China, July 17–21, 2017*, pp. 451–453 (2018). <https://doi.org/10.18429/JACoW-SRF2017-TUPB033>

18. W.V. Delsolaro, Thin film research: CERN experience and possible future applications (2018). <https://agenda.infn.it/contributionDisplay.py?sessionId=12&contribId=4&confId=13791>. TESLA Technology Collaboration (TTC) Meeting, Milano, Italy
19. G. Rossaz, Superconducting thin films studies at CERN. Fifth Annual Meeting of the Future Circular Collider study, CERN (2021). <https://indico.cern.ch/event/995850/contributions/4411832/contribution.pdf>
20. L. Vega Cid, in *International Conference on RF superconductivity (SRF'21), virtual conference, June 2021* (2021). [https://indico.frib.msu.edu/event/38/attachments/158/1275/TUPTEV009\\_rev\\_3.pdf](https://indico.frib.msu.edu/event/38/attachments/158/1275/TUPTEV009_rev_3.pdf)
21. M. Garlasche, Hydroforming elliptical SRF cavities: Studies on 1.3 GHz and beyond. Fifth Annual Meeting of the Future Circular Collider study, CERN (2021). <https://indico.cern.ch/event/995850/contributions/4409269/attachments/2273368/3861363/Hydroforming%20Ellipt%20SRF%20Cavities%201.3%20GHz%20Beyond%20Final.pdf>
22. S. Posen, D.L. Hall, Nb<sub>3</sub>Sn superconducting radiofrequency cavities: fabrication, results, properties, and prospects. *Superconductor Science and Technology* (2017)
23. K. Ilyina-Brunner, Magnetron Sputtering of Nb<sub>3</sub>Sn thin films on copper for SRF application (2018). Fourth Annual Meeting of the Future Circular Collider study, Amsterdam, The Netherlands (2018)
24. M. Garlasche, Overview of multilayer developments at Jlab. Fifth Annual Meeting of the Future Circular Collider study, CERN (2021). <https://indico.cern.ch/event/995850/contributions/4416532/attachments/2274614/3863777/MLdvlpmt-JLab-FCC2021.pdf>
25. M. Garlasche, SRF characterization of multilayers. Fifth Annual Meeting of the Future Circular Collider study, CERN (2021). <https://indico.cern.ch/event/995850/contributions/4397973/attachments/2274618/3863781/2021-07-01%20FCC%20week%20Keckert.pdf>
26. E. Montesinos, FPC challenges and perspectives for FCC. Third Annual Meeting of the Future Circular Collider study, Berlin, Germany, 2017, CERN (2017). [https://indico.cern.ch/event/556692/contributions/2484366/attachments/1466409/2269379/20170530\\_FCC\\_week\\_FPC.pdf](https://indico.cern.ch/event/556692/contributions/2484366/attachments/1466409/2269379/20170530_FCC_week_FPC.pdf)
27. E. Jensen, Energy Efficiency of HEP Infrastructures. CERN Council Open Symposium on the Update of European Strategy for Particle Physics (2019). <https://indico.cern.ch/event/808335/contributions/3365146>
28. I. Syratchev, Introduction to HEIKA. Tentative structure and objectives. CLIC Workshop 2015, CERN, Geneva, Switzerland, CERN (2015). <https://indico.cern.ch/event/336335/contributions/789041/>
29. C. Marrelli, I. Syratchev, A. Yu, Toward High-Power Klystrons With RF Power Conversion Efficiency on the Order of 90%. *IEEE Trans. Electron. Devices* **62**(10), 3406 (2015)
30. J. Cai, I. Syratchev, KlyC: Large Signal Simulation Code for Klystrons (2017). Submitted to IEEE TED, January 2016
31. I. Syratchev, Two Stage High Efficiency Klystron for FCC-ee. Fcc week, 2021, CERN (2021). <https://indico.cern.ch/event/995850/contributions/4400122/>
32. P. Charitos, F. Marhauser, The first 802 MHz prototype cavities for CERN's future circular collider. *Accelerating News* **25**, (2018). <https://fcc.web.cern.ch/Pages/news/The-first-802-MHz-prototype-cavities-for-a-future-circular-collider.aspx>