

CERN NEUTRINO CRYOGENIC CONTROL SYSTEM TECHNOLOGY: FROM THE WA105 TEST FACILITY TO THE NP04 AND NP02 PLATFORMS

Roberto Orlandi, Czeslaw Fluder and Marco Pezzetti
 CERN, CH-1211 Genève 23, Switzerland

Abstract

The CERN Neutrino Platform is CERN’s undertaking to foster fundamental research in neutrino physics at particle accelerators worldwide. Different projects were undertaken and realized at CERN for this purpose. First of this series is the 35 tons liquid argon cryostat based test facility named WA105, succeeded by the 800 tons liquid argon each, designated as NP04 and NP02. The cryogenic control system of these experiments was entirely designed and constructed by CERN to operate 365 days a year in a safe way through all the different phases aimed to cool down and fill the cryostat until reaching nominal stable conditions. This paper describes the process control system design methodology, the off line validation and the operational commissioning including fault scenario handling. A systematic usage of advanced informatics tools, such as CERN/UNICOS tools, Git[1] and Jenkins[2], used to ensure a smooth and systematic software development of the process, is presented. Finally, particular attention is given to the adoption of the CERN cryogenic technical standard solutions to enhance reliability, safety and flexibility of the system working 24 hours at day.

INTRODUCTION

WA105, NP02, and NP04 are three different experiments belonging to the Neutrino Platform. WA105 and NP04 have been already commissioned during the last two years, while NP02 has been operational since June 2019.

The cryogenic process of these experiments is supported by a control system entirely designed and developed at CERN to drive the cryogenic components through the different phases of the process.

The development of such system relies on an efficient and tested methodology to build a control infrastructure that respects the initial needs of the process, as much as it allows to integrate at any moment new requirements, coming from the process evolution. This is possible thanks to the technologies that will be described in the next chapters of this paper and to a balanced computation of software and hardware spare objects in the phase of design.

The building of the control system starts from three main inputs:

- Piping and Instrumentation Diagram (P&ID): graphical representation of the full cryogenic system, showing all the objects and their connections
- Part list: detailed description of all the objects. It specifies characteristics such as the range or the type of the electrical connections

- Process logic specifications: describes the entire process and the logic to be implemented by each object

Based on these inputs, process and electrical analysis are performed to gather all the information needed to build the electrical infrastructure and the software systems that include PLC and SCADA development, as shown in Fig. 1.

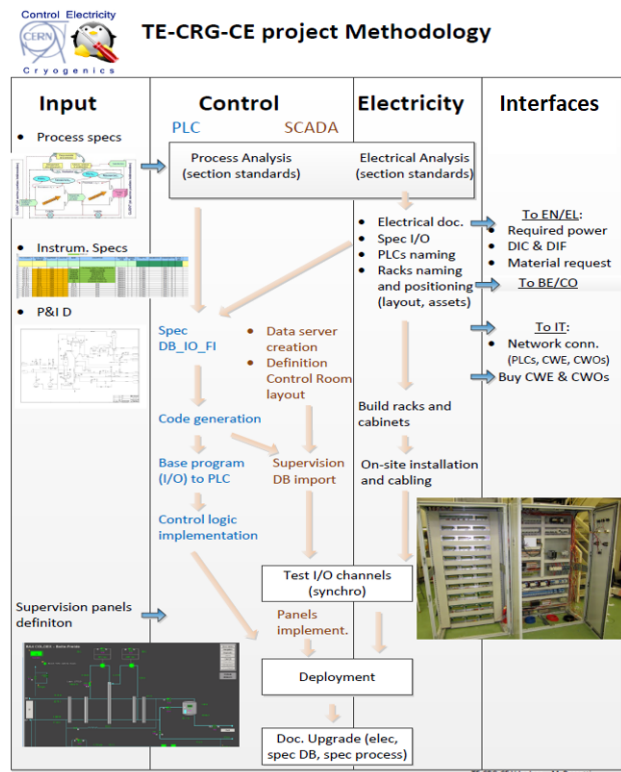

Figure 1: Cryogenics controls methodology.

CHALLENGES AND DEVELOPMENT TECHNOLOGIES

While WA105 was operational for few months, NP02 and NP04 will have a lifetime of eight years, during which the cryogenic process shall keep the cryostat in steady-state with 800 tons of liquid argon. During this time, the control system shall ensure operability, protection, maintainability, and availability 24 hours a day, 365 days a year.

Based on the LHC cryogenic system operational experience [3] and on the availability studies including root failures causes global analysis, made on other cryogenic plants at CERN, such as the LHC Atlas argon and NA62 Krypton calorimeters [4], the control architecture was designed to

Content from this work may be used under the terms of the CC BY 3.0 licence (© 2019). Any distribution of this work must maintain attribution to the author(s), title of the work, publisher, and DOI.

improve system availability, reduce the number of components, optimize maintenance and improve flexibility during operation[5].

Cabinet Independence

NP02 and NP04 experiences rely respectively on eight and nine control cabinets, each one responsible for different areas of the cryogenic instrumentation (see Fig. 2). In this way, when a single cabinet experiences a failure or requires maintenance, the process keeps running in degraded mode until the failing cabinet will be again operational. Two electrical racks are used to supply 24V power and also contain TPG controllers for the vacuum measurements.

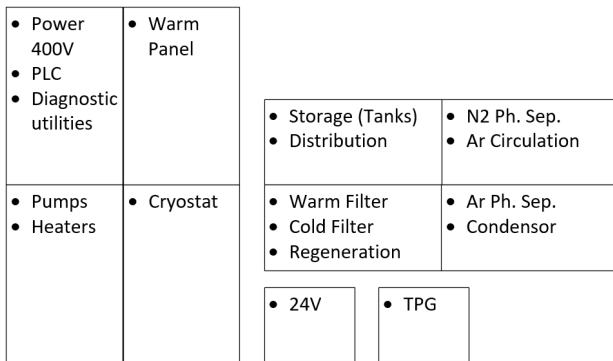

Figure 2: NP02 cabinets: each one is dedicated to a different area of the cryogenic installation.

Electrical Redundancy

Critical instrumentation such as PLCs, I/O modules, TPG controllers, and liquid pumps are supplied by redundant power sources. In fact, in case of a cut of the normal power, the availability of the control system is guaranteed by the usage of UPS batteries.

Ethernet

PLCs rely on Ethernet connection to communicate between them and with the data-server where the SCADA is running. Redundant power distribution supplies the router that provides this Ethernet connection to guarantee service availability during a power cut.

CERN CPC UNICOS

The control system software is developed using the Unified Industrial Control System (UNICOS) and its Continuous Process Control package (UCPC)[6]. This framework, developed at CERN, provides a library of standard device types and a set of tools to design and implement industrial control applications[7]. Three main phases compose the development process: generation, which is done by the UNICOS Application Builder (UAB), importation of the generated files in the programming software (Siemens Simatic S7©), and compilation, which builds the project. This can be then deployed in a test environment, which only partially imitates the production system since PLCs are not connected

to any real hardware, such as sensors or actuators. After passing the test, the system is ready to be released into production. The guarantee of the support of the CERN UNICOS developers and the standard way of developing software, improve the maintenance of the project during the years.

Interlocks

Interlock alarms protect the system from reaching abnormal situations. In fact, it is possible to define certain conditions (e.g., high/low pressure, high/low temperature) where the single objects (e.g., valves or motors) or even a specific group of objects will move to their safe position. In this way, the instrumentation is driven safely in front of potentially dangerous situations.

Automatic Calls

Specific alarms automatically trig phone calls and SMS to the operators, so that they can be warned in case something unexpected happened that could need human intervention.

Process Automatization with Jenkins

Generation, importation, and compilation are substantial time-consuming tasks that require continuous manual interaction of the developer. Due to this reason, a way to integrate all the tasks of the development process into a Continuous Integration (CI) system is managed in the cryogenic group using Jenkins[8]. In fact, after proper setup and configuration, this system completely frees developers from executing these tasks manually. The jobs configured in the CI system implement in the same sequence the same development process phases previously described (generation importation, and compilation), taking as input specification files stored in a GIT repository, and providing as an artifact the compiled project ready to be loaded in the PLC. This system allows developers to save time spent in repetitive operations and gives the possibility to start the chain of tasks after any modification, being able to rely on a last successful artifact at any moment. This increases the availability and the maintainability of the system consistently.

Repository

CERN uses a version control software that automatically backs-up, compares, and handles different versions of control projects. It allows to store and check out the last version of the program keeping track of the modifications and the user who did it, as much as to check differences between the stored versions and the current PLC's implementation.

DIP Protocol

Cryogenic process relies on some values read by the detector system such as the temperature and the argon level of the cryostat. Due to the fact that the two systems have different groundings and they are connected to different networks, a not ordinary solution for cryogenic control systems that require high availability and fault resistant solutions was designed and implemented to allow such exchange of values.

This solution takes advantage of the Data Interchange Protocol (DIP), a publish-subscribe middleware infrastructure developed at CERN to allow lightweight communications between distinct industrial control systems [9] and to allow monitoring of values without giving the opportunity to use them in the control process.

The creation of a DIP client at WinCC OA [10] level and the usage of a script designed and implemented for this purpose, made possible to observe the values published on the DIP server by the detector system and store them in the PLC, as Analog Parameters that are UNICOS objects that work as interface between the SCADA and the PLC (see Fig. 3). Detector system publishes as well a counter to ensure the working communication. Cryogenic control system will trigger automatic phone call to the operators otherwise.

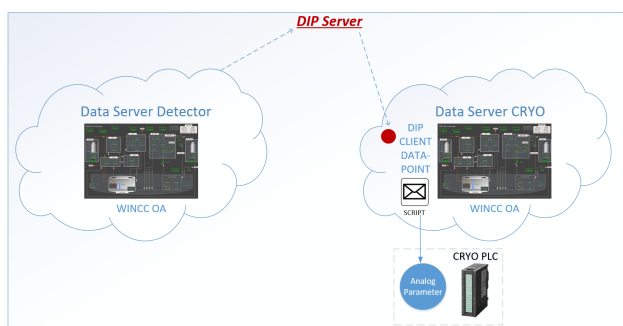

Figure 3: Detector-Cryogenic systems communication solution.

CRYOGENIC CONTROL SYSTEM

Electrical & Process Analysis

Based on the P&ID and the "Part list", an analysis of the requirements has been performed to define the software and hardware control system architecture to ensure the characteristics previously described. Part of this analysis aims to understand the type of instrumentation to connect to the PLC and to define the electrical equipment needed in the cabinets, as well as the necessary amount of I/O modules to be installed. Once this information is gathered, it is possible to start the production of the electrical diagrams and the construction of the electrical installation. At the same time, from the "Process logic specifications", it is possible to analyze the cryogenic process, and to define the PLC program structure in terms of Process Control Objects (PCOs), that are UNICOS objects that drive a set of objects (see Fig. 4).

The definition of the desired program structure and the "Process logic specifications" lead to the creation of a simplified version of the P&ID where it is possible to verify the status of each object belonging to the control system in each different phase of the process (e.g., see Fig. 5). In fact, in the three projects, the cryogenic system goes through the following steps: default mode, purge open-loop, purge closed-loop, cool-down, filling, steady-state, and emptying.

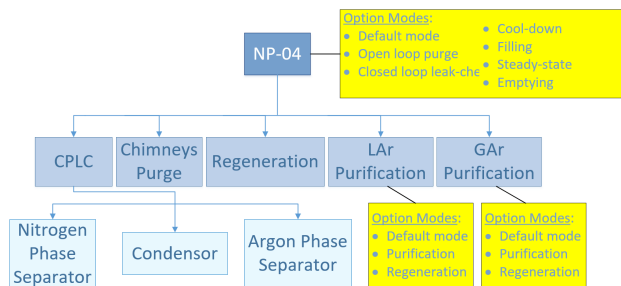

Figure 4: Portion of the NP04 PLC breakdown structure.

This document contains the status of each object belonging to the control system at each phase of the process.

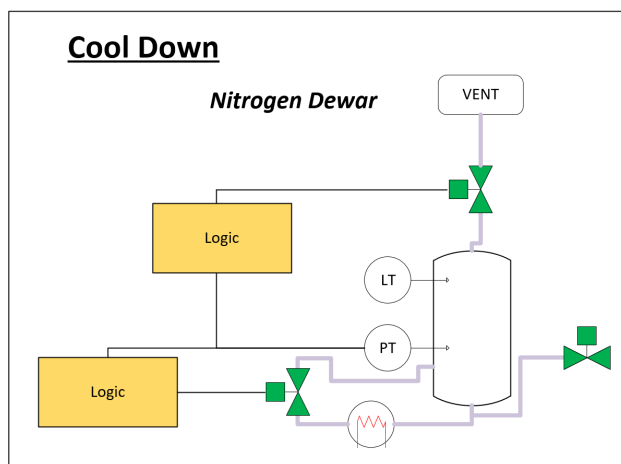

Figure 5: WA105 - LN2 Tank Pressurization simplification.

Architecture

WA105 It was the first, in terms of time, of the three experiments to be commissioned. Based on this experience, improvement to the control system approach were made in the development of NP02 and NP04. The WA105's structure differs from NP02 and NP04 because of the used approach and also in terms of I/O quantity. Based on an electrical installation composed by four racks, a Siemens 317 PLC controls all the inputs and outputs through 9AI, 2AO, 6DI, 3DO modules (8 channels for each analog one, 32 for each digital card), and the usage of 4 Profibus distributors to control the SIPART instrumentation with Profibus PA connections.

NP02 and NP04 The control system for the NP02 and NP04 facility aims to be as much as possible coherent with its instrumentation design. Analyzing the P&ID representing the cryogenic instrumentation of the experiment, a decomposition in three main areas can be made. First one is used for storage and distribution of argon and nitrogen, shared for both experiments; while the other two are dedicated to NP02 and NP04. Each one of these areas then is composed of cryogenic instrumentation such as valves, sensors, and motors mostly grouped in valve boxes.

Content from this work may be used under the terms of the CC BY 3.0 licence (© 2019). Any distribution of this work must maintain attribution to the author(s), title of the work, publisher, and DOI.

The control system design follows this structure in its hardware architecture. Each one of these areas, in fact, is controlled by dedicated PLCs, I/O modules, cabinets, and field boxes (see Fig. 6 and Fig. 2).

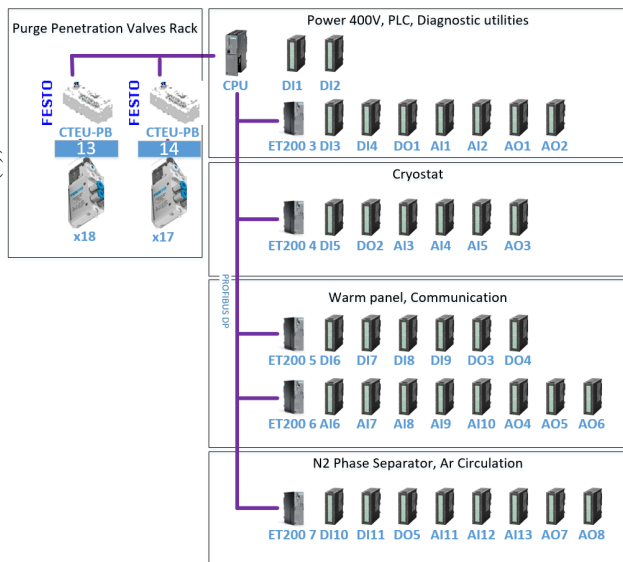

Figure 6: Portion of the NP02 PLC Architecture.

The breakdown structure of the program, composed by PCOs objects (see Fig. 4), and similar between NP02 and NP04, has been defined following the functional analysis, received as input.

The PLC used to control the common services can work in three different modes depending on which experiments are running, and it controls the storage and the distribution of argon and nitrogen for the two experiments.

Similarly, NP02 and NP04 can work in different modes, depending on the phase where the process is at (e.g., cool-down or filling). It's possible to see a portion of the NP04 breakdown structure in the Fig. 4.

Commissioning

Several activities, aimed to test the correct implementation of the control system, have been performed to bring the cryogenic system in working conditions. The sequence of activities that will be described here during the commissioning was nearly the same for NP04, NP02, and WA105, and they were monitored through the WinCC OA panels (see Fig. 7) that were part of the control system realization.

Firstly it was performed a synchronization test, to verify that all the input and output signals were adequately connected to the PLC. Concerning the NP04 and NP02 experiments, this task required to verify about 1000 signals divided as following: 299 AI, 490 DI, 91 AO, 132 DO.

The experiments also rely on the exchange of signals between cryogenic and other systems involved in the projects. In particular, the cryogenic system, measuring the vacuum pressure in the transfer lines, sends as a warning to the other systems the potential risk of argon leaks from the transfer lines. In case this happens, safety procedures will start, as

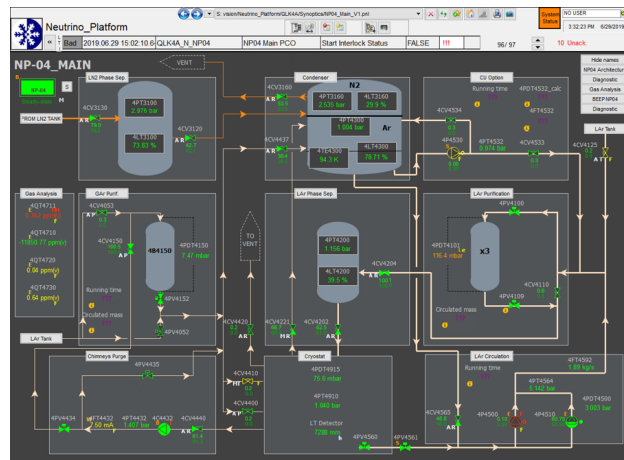

Figure 7: NP04 WinCC OA main view.

the evacuation, the air extraction, and the cooling and ventilation of the building. Similarly, the cryogenic system receives an alarm in case ODH is detected by the responsible service, and it triggers interlocks accordingly.

Following the CERN level 3 alarm procedures, an official test with the Safety unit officers has been performed between all the involved parts, to ensure the correct hardwired communication between them.

The way the communication of potential argon leak to other systems has been designed allows the application of a security protocol to ensure a transparent upgrade of the control system at any moment without risking of sending fake potential alarms (e.g., during the restart of the PLC).

After these tests, the cryogenic control system was put in working conditions and the cryogenic process started.

Once that a required purity level of the argon injected in the system was reached during the purge in open and closed loop, the cool-down of the cryostat was started, using the condensation of the argon through the nitrogen. During the cool-down of NP04, due to mechanical problems that did not allow the usage of the foreseen cooling down process, a fast on-line intervention was performed to adapt the control system to the requirements of the new strategy, through a modification of the PLC program and consequently of the SCADA system to keep the consistency between the PLC content and the monitoring system. This required as well the addition of new alarms and interlock objects to prevent the exposure of the cryogenic installation to abnormal situations.

When the cryostat reached low temperatures around the 85 K (see Fig. 8), this was filled during four weeks with about 1 kTon of liquid argon and then put in stable conditions.

CONCLUSION

Based on the LHC cryogenic system operational experience [3], the implementation of the control system for the three projects has been considered successful, encountering characteristics such as flexibility, maintainability, availability, and protection.

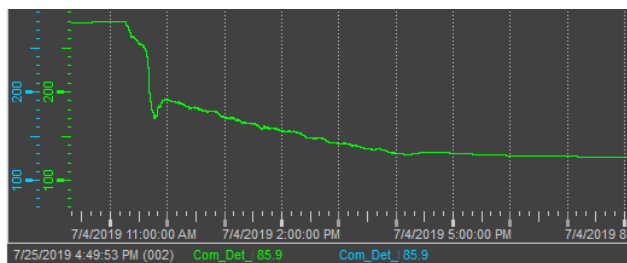

Figure 8: NP02 Cool-down trend.

The WA105 test facility ran successfully for a longer time than expected, requiring few maintenance interventions and proceeding smoothly until the end of the experiment.

The NP02 and NP04 experiments have been instead much more demanding, with the consequence of stressing and remarking much more these characteristics, in particular flexibility and maintainability.

In fact, several control system hardware and software consolidations and improvements were implemented during the commissioning and also during the operations under stable conditions. Keeping the consistency between the control data and the documentation has been very challenging but vital for the maintenance and the support to the operation.

Nevertheless, the system has proven to be highly reliable and available: in case of power cuts, the PLC and the monitoring system kept working, sending phone calls to the operators to warn them about the issue and keeping the process working.

REFERENCES

- [1] Git. <https://git-scm.com/>
- [2] Jenkins. <https://jenkins.io/>
- [3] B. Bradu *et al.*, “Process control system evolution for the LHC Cold Compressors at CERN,” 2019.
- [4] A. Moraux, J. Bremer, V. Falaleev, A. Gonidec, G. Passardi, and M. Pezzetti, “The Upgrade of the Control System for the CERN/NA62 Liquid Krypton Detector,” no. CERN-AT-2008-030, pp. 483–489, Jul. 2008. <https://cds.cern.ch/record/1173053>
- [5] V. Inglese, M. Pezzetti, and E. Rogez, “The CERN revamping project of the obsolete cryogenic control systems: Strategy and results,” vol. 1434, pp. 491–498, Jun. 2012. doi:10.1063/1.4706956
- [6] J. Casas-Cubillos, P. Gayet, P. Gomes, M. Pezzetti, C. H. Sicard, and F. J. Varas, “Application of Object-Based Industrial Controls for Cryogenics,” no. CERN-LHC-2002-007-IAS, 4 p, Jul. 2002, revised version number 1 submitted on 2002-07-15 09:27:42. <http://cds.cern.ch/record/567337>
- [7] C. Fluder *et al.*, “The development of the control system for the cryogenics in the lhc tunnel,” Tech. Rep., 2011.
- [8] C. Fluder, V. Lefebvre, M. Pezzetti, P. Plutecki, A. Tovar-González, and T. Wolak, “Automation of the software production process for multiple cryogenic control applications,” in *Proc. ICALEPCS’17*, Barcelona, Spain, 2017, pp. 375–379. doi:10.18429/JACoW-ICALEPCS2017-THPHA162
- [9] B. Copy, E. Mandilara, I. Prieto Barreiro, and F. Varela, “Monitoring of CERN’s Data Interchange Protocol (DIP) system,” in *Proc. ICALEPCS’17*, Barcelona, Spain, 2017, pp. 1797–1800. doi:10.18429/JACoW-ICALEPCS2017-THPHA162
- [10] SIMATIC WinCC Open Architecture Portal. <https://www.winccoa.com/>