

BB



LYCEN/9440
November 1994

NUCLEAR SPECTROSCOPY OF EXOTIC NUCLEI WITH THE SARA/IGISOL FACILITY

R. Béraud^{1*}, A. Emsallem¹, J. Ärje², A. Astier¹, J. Äystö²,
D. Barnéoud³, R. Duffait¹, J. Genevey³, A. Gizon³, P. Jauho²,
Yu. A. Lazarev⁴, Y. Le Coz¹, N. Redon¹, Y.V. Shirokovsky⁴

- ¹ Institut de Physique Nucléaire de Lyon
IN2P3-CNRS/Université Claude Bernard
43, Bd du 11 Novembre 1918, 69622 Villeurbanne Cedex, France
- ² Department of Physics
University of Jyväskylä
P.O. Box 35, SF-40352 Jyväskylä, Finland
- ³ Institut des Sciences Nucléaires de Grenoble
IN2P3-CNRS/Université Joseph Fourier
43, Avenue des Martyrs, 38026 Grenoble Cedex, France
- ⁴ G.N. Flerov Laboratory of Nuclear Reactions
Joint Institute for Nuclear Research
Moscow District, Russia

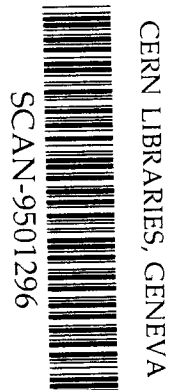

SW 9505

* Invited talk presented at :

Third IN2P3-RIKEN Symposium on Heavy Ion Collisions,
Oct. 24-28, 1994
Osato-Gun (Japan)

I. Introduction

The study of nuclei far off the valley of stability offers the possibility to extend nuclear structure data as a function of isospin so that more stringent tests of nuclear model predictions become possible.

We review our recent studies on alpha and beta decay of exotic nuclei performed with the IGISOL on-line mass separator at SARA in Grenoble. The experiments using charged particle induced fission have given new information on production cross-sections [1] and properties of n-rich nuclei with $A=110-130$ whereas by means of HI-induced fusion evaporation reactions we have investigated two regions close to the proton drip line around $A=180$ and $A=130$.

One of the physics goal of our investigations was to understand the gradual change of nuclear structure from a spherical vibrator to a deformed rotor when going from doubly magic ^{132}Sn to the highly deformed ^{100}Zr . In fact, we have found a transition region with rather strongly deformed nuclei among the most n-rich Ru isotopes with a breaking of axial symmetry [2].

The discovery of EC/ β^+ -delayed fission of ultra-neutron deficient isotopes in the region of Mercury-Lead [3] and the lack of data on their decay properties were mainly at the origin of our experimental programme on the Tl isotopes. New insight on fission barrier of cold nuclei may be gained from these investigations.

The n-deficient rare-earth nuclei with A around 130 are well-known to belong to a so-called transitional region where quasi-neutrons and quasi-protons may occupy $h_{11/2}$ shells. From in beam studies a lot of deformed and superdeformed bands have been observed but their connection with the low-lying levels is often an open problem. Its solution can be found thanks to a precise knowledge of level schemes at low excitation energy which can be obtained from β -decay studies [4]. Our most recent experiments involving also search for proton-radioactivity will be reported.

In this paper we first give a brief description of the IGISOL (Ion Guide base Isotope Separation On Line) technique and show its applications in case of two different production modes : charged particle-induced fission and HI-induced fusion-evaporation reactions.

II. Experimental techniques

Since 1982, the ISOL method has been applied at SARA in Grenoble for the study of nuclei produced via heavy-ion (HI)-induced fusion-evaporation reactions. Initially developed with an integrated target-ion-source [5] suitable for volatile elements, the method has been extended to refractory elements by connecting a He-jet to a medium-current source [6]. This allowed us to overcome the problem of delay time from the catcher material which was a severe limitation to the study of isotopes with half-lives shorter than a few tens seconds in case of non-volatile species. Thus a large number of n-deficient isotopes have been identified and studied in the light rare-earth region. In this technique the delay time which is approximately the

transit time in the capillary of the He-jet system (typically a few tens ms/m) cannot be avoided and moreover taking into account the maximum He flow rate compatible with the working pressure of the ion source, it was not possible to go much lower than 1s range.

A decisive progress was made with the IGISOL technique, pioneered by the Jyväskylä group [7], in which the delay time between production and detection after mass separation is mainly due to the mean evacuation time of the He-pressurized recoil chamber. This group has shown that in the case of light ion-induced fusion-evaporation reactions, the overall transmission efficiency can be of the order of 1% even for isotopes with short half-lives down to 100 μs [8]. In addition, the IGISOL technique has very stable operating conditions and its chemical non-selectivity makes it very attractive for refractory elements. Its basic principle takes advantage of the fact that nuclear reaction products recoiling out of a target and thermalized in He, may survive as singly charged ions for about 10 ms. This time is usually long enough to extract the ions via the gas flow and to transfer them for further acceleration into a conventional on-line isotope separator.

Because of the so called "plasma effect" [9] its application in on-line mass separation of products from HI reactions was rather limited [10]. In this case the primary beam creates a dense plasma in the recoil chamber so that the overall efficiency is considerably reduced. The HI beam suppression can be achieved using different methods : the most straightforward one has been applied at RIKEN by means of a high efficiency gas-filled recoil separator (GARIS) [11], an alternative one is the "shadow" method which we applied and will be described in section II.C.

In case of light-ion-induced fission reactions, the nearly isotropic angular distribution of the fragments makes the separation of reaction products from primary beam easier. The concept of double chamber proposed at first by Taskinen *et al.* [12], has been applied in many laboratories and our own version will be described in section II.B.

A/ General layout of the ISOL facility

Figure 1 gives a perspective view of the cave where the IGISOL has been installed together with a low background detection area. The isotope separator based on a 120° angle magnet (0.75 m mean radius and $n=1/2$ field index) has been described in detail previously [6], it has been equipped with a new general purpose vacuum chamber which can fit with versatile ion source systems.

As to thermalize high energy recoil products (in fission or HI reactions) with maximum efficiency in a small volume we have to increase the He pressure, a very high speed pumping system has been installed in the basement of the cave. It is composed of a set of Roots blowers (8000 m³/h+3000 m³/h+1000 m³/h) and a primary pump (120 m³/h) connected to the ion guide chamber via a 350 mm diameter, 3 m long pipe. To prevent from sparks the whole system is operating at high voltage (routinely 25 kV). The second stage of the differential pumping, between

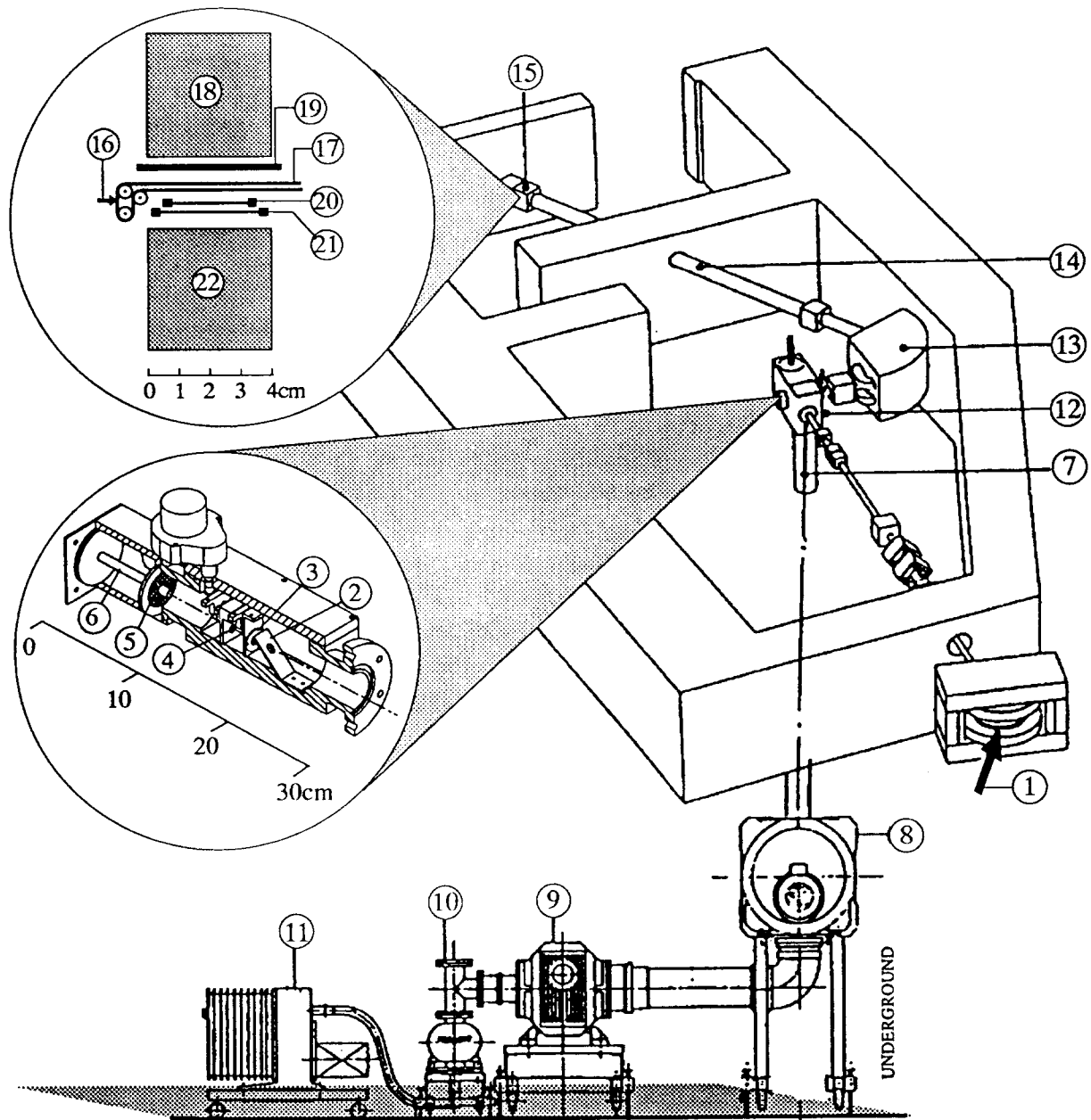

- | | | |
|-------------------------|---------------------------------------|-----------------------------|
| ① SARA beam | ⑧ 8000 m ³ /h Roots blower | ⑯ Mass separated beam |
| ② ZnS diaphragm | ⑨ 3000 m ³ /h Roots blower | ⑰ Transport tape |
| ③ Graphite diaphragm | ⑩ 1000 m ³ /h Roots blower | ⑱ N- type Ge detector (60%) |
| ④ Target | ⑪ 120 m ³ /h Primary pump | ⑲ 1 mm plastic scintillator |
| ⑤ Entrance window | ⑫ Skimmer and acceleration | ⑳ 25 μm Si detector |
| ⑥ Beam suppression tube | ⑬ Magnet | ㉑ 500 μm Si detector |
| ⑦ Pumping line | ⑭ Einzel lens | ㉒ 4 cm plastic scintillator |
| | ⑮ Counting station | |

Figure 1 : Layout of the SARA/IGISOL facility.

skimmer (negatively biased) and extraction electrode (at ground potential) is evacuated with a 8000 l/s oil diffusion pump.

The details of the set up and control devices have been reported in a previous paper [13].

B/ Double chamber for fission fragments

This is a modified version of a chamber designed by Taskinen *et al.* [12] already mentioned. The stopping volume have been increased from 8 to 20 cm³ and is fed by six $\phi=3$ mm He ducts which ensure laminar flow pattern around the separation foil to the $\phi_2=1.2$ mm exit aperture (see ref. [13] for details). The target chamber contains four ~ 15 mg/cm² ²³⁸U targets covered with 0.2 mg/cm² Al and is fed by He in parallel with the stopping chamber. Spontaneous or induced fission of heavy nuclei are among the most prolific mechanism to produce a great variety of neutron-rich nuclei. In case of 20 MeV protons or 40 MeV alpha particles induced-fission of ²³⁸U, the absolute cross-sections in the valley of the mass distribution are comparable to those of the thermal n-induced fission. Owing to its short separation time and independence on chemical properties, the IGISOL technique has proved that it was quite suitable for the study of shortlived nuclei of refractory elements from Y to Pd in the mass range A=110-120. More than twenty new isotopes have been discovered so far by the Jyväskylä group [14] and the particular case of a collaborative work on the n-rich Ru isotopes will be addressed later.

C/ Chamber for HI-induced fusion-evaporation reactions

One of the best way to produce n-deficient nuclei consists of using HI-induced fusion-evaporation reactions in which both target and beam particle are n-deficient. In this case, the concept of double chamber is no more applicable since the reaction products are strongly forward peaked. To avoid the plasma effect we have applied the "shadow" method successfully used in laser spectroscopy experiments by Sprouse *et al.* [15]. Basically the method takes advantage of the huge difference of the primary beam angular distribution and that of the evaporation residues (EVRs) after passing a thick target (about a few mg/cm²). The main physical effects governing these distributions have been discussed in a recent paper [16] where it has been shown that multiscattering in the target was of major importance compared to finite angular spread of projectile beam and kinematical effects due to particle evaporation after fusion. The angular distributions show that for ¹⁴⁴Sm target thickness between 1 and 3 mg/cm² the primary ⁴⁰Ca beam is confined within 1° angle whereas the EVRs are spread over a 15° angle. In principle, a simple geometrical arrangement (beam stop or beam channel) enables to suppress more than 99% of the primary beam whereas more than 50% of EVRs can enter the recoil chamber for thermalization.

III. Spectroscopic results

A/ Triaxiality in n-rich Ru isotopes

In e-e nuclei, the spacings observed in sequences of low-lying levels together with the strengths of electromagnetic transitions are currently used to provide evidence of the rotation of rigid nuclei with various shapes. The case of triaxial deformations is of special interest regarding this thirty years old question whether axially asymmetric nuclei are γ -unstable or rigid triaxial rotors.

The systematics study of n-rich e-e Pd, Ru, Mo and Zr isotopes is of great interest to understand the gradual shape change from spherical vibrator to deformed rotor. Our investigations have been focussed on the low-lying collective levels of $^{110,112}\text{Ru}$ fed by the beta decay of $^{110,112}\text{Tc}$ produced via charged particle-induced fission of ^{238}U and mass-separated using the IGISOL technique described in section II-B. In addition to the discovery of the new shortlived (280 ms) ^{112}Tc isotope, we have observed in ^{112}Ru one of the lowest second 2^+ state ever reported (except in ^{192}Os). Figure 2 shows the summary of the experimentally known low-lying collective levels in n-rich Ru nuclei obtained from our work [17] and previous data [18]. Results concerning ^{114}Ru have been obtained in a very recent experiment by measuring prompt γ -rays in ^{248}Cm fission fragments with the EUROGAM large detector array [19]. From this figure it can be seen that near the middle of the N=50 and 82 neutron shells the g.s. bands ($0^+2^+4^+$) are rather similar whereas the second 2^+ and first 3^+ levels, which belong to the γ -band, have gradually decreasing excitation energies with a minimum occuring in ^{112}Ru .

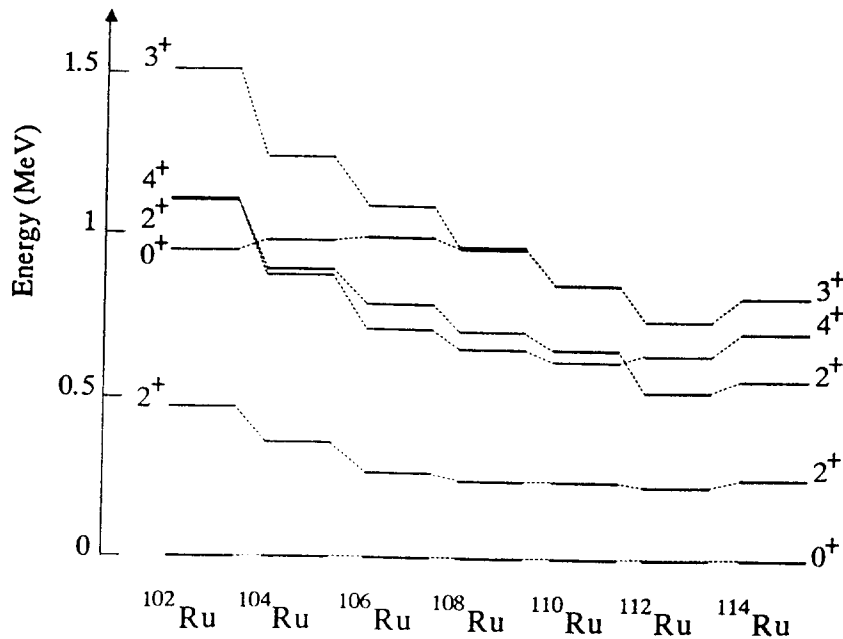

Figure 2 : Some low-lying levels of $^{102-114}\text{Ru}$ isotopes.

On the basis of the two well-known empirical criteria, i.e. the position of the 2_2^+ state below the 4_1^+ state and the sum relation on the 3_1^+ energy, it is obvious that $^{110,112}\text{Ru}$ and ^{114}Ru can adopt triaxial shapes in their ground states. In terms of the rigid triaxial rotor model of Davydov and Filippov [20], the γ values (deduced from the energies of the two 2^+ levels) are 24.2° , 26.4° and 27.2° for $A=110$, 112 and 114 respectively. The agreement is also good for $B(E2)$ ratios as was established in ref. [17] and more extensively in ref. [19]. Microscopic lattice Hartree-Fock calculations for $^{108,110,112}\text{Ru}$ [17] similar to those developed by Bonche *et al.* [21] have shown that the n-rich Ru are strongly deformed with a quasidegeneracy in the γ -direction. The minima predicted in the γ valley are too shallow to ensure a rigid axial asymmetry as indicated by the level spacings.

It becomes suggestive when comparing the level spectra of n-rich Ru nuclei with the Ba isotones in the valence nucleon scheme, that it is the large neutron excess which drives the structure towards soft triaxiality.

B/ Decay properties of very n-deficient Tl isotopes

Until now there are only very scarce data on the g.s. decay properties of the lightest Tl isotopes ($A < 184$) as compared to extremely n-deficient neighbouring Pb, Hg and Au nuclides. Besides the evident general interest of exploring properties of isotopes close to the proton drip line, there is a number of particular reasons stressing the importance of the determination of the g.s. decay pattern of ^{180}Tl . This nucleus can undergo many decay modes as shown in Figure 3 with estimated energies from ref. [22].

First EC-delayed fission was observed and assigned to ^{180}Tl [3] precursor. Second, α -decay properties are poorly known for ground states and isomeric states of Tl isotopes with $A \leq 183$. Third, does large deformation as observed in this region for g.s. of $^{183,185}\text{Hg}$ strongly affect decay properties. As to ^{180}Tl specifically its half-life was deduced from EC-delayed fission studies to be $T_{1/2} = (.97_{-0.08}^{+0.09})\text{s}$ [3]. In this work, the assignment was based on many cross-bombardments and by involving g.s. decay properties of nuclei in this region as well as systematics of H.I.-induced fusion-evaporation reactions. However, it should be corroborated by direct experiments. An attempt was performed at the IRIS-facility using mass-separation of products from 1 GeV protons induced spallation on the ThC_x target. In this experiment no α -particle which could be assigned to the decay of ^{180}Tl have been observed. The high energy part of β spectrum ($4.5 < E_\beta < 6.5$ MeV) at this mass number was attributed to Tl arguing that the β -endpoint energy for the daughter ^{180}Hg is less than 4.5 MeV. Some 60 counts were detected and a half-life of $(1.9 \pm 0.9)\text{s}$ was obtained for ^{180}Tl [23]. These results cannot be considered as an unambiguous identification of the isotope.

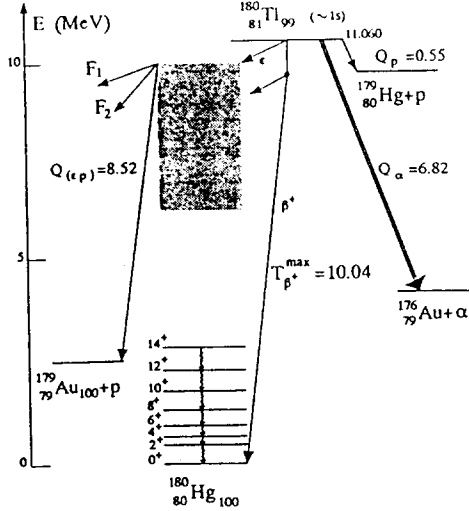

Figure 3 : Possible decay modes for the nucleus ^{180}Tl , the decay energies are derived from atomic mass evaluation of ref. [22].

The aim of the present work was to identify ^{180}Tl and study its α -decay properties by using induced fusion-evaporation reactions and mass separation technique of the IGISOL type.

In our experiment ^{144}Sm targets enriched to 86% involving also ^{147}Sm (4%), were bombarded with $^{40}\text{Ca}^{11+}$ beams accelerated by the K=90 cyclotron of the SARA facility. We used 3 mg/cm² targets of $^{144}\text{Sm}_2\text{O}_3$ on 1.1 mg/cm² Al backings. Bombarding energy at mid-target was chosen to be ~ 210 MeV according to systematics and statistical-model expectation of the energy position for the maximum yield of the (p3n) evaporation channel.

Typical intensities of ^{40}Ca beams were in the range 10 to 30 pA. Shown in Figure 4 is the sum α -particle energy spectrum for the mass chain $A=180$ in case of the $^{144}\text{Sm}+^{40}\text{Ca}$ reaction. Both the collection and counting time intervals were set to be 2 seconds in this case. It is seen here that the well-known 6.120 MeV α -line from ^{180}Hg having a half-life of $(2.56 \pm 0.02)\text{s}$ and an α -decay branching of 35% [24] has been produced and mass-separated. The width of the α -line is in agreement with the energy resolution of our SB Si detector (500 μm , FWHM=37 keV at 5.486 MeV) which was calibrated with standard α -sources (^{239}Pu , ^{241}Am , ^{244}Cm). In the α -particle energy range around 5.75 MeV, the daughter α -activity of ^{180}Hg is present in full agreement with the α decay properties known for ^{176}Pt ($T_{1/2}=6.3$ s, $b_\alpha=41\%$, $E_\alpha=b_\alpha$ 5.750 MeV) [25]. The ratio of the peak areas of the two α -lines are in good agreement with the decay properties of the $^{180}\text{Hg} \rightarrow ^{176}\text{Pt}$ after taking into account corrections associated with the 2 s collection and 2 s counting times.

Further, in Figure 4 an α -line of 6.07 ± 0.02 MeV is clearly seen, the area of which represents about 30% of that of the 6.120 MeV α -line of ^{180}Hg . This is a new α -line in the $A=180$ chain because it was not observed in the detailed on-line mass-separation studies performed with the $^{144}\text{Sm}+^{40}\text{Ar}$ reaction [25]. There are also seen in Figure 4 weaker α -groups between 5.80 and 6.05 MeV, whereas above 6.15 MeV only very weak α -activities are present.

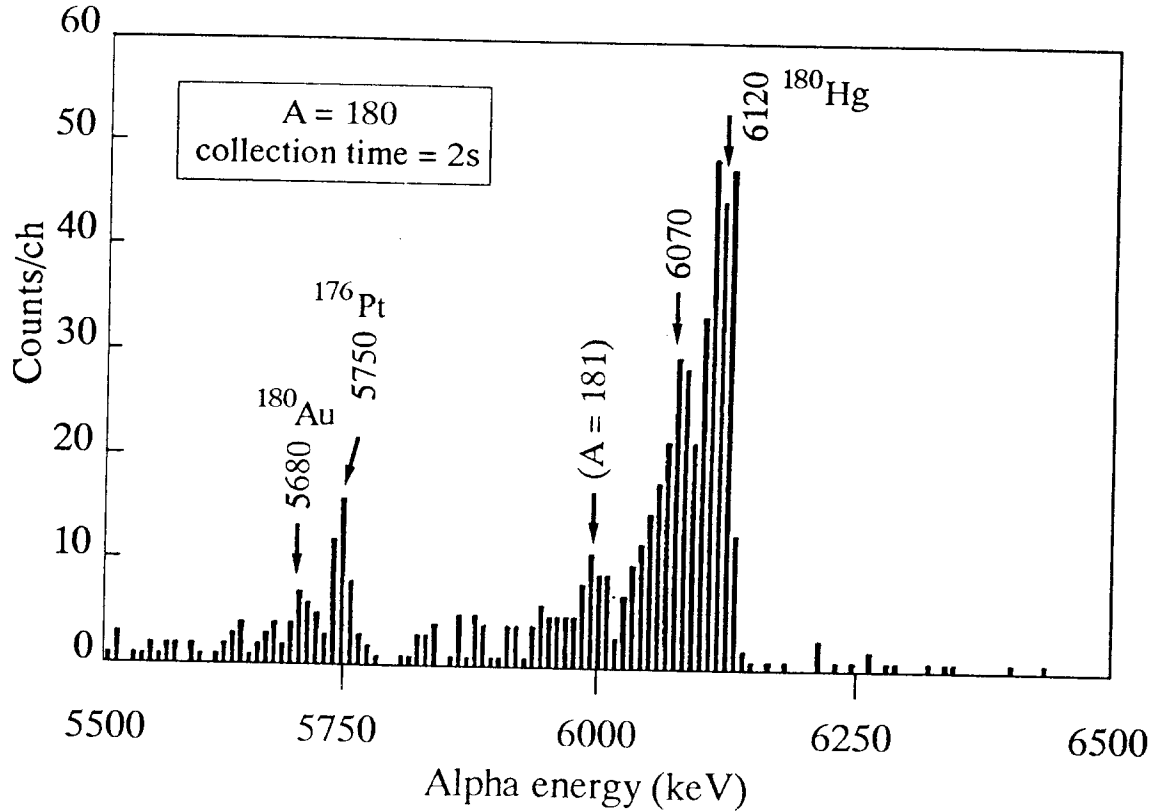

Figure 4 : α -particle spectrum measured at mass $A=180$ for the reaction $^{144}\text{Sm} + ^{40}\text{Ca}$. Collection and counting time intervals were equal to 2 seconds.

Obviously, no α -line at 6.07 MeV can be seen in the α -spectrum measured at $A=181$ mass chain, and moreover a possible contamination due to the neighbouring ^{180}Hg can be neglected. It is also worth noting that there is no α -activity beyond ~ 6.15 MeV.

The experimental data presented above give good grounds to attribute the 6.07 MeV α -line to the decay of ^{180}Tl . However, the energy of this line is too low to fit with the α -decay systematics in this region of nuclei. It is also worth mentioning the possible α -activity due to ^{174}Pt with similar half-life (~ 0.9 s) and $E_{\alpha}=6.038$ MeV which could be produced as a result of the 2p-decay of ^{180}Pb .

Complementary studies have been carried out at the Dubna U400 cyclotron by employing the Dubna gas-filled recoil separator. These bombardment allowed the experimental sensitivity to be increased by about 10^2 times compared to SARA experiments, although by price of replacing mass separation with only kinematic separation. The data collected at Dubna are presently under analysis.

C/ The region of n-deficient rare-earth nuclei

This region of nuclei around $A=130$, usually referred as a transitional region has been the subject of many experimental and theoretical investigations. At SARA a great number of experiments have been performed, using both the He-jet and IGISOL techniques to study the products of $^{92,94,96}\text{Mo}+^{40}\text{Ca}$ reactions. Several level schemes fed by beta decays have been established in Pr, Ce and La isotopes with $127 \leq A \leq 135$ and results are given in ref. [27].

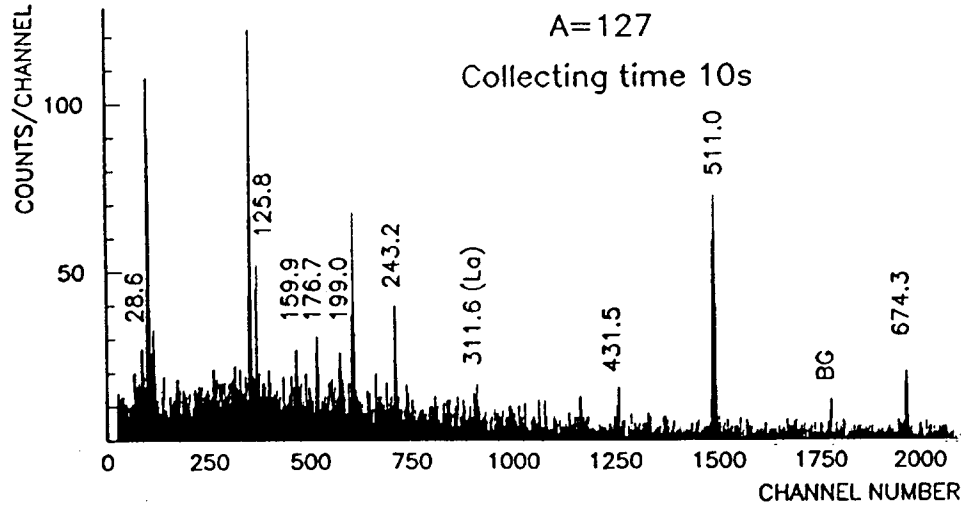
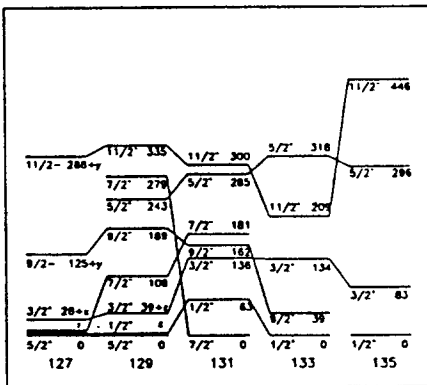

Figure 5 : β -gated γ spectrum measured at mass $A=127$ with 10s collection-and counting-time.

Among the recent results, the identification of the new isotope ^{127}Pr ($4 \pm 1s$) was achieved by measuring the β -gated γ spectrum of 127 mass chain (see Figure 5). The study of the $^{127}\text{Pr} \rightarrow ^{127}\text{Ce}$ EC/ β^+ decay is worth noting since it enabled us to establish the first excited levels of three collective bands in ^{127}Ce . Two of these bands based on $7/2^-$ and $5/2^+$ levels were already known from previous in-beam studies [28] whereas a third one of positive parity could be associated mainly with the $d3/2$ configuration [29].



The systematics presented in Figure 6 exhibits the low-energy levels assigned via our measurement in odd-A n-deficient Ce isotopes.

Figure 6 : Low-lying levels in odd-A Ce isotopes.

The proton drip line localisation is also of utmost interest in this region of the chart. It is well known that proton radioactivity which is one of the simplest decay process will determine the limits to nuclear stability for proton-rich nuclei. Nine proton emitters have been identified so far near ^{100}Sn and the closed neutron shell $N=82$. Taking into account the calculated masses, Q_p values may be derived and the partial proton half-lives can be calculated in a semi-classical way. Moreover from present data it is possible to speculate on the most neutron rich candidates for proton radioactivity between ^{109}I and ^{160}Re using the formula derived by Hofmann [30] : $Z=0.743 * N+11.6$. Along this line with $\Delta N=\pm 1$ (see Figure 7), about twenty nuclei can be considered for experimental investigations.

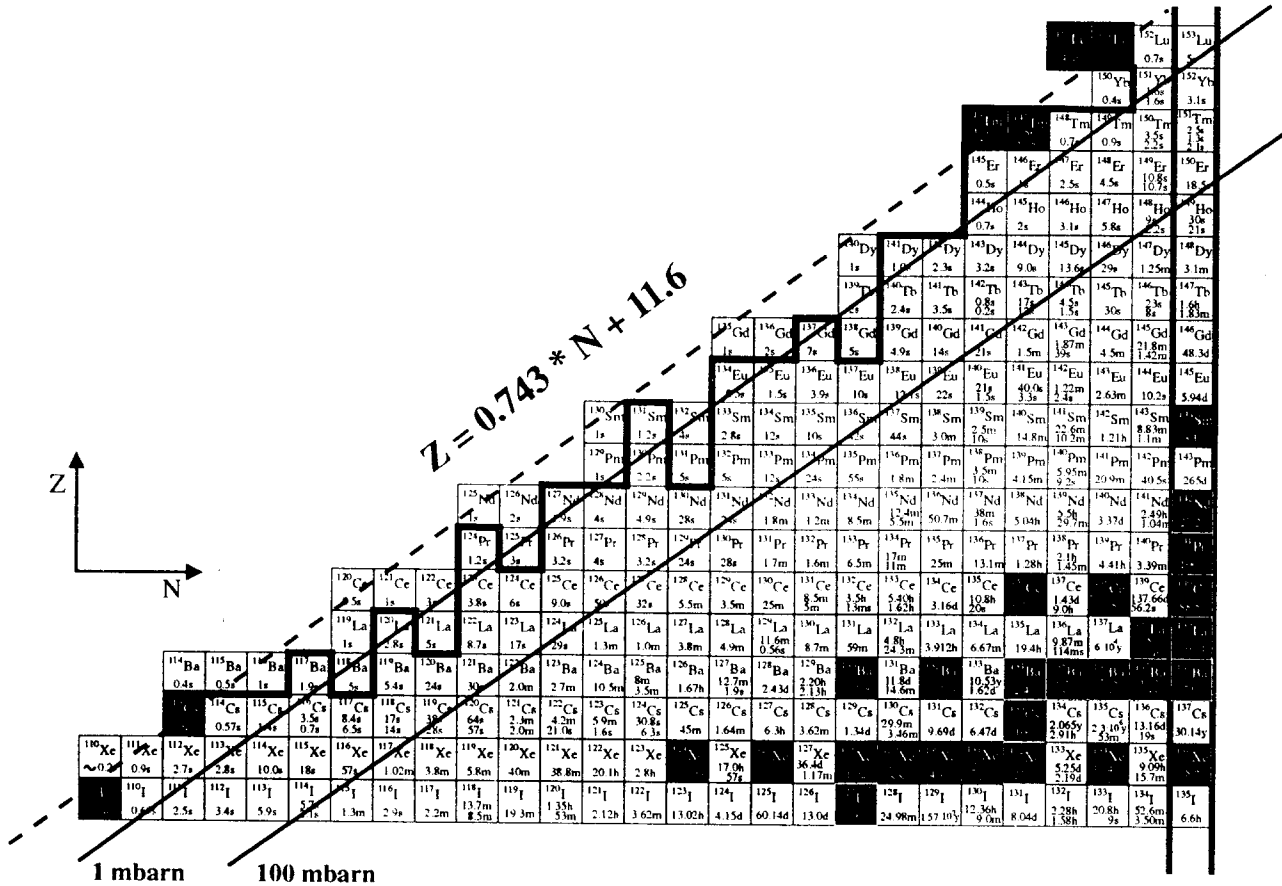

Figure 7 : Partial chart of nuclei along the proton drip line from ^{109}I to ^{151}Lu .

With stable n-deficient targets (^{92}Mo , ^{96}Ru) and intense beams of ^{36}Ar or ^{40}Ca available at SARA we plan to search for ^{118}La , ^{123}Pr , $^{127,128}\text{Pm}$ and ^{132}Eu which are expected to be produced with $\sim 100 \mu\text{barn}$ cross-sections via fusion-evaporation reactions. But, to be observed, the p-decay partial half-life value has to be in a rather limited time window due to both EC/β^+ decay competition and separation time of the IGISOL technique ($> 1 \text{ ms}$).

In addition with the strong dependence on Q_p value, the importance of angular momentum of single-particle proton parent state may affect the partial proton half-life by several orders of magnitude. The measurement of the proton energy value is of course of great importance since accurate nuclear masses can be derived and compared with theoretical predictions. Search for g.s. proton radioactivity in the mass 130 region is a challenge for experimentalists since higher sensitivity experiments have to be carried out, they are underway at SARA.

Summary

The systematic study of the low-lying levels in n-rich Ru isotopes has allowed us to show an axial symmetry breaking, whereas complementary investigations are needed to clarify the case of ^{180}Tl decay. A number of new spectroscopic data such as new isotopes identification, have been gained in the region of light rare earth nuclei.

The IGISOL technique which has been applied, up to now, for two types of reactions (fission and fusion-evaporation) has permitted many pioneering investigations on short-lived nuclei of refractory elements. The survival time of the singly charged ions in He (\sim a few ms) is nowadays a fundamental limitation to the efficient mass-separation of activities with much shorter half-lives. However it is worth noting that this technique is in its infancy and for example, its coupling with a laser source could provide in near future both an important increase of efficiency and selective ionization.

Acknowledgements

This work was done with the financial support of the Academy of Finland and the PICS-programme of CNRS (France) and also within the framework of the JINR Dubna-IN2P3 (CNRS) collaboration. One of the authors (R.B.) would like to emphasize that the contents of this text and talk have been strongly influenced by the SARA on-line isotope separator team work. He would like to express special thanks to M. Meyer, L. Ducroux (IPN Lyon), J. Blachot, J. Inchaouh (ISN Grenoble), A. Bouldjedri (Batna University), B. Weiss (University of Nice), I.N. Izosimov (Rad. Inst. St. Petersburg), A. Wojtasiewicz (Warsaw University), Z. Preibisz (INR Swierk), S. Chojnacki (Kielce University), G. Cata-Danil (IFA Bucharest), A. Jokinen, M.E. Leino, H. Penttilä, P. Taskinen (Jyväskylä University), K. Eskola (Helsinki University) with the technical support by R. Bouvier, R. Guglielmini, G. Margotton, J.P. Richaud, L. Vidal and J.L. Vieux-Rochaz.

References

- [1] Jauho P.P., *et al.* in Proc. First European Biennial Workshop on Nuclear Physics, Guinet D. and Pizzi J.R., Eds., Megève (France), 1991, p. 236, World Scientific.
- [2] Äytö J., *et al.* Nucl. Phys. A515 (1990) 365.
- [3] Lazarev Yu.A., *et al.*, Europhys. Lett. 4 (1987) 893.
- [4] Genevey J., *et al.*, Inst. Phys. Conf. Ser. 132 (1992) 671.
- [5] Tréherne J., *et al.* Z. Phys. A309 (1982) 135.
- [6] Plantier A., *et al.* Nucl. Instr. & Meth. in Phys. Res. B26 (1987) 314.
- [7] Ärje J., *et al.* Phys. Rev. Lett. 54 (1985) 99.
- [8] Ärje J., *et al.* Nucl. Instr. & Meth. in Phys. Res. A247 (1986) 431.
- [9] Morita K. *et al.* Nucl. Instr. & Meth. in Phys. Res. B26 (1987) 406.
- [10] Deneffe K., *et al.* Nucl. Instr. & Meth. in Phys. Res. B26 (1987) 394.
- [11] Nomura T., *et al.* Nucl. Instr. & Meth. in Phys. Res. A269 (1988) 23.
- [12] Taskinen P., *et al.* Nucl. Instr. & Meth. in Phys. Res. A281 (1989) 539.
- [13] Astier A., *et al.* Nucl. Instr. & Meth. in Phys. Res. B70 (1992) 233.
- [14] Äystö J., *et al.* Phys. Rev. Lett. 69 (1992) 1167 and ref. therein.
- [15] Sprouse G.D., *et al.* Phys. Rev. Lett. 63 (1989) 1463.
- [16] Béraud R., *et al.* Nucl. Instr. & Meth. in Phys. Res. A346 (1994) 196.
- [17] Äystö J., *et al.* Nucl. Phys. A515 (1990) 365.
- [18] Stachel J., *et al.* Z. Phys. A316 (1984) 105.
- [19] Shannon J.A., *et al.* Phys. Lett. B336 (1994) 136.
- [20] Davydov A.S. and Filippov B.F., Nucl. Phys. 8 (1958) 237.
- [21] Bonche P., *et al.* Nucl. Phys. A443 (1985) 39.
- [22] Audi G. and Wapstra A.H., Nucl. Phys. A565 (1993) 1.
- [23] Bolshakov V.A., *et al.* Inst. Phys. Conf. Ser. 132 (1992) 743.
- [24] Hagberg E., *et al.* Nucl. Phys. A318 (1979) 29.
- [25] Browne E. and Firestone R.B., Table of Radioactive Isotopes, 1986, Ed. Shirley V.S.
- [26] Wauters J., *et al.* Z. Phys. A345 (1993) 21.
- [27] Genevey J., *et al.* Inst. Phys. Conf. Ser. 132 (1992) 671 and ref. therein.
- [28] Nyakó B.M., *et al.* Z. Phys. A334 (1989) 513.
- [29] Genevey J., *et al.* Contribution to the International Conference on Nuclear Shapes and Nuclear Structure at Low Excitation Energies, Antibes, June 1994, France.
- [30] Hofmann S., Proc. Int. Conf. on the Future of Nuclear Spectroscopy, Crete, Greece, 1993, p. 255, Eds. W. Gelletly, C.A. Kalfas, R. Vlastou, S. Harissopoulos and D. Loukas.