

Commissioning of L1Calo Phase I Upgrade at ATLAS: development and testing of eFEX and FTM modules

Gareth Bird^{1,2}, Alan Watson¹, Chris Lester⁴, Dave Charlton¹, David Sankey², Edward Harry Flaherty⁴, Francesco Gonnella¹, Ian Brawn², Juraj Bracinik¹, Karen Hayrapetyan³, Marcella Bona³, Mohammed Siyad², Murrough Landon³, Nandish Gorasia¹, Norman Gee², Paul Daniel Thompson¹, Rhys Owen², Richard John Staley¹, Saeed Taghavirad², Stephen Hillier¹, Weiming Qian², Will Buttinger², Yuan Wang⁴

¹University of Birmingham ², STFC Rutherford Appleton Laboratory
³Queen Mary, University of London ⁴ University of Cambridge



Science and Technology Facilities Council



UNIVERSITY OF BIRMINGHAM

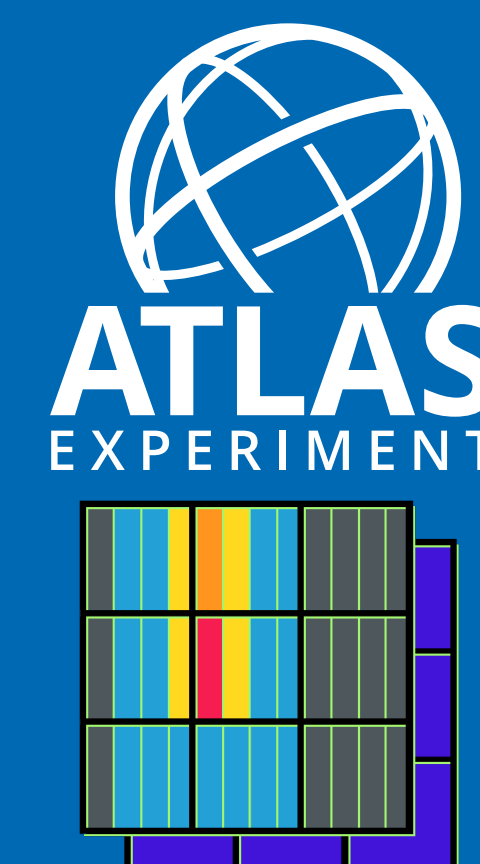

Abstract

The ATLAS level-1 calorimeter trigger (L1Calo) is a hardware system that identifies events containing calorimeter-based physics objects (e.g. jets, missing E_T , e/γ , τ s). In preparation for Run 3 with increased pileup, L1Calo is currently implementing a significant programme of planned upgrades. The existing hardware will be replaced by a new system of feature extractor (FEX) modules with improved input granularity and algorithms. Here we focus on the current ongoing testing and commissioning of the electron feature extractor (eFEX) and the FEX Test Module (FTM) at the recent slice tests at CERN. The online software developments required to do this are also discussed.

Introduction

To combat increased pileup, the ATLAS experiment for Run 3 LHC is using more sophisticated algorithms and more granular input data (fig. 1) in the Level 1 Calorimeter trigger (L1Calo). A new menu of trigger thresholds will be implemented by 3 new Feature EXtractor modules (FEX)[1]:

1. **eFEX**: generates e/γ and τ candidates using 0.025×0.1 (η, ϕ) input granularity with improved isolation variables compared to the 0.1×0.1 e/γ module in Runs 1 & 2
2. **jFEX**: generates **jet**, missing E_T and τ candidates using 0.1×0.1 input granularity compared to 0.2×0.2 in Runs 1 & 2
3. **gFEX**: '**global**' large R jets & missing E_T using larger 0.2×0.2 summed input data allowing whole calorimeter comparisons within the same algorithm block

Here we discuss commissioning efforts towards the eFEX and FTM through online software progress.

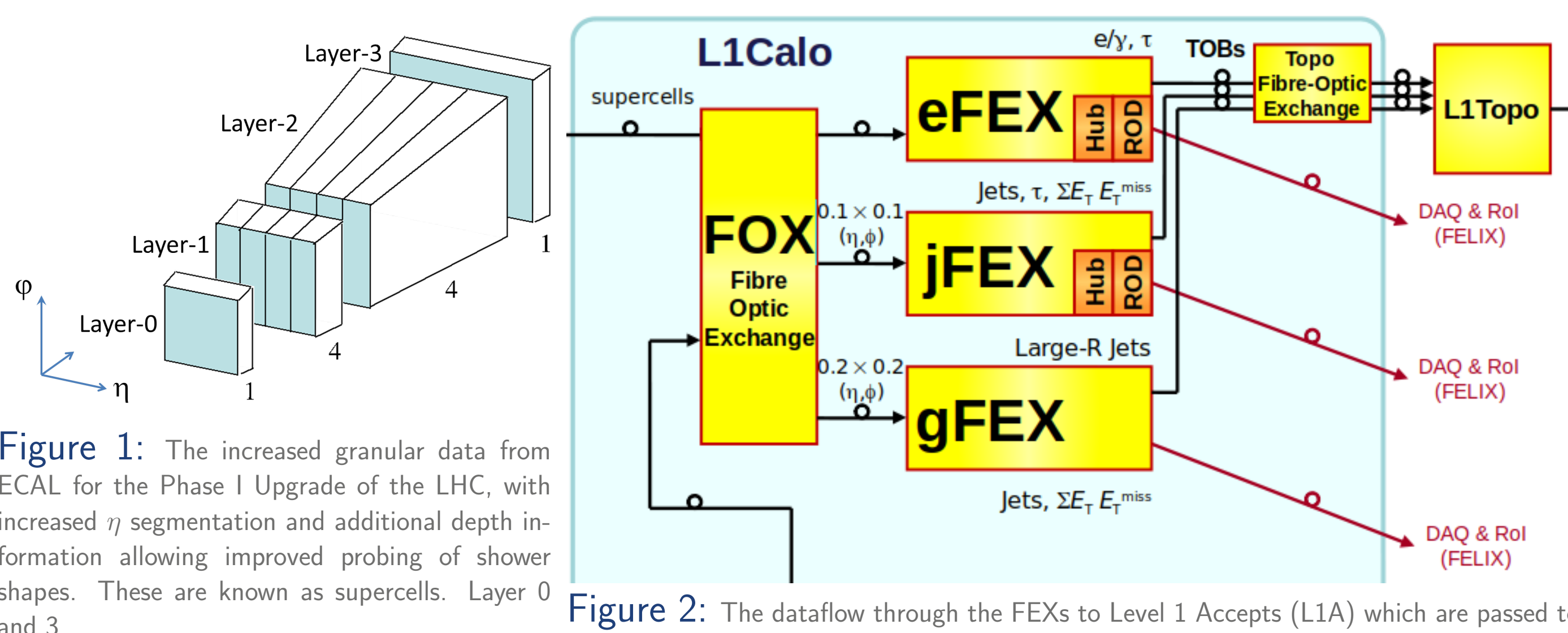

Figure 1: The increased granular data from ECAL for the Phase I Upgrade of the LHC, with increased η segmentation and additional depth information allowing improved probing of shower shapes. These are known as supercells. Layer 0 and 3

Figure 2: The dataflow through the FEXs to Level 1 Accepts (L1A) which are passed to the High Level Trigger for further processing.

The eFEX and FTM

A single eFEX module covers an area in (η, ϕ) of $1.6\pi/4$ and for each 0.1×0.1 looks for a 'seed': a local maximum over an extended 0.3×0.3 region to avoid several triggers off the same candidate. For each seed found it produces a Trigger Object (TOB) containing the coordinates, object E_T and results of isolation algorithms inspired by High Level Trigger measurement quantities evaluated in the 0.3×0.3 region. This is done through 4 Xilinx Virtex-7 FPGAs.

The FEX Test Module (FTM) is a module purely designed for ongoing commissioning activities. It contains 2 FPGAs containing RAMs loadable from software. These produce dummy data patterns that emulate input from other boards (source RAM) and can read in and compare to the simulated expected outputs (spy and ref RAM respectively). This is useful because we can emulate boards that may not be present for particular tests. It has been used in acceptance testing of L1Calo modules, system-level tests (where it has been invaluable) and commissioning.

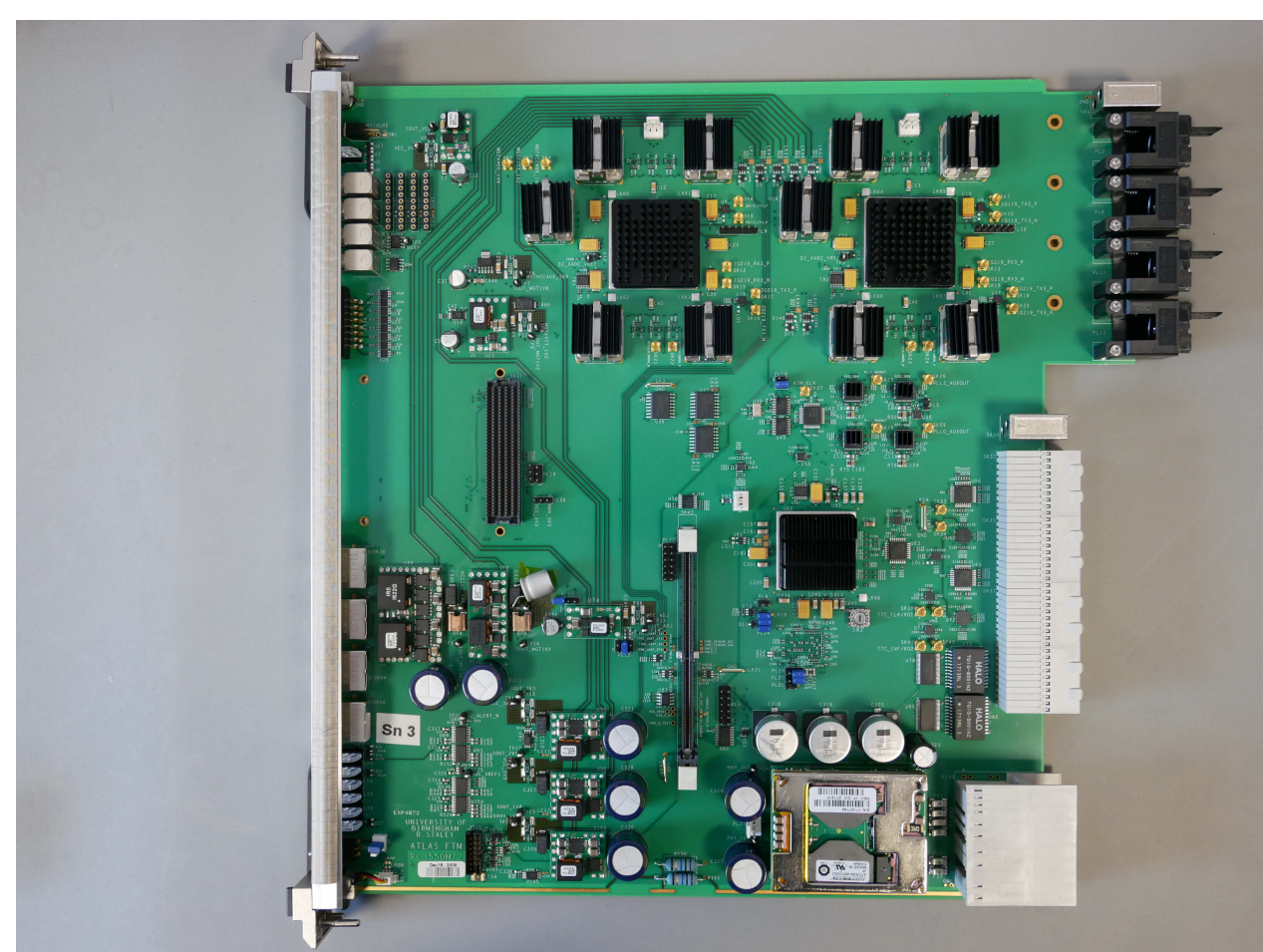

Figure 3: A production FTM

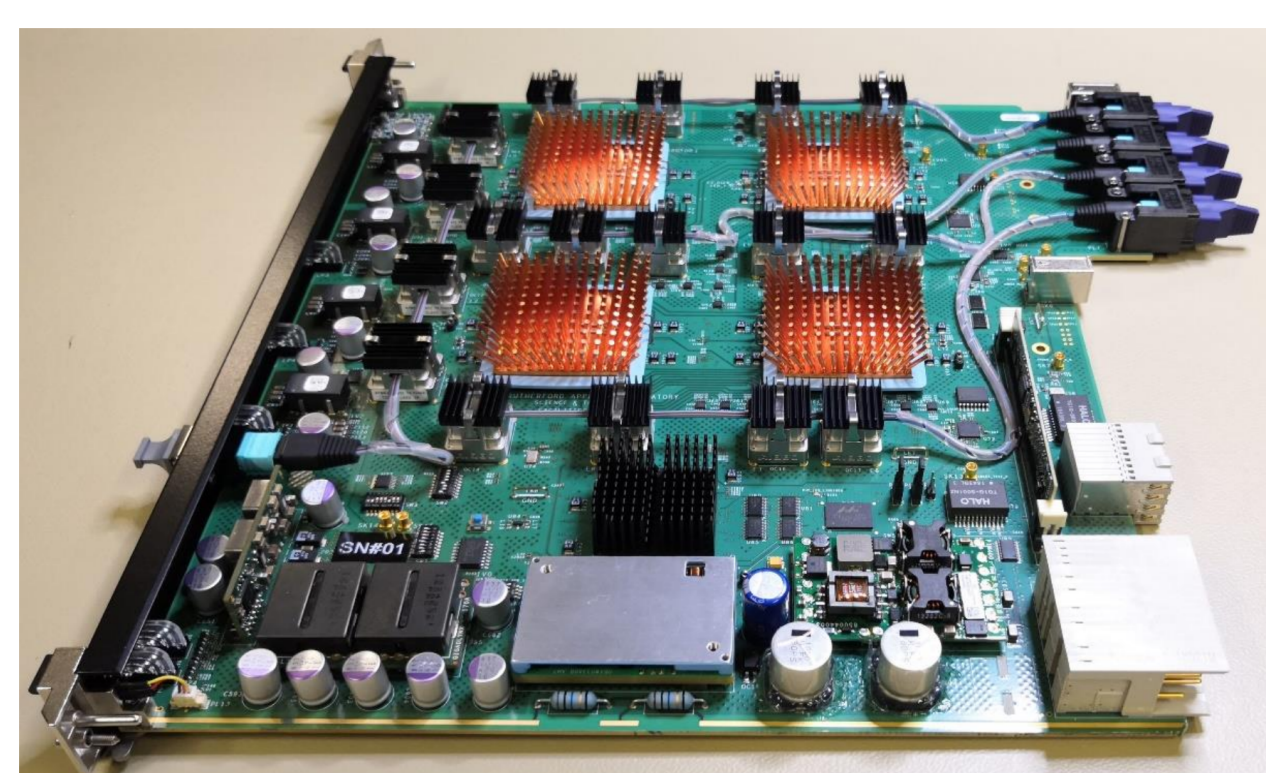

Figure 4: A pre-production eFEX module

L1Calo Online Software

To commission and operate L1Calo we require software that works within ATLAS Run Control software but also enables us to Run smaller tests. With the addition of 2 new modules operated in the UK many tasks need to be carried out to ensure operability and data validity of the new system. Here we outline two tasks.

eFEX Channel Mappings

With the increased granularity 'supercells' (fig. 1) from the calorimeter, the input data has additional complexity in terms of variable (η, ϕ) widths and depth information. To have correct emulation of eFEX dataflow we need to combine data from three sources:

1. FOX (Fibre Optic eXchange) which maps the calorimeter fibres to the individual FEXs
2. The liquid argon calorimeter's data word packing conventions within each fibre (giving us the depth information)
3. Internal information about eFEX hardware

These are parsed and combined into a complete set of tables described by fig. 5 and output as a csv file. These are then maintained in repository describing the exact sources we retrieved the data from.

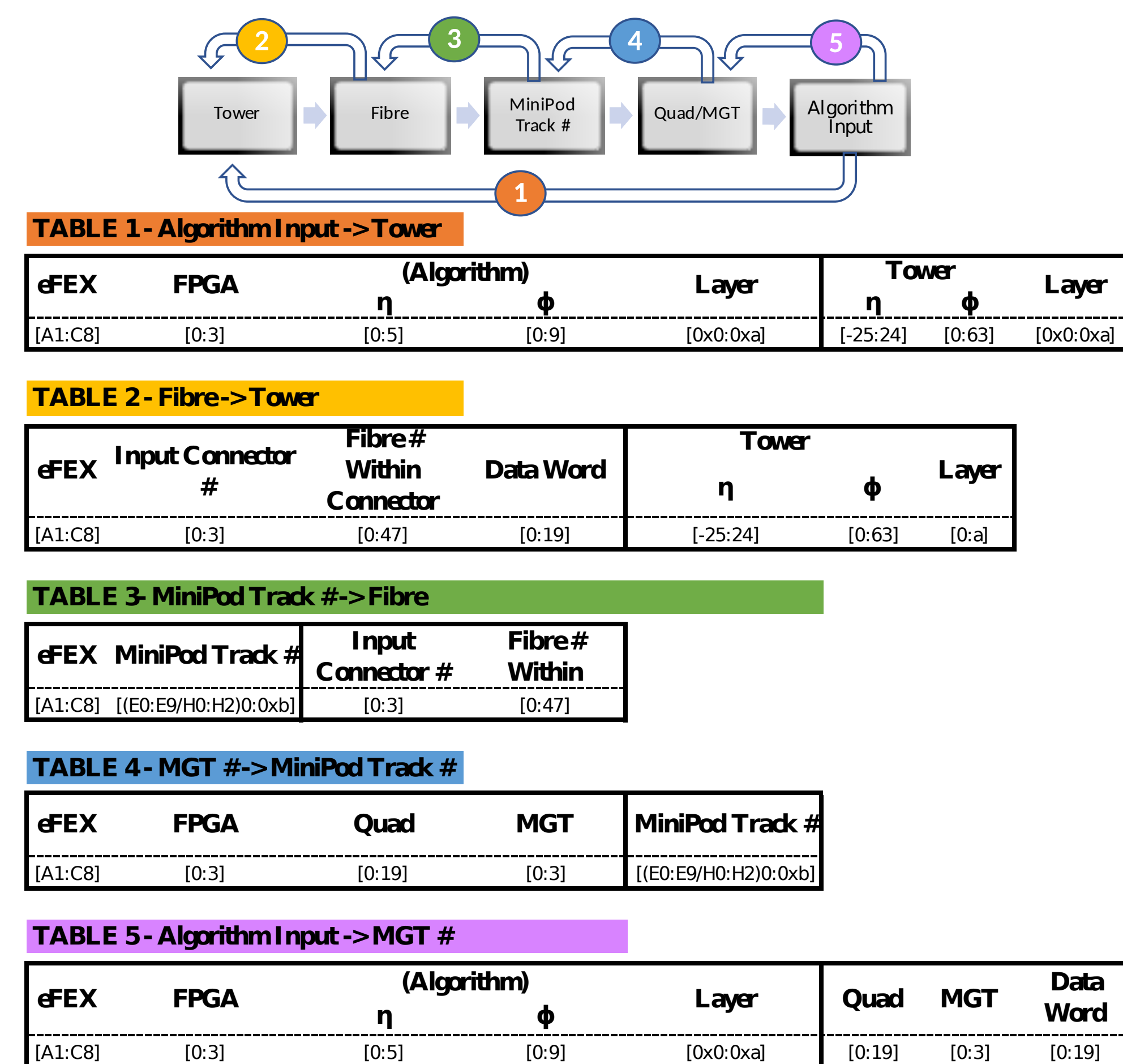

Figure 5: The channel mapping tables required to go to and from global/local algorithmic information to hardware specific description of a tower (a 0.1×0.1 area in the calorimeter). [2]

These csv files are then used within online software through a set of csv wrappers which are called by online software which can return various pieces of algorithmic information when called by hardware location & data word within a fibre.

FTM Loopback Tests

To validate the dataflow and algorithm functionality from the eFEX and the FTM we need to gradually build up more complex tests within online software. This has the end goal of being able to emulate medium scale data patterns with 2 FTMs acting as calorimeter input and then comparing trigger objects to expectation from simulation, all within online software.

As a first step, we direct the FTM source back into its sink either internally or with fibres (fig. 6) and check output matches input. This tests optical connections and basic functionality. This can be done manually or via automation in software that can then be broadened to more extensive tests.

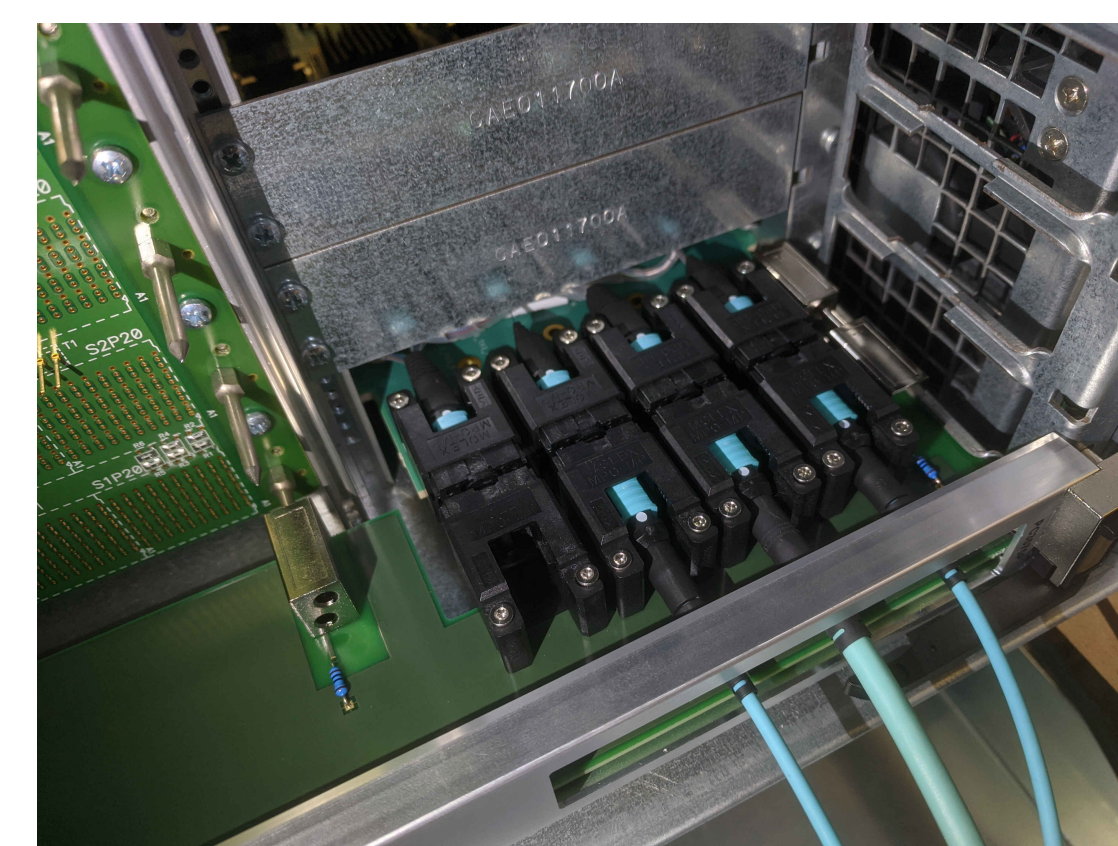

Figure 6: The loopback fibres plugged into the back of FTM (fig. 3) in a crate to enable fibre loopback

	FTM0-DSS1 MGT_Source_Ram	FTM0-DSS1 MGT_Sink_Ram Sink00
00000000	bc	00000000
00000001	1	00000001
00000002	2	00000002
00000003	3	00000003
00000004	4	00000004
00000005	5	00000005
00000006	6	00000006
00000007	7	00000007
00000008	0	00000008
00000009	0	00000009
0000000a	0	0000000a
0000000b	0	0000000b
0000000c	0	0000000c
0000000d	0	0000000d

Figure 7: Sink and spy registers manually read using online software (serendip), the latency of the fibres is clearly visible.

References

- [1] ATLAS Collaboration. Technical Design Report for the Phase-I Upgrade of the ATLAS TDAQ System. Technical Report CERN-LHCC-2013-018. ATLAS-TDR-023, Sep 2013. Final version presented to December 2013 LHCC.
- [2] N. A. Gorasia. private communication.